

ENGINEERING
TOMORROW

Danfoss

Technical Information

D1 High Power Open Circuit Pumps

Size 130/145/193/260

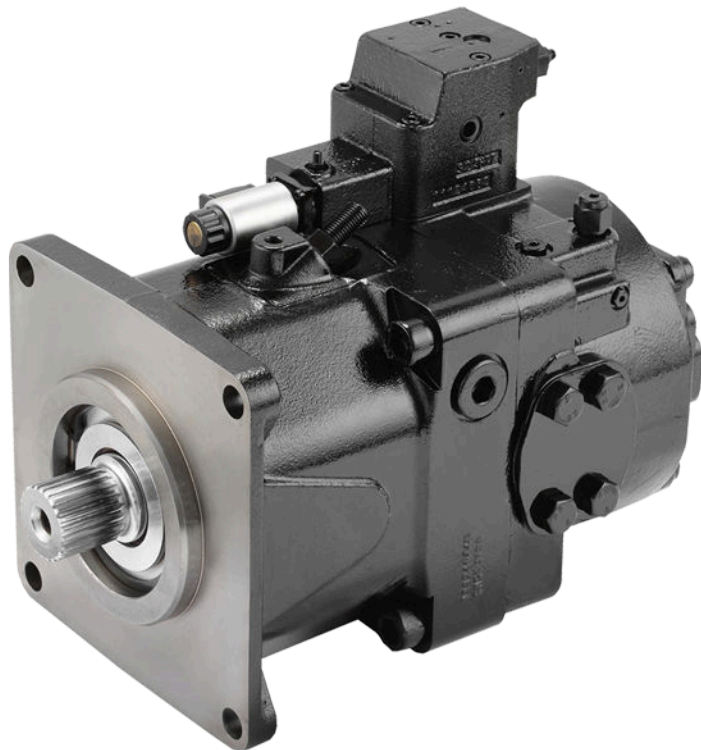

Revision history*Table of revisions*

Date	Changed	Rev
June 2020	Changed document number from 'BC00000243' and 'L1426007' to 'BC157786485289' and corrected shaft descriptions	0304
June 2019	Updated Model Code chapter	0202
December 2018	Updated shaft torque specifications	0201
November 2018	Added shaft option K	0113
October 2018	Minor Update	0112
August 2018	Minor Update (Model Code)	0111
July 2018	Minor Update	0110
July 2018	Added NPNR Control	0109
June 2018	Major Update	0108
May 2018	Added units and drawing	0107
January 2017	Added Size 130	0106
September 2016	some update of drawing and numbers	0105
May 2016	Added Size 260	0104
March 2016	minor update	0103
February 2016	minor update	0102
January 2016	Converted to Danfoss layout - DITA CMS	0101
July 2015	Updated drawings	AC
April 2015	Added 145 cc information	AB
May 2014	First edition	AA

Contents

General Information

Overview.....	5
Features and benefits.....	5
Typical applications.....	5
Design.....	6

Technical Specifications

D1 130-260 pump specifications.....	8
Fluid specifications.....	9

Model Code

Model code.....	10
D1P 130-260 displacement, rotation and product version.....	11
D1P 130-260 control types.....	11
D1P 130-260 input shaft options.....	12
D1P 130-260 mounting flange options.....	12
D1P 130-260 end cap and main port options.....	12
D1P 130-260 auxiliary mounting flange options.....	12
D1P 130-260 power control settings.....	13
D1P 130-260 pressure compensated control setting.....	13
D1P 130-260 load sensing control settings.....	14
D1P 130-260 hydraulic displacement control setting.....	14
D1P 130-260 maximum displacement settings.....	14
D1P 130-260 minimum displacement settings.....	14
D1P 130-260 special hardware and special features.....	14
Tandem pump information.....	16

Parameters

Pressure.....	17
Speed.....	17
Performance.....	18
Input power.....	18
Output flow.....	20
Efficiency.....	21
Fluid.....	22
Viscosity.....	22
Temperature.....	22
Fluid velocity.....	22
Shaft torque ratings.....	23
Shaft load.....	23
Mounting flange loads.....	23
Auxiliary mounting pads.....	23
Estimating overhung load moments.....	24
Understanding and minimizing system noise.....	25
Installation.....	25
Filtration.....	25
Reservoir.....	26
Sizing Equations.....	26

Control Type

NPNN (Pressure Compensated Control).....	27
NPSN (Pressure Compensated Control + Load Sensing Control).....	29
NPNR (Pressure Compensated Control + Remote Pressure Compensated Control).....	31
TPSN (Power Control + Pressure Compensated Control + Load Sensing Control).....	33
NNES (Electric Displacement Control + Load Sensing Control).....	35
Solenoid Specification.....	37
Standard EDC Valve.....	38
NNES Priority.....	38
TPE2/TPE5 (Power Control + Pressure Compensated Control + Electric Displacement Control).....	39
TPE2/TPE5 Priority.....	39
NPE2/NPE0 (Pressure Compensated Control + Electric Displacement Control).....	40

Contents

Installation Drawings

Size 130/145.....	41
Dimensions (mm) and port descriptions.....	41
Size 130/145: TPSN w/o Charge Pump.....	41
Size 130/145: TPE5 w/o Charge Pump.....	43
Size 130/145: TPSN w/ Charge pump	45
Size 130/145: TPE5 w/ Charge Pump.....	47
Input shaft.....	49
Shaft specifications.....	49
Aux mounting flange.....	51
Size 130/145: Option NN (No Coupling).....	51
Size 130/145: Option A1 (SAE-A, 9 teeth).....	51
Size 130/145: Option B1 (SAE-B, 13 teeth).....	52
Size 130/145: Option C5 (SAE-C, 14 teeth).....	52
Size 130/145: Option D5 (SAE-D, 24 teeth).....	53
Size 193.....	54
Dimensions (mm) and port descriptions.....	54
Size 193: TPE2 w/ Charge Pump.....	54
Size 193: TPSN w/ Charge Pump.....	56
Input shaft.....	58
Shaft specifications.....	58
Aux mounting flange.....	61
Size 193: Option NN (No Coupling).....	61
Size 193: Option A1 (SAE-A, 9 teeth).....	61
Size 193: Option A3 (SAE-A, 13 teeth).....	62
Size 193: Option B1 (SAE-B, 13 teeth).....	62
Size 193: Option C5 (SAE-C, 14 teeth).....	63
Size 193: Option C9 (SAE-C, 13 teeth).....	63
Size 193: Option D2 (SAE-D, 13 teeth).....	64
Size 193: Option D5 (SAE-D, 24 teeth).....	64
Size 193: Option E2 (SAE-E, 24 teeth).....	65
Size 260.....	66
Dimensions (mm) and port descriptions.....	66
Size 260: TPE2 w/ Charge Pump.....	66
Size 260: TPSN w/ Charge Pump.....	68
Input shaft.....	70
Shaft specifications.....	70
Aux mounting flange.....	73
Size 260: Option A1 (SAE-A, 9 teeth).....	73
Size 260: Option A3 (SAE-A, 13 teeth).....	73
Size 260: Option B1 (SAE-B, 13 teeth).....	74
Size 260: Option C5 (SAE-C, 14 teeth).....	74
Size 260: Option C9 (SAE-C, 13 teeth).....	75
Size 260: Option D2 (SAE-D, 13 teeth).....	75
Size 260: Option D5 (SAE-D, 24 teeth).....	76
Size 260: Option E2 (SAE-E, 24 teeth).....	76
Size 260: Option E3 (SAE-E, 28 teeth).....	77

Additional Information

Tandem with Danfoss pumps.....	78
Tandem pump torque.....	78
Tightening torque.....	79

Installation Notes

Below reservoir (standard).....	80
Above reservoir.....	81
Reservoir installation.....	82

Displacement Limiter

Displacement limiter setting.....	83
-----------------------------------	----

General Information

D1P overview

The D1 pump series are high performance variable axial piston pumps designed primarily for open circuit hydraulic systems used in heavy duty mobile applications.

Displacement options

- 130 cm³ [7.93 in³]
- 145 cm³ [8.85 in³]
- 193 cm³ [11.78 in³]
- 260 cm³ [15.87 in³]

Product highlights

- Maximum working pressure: 350 bar [5076 psi], peak pressure (intermittent): 400 bar [5802 psi].
- Input speed up to 2,500 rpm.

Control options

- Mechanical power control
- Electric power control
- Pressure compensated control
- Remote pressure compensated control
- Electric proportional displacement control
- Load sensing control

D1P features and benefits

- Robust design for harsh conditions.
- Swashplate, servo-controlled design, with proven reliability and performance.
- Angled piston bore design improves self-priming capability.
- The spherical valve plate and cylinder block interface provide stable cylinder block rotation, thus achieving high efficiency.
- Integral charge pump option allows the pump to run at higher speed and achieve good cold start performance.
- Full through-drive capability is suitable for adding axial piston pumps and gear pumps.
- Optimized cradle bearing improves pump service life.
- PLUS+1[®] compliant controls.
- Can be used together in combination with other Danfoss Power Solutions products in the overall hydraulic system, such as:
 - Pumps (S45, S90, H1P, gear pumps, etc.)
 - PVG valves
 - Motors (S90, H1B, etc).

D1P typical applications

- Concrete Machinery
- Mining Machinery
- Drilling Machinery
- Material Handling
- Marine and Off-shore Machinery
- Oil Machinery

General Information

- Excavators
- Wheel Loaders
- Industrial Hydraulics

Design

D1P sectional view

The cross sectional view of the D1P can be used to identify individual parts of the product.

Series D1 pump (w/charge pump) cross-section view

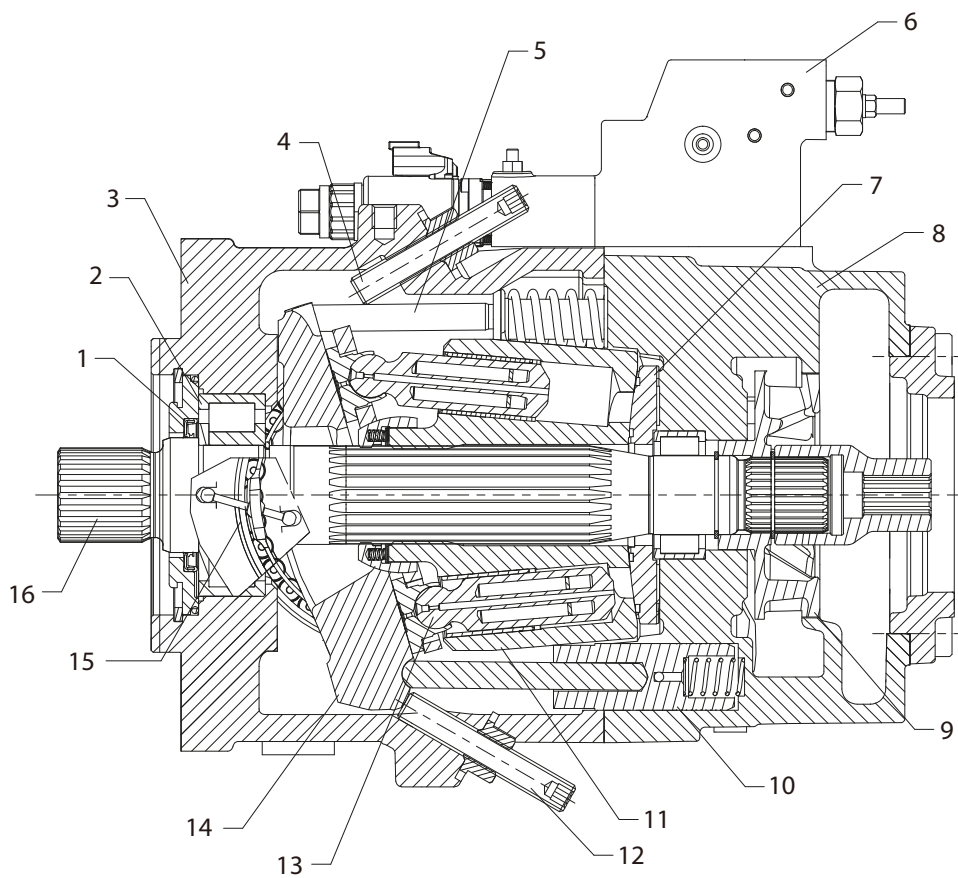

- | | | |
|--|---------------------------|---|
| 1. Shaft Seal | 2. Roller Bearing | 3. Housing |
| 4. Minimum Displacement Limiter | 5. Bias Piston | 6. Control (TPE5/TPE2) |
| 7. Valve Plate | 8. End cap | 9. Charge Pump |
| 10. Servo Piston | 11. Cylinder Block | 12. Maximum Displacement Limiter |
| 13. Piston | 14. Swashplate | 15. Swashplate Bearing |
| 16. Input Shaft | | |

Some internal parts may be different depending on frame size and options desired.

General Information

D1P schematic with charge pump

Basic schematic without control/with charge pump

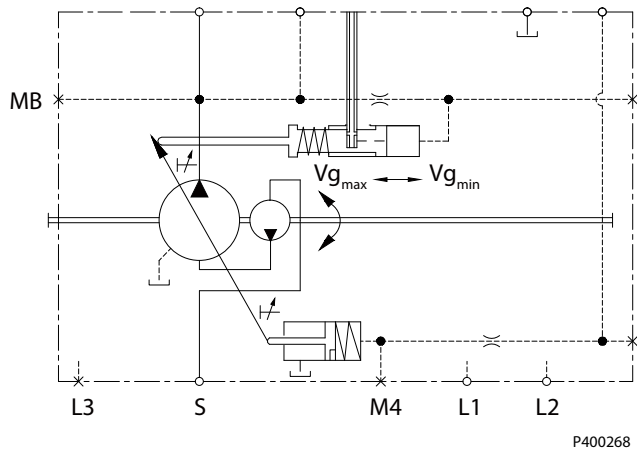

The charge pump (see schematic) is a circulating pump with which the pump is charged and therefore can be operated at higher speeds. This also improves cold starting at low temperatures and high viscosity of the hydraulic fluid. The pressurized reservoir is therefore unnecessary in most cases. A reservoir pressure of a max. 2 bar is permissible with charge pump.

Technical Specifications
D1 130-260 pump specifications
(Theoretical values, without efficiency and tolerances; value rounded)

Features		Unit	130		145		193	260
			W/O Charge Pump	W/ Charge Pump	W/O Charge Pump	W/ Charge Pump	W/Charge Pump	W/Charge Pump
Displacement	Maximum	cm ³ [in ³]	130 [7.93]	130 [7.93]	145 [8.85]	145 [8.85]	193 [11.78]	260 [15.87]
	Minimum		0	0	0	0	0	0
Available Rotation		CCW [L]	●	●	●	●	●	●
		CW [R]	●	●	●	●	●	●
Input Speed	Min.	rpm	500	500	500	500	500	500
	Rated at max. displacement (Vg max.)		2200 ¹	2500 ²	2200 ²	2500 ³	2500 ³	2300 ³
	Maximum at Vg < Vg max. ³		2500	2500	2200	2500	2500	2300
Flow at max. speed & displacement (n max. & Vg max.)		l/min [US gal/min]	286 [76]	325 [86]	319 [84]	363 [96]	483 [128]	598 [158]
System (Working) Pressure ⁴	Max. Working Pressure	bar [psi]	350 [5076]					
	Max. Pressure		400 [5802]					
Inlet Pressure (Absolute)	Minimum	bar [psi]	0.8 [11.6]	0.6 [8.7]	0.8 [11.6]	0.6 [8.7]	0.6 [8.7]	0.6 [8.7]
	Maximum		30 [435] ⁵	2 [29]	30 [435]	2 [29]	2 [29]	2 [29]
Case Pressure (Absolute)	Maximum above inlet	bar [psi]	1.2 [17.4]					
	Maximum		2 [29]					
Filling Capacity		L [US gal]	2.9 [0.77]		2.9 [0.77]		3.8 [1]	4.6 [1.3]
Torque at Vg max. & Δp = 350 bar		N·m [lbf·in]	724 [6408]		808 [7151]		1075 [9515]	1448 [12816]
Power at Q max. (max. flow) & Δp = 350 bar		kW [hp]	159 [213]	190 [255]	186 [249]	211 [283]	281 [377]	349 [468]
Mass Moment of Inertia of internal rotating components		kg·m ² [slug·ft ²]	0.0299 [0.0221]	0.0306 [0.0226]	0.0299 [0.0221]	0.0306 [0.0226]	0.0576 [0.0426]	0.2080 [0.1537]
Mass		kg [lb]	68 [150]	74 [163]	68 [150]	74 [163]	106 [234]	141 [311]
External Shaft Loads	External Moment M _e	N·m [lbf·in]	476 [4213]		476 [4213]		822 [7275]	1081 [9568]
Mounting Flange Load Moments	Vibratory (continuous)	N·m [lbf·in]	4553 [40297]		4553 [40297]		6286 [55636]	8477 [75027]
	Shock (maximum)		8692 [76930]		8692 [76930]		13782 [121980]	16338 [144603]

¹ The values apply at absolute pressure (Pabs) of at least 0.8 bar [11.6psi] at the suction port S and mineral hydraulic fluid.

² The values apply at absolute pressure (Pabs) of at least 0.6 bar [8.7psi] at the suction port S and mineral hydraulic fluid.

³ The values apply at Vg ≤ Vg max or in case of an increase in the inlet pressure (Pabs) at the suction port S. Please refer to *Inlet Pressure vs Speed Graph* at [D1P speed overview](#) on page 17

⁴ Applied pressures above maximum working pressure requires Danfoss application approval. Maximum (peak) pressure is the highest intermittent (t<1s) outlet pressure allowed.

⁵ If the application requires the higher inlet pressure than 5 bar [72.5psi] (up to 30 bar [435psi]), please contact.Danfoss Power Solutions.

[Counterclockwise \(CCW\) & Clockwise \(CW\) directions as viewed from the shaft end of the pump.](#)

Exceeding the permissible values could cause a loss of function, reduced life or the destruction of the pump.

Do not exceed the values shown in the table above.

Technical Specifications
D1P fluid specifications

Features		Units	Value
Viscosity	Intermittent ¹⁾	mm ² /sec [SUS]	5 [42]
	Minimum		7 [49]
	Recommended range		16 - 36 [81 - 168]
	Maximum (cold start) ²⁾		1600 [xxxxx]
Temperature range	Minimum (cold start) ²⁾	°C [°F]	-40 [-40 °F]
	Maximum intermittent ¹⁾		115 [239 °F] ³⁾
Filtration (minimum) Cleanliness per ISO 4406	Temperature Range: -40 - 90 °C [-40 - 194°F]		20/18/15
	Temperature Range: 90 - 115 °C [194 - 239°F]		19/17/14

¹⁾ Intermittent = Short term $t < 3\text{min}$ per incident.

²⁾ Cold start = Short term $t < 3\text{min}$, $p \leq 30\text{ bar}$ [435 psi], $n \leq 1000\text{ min}^{-1}$ (rpm), please contact Danfoss Power Solutions especially when the temperature is below -25 °C [-13 °F].

³⁾ Must not be exceeded locally either (e.g. in the bearing area). The temperature in the bearing area is (depending on pressure and speed) up to 5 °C [41 °F] higher than the average case drain temperature.

Model Code

D1P model code

The below illustration and the following sections describe how to identify parts of the model code and availability of certain part options based on frame size.

Example model code; D1P 260 shown

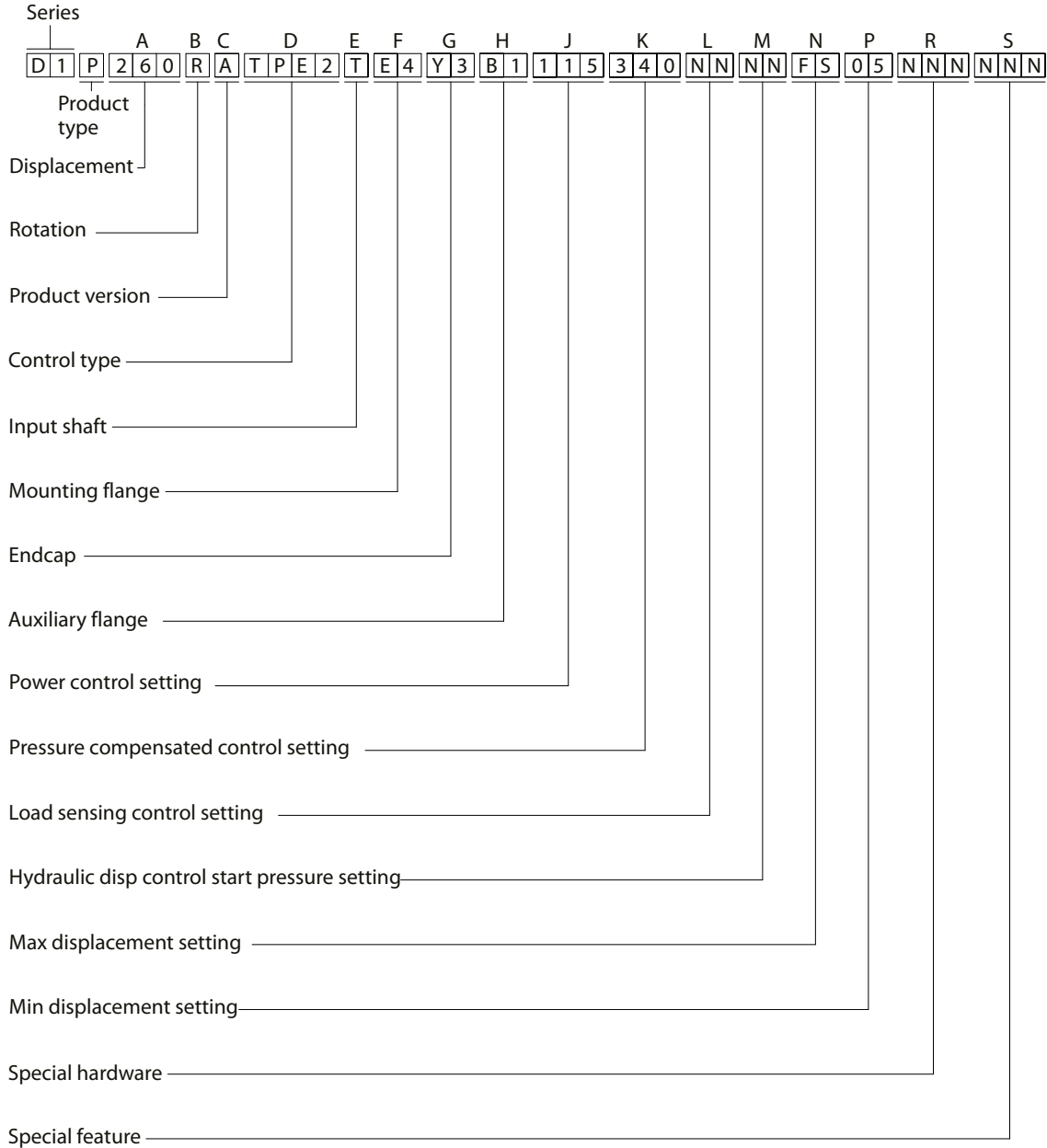

Model Code
D1P 130-260 displacement, rotation and product version
Displacement

Code	Description	130	145	193	260
130	130 cm ³ [7.93 in ³] max. displacement per revolution	●			
145	145 cm ³ [8.85 in ³] max. displacement per revolution		●		
193	193 cm ³ [11.78 in ³] max. displacement per revolution			●	
260	260 cm ³ [15.87 in ³] max. displacement per revolution				●

Rotation

Code	Description	130	145	193	260
R	Clockwise [CW]	●	●	●	●
L	Counter Clockwise [CCW]	●	●	●	●

Product Version

Code	Description	130	145	193	260
A		●	●	●	●

D1P 130-260 control types

Code	Description	130	145	193	260
NPNN	Pressure Compensated Control	●	●	●	●
NPSN	Pressure Compensated Control + Load Sensing Control	●	●	●	●
NPNR	Pressure Compensated Control + Remote Pressure Compensated Control	●	●	●	●
TPSN	Power Control + Pressure Compensated Control + Load Sensing Control	●	●	●	●
NNES	Positive Electric Displacement Control (24V DEUTSCH, 2-pin) w/Manual Override + Load Sensing Control	●	●	●	●
TPE2	Power Control + Pressure Compensated Control + Positive Electric Displacement Control (24V DEUTSCH, 2-pin) w/Manual Override			●	●
TPE5	Power Control + Pressure Compensated Control + Positive Electric Displacement Control (24V DEUTSCH, 2-pin) w/Manual Override (The control outline and size is the same as the 193/260 TPE2 control)	●	●		
NPE2	Pressure Compensated Control + Positive Electric Displacement Control (24V DEUTSCH, 2-pin) w/Manual Override			●	●
NPE0	Pressure Compensated Control + Positive Electric Displacement Control (24V DEUTSCH, 2-pin) w/Manual Override w/o Shuttle valve			●	●

Control Code Explanation:

- First digit: Power control (Torque control) , "N" means no power control.
- Second digit: Pressure compensated control, "N" means no pressure compensated control.
- Third & Fourth digits: Proportional displacement control or Load sensing control , "NN" means no control in either category.

Model Code
D1P 130-260 input shaft options

Code	Description	130	145	193	260
T	130/145/193: Spline, DIN 5480 W50 x 2 x 30 x 24 x 9g; 260: Spline, DIN 5480 W60 x 2 x 30 x 28 x 9g; Shaft Seal Material: FKM	●	●	●	●
S	Spline, SAE J744 1 3/4in, 13T 8/16 DP; Shaft Seal Material: FKM	●	●	●	●
A	193: Spline, SAE J744 2in, 15T 8/16 DP; 260: Spline, SAE J744 2 1/4in, 17T 8/16 DP; Shaft Seal Material: FKM			●	●
P	Straight Keyed DIN 6885, 130/145: AS14 x 9 x 80 193: AS16 x 10 x 100 260: AS18 x 11 x 100 Shaft Seal Material: FKM	●	●	●	●
K*	SAE J744 (D/E) 3in straight keyed shaft 0.4375x3.000in	●	●	●	●

* There is no impeller option for sizes 130 and 145 with this shaft.

D1P 130-260 mounting flange options

Code	Description	130	145	193	260
D4	SAE J744 152-4 (D)	●	●		
E4	SAE J744 165-4 (E)			●	●

D1P 130-260 end cap and main port options
End cap and main ports

Code	Description	Rotation	130	145	193	260
N1	Radial, side, flange ports Inlet: 3in port, M16 x 2; Outlet: 1in port, M12 x 1.75 SAE J518 without charge pump	CW [R] CCW [L]	●	●		
Y1	Radial, side, flange ports Inlet: 3in port, M16 x 2; Outlet: 1 1/4in port, M14 x 2 SAE J518 with charge pump	CW [R] CCW [L]	●	●		
Y2	Radial, side, flange ports Inlet: 3 1/2in port, M16 x 2; Outlet: 1 1/2in port, M16 x 2 SAE J518 with charge pump	CW [R] CCW [L]			●	
Y3	Radial, side, flange ports Inlet: 4in port, M16 x 2; Outlet: 1 1/2in port, M16 x 2 SAE J518 with charge pump	CW [R] CCW [L]				●

D1P 130-260 auxiliary mounting flange options
Auxiliary mounting flange (through-drive flange)

Code	Description	130	145	193	260
NN	No auxiliary flange	●	●	●	●
A1	SAE J744 82-2 (A) ; Spline coupling: 5/8in 9T 16/32DP	●	●	●	●
A3	SAE J744 82-2 (A); Spline coupling: 7/8in 13T 16/32DP			●	●
B1	SAE J744 101-2 (B) ; Spline coupling: 7/8in 13T 16/32DP	●	●	●	●

Model Code

Auxiliary mounting flange (through-drive flange) (continued)

Code	Description	130	145	193	260
C5	SAE J744 127-2&4 (C) ; Spline coupling:1 1/4in 14T 12/24DP	●	●	●	●
C9	SAE J744 127-2&4 (C); Spline coupling: 1 3/4in 13T 8/16DP			●	●
D2	SAE J744 152-4 (D); Spline coupling: 1 3/4in 13T 8/16DP	●	●	●	●
D5	SAE J744 152-4 (D) ; Spline coupling: N50x2x30x24x9H	●	●	●	●
E2	SAE J744 165-4 (E) ; Spline coupling: N50 x 2 x 30 x 24 x 9H			●	●
E3	SAE J744 165-4 (E) ; Spline coupling: N60 x 2 x 30 x 28 x 9H				●

D1P 130-260 power control settings

Power control setting at 1500rpm (kW), "3 digit code"

Code ¹	Description	130	145	193	260
NNN	No Power Control	●	●	●	●
XXX	xxx kW between ranges specified below (For example: Code "090" means 90kW) at 1500 rpm				
035-090	35-90 kW [47-121 hp] at 1500 rpm ²	●	●		
050-120	50-120 kW [67-161 hp] at 1500 rpm ²			●	
070-140	70-140 kW [94-188 hp] at 1500 rpm ²				●

¹ For settings out of these ranges, please contact Danfoss Power Solutions. Range allowed for NPNR (Pressure compensated + Remote Pressure compensated control) is 15-35 bar

² Only increments of 5kW [6.7 hp] are allowed. E.g. 035, 040, 045, etc.)

[If the speed is not 1500rpm, please make a conversion using the following formula, assuming constant torque:](#)

$$P_{\text{setting@1500 rpm}} = P_{\text{actual}} * \frac{1500}{n_{\text{actual}}}$$

For example:

If actual power is 110 kW at 2100 rpm, the conversion to obtain the power control setting at 1500 rpm should be $110 * 1500 / 2100 = 79$, choose 080 option (round to closest 5 kW increment option).

D1P 130-260 pressure compensated control setting

Pressure compensated control setting (bar), "3 digit code"

Code*	Description	130	145	193	260
NNN	No Pressure compensated control	●	●	●	●
XXX	xxx bar between the range specified below (For example: Code "320" means 320 bar [4641 psi])				
150~350	150~350 bar [2176~5076 psi] (Please select pressure compensated control setting in increments of 10 bar [145 psi]. E.g. 150 or 160 or 170, etc.)	●	●	●	●

* For settings out of these ranges, please contact Danfoss Power Solutions. Range allowed for NPNR (Pressure compensated + Remote Pressure compensated control) is 15-35 bar

Model Code
D1P 130-260 load sensing control settings
L - Load Sensing Control Setting (bar), "2 digit code"

Code	Description	130	145	193	260
NN	No load sensing control	●	●	●	●
XX	xx bar between the range specified below (For example: Code "25" means 25 bar [363 psi])				
10~35*	10~35 bar [145~508 psi] (Please select load sensing control setting in increments of 1 bar [14.5 psi]. E.g. 10 or 11 or 12, etc.)	●	●	●	●

* For settings out of these ranges, please contact Danfoss Power Solutions. Range allowed for NPNR (Pressure compensated + Remote Pressure compensated control) is 15-35 bar

D1P 130-260 hydraulic displacement control setting
Hydraulic displacement control start pressure setting, "2 digit code"

Code	Description	130	145	193	260
NN	No hydraulic displacement control	●	●	●	●
04-10	4-10 bar			●	●

D1P 130-260 maximum displacement settings
Maximum displacement setting, "2 digit code"

Code	Description	130	145	193	260
FS	Factory setting : 100%	●	●	●	●
XX*	XX% of maximum displacement (For example: Code "90" means 90% of maximum displacement)	●	●	●	●

* Please consider frame sizing and the [Displacement Limiter](#) increments when selecting a maximum displacement setting.

D1P 130-260 minimum displacement settings
Minimum displacement setting, "2 digit code"

Code	Description	130	145	193	260
FS	0% of maximum displacement limit setting	●	●	●	●
XX	XX% of maximum displacement limit setting	●	●	●	●

[If a different minimum displacement setting is required, please contact Danfoss Power Solutions.](#)

D1P 130-260 special hardware and special features
Special hardware

Code	Description	130	145	193	260
NNN	None	●	●	●	●

Model Code

Special features

Code	Description	130	145	193	260
NNN	Factory Setting (Paint-black, tag, Danfoss, format A)	●	●	●	●
NXN	Factory Setting (No paint, tag, Danfoss, format A, w/o filter)	●	●	●	●
NNF	Factory Setting (Paint-black, tag , Danfoss, format A) with control oil filter				●

Model Code

D1P tandem pump information

Information about tandem pump direction and ordering instructions are found below.

Pump direction

Auxiliary pump
INDEX = 0°

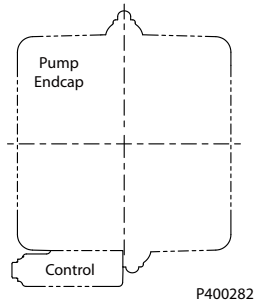

Auxiliary pump
INDEX = 90°

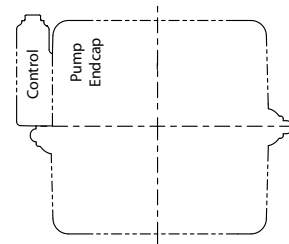

When assembling a system the first pump is always to be considered at 0° INDEX as shown below.

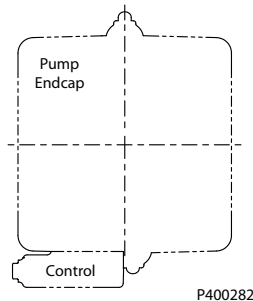

Auxiliary pump
INDEX = 270°

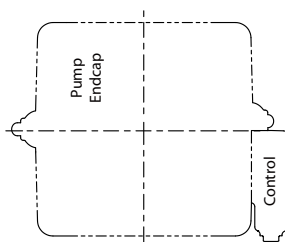

Auxiliary pump
INDEX = 180°

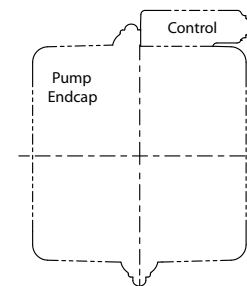

For gear pump tandem angle information, please contact Danfoss Power Solutions.

Please see Additional information for more tandem pump information.

Ordering tandem pumps

When ordering tandem pumps, the type designations of the 1st and 2nd pumps must be connected by a "+", and tandem pump angle should be given as indicated below.

Ordering example:

D1P193RATPE2TE4Y2E2090320NNNNFSFSNNNNNN +

D1P193RATPE2TE4Y2NN090320NNNNFSFSNNNNNN

Tandem angle 0° + 180°

Parameters

D1P pressure overview

- Maximum working pressure** The highest recommended outlet (application). Operating at or below this pressure should yield satisfactory product life. For all applications, the load should move below this pressure. This corresponds to the maximum allowable pressure compensated control setting.
- Maximum (peak) pressure** The highest intermittent ($t < 1s$) outlet pressure allowed. Maximum machine load should never exceed this pressure, and pressure overshoots should not exceed this pressure.
- Inlet pressure** The absolute pressure in the pump suction port, it is related to pump speed. Make sure it is in the allowable range, see [D1 pump specifications](#).
- Case pressure** The case pressure at the ports L1 and L2 may be a maximum of 1.2 bar [17.4 psi] higher than the inlet pressure at the port S but not higher than 2 bar. Size drain plumbing accordingly and connect it to tank directly. The housing must always be filled with hydraulic fluid.

D1P speed overview

- Rated speed** The fastest recommended operating speed at full displacement and at least 0.6 bar [8.7 psi] abs with charge pump (0.8 bar [11.6 psi] abs without charge pump) inlet pressure. Operating at or below this speed should yield satisfactory product life.
- Maximum speed** The highest recommended operating speed at full power conditions. Operating at or beyond maximum speed requires positive inlet pressure and/or a reduction of pump outlet flow. Refer to [Inlet pressure vs. speed](#) on page 17, chart below.

Inlet pressure vs. speed

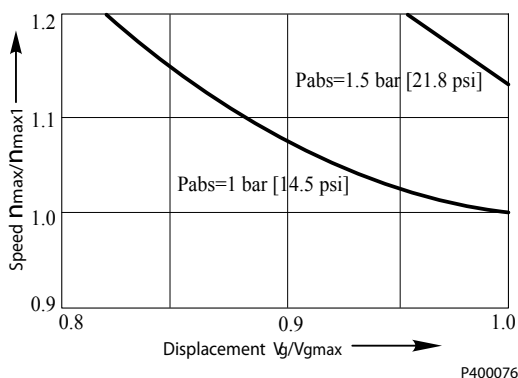

- Minimum speed** The lowest operating speed allowed. Operating below this speed will not yield satisfactory performance.

Caution! Threat to pump life!

Working outside of the pump's operating parameters may result in shortened life expectancy of the pump.

Always work within the operating conditions of the pump application.

With accurate duty cycle information, your Danfoss Power Solutions representative can assist you in calculating expected pump life.

Parameters

Performance

D1P input power

Input power requirements depend on displacement per revolution, speed, efficiency, and operating pressure.

130cc power vs input speed

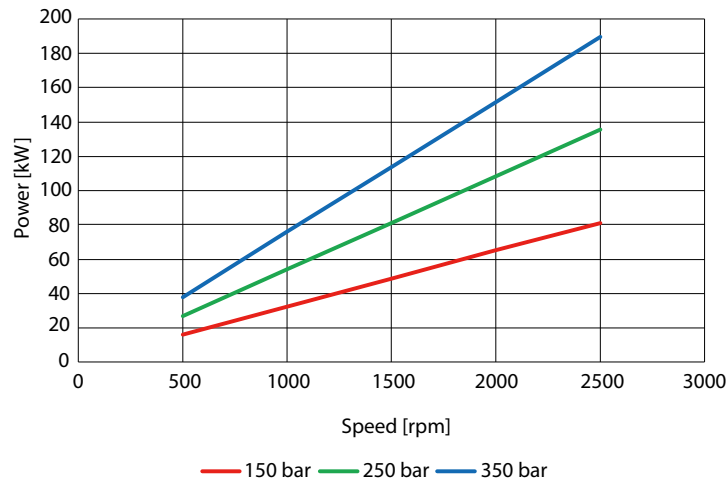

145cc power vs input speed

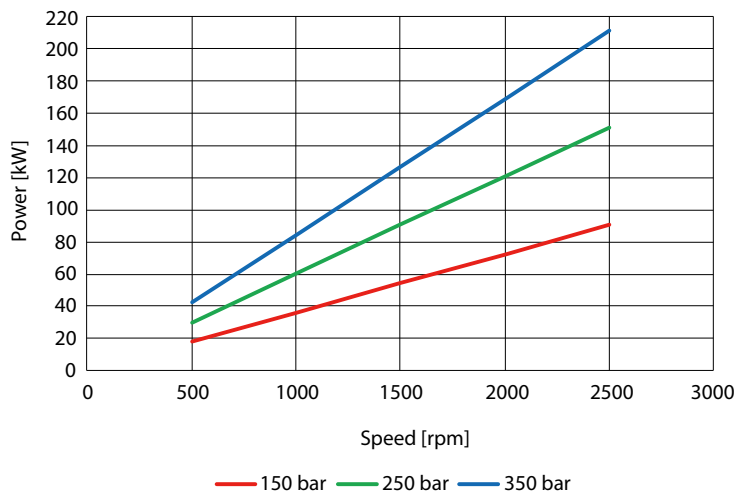

Parameters

193cc power vs input speed

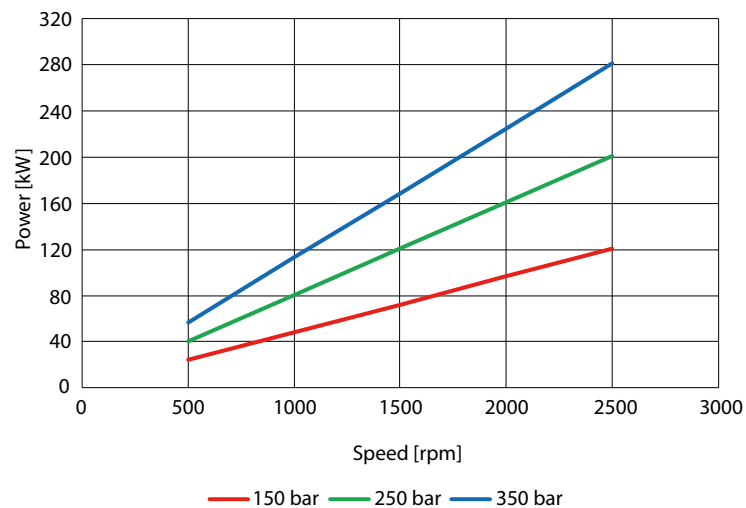

260cc power vs input speed

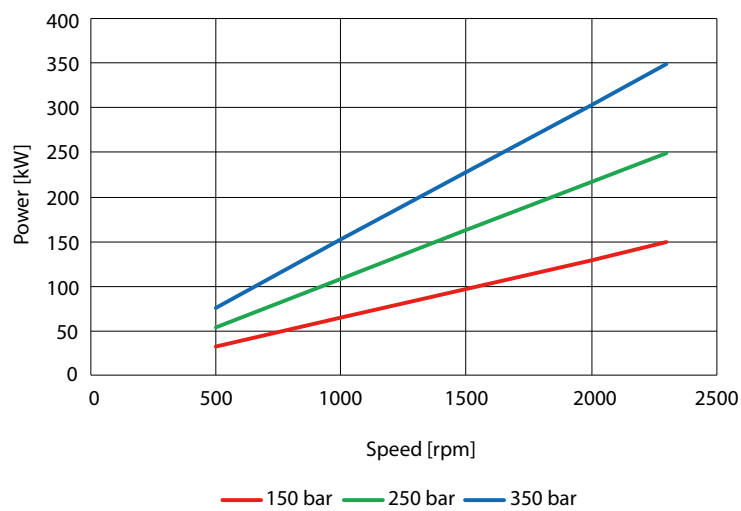

Parameters

D1P output flow

Output flow depends on displacement per revolution, speed, and efficiency.

130cc flow vs speed

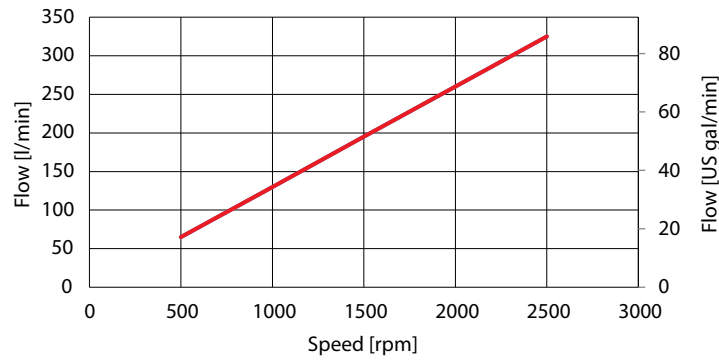

145cc flow vs speed

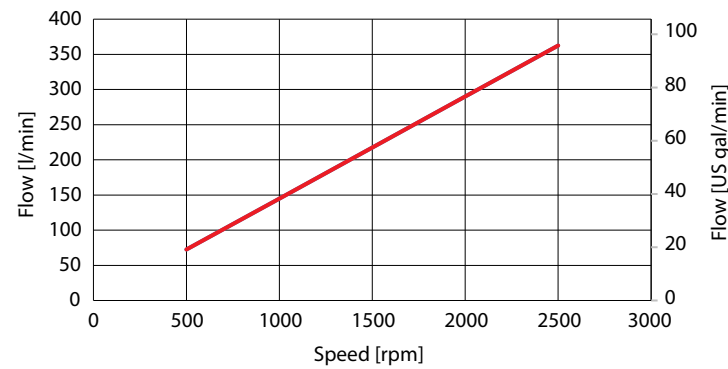

Parameters

193cc flow vs speed

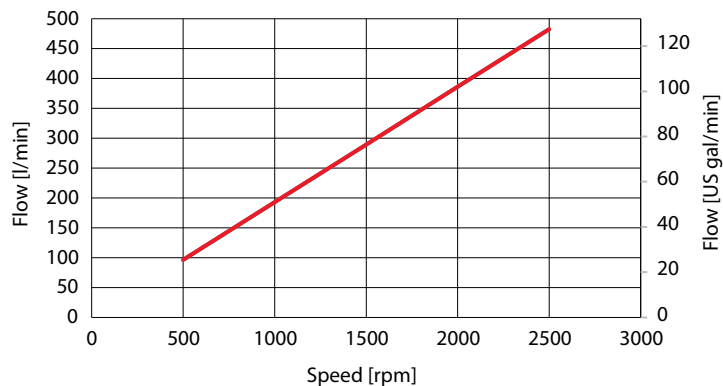

260cc flow vs speed

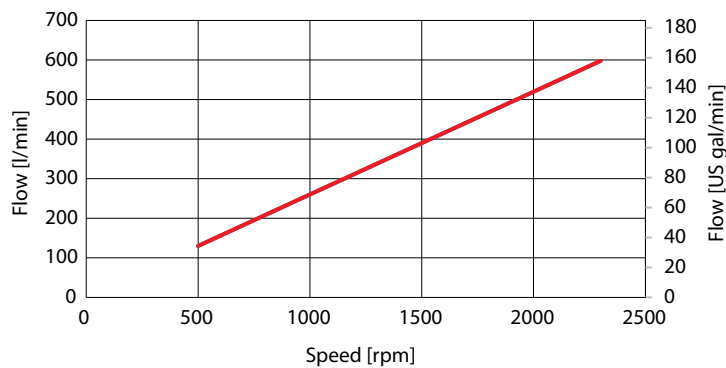

D1P efficiency overview

Efficiency data depends on various operating parameters such as: working and inlet pressure, operating temperature, displacement, and fluid viscosity. For an accurate efficiency calculation, please contact your Danfoss Power Solutions representative.

All performance data are theoretical values, without efficiency or tolerances. Data valid at full displacement and operation parameters within the recommended ranges.

Parameters

D1P fluid overview

Ratings and performance data for D1 pumps are based on operating with premium hydraulic fluids containing oxidation, rust, and foam inhibitors. These include premium turbine oils, API CD engine oils per SAE J183, M2C33F or G automatic transmission fluids (ATF), Dexron II (ATF) meeting Allison C-3 or Caterpillar T0-2 requirements, and certain specialty agricultural tractor fluids. For more information on hydraulic fluid selection, see Danfoss Power Solutions publications **BC152886484524** *Hydraulic Fluids and Lubricants*, Technical Information, and **520L0465** *Experience with Biodegradable Hydraulic Fluids*, Technical Information.

D1P viscosity

Minimum Viscosity This should only occur during brief occasions of maximum ambient temperature and severe duty cycle operation.

Maximum Viscosity This should only occur at cold start. Pump performance will be reduced. Limit speeds until the system warms up.

Maintain fluid viscosity within the recommended range for maximum efficiency and pump life.

D1P temperature overview

Minimum Temperature Relates to the physical properties of the component materials. Cold oil will not affect the durability of the pump components. However, it may affect the ability of the pump to provide flow and transmit power

Maximum Temperature Relates to material properties. Don't exceed it. Measure maximum temperature at the hottest point in the system. This is usually the case drain.

D1P fluid velocity

Choose piping sizes and configurations sufficient to maintain optimum fluid velocity, and minimize pressure drops. This reduces noise, pressure drops, overheating and maximizes system life and performance.

Recommended fluid velocities

System lines	6 to 9 m/sec
Suction line	1 to 2 m/sec
Case drain	3 to 5 m/sec

Typical guidelines; obey all pressure ratings.

Velocity equations

SI units

Q = flow (l/min)

A = area (mm²)

Velocity = (16.67·Q)/A (m/sec)

Parameters

D1P shaft torque ratings

Shaft drawings and maximum torque ratings are found in these sections:

- [Size 130/145 shaft specifications](#)
- [Size 193 shaft specifications](#)
- [Size 260 shaft specifications](#)

Maximum torque ratings are based on shaft strength with no radial force; do not exceed the torque limits.

D1P shaft load

Series D1 pump bearing is capable of accepting external radial and thrust (axial) loads. The external radial shaft load limits are a function of the load position, orientation, and the operating conditions of the pump.

The maximum allowable radial load (R_e) is based on the maximum external moment (M_e) and the distance (L) from the mounting flange to the load. Compute radial loads using the formula below. [D1 pump specifications](#) gives maximum external radial load (R_e) and thrust (axial) load (T_{in} , T_{out}) limits.

$$M_e = R_e \cdot L$$

L = Distance from mounting flange to point of load

M_e = Maximum external moment

R_e = Maximum radial side load

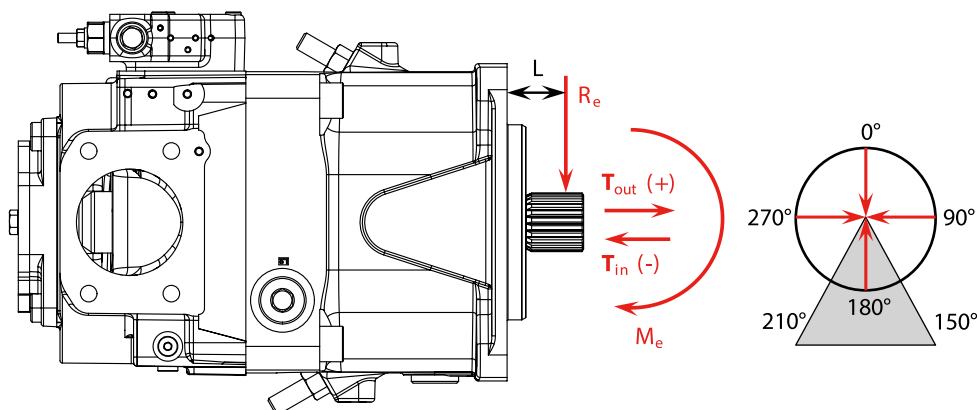

P400077

All shaft loads affect bearing life. In applications where external shaft loads cannot be avoided, maximize bearing life by orienting the load between the 150° and 210° positions, as shown.

D1P mounting flange loads

Adding auxiliary pumps and/or subjecting pumps to high shock loads may overload the pump mounting flange. [D1 pump specifications](#) gives allowable continuous and shock load moments. Applications with loads outside allowable limits require additional pump support.

- **Shock load moment (M_S)** is the result of an instantaneous jolt to the system.
- **Continuous load moments (M_C)** are generated by the typical vibratory movement of the application.

D1P auxiliary mounting pads

Auxiliary mounting pads are available. Since the auxiliary pad operates under case pressure, use an O-ring to seal the auxiliary pump mounting flange to the pad. Oil from the main pump case lubricates the drive coupling.

Parameters

Understanding and minimizing system noise

Noise is transmitted in fluid power systems in two ways: as fluid borne noise, and structure borne noise.

Fluid-borne noise (pressure ripple or pulsation) is created as pumping elements discharge oil into the pump outlet. It is affected by the compressibility of the oil, and the pump's ability to transition pumping elements from high to low pressure. Pulsations travel through the hydraulic lines at the speed of sound until there is a change (such as an elbow) in the line. Amplitude varies with overall line length and position.

Structure borne noise is transmitted wherever the pump casing connects to the rest of the system. The way system components respond to excitation depends on their size, form, material, and mounting.

[System lines and pump mounting can amplify pump noise.](#)

Follow these suggestions to help minimize noise in your application:

- Use flexible hoses.
- Limit system line length.
- If possible, optimize system line position to minimize noise.
- If you must use steel plumbing, clamp the lines.
- If you add additional support, use rubber mounts.
- Test for resonance in the operating range; if possible avoid them.

D1P installation

Series D1 pumps may be installed in any position. To optimize inlet conditions, install the pump at an elevation below the minimum reservoir fluid level. Design inlet plumbing to maintain inlet pressure within prescribed limits (see Inlet pressure limits on [D1 pump specifications](#))

Fill the pump housing and inlet line with clean fluid during installation. Connect the case drain line to the uppermost drain port (L1, L2 or L3) to keep the housing full during operation.

To allow unrestricted flow to the reservoir, use a dedicated drain line. Connect it below the minimum reservoir fluid level and as far away from the reservoir outlet as possible. Use plumbing adequate to maintain case pressure within prescribed limits (see case pressure limits on [D1 pump specifications](#)).

D1P filtration

To prevent damage to the pump, including premature wear, fluid entering the pump inlet must be free of contaminants. Series D1 pumps require system filtration capable of maintaining fluid cleanliness at class 20/18/15 according to ISO 4406-1999 or better.

Danfoss Power Solutions does not recommend suction line filtration. Suction line filtration can cause high inlet vacuum, which limits pump operating speed. Instead we recommend a 125 µm (150 mesh) screen in the reservoir covering the pump inlet. This protects the pump from coarse particle ingestion.

Return line filtration is the preferred method for open circuit systems. Consider these factors when selecting a system filter:

- Cleanliness specifications
- Contaminant ingress rates
- Flow capacity
- Desired maintenance interval

Typically, a filter with a beta ratio of $\beta_{10} = 10$ is adequate. However, because each system is unique, only a thorough testing and evaluation program can fully validate the filtration system.

For more information, see Danfoss Power Solutions publication **BC152886482150** *Design Guidelines for Hydraulic Fluid Cleanliness*.

Parameters

Reservoir

The reservoir provides clean fluid, dissipates heat, and removes entrained air from the hydraulic fluid. It allows for fluid volume changes associated with fluid expansion and cylinder differential volumes. Minimum reservoir capacity depends on the volume needed to perform these functions. Typically, a capacity of one to three times the pump flow (per minute) is satisfactory.

Locate the reservoir outlet (suction line) near the bottom, allowing clearance for settling foreign particles. Place the reservoir inlet (return lines) below the lowest expected fluid level, as far away from the outlet as possible.

Sizing Equations

Use these equations to help choose the right pump size and displacement for your application.

Based on SI units

Flow Output flow $Q = \frac{V_g \cdot n \cdot \eta_v}{1000}$ (l/min)

Torque Input torque $M = \frac{V_g \cdot \Delta p}{20 \cdot \pi \cdot \eta_m}$ (N·m)

Power Input power $P = \frac{M \cdot n \cdot \pi}{30\,000} = \frac{Q \cdot \Delta p}{600 \cdot \eta_t}$ (kW)

Based on US units

Output flow $Q = \frac{V_g \cdot n \cdot \eta_v}{231}$ (US gal/min)

Input torque $M = \frac{V_g \cdot \Delta p}{2 \cdot \pi \cdot \eta_m}$ (lbf·in)

Input power $P = \frac{M \cdot n \cdot \pi}{198\,000} = \frac{Q \cdot \Delta p}{1714 \cdot \eta_t}$ (hp)

Variables

SI units [US units]

V_g = Displacement per revolution cm³/rev [in³/rev]

P_o = Outlet pressure bar [psi]

P_i = Inlet pressure bar [psi]

Δp = $p_o - p_i$ (system pressure) bar [psi]

n = Speed min⁻¹ (rpm)

η_v = Volumetric efficiency

η_m = Mechanical efficiency

η_t = Overall efficiency ($\eta_v \cdot \eta_m$)

Control Type

NPNN (Pressure Compensated Control)

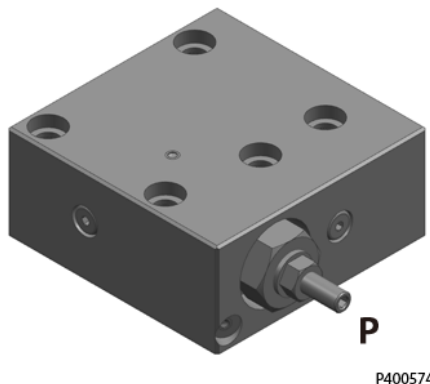

D1P 130/145/193/260+NPNN

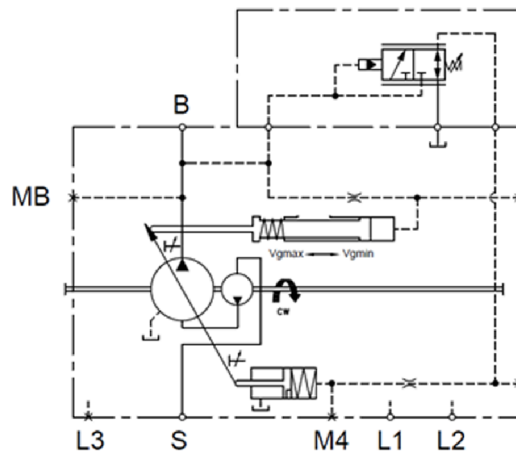

P400575

Pressure Compensated Control (P) Principle

The P control design maintains a constant pressure in the hydraulic circuit as flow varies. The P control modulates pump flow accordingly to maintain system pressure at the P setting as the P adjusting screw and spring defines.

Pressure Compensated Control (P) Operation

When system pressure, acting on the non-spring end of the P spool, overcomes the force of the P spring, the spool shifts porting system pressure to the servo piston and the swashplate angle decreases. When system pressure drops below the P setting, the P spring shifts the spool in the opposite direction connecting the servo piston to pump case and the swashplate angle increases. The swashplate is maintained at whatever angle is required to keep system pressure at the P setting.

P characteristic

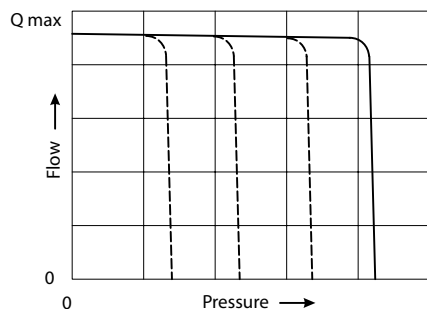

It is recommended that a relief valve be installed in the pump outlet for additional system protection.

Control Type**Response/Recovery**

Pressure Compensated (PC) Control Response/Recovery Times* @80°C, 350 bar, 1500rpm		
Frame Size	Response (msec)	Recovery (msec)
130cc	150	270
145cc	150	270
193cc ¹	280	500
260cc	154	327

¹ Tested at 1800rpm

Values may vary depending on application conditions. For more information, please contact Danfoss Power Solutions.

Control Type

NPSN (Pressure Compensated Control + Load Sensing Control)

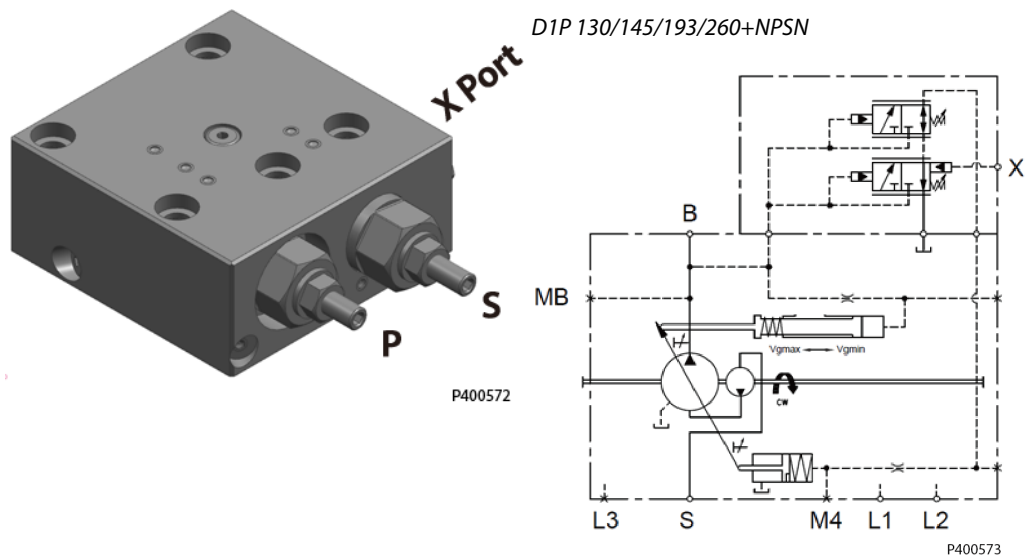

Pressure Compensated Control (P) Principle and Operation

Please refer to [NPNN \(Pressure Compensated Control\)](#) on page 27

Load Sensing Control (S) Principle

The S control design matches pump flow with system demand. The S control senses the flow demand of the system as a pressure drop across the external control valve (1).

As (1) opens and closes, the pressure difference (delta) across the valve changes. When opening, the delta decreases. When closing, the delta increases. The S control then increases or decreases pump flow to the system until the pressure delta becomes equal to the S setting as defined by the S adjusting screw and spring.

Load Sensing Control (S) Operation

Through internal porting, system pressure [upstream of (1)] is applied to the non-spring end of the S spool, and through hydraulic line connected at port X, load pressure [downstream of (1)] is applied to the spring end. This arrangement allows the S spool to act on the delta between system pressure and load pressure. The S spring sets the threshold of operation (S setting).

Because the swashplate is biased to maximum angle, the pump attempts to deliver full flow to the hydraulic system. When the flow being delivered exceeds demand, the pressure delta across the (1) is great enough to overcome spring force and shift the S spool porting system pressure to the servo piston. The pump de-strokes reducing flow until the delta across the (1) becomes equal to the S setting.

When flow being delivered is less than demand, the delta across the (1) drops below the S setting and the S spring shifts the spool connecting the servo piston to pump case. The pump strokes increasing flow until the delta across the (1) becomes equal to the S setting.

When the external control valve (1) is placed in neutral, it connects the LS signal line to drain. With no LS pressure acting on the non-spring end of the LS spool, the pump adjusts stroke to whatever position necessary to maintain system pressure at the LS setting. The pump is now in low pressure standby mode.

(1) is not in the scope of supply.

Control Type

S characteristic

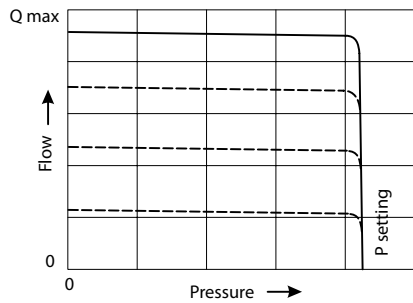

For additional system protection, install a relief valve in the pump outlet line.

NPSN Priority

The Pressure Compensated Control (P) has priority over the Load Sensing Control (S).

Response/Recovery

Load Sensing (LS) Response/Recovery Times @80°C, 1500rpm, LS Setting at 25 bar		
Frame Size	Response (msec)	Recovery (msec)
130cc	260	360
145cc	260	360
193cc ¹	233	264
260cc	309	327

¹ Tested with a LS setting of 20bar

Values may vary depending on application conditions. For more information, please contact Danfoss Power Solutions

Control Type

NPNR (Pressure Compensated Control + Remote Pressure Compensated Control)

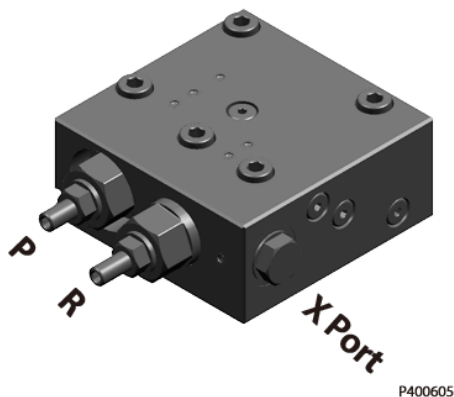

D1P 130/145/193/260+NPNR

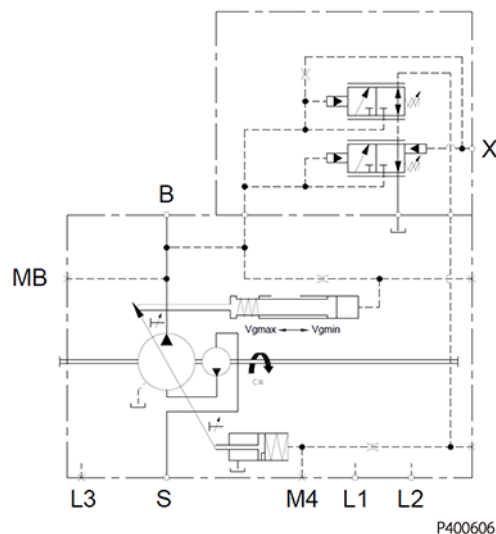

Pressure Compensated Control (P) Principle and Operation

Please refer to [NPN \(Pressure Compensated Control\)](#) on page 27.

Remote Pressure Compensated Control (R) Principle

The remote PC control is a two-stage control that allows multiple PC settings. Remote PC controls are commonly used in applications requiring low and high pressure PC operation.

For this control, Danfoss recommends a load sense setting of 20bar.

Remote Pressure Compensated Control (R) Operation

The remote PC control uses a pilot line connected to an external hydraulic valve. The external valve changes pressure in the pilot line, causing the PC control to operate at a lower pressure. When the pilot line is vented to reservoir, the pump maintains pressure at the load sense setting. When pilot flow is blocked, the pump maintains pressure at the PC setting. An on-off solenoid valve can be used in the pilot line to create a low-pressure standby mode. A proportional solenoid valve, coupled with a microprocessor control, can produce an infinite range of operating pressures between the low pressure standby setting and the PC setting.

R characteristic

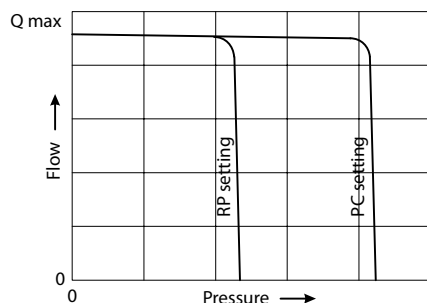

For additional system protection, install a relief valve in the pump outlet line.

Control Type**NPNR Priority**

When the pump's X-port is vented to tank, or limited to some pressure setting via a remote valve, the remote pressure compensator function will control the maximum outlet pressure of the pump. If the pump's outlet pressure reaches the pressure setting of the pressure compensator (PC) function, the PC function will take priority and limit the pump's maximum pressure.

Control Type

TPSN (Power Control + Pressure Compensated Control + Load Sensing Control)

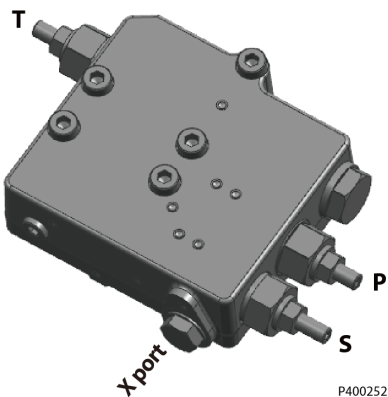

D1P 130/145+TPSN

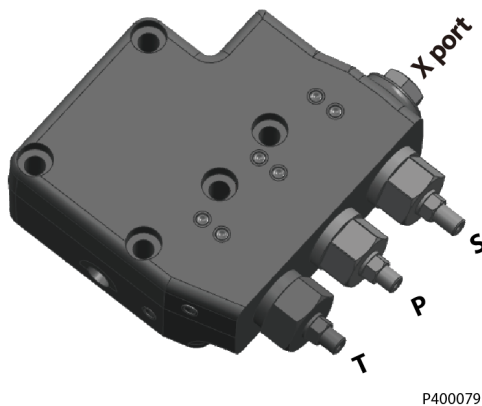
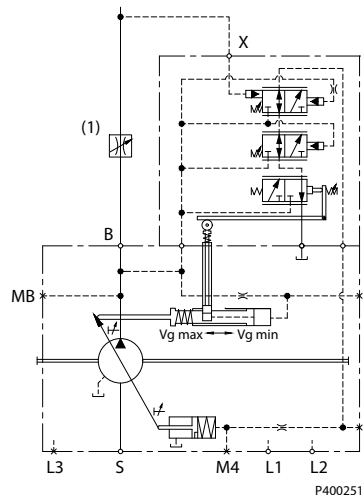

D1P 193/260+TPSN

*Control oil filter is optional

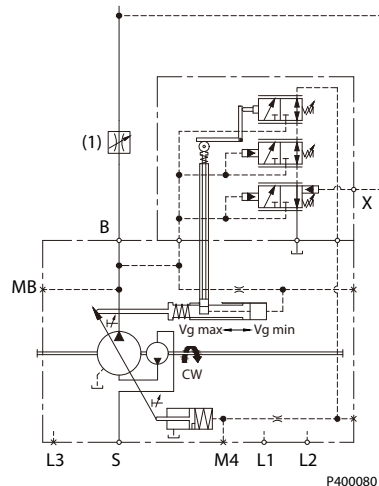

Power Control (T) Principle

The power control regulates the displacement of the pump depending on the working pressure so that a given drive power is not exceeded at constant drive speed, this function can prevent engine stall or protect electric generator.

$$P_B \cdot V_g = C$$

P_B = working pressure
 V_g = displacement
 C = constant

The precise control with a hyperbolic control characteristic, provides an optimum utilization of available power.

Control Type

Power Control (T) Operation

The working pressure acts on a rack-pivot via a roller jack which produces a rotating torque, an externally adjustable spring force counteracts this which determines the power setting.

If the moment generated by working pressure exceeds the moment generated by spring force, the control valve is actuated by the rack-pivot, and pump reduces displacement. The lever length at the rack-pivot is shortened and the working pressure can increase at the same rate as the displacement decreases without the drive powers being exceeded.

$$(P_B \cdot V_g = C).$$

The hydraulic output power (characteristic T) is influenced by the efficiency of the pump.

T characteristic

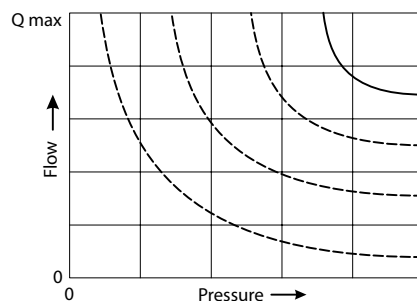

Pressure Compensated Control (P) Principle and Operation

Please refer to [NPNN \(Pressure Compensated Control\)](#) on page 27

Load Sensing Control (S) Principle and Operation

Please refer to [NPSN \(Pressure Compensated Control + Load Sensing Control\)](#) on page 29

TPSN Priority

The Pressure Compensated Control (P) has priority over the Power Control (T), Power Control has priority over Load Sensing Control (S).

Control Type

NNES (Electric Displacement Control + Load Sensing Control)

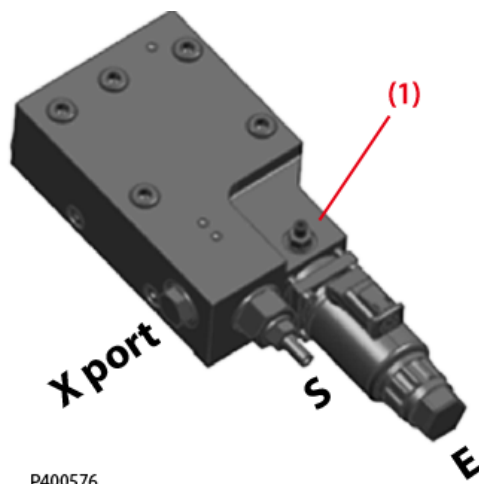

P400576

Warning

(1) Adjustment is not permissible

D1P 130/145/193/260 NNES

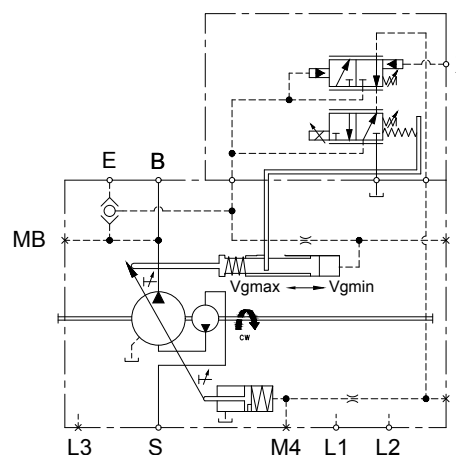

Electric Displacement Control (E) Principle

The electric displacement control uses an electric proportional solenoid valve to vary the pump's displacement from minimum displacement to maximum displacement or from maximum displacement to minimum displacement. The swashplate angle (pump displacement) is proportional to the electrical input signal (control current).

Electric Displacement Control (E) Operation

This control is current driven, requiring a Pulse Width Modulated (PWM) signal. Pulse width modulation allows more precise control of current to the solenoid. The PWM signal causes the solenoid pin to push against the E spool, which depressurizes the end of servo piston, the swashplate angle increases under the force of the bias piston

A swashplate feedback link provides swashplate position force to the solenoid through the E spool's linear spring. The control reaches equilibrium when the position of the swashplate spring feedback force exactly balances the input command solenoid force from the operator. As working pressure changes with load, the control and servo/swashplate system work constantly to maintain the commanded position of the swashplate.

Electric Displacement Control (E) Operating Instruction

To make sure the electric displacement control works properly, a minimum control pressure of 30 bar [435 psi] is required. The required control pressure is taken either from the working pressure, or from the externally applied control pressure at the E port.

If you can't make sure that the working pressure is above 30 bar all the time, then a minimum of 30bar [435 psi] pressure supply at the E port is mandatory in order to control the displacement of the pump at all times. This pressure supply can be provided from different sources, such as an additional small gear or piston pump and a relief valve, or an accumulator.

If E port is not connected, remove the shuttle valve

Control Type

Typical operating curve

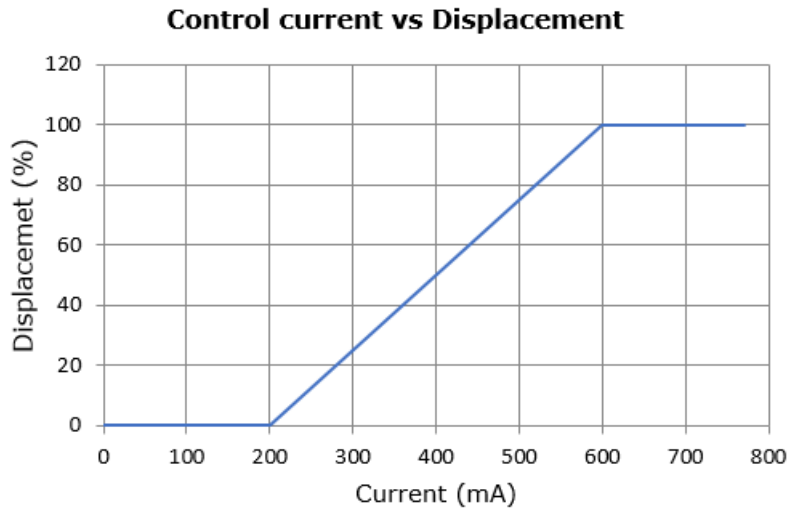

Hysteresis

EDC Hysteresis¹	
Input hysteresis	<4.5%
Output hysteresis @50% displacement	<4.0%

¹ Values may vary depending on application conditions. For more information, please contact Danfoss Power Solutions

Response/Recovery

Response/Recovery Times @ 1500rpm (50°C)¹		
Response 0%-100%	130cc (263 bar)	260 msec
	145cc (263 bar)	260 msec
	193cc (160 bar)	272 msec
	260cc (200 bar)	370 msec
Response 100%-0%	130cc (263 bar)	390 msec
	145cc (263 bar)	390 msec
	193cc (160 bar)	186 msec
	260cc (200 bar)	390 msec

MOR

Each Electric Displacement Control (EDC) is equipped with a Manual Over Ride (MOR) function for temporary actuation of the control to aid in diagnostics, even if insufficient or no current is supplied to the solenoid actuator. Initial activation of the MOR function will require a higher force to overcome the sticking effect between the pin and O-ring seal. Repeated activation of this functionality should provide better controllability.

Control Type

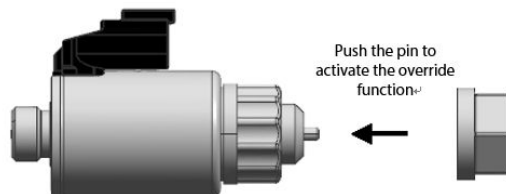

Warning

Do not actuate the MOR unless the machine is in a "SAFE" mode. Unintended MOR operation will cause the pump to go into stroke, use only for diagnosis purposes.

Solenoid Specification

Technical data - Solenoid

Voltage	24V (±20%)
Start current at Vg min.	200 mA
End Current at Vg max.	600 mA
Maximum current	770 mA
Coil Resistance @ 20 °C [70 °F]	22.7 Ω
PWM Range	70~200 Hz
PWM Frequency (preferred)*	100 Hz
IP Rating (IEC 60 529) + DIN 40 050, part 9	IP 67
IP Rating (IEC 60 529) + DIN 40 050, part 9 with mating connector	IP 69K

* PWM signal required for optimum control performance

Mating connector for Solenoid

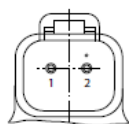

Description	Ordering Number	Quantity
Mating Connector	DEUTSCH DT06-2S	1
Wedge Lock	DEUTSCH W2S	1
Socket contact (16 and 18 AWG)	DEUTSCH 0462-201-16141	2
Danfoss mating connector kit	K29657	1
The mating connector is not included in the delivery contents, this can be delivered by Danfoss on request.		

Compatible PLUS+1® controllers(see below):

MC012	AI152986480902
MC024	AI152986480953
MC038	AI152886480992
MC050	AI152986480864
MC088	AI152886480776

For further information: please visit: <http://www.danfoss.com/Products/MobileElectronics/index.htm>

Control Type

Standard EDC Valve

The position of the connector can be changed by turning the solenoid body. Proceed as follows:

1. Loosen protection cap (1).
2. Loosen lock nut (2).
3. Turn the solenoid body (3) to the desired position.
4. Tighten the lock nut (2).
5. Tighten the protection cap (1).

Tightening Torque of lock nut: $5 \pm 1 \text{ N}\cdot\text{m}$ [44.25 \pm 8.85 lbf·in]

Standard EDC Valve

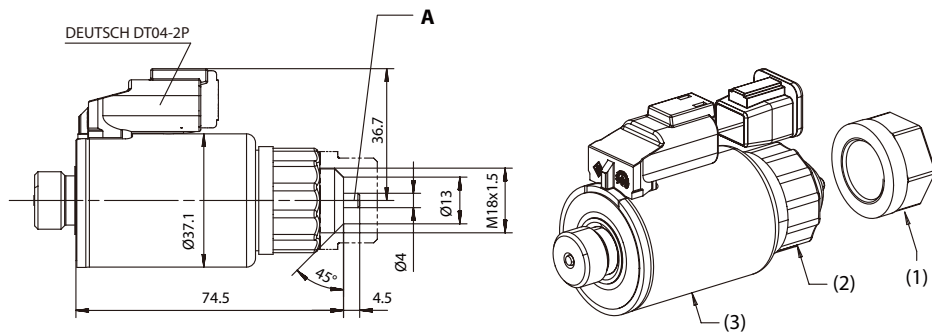

A - Actuation Forces	
Breakaway Force (First actuation)	45 N [10.12 lbf] max.
Repeat of Actuation	25 N [5.62 lbf] max.

NNES Priority

Both the Electric Displacement Control (EDC) and the Load Sensing Control (LS) are used to control the pump's displacement. The pump will output the smallest displacement when both control functions are given control instruct.

Control Type

TPE2/TPE5 (Power Control + Pressure Compensated Control + Electric Displacement Control)

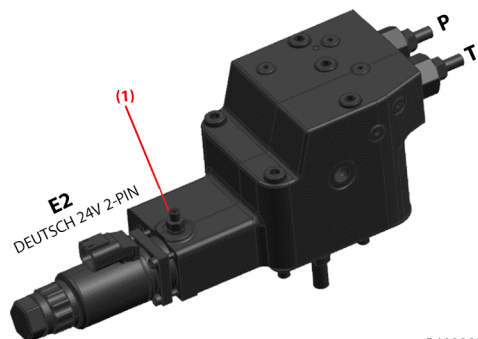

P400082

Warning

(1) Adjustment is not permissible

D1P 130/145+TPE5

D1P 193/260+TPE2

*Control oil filter is optional

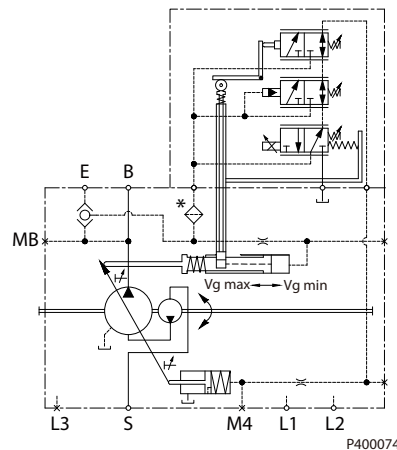

Power Control (T) Principle and Operation

Please refer to [TPSN \(Power Control + Pressure Compensated Control + Load Sensing Control\)](#) on page 33

Pressure Compensated Control (P) Principle and Operation

Please refer to [NPNN \(Pressure Compensated Control\)](#) on page 27

Electric Displacement Control (E2/E5) Principle and Operation

Please refer to [NNES \(Electric Displacement Control + Load Sensing Control\)](#) on page 35

TPE2/TPE5 Priority

The Pressure Compensated Control (P) has priority over the Power Control (T), and the Power Control (T) has priority over Electric Displacement Control (EDC).

Control Type

NPE2/NPE0 (Pressure Compensated Control + Electric Displacement Control)

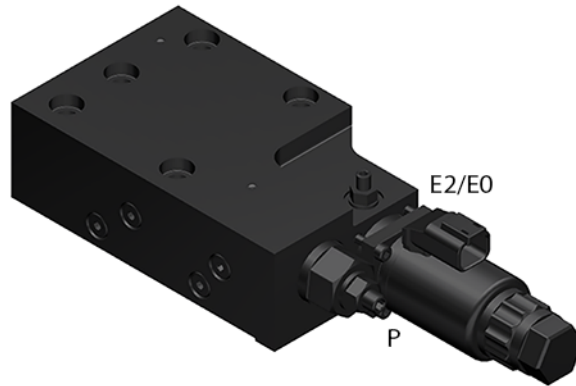

D1P 260 with NPE2 (left); D1P 260 with NPE0 (right)

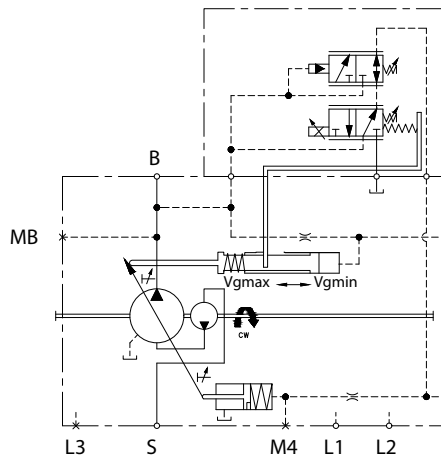
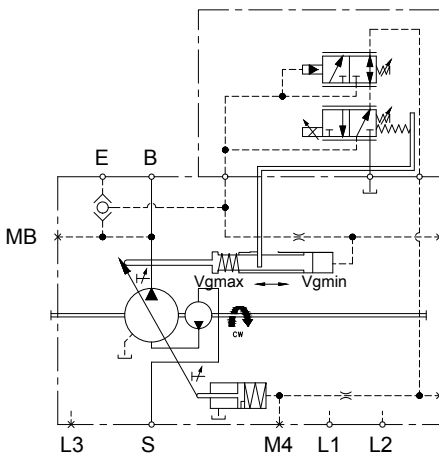

Pressure Compensated Control (P) Principle and Operation

Please refer to [NPNN \(Pressure Compensated Control\)](#) on page 27.

Electric Displacement Control (E2/E0) Principle and Operation

Please refer to [NNES \(Electric Displacement Control + Load Sensing Control\)](#) on page 35.

Shuttle Valve/Pilot Supply

Please refer to Electric Displacement Control (E) Operating Instruction section at [NNES \(Electric Displacement Control + Load Sensing Control\)](#) on page 35.

To determine if an external control pilot supply is needed, please consult your Danfoss Power Solutions representative.

D1P pumps configured with an NPE2 control will come with a shuttle valve installed at the E port. D1P pumps with an NPE0 control will not include the shuttle valve.

Installation Drawings

Size 130/145

Dimensions (mm) and port descriptions

Size 130/145: TPSN w/o Charge Pump

Control : TPSN

Power Control (T) + Pressure Compensated Control (P) + Load Sensing Control (S)

Auxiliary flange : NN (No Auxiliary flange)

Charge pump : Without

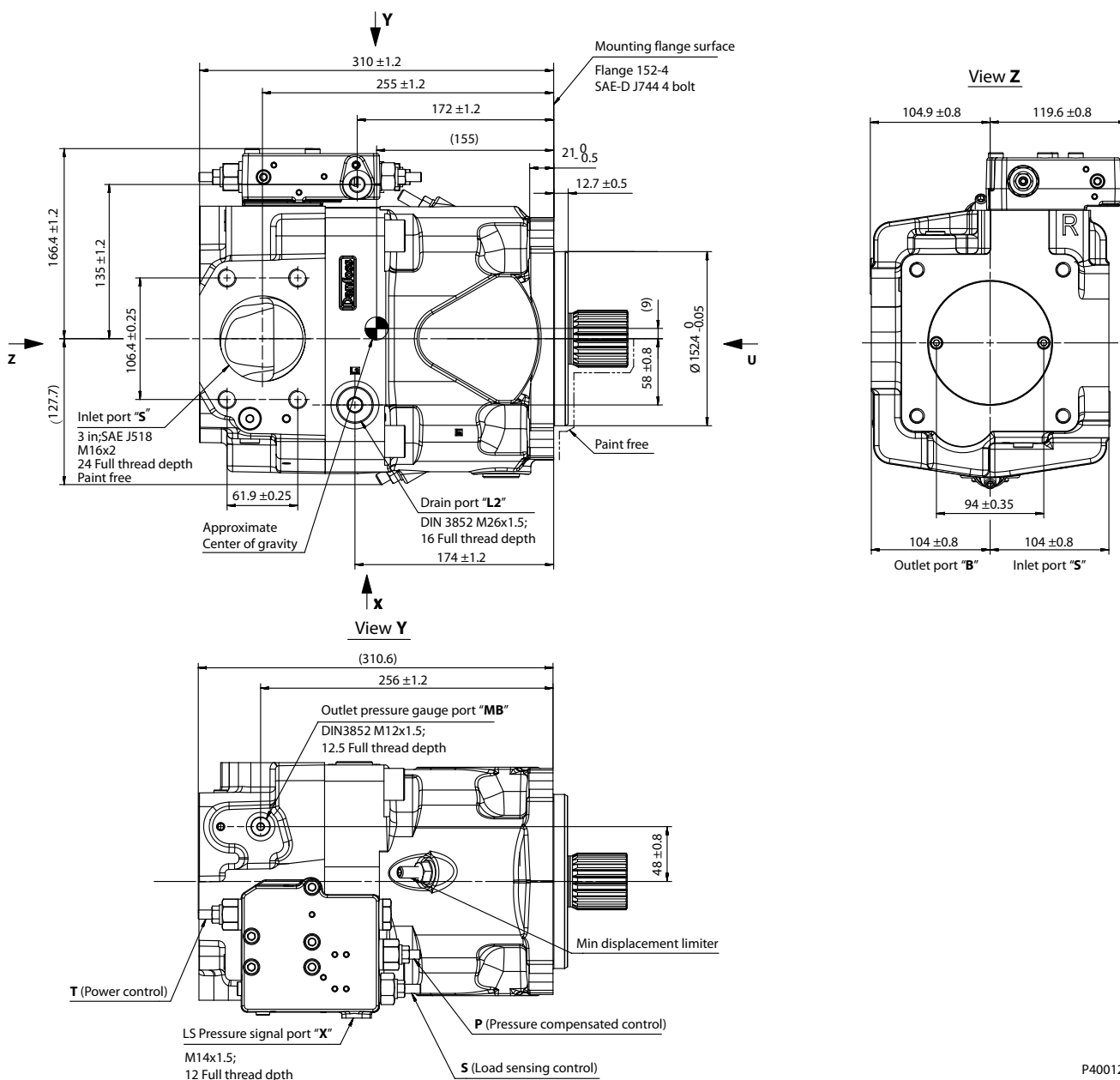

P400120

Before finalizing your design, please request a certified drawing.

Installation Drawings

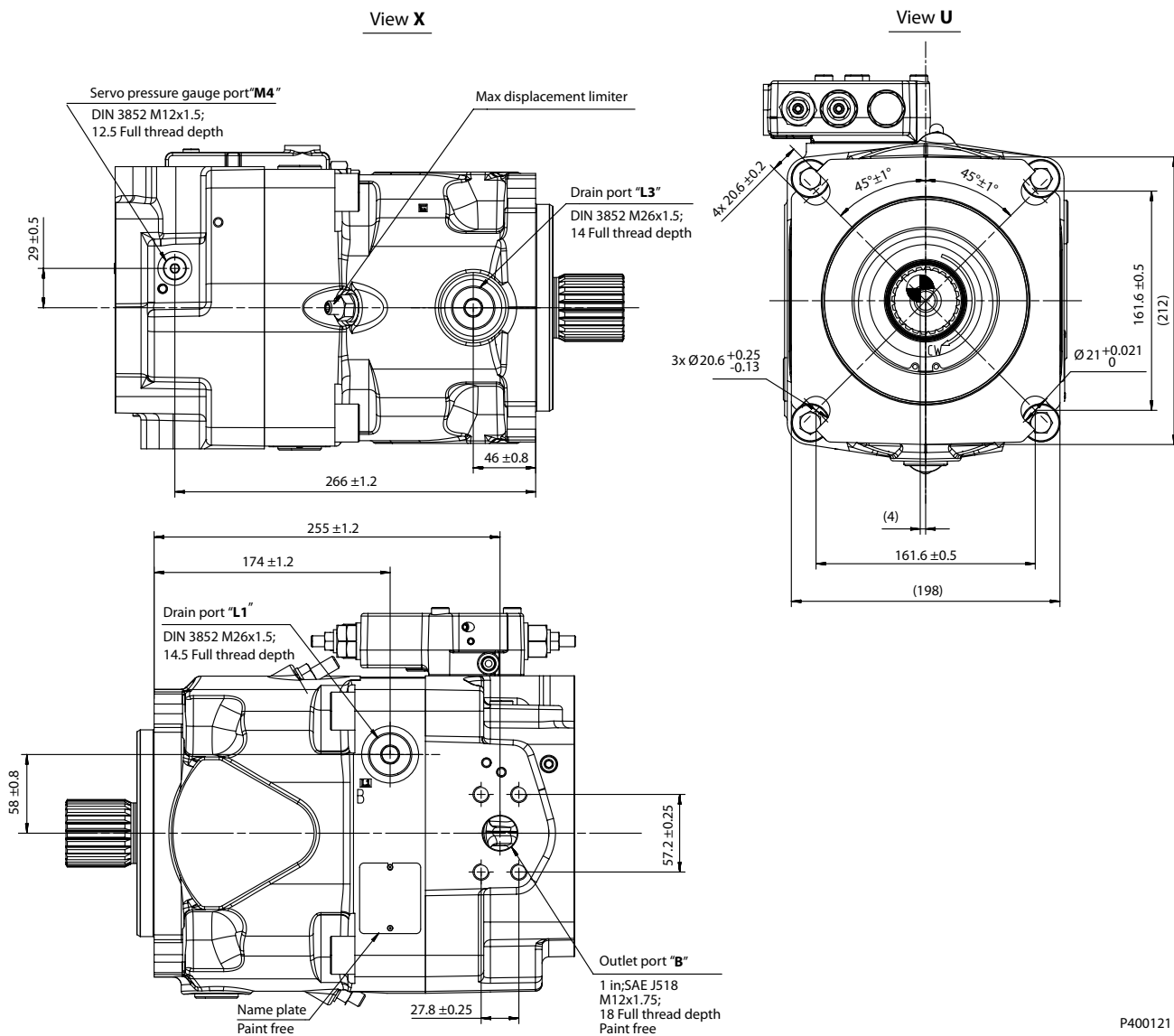

Before finalizing your design, please request a certified drawing.

Port Descriptions

Ports	Description	Standard	Size ¹⁾	Max. pressure (bar [psi])	State ²⁾
B	Outlet port, Fixing thread	SAE J518, DIN13	1 in, M12 x 1.75; 18 deep	400 [5802]	O
S	Suction port, Fixing thread	SAE J518, DIN13	3 in, M16 x 2; 24 deep	2 [29]	O
L ₁ , L ₂ , L ₃	Drain port	DIN 3852	M26 x 1.5; 14.5, 16, 14 deep	2 [29]	X ³⁾
M ₄	Measurement point, servo-piston chamber	DIN 3852	M12 x 1.5; 12.5 deep	400 [5802]	X
M _B	Measurement point, outlet port	DIN 3852	M12 x 1.5; 12.5 deep	400 [5802]	X
X	LS port	DIN 3852	M14 x 1.5; 12.5 deep	400 [5802]	O

¹⁾ For required torque, please refer to *D1P tightening torque* on page 79.

²⁾ O = Open, must be connected (closed by plastic plug on delivery) / X = Closed (closed by metal plug on delivery).

³⁾ Depending on installation position, one of L₁, L₂ and L₃ must be connected (please refer to Installation Notes).

Installation Drawings

Size 130/145: TPE5 w/o Charge Pump

Control : TPE5

Power Control (T) + Pressure Compensated Control (P) + Electric Displacement Control (E5)

Auxiliary flange : B1

Charge pump : Without

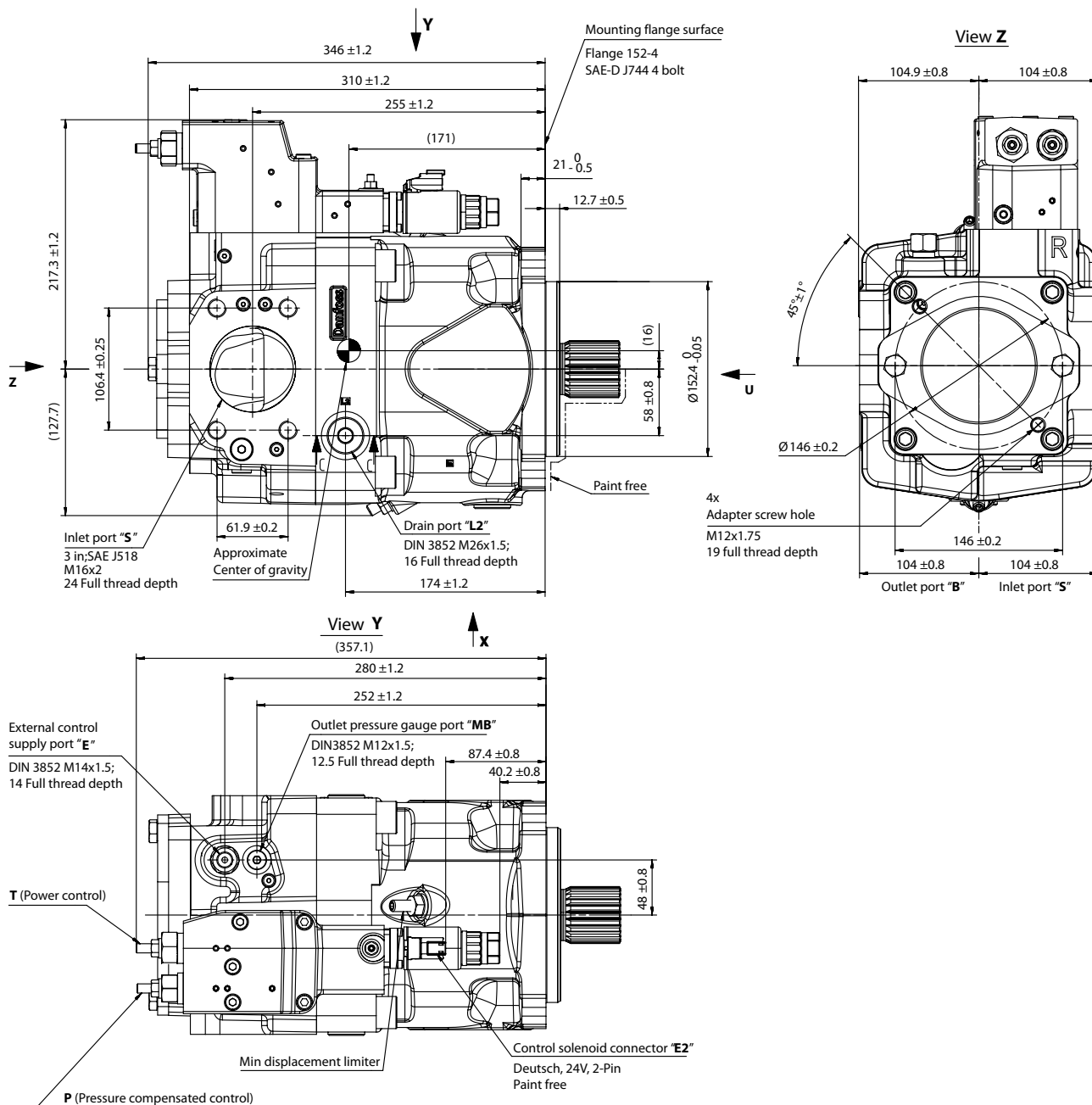

P400422

Before finalizing your design, please request a certified drawing.

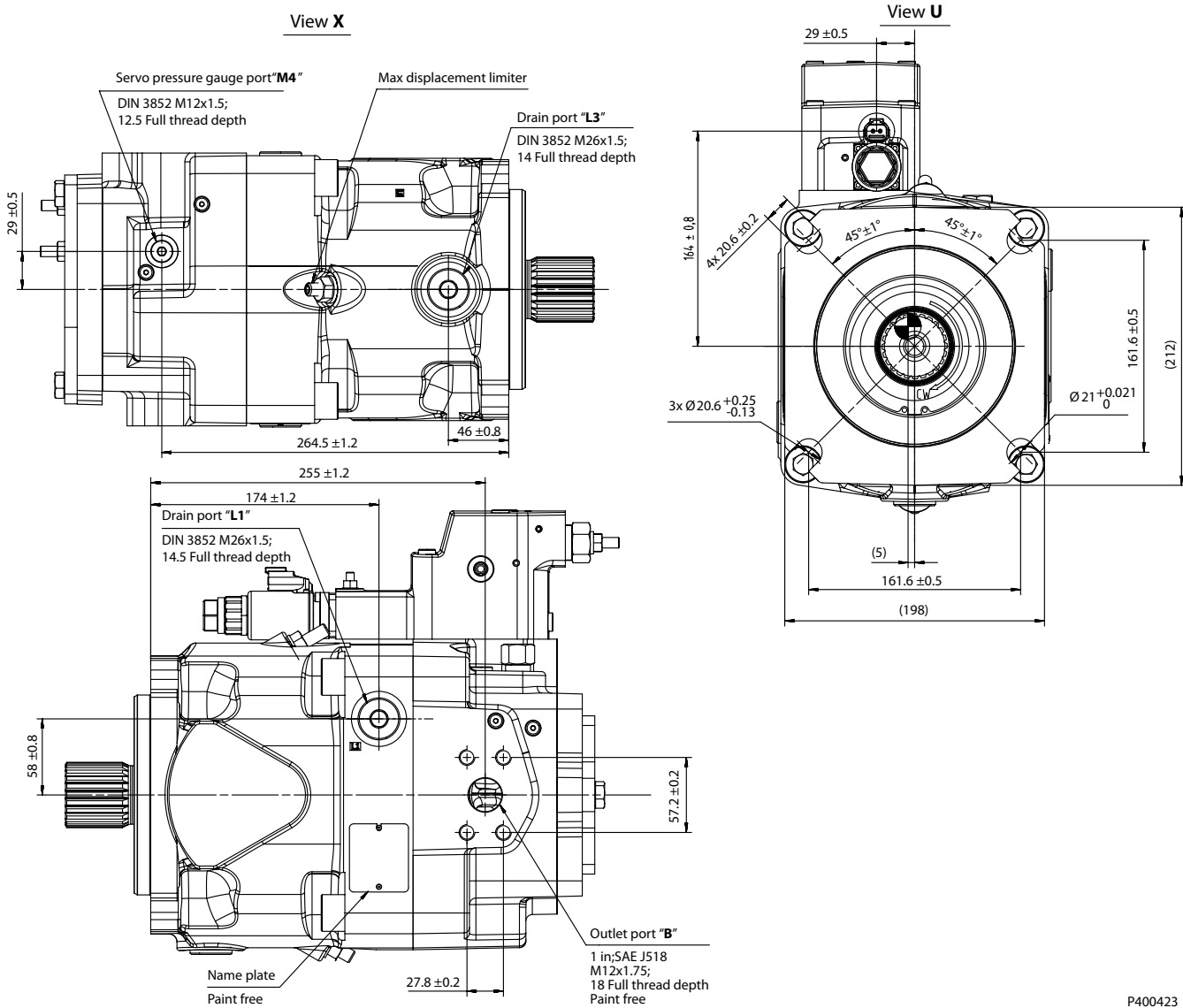
Installation Drawings

P400423

Before finalizing your design, please request a certified drawing.

Port Descriptions

Ports	Description	Standard	Size ¹⁾	Max. pressure (bar [psi])	State ²⁾
B	Outlet port, Fixing thread	SAE J518, DIN13	1 in, M12 x 1.75; 18 deep	400 [5802]	O
S	Suction port, Fixing thread	SAE J518, DIN13	3 in, M16 x 2; 24 deep	2 [29]	O
L₁, L₂, L₃	Drain port	DIN 3852	M26 x 1.5; 14.5, 16, 14 deep	2 [29]	X ³⁾
M₄	Measurement point, servo-piston chamber	DIN 3852	M12 x 1.5; 12.5 deep	400 [5802]	X
M_B	Measurement point, outlet port	DIN 3852	M12 x 1.5; 12.5 deep	400 [5802]	X
E	External control port	DIN 3852	M14 x 1.5; 12 deep	200 [2901]	X

¹⁾ For required torque, please refer to [D1P tightening torque](#) on page 79.

²⁾ O = Open, must be connected (closed by plastic plug on delivery) / X = Closed (closed by metal plug on delivery).

³⁾ Depending on installation position, one of L₁, L₂ and L₃ must be connected (please refer to Installation Notes).

Installation Drawings

Size 130/145: TPSN w/ Charge pump

Control : TPSN

Power Control (T) + Pressure Compensated Control (P) + Load Sensing Control (S)

Auxiliary flange : B1

Charge pump : With

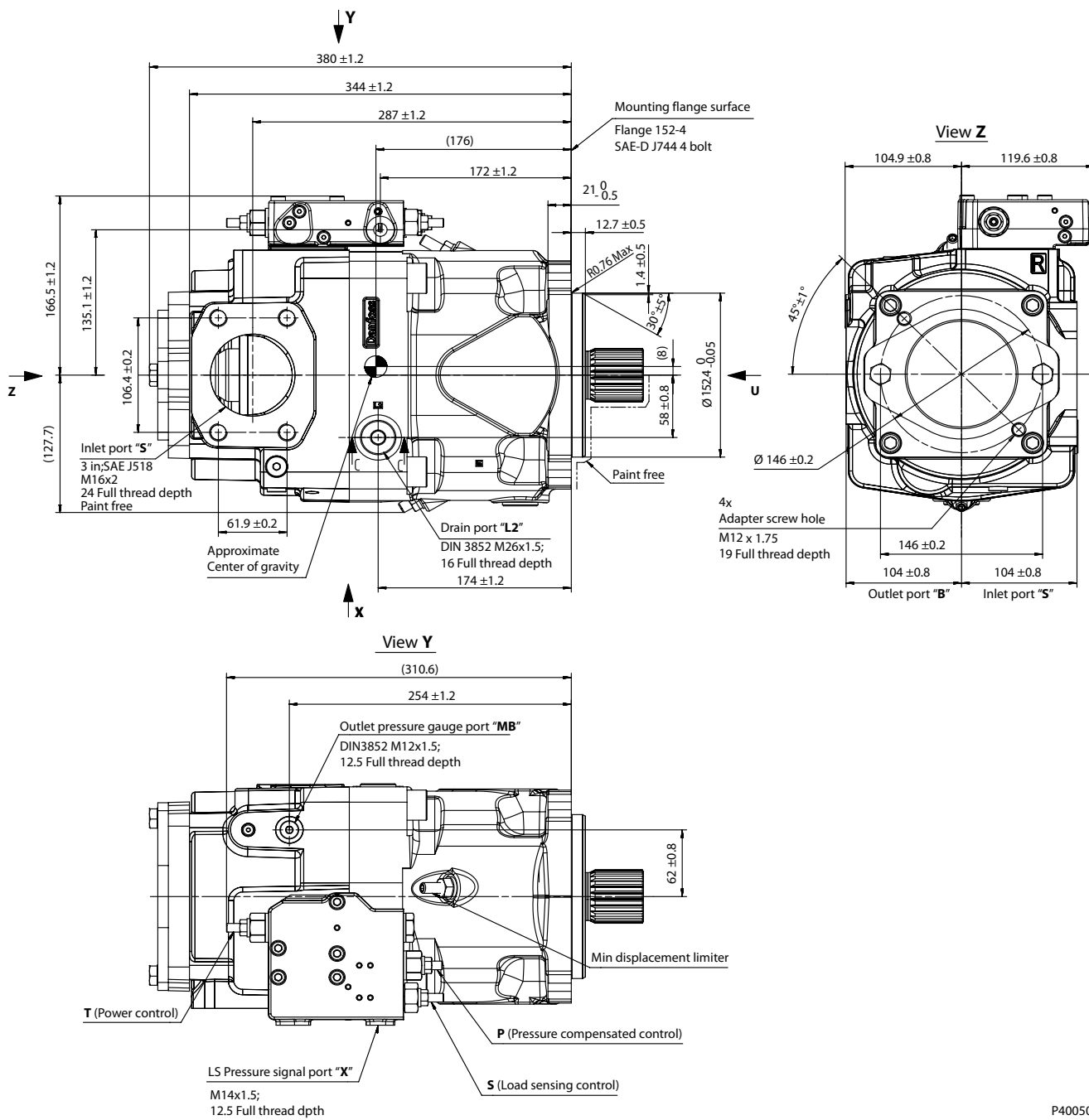

P400508

Before finalizing your design, please request a certified drawing.

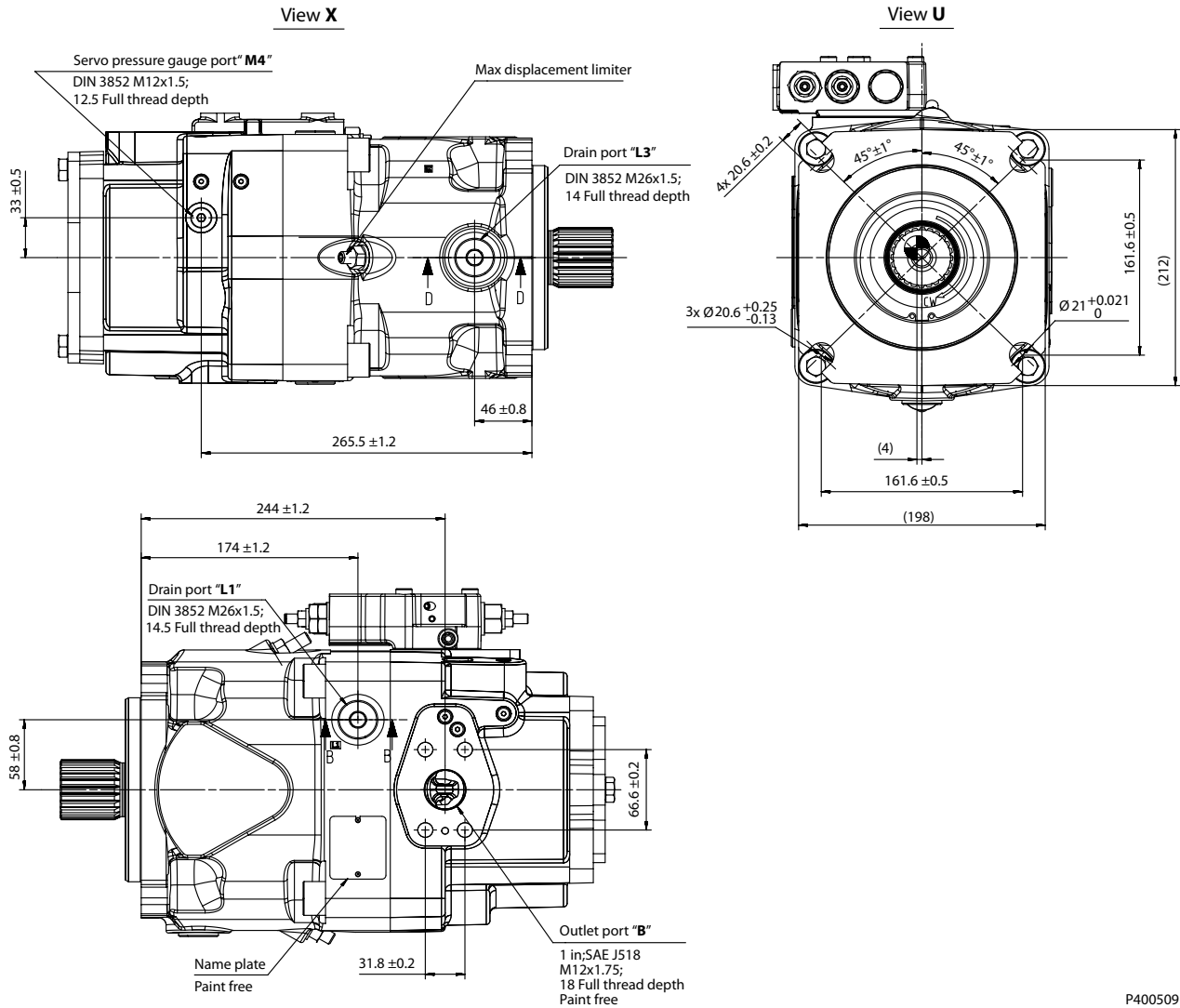
Installation Drawings

P400509

Before finalizing your design, please request a certified drawing.

Port Descriptions

Ports	Description	Standard	Size ¹⁾	Max. pressure (bar [psi])	State ²⁾
B	Outlet port, Fixing thread	SAE J518, DIN13	1 ¼ in, M14 x 2; 23 deep	400 [5802]	O
S	Suction port, Fixing thread	SAE J518, DIN13	3 in, M16 x 2; 24 deep	2 [29]	O
L₁, L₂, L₃	Drain port	DIN 3852	M26 x 1.5; 14.5, 16, 14 deep	2 [29]	X ³⁾
M₄	Measurement point, servo-piston chamber	DIN 3852	M12 x 1.5; 12.5 deep	400 [5802]	X
M_B	Measurement point, outlet port	DIN 3852	M12 x 1.5; 12.5 deep	400 [5802]	X
X	LS port	DIN 3852	M14 x 1.5; 12.5 deep	400 [5802]	X

¹⁾ For required torque, please refer to [D1P tightening torque](#) on page 79.

²⁾ O = Open, must be connected (closed by plastic plug on delivery) / X = Closed (closed by metal plug on delivery).

³⁾ Depending on installation position, one of L₁, L₂ and L₃ must be connected (please refer to Installation Notes).

Installation Drawings

Size 130/145: TPE5 w/ Charge Pump

Control : TPE5

Power Control (T) + Pressure Compensated Control (P) + Electric Displacement Control (E5)

Auxiliary flange : B1

Charge pump : With

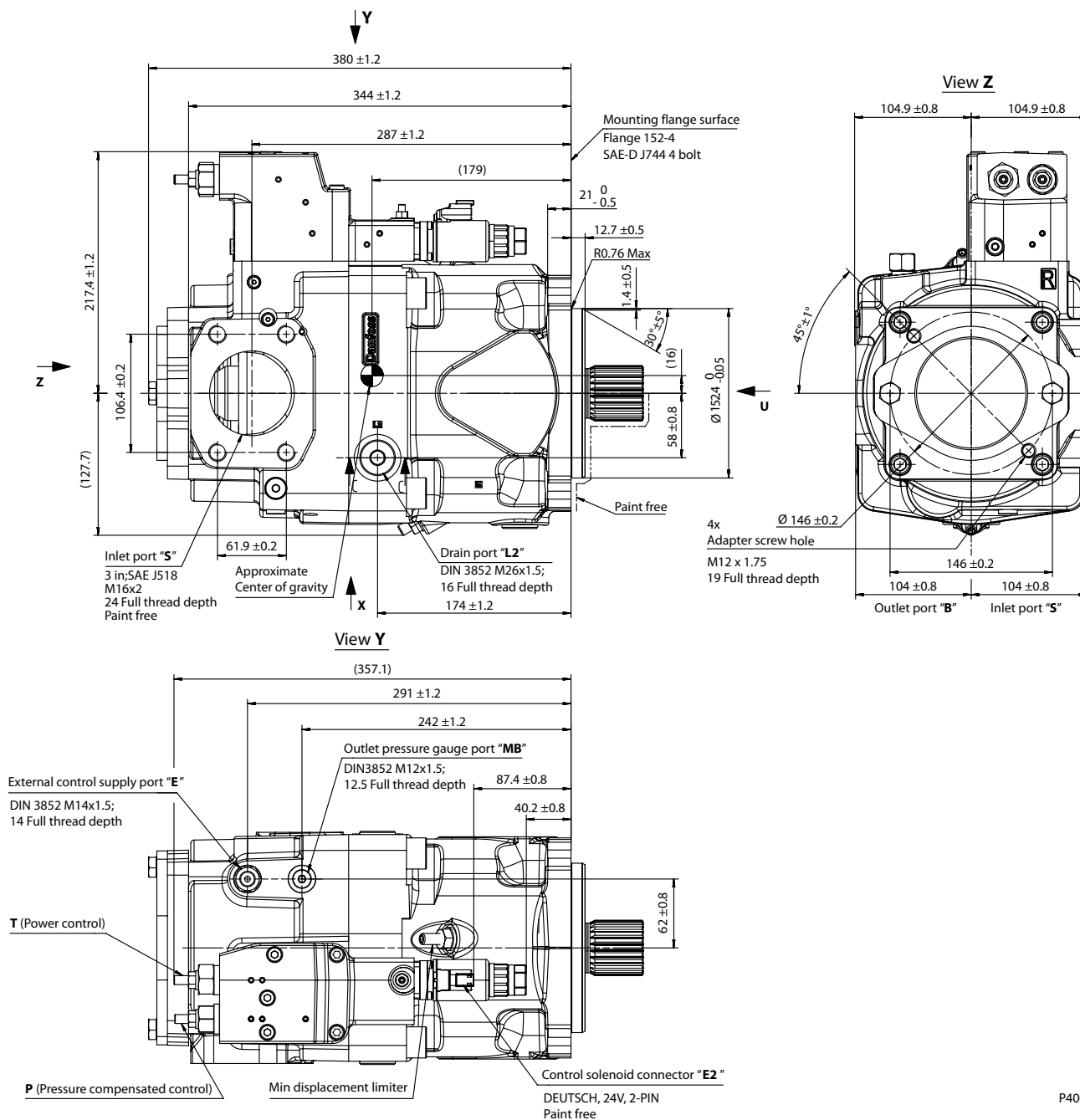

P400510

Before finalizing your design, please request a certified drawing.

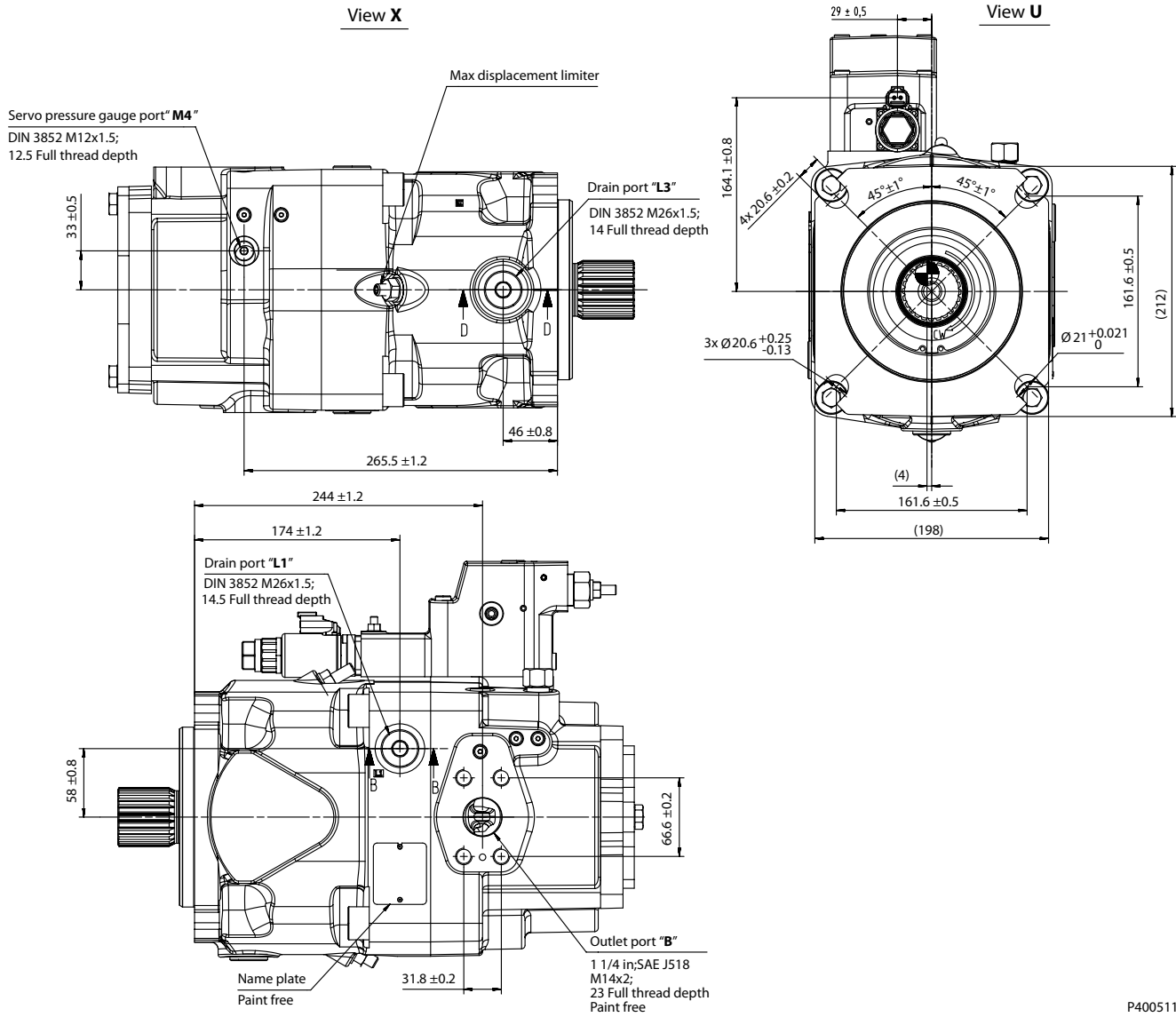
Installation Drawings

P400511

Before finalizing your design, please request a certified drawing.

Port Descriptions

Ports	Description	Standard	Size ¹⁾	Max. pressure (bar [psi])	State ²⁾
B	Outlet port, Fixing thread	SAE J518, DIN13	1 ¼ in, M14 x 2; 23 deep	400 [5802]	O
S	Suction port, Fixing thread	SAE J518, DIN13	3 in, M16 x 2; 24 deep	2 [29]	O
L₁, L₂, L₃	Drain port	DIN 3852	M26 x 1.5; 14.5, 16, 14 deep	2 [29]	X ³⁾
M₄	Measurement point, servo-piston chamber	DIN 3852	M12 x 1.5; 12.5 deep	400 [5802]	X
M_B	Measurement point, outlet port	DIN 3852	M12 x 1.5; 12.5 deep	400 [5802]	X
E	External control port	DIN 3852	M14 x 1.5; 12 deep	200 [2901]	X

¹⁾ For required torque, please refer to [D1P tightening torque](#) on page 79.

²⁾ O = Open, must be connected (closed by plastic plug on delivery) / X = Closed (closed by metal plug on delivery).

³⁾ Depending on installation position, one of L₁, L₂ and L₃ must be connected (please refer to Installation Notes).

Installation Drawings

Input shaft

D1P 130/145 shaft specifications

Shaft torque and dimensions

Code	Description	Maximum Torque Rating	Drawing
T	Splined shaft DIN 5480, W50 x 2 x 30 x 24 x 9g	3100 N·m [27437 lbf·in]	<p> Mating coupling must not protrude beyond this point Paint free Spline data Number of teeth : 24 Modules : 2 Pressure angle : 30° Pitch Ø : Ø48 Type of fit : Flat root side Per : DIN 5480 Class 9g </p> <p> 10 ± 0.8 12 ± 2 5.2 ± 0.5 Ø44.5 ± 0.12 Ø49.6 ± 0.16 Ø105.5 ± 0.25 36 ± 2 Full thd 43.5 - 0.5 45 ± 1 (65) M16 x 2-6H THD Ø17 ± 0.2 Ø23 ± 0.2 Mounting flange Flange 152-4 Per SAE J744 </p> <p>Min. active spline length⁽²⁾: 43.5 mm [1.71 in]</p> <p>P400085</p>
S	Splined shaft SAE J744, 1 3/4 in. 13T, 8/16 DP	1528 N·m [13524 lbf·in]	<p> Mating coupling must not protrude beyond this point Paint free Spline data Number of teeth : 13 Pitch fraction : 8/16 Pressure angle : 30° Pitch Ø : Ø41.275 Type of fit : Fillet root side Per : ANSI B92.1-1996. Class 5 </p> <p> 10 ± 0.8 12 ± 2 5.2 ± 0.5 Ø34.5 ± 0.1 Ø44.45 ± 0.127 Ø105.5 ± 0.25 36 ± 2 Full thd 44 ± 1 55 - 0.5 (77) 5/8-11 UNC-2B THD Ø17 ± 0.2 Ø23 ± 0.2 Mounting flange Flange 152-4, Per SAE J744 </p> <p>Min. active spline length⁽²⁾: 55 mm [2.71 in]</p> <p>P400424</p>

Installation Drawings

Shaft torque and dimensions (continued)

Code	Description	Maximum Torque Rating	Drawing
P	Straight keyed shaft, DIN 6885, AS14 x 9 x 80	1411 N·m [12488 lbf·in]	<p style="text-align: right;">P400512</p>
K	SAE J744 (D/E) 3in straight keyed shaft, 0.4375 x 3.000 in	1787 N·m [15816 lbf·in]	

- 1) Center bore according to DIN 332 (thread according to DIN 13)
- 2) Minimum active spline length for the specified torque ratings

Installation Drawings

Aux mounting flange

Size 130/145: Option NN (No Coupling)

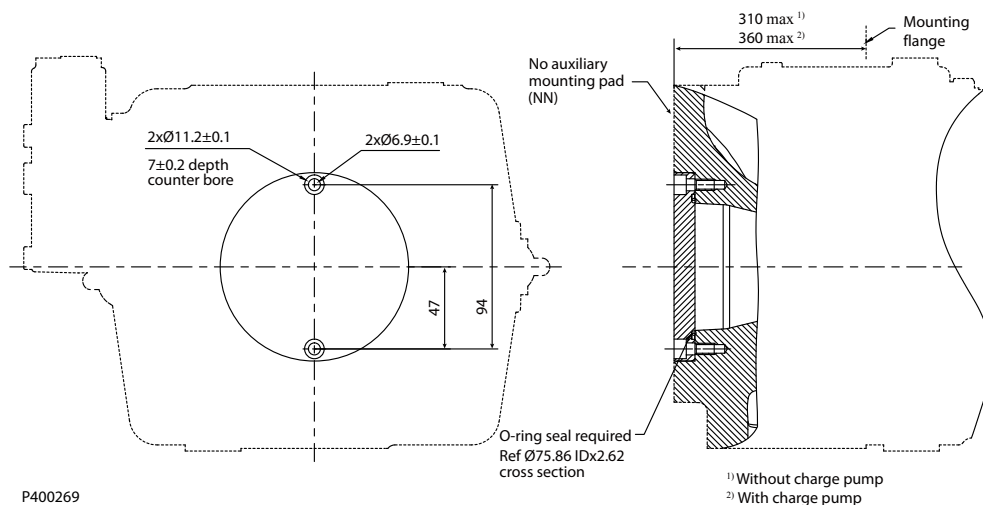

P400269

Specifications

Option	Coupling
NN	No coupling

Size 130/145: Option A1 (SAE-A, 9 teeth)

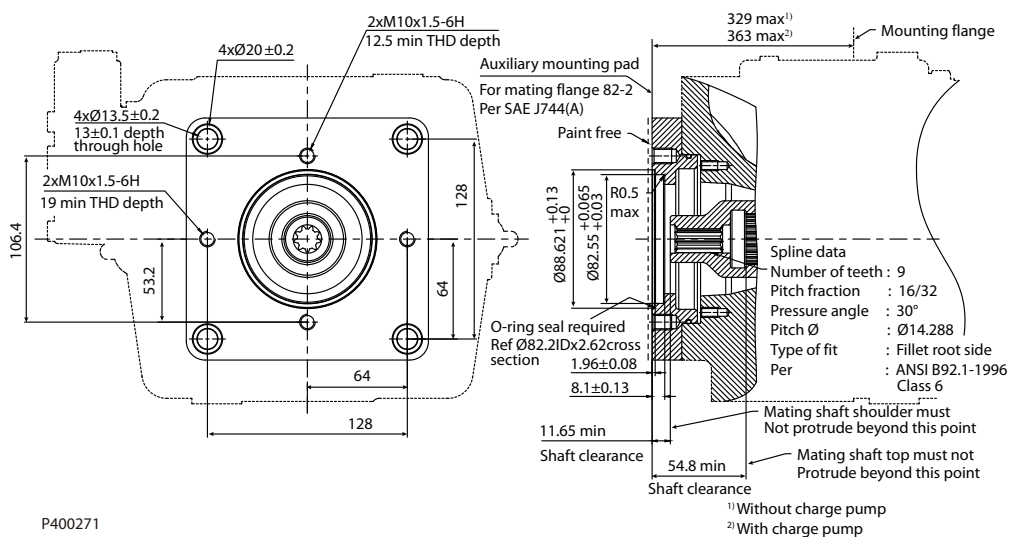

P400271

Specifications

Option	Coupling	Max torque
A1	5/8 in, 9T, 16/32 DP	205 N•m [1814.40 lbf•in]

Installation Drawings

Size 130/145: Option B1 (SAE-B, 13 teeth)

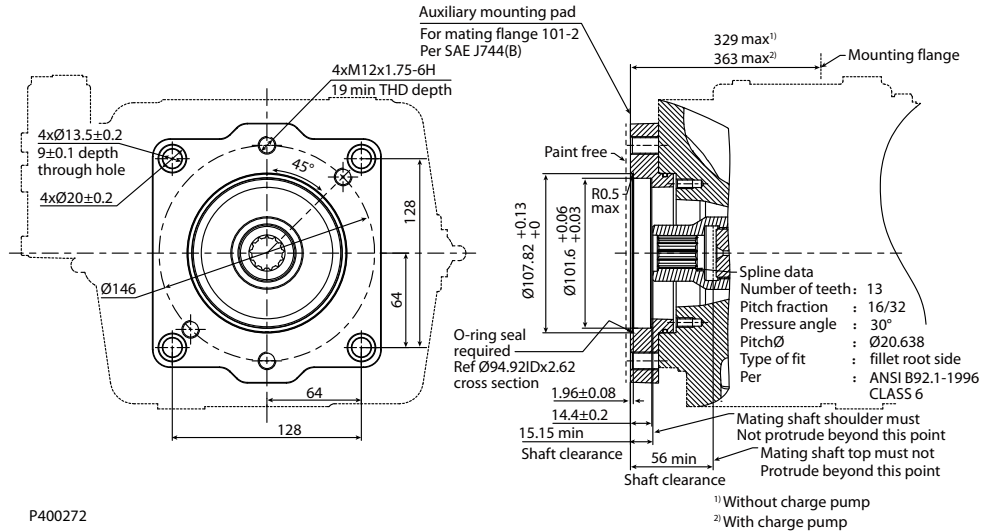

Specifications

Option	Coupling	Max torque
B1	7/8 in, 13T, 16/32 DP	411 N·m [3637.66 lbf·in]

Size 130/145: Option C5 (SAE-C, 14 teeth)

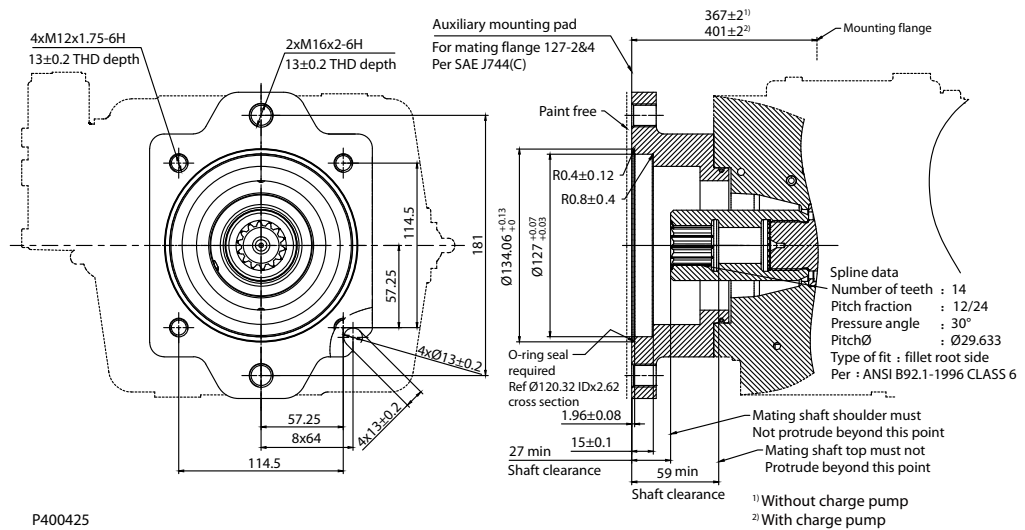

Specifications

Option	Coupling	Max torque
C5	1 ¼ in, 14T 12/24 DP	1164 N·m [10302.27 lbf·in]

Installation Drawings

Size 130/145: Option D5 (SAE-D, 24 teeth)

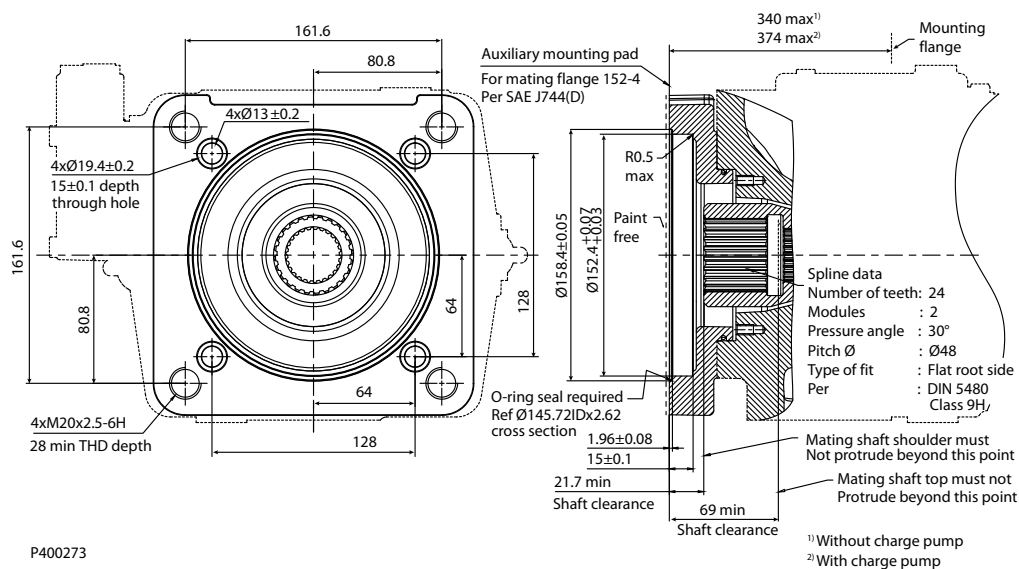

Specifications

Option	Coupling	Max torque
D5	N50 x 2 x 30 x 24 x 9H	1164 N·m [10302.27 lbf·in]

[Before finalizing your design, please request a certified drawing.](#)

Installation Drawings

Size 193

Dimensions (mm) and port descriptions

Size 193: TPE2 w/ Charge Pump

Control : TPE2

Power Control (T) + Pressure Compensated Control (P) + Electric Displacement Control (E2)

Auxiliary flange : B1

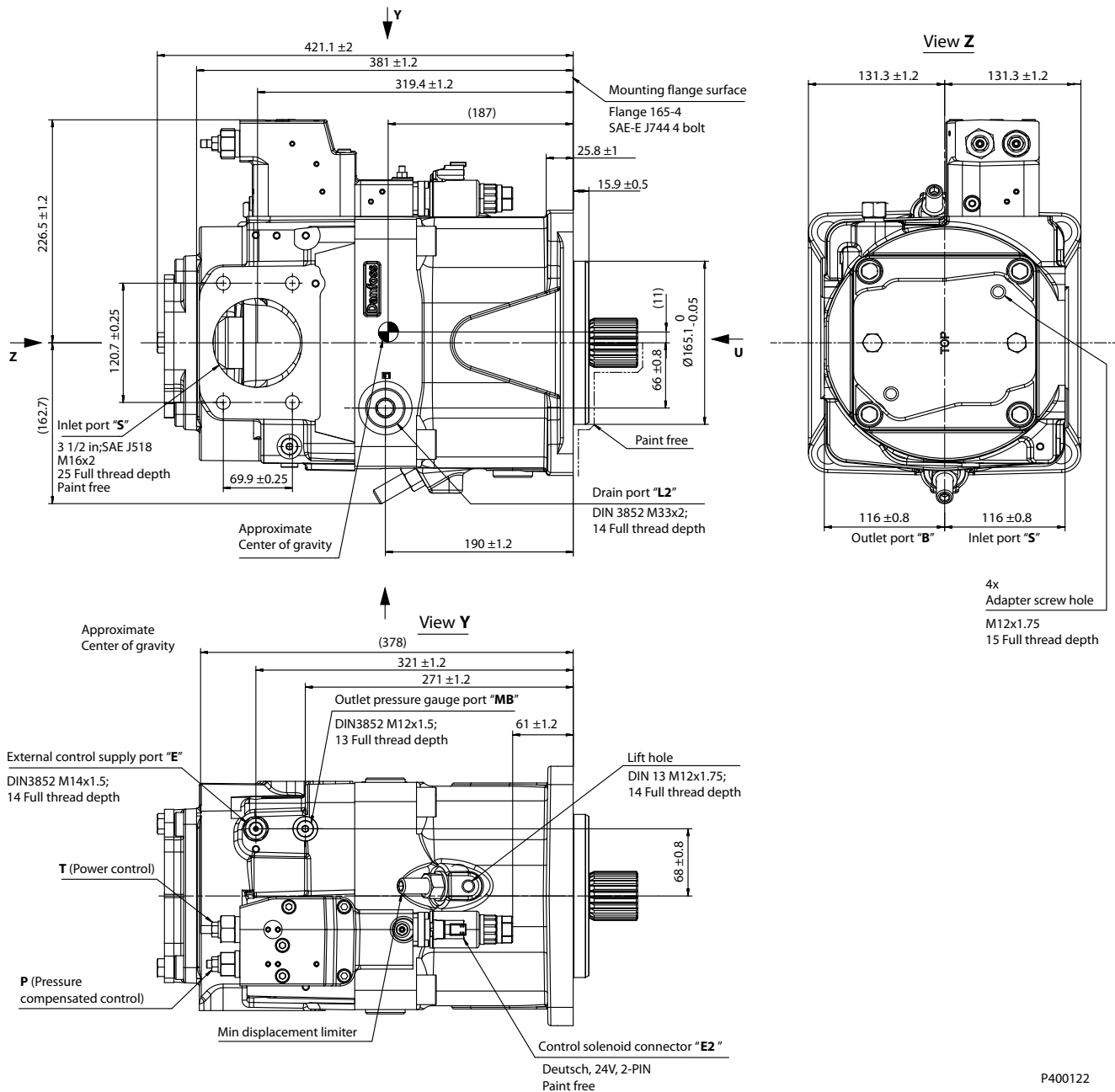

P400122

Before finalizing your design, please request a certified drawing.

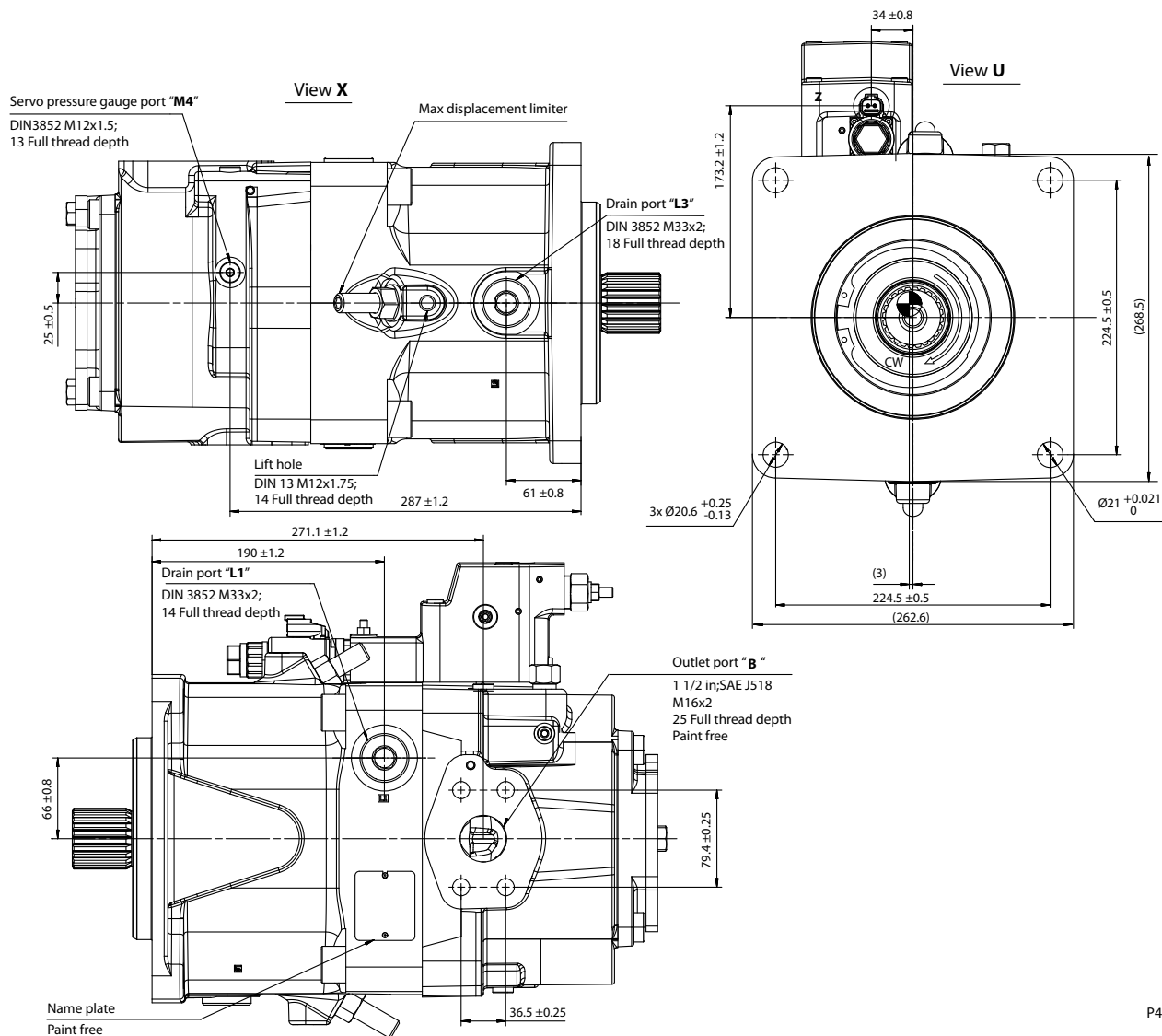
Installation Drawings

P400123

[Before finalizing your design, please request a certified drawing.](#)

Port Descriptions

Ports	Description	Standard	Size ¹⁾	Max. pressure (bar [psi])	State ²⁾
B	Outlet port, Fixing thread	SAE J518, DIN13	1 1/2 in, M16 x 2; 25 deep	400 [5802]	O
S	Suction port, Fixing thread	SAE J518, DIN13	3 1/2 in, M16 x 2; 25 deep	2 [29]	O
L₁, L₂, L₃	Drain port	DIN 3852	M33 x 2; 14,14, 18 deep	2 [29]	X ³⁾
M₄	Measurement point, servo-piston chamber	DIN 3852	M12 x 1.5; 13 deep	400 [5802]	X
M_B	Measurement point, outlet port	DIN 3852	M12 x 1.5; 13 deep	400 [5802]	X
E	External control port	DIN 3852	M14 x 1.5; 14 deep	200 [2901]	X ⁴⁾

¹⁾ For required torque, please refer to [DIP tightening torque](#) on page 79

²⁾ O = Open, must be connected (closed by plastic plug on delivery) / X = Closed (closed by metal plug on delivery)

³⁾ Depending on installation position, one of L₁, L₂ and L₃ must be connected (please refer to Installation Notes).

⁴⁾ If E port is not used, remove the shuttle valve and lock port by seal plug.

Installation Drawings

Size 193: TPSN w/ Charge Pump

Control : TPSN

Power Control (T) + Pressure Compensated Control (P) + Load Sensing Control (S)

Auxiliary flange : NN

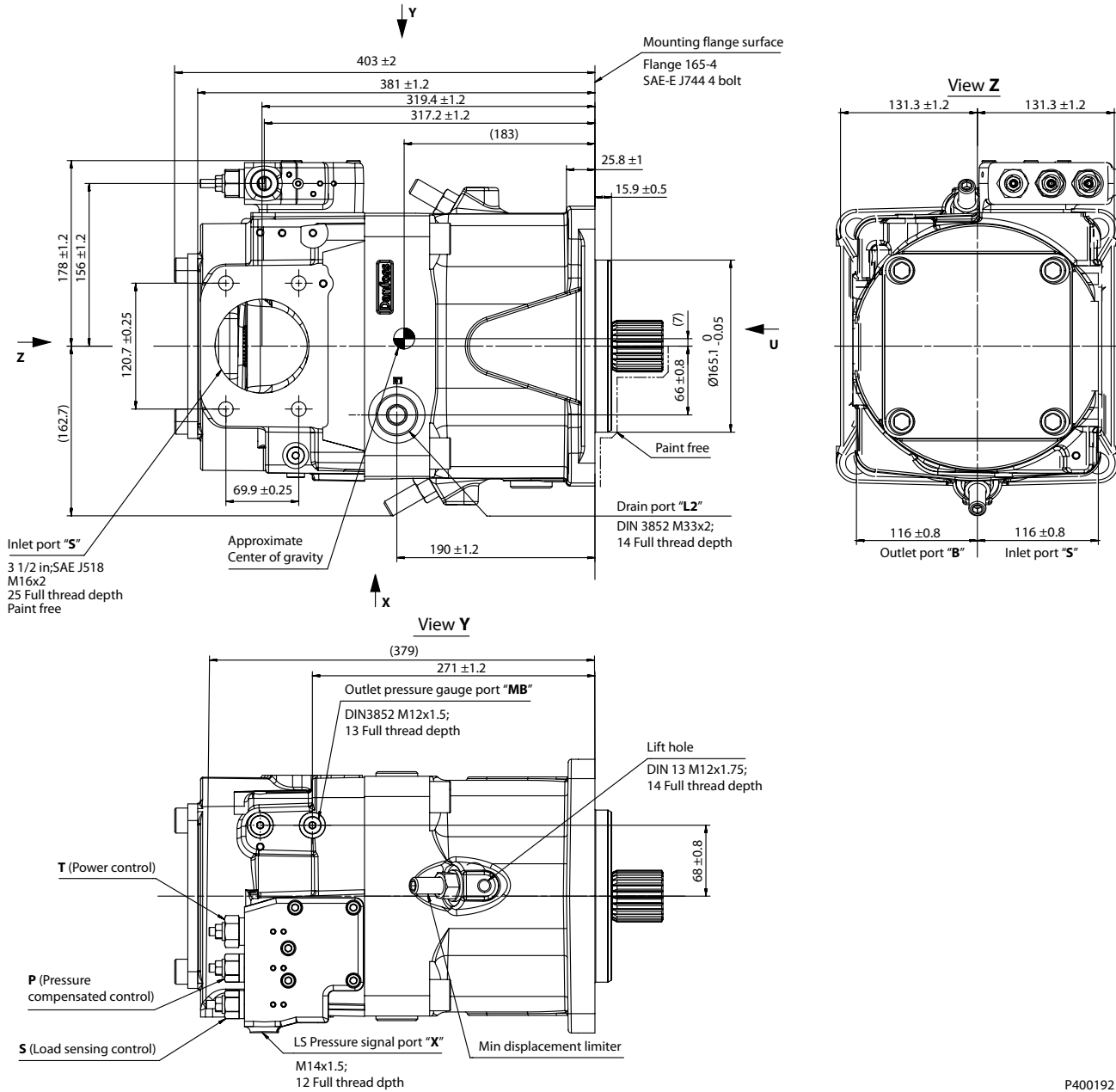

P400192

Before finalizing your design, please request a certified drawing.

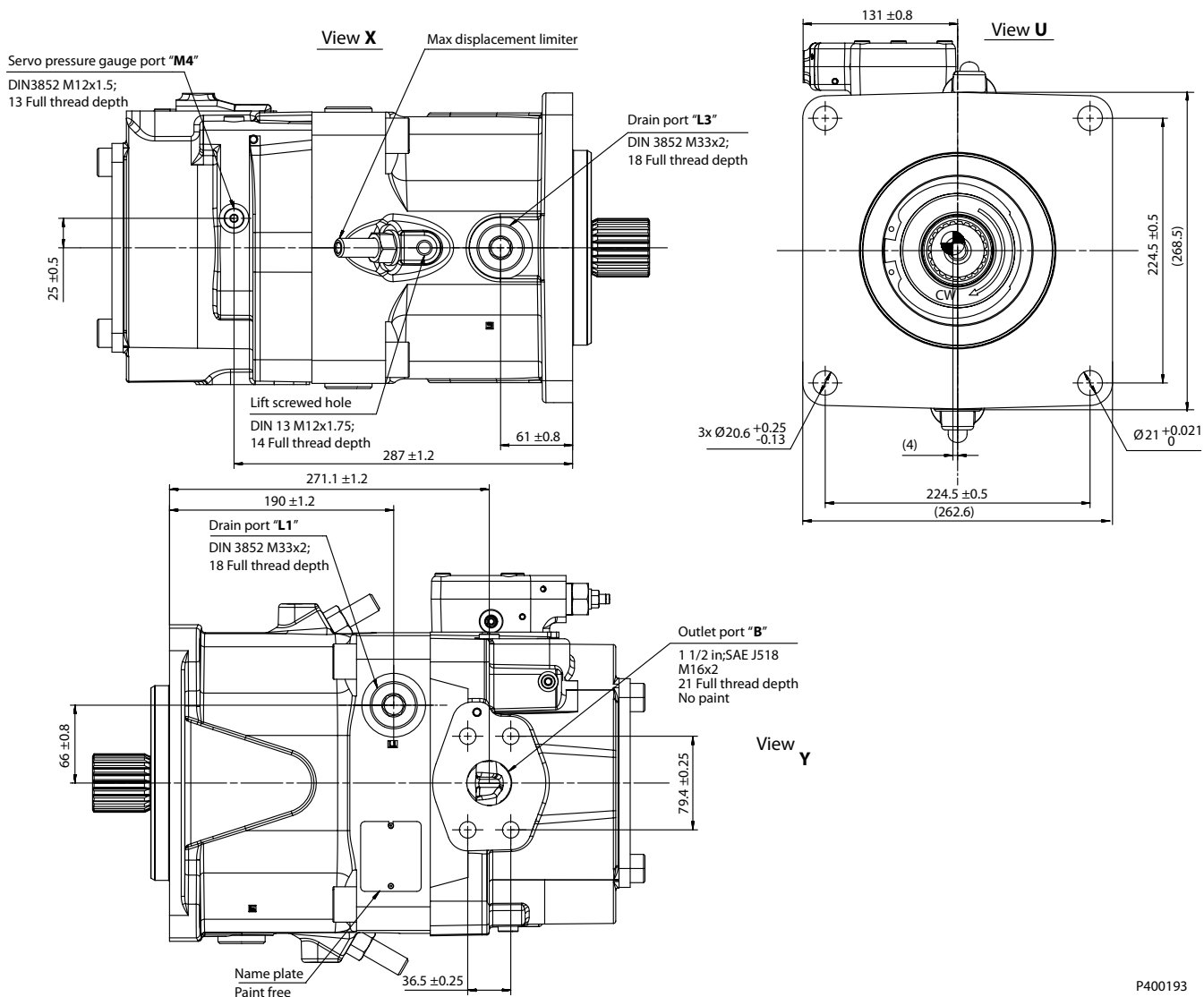
Installation Drawings

Before finalizing your design, please request a certified drawing.

Port Descriptions

Ports	Description	Standard	Size ¹⁾	Max. pressure (bar [psi])	State ²⁾
B	Outlet port, Fixing thread	SAE J518, DIN13	1 1/2 in, M16 x 2; 25 deep	400 [5802]	O
S	Suction port, Fixing thread	SAE J518, DIN13	3 1/2 in, M16 x 2; 25 deep	2 [29]	O
L₁, L₂, L₃	Drain port	DIN 3852	M33 x 2; 14, 14, 18 deep	2 [29]	X ³⁾
M₄	Measurement point, servo-piston chamber	DIN 3852	M12 x 1.5; 13 deep	400 [5802]	X
M_B	Measurement point, outlet port	DIN 3852	M12 x 1.5; 13 deep	400 [5802]	X
X	LS port	DIN 3852	M14 x 1.5; 12 deep	400 [5802]	O

¹⁾ For required torque, please refer to [DIP tightening torque](#) on page 79.

²⁾ O = Open, must be connected (closed by plastic plug on delivery) / X = Closed (closed by metal plug on delivery).

³⁾ Depending on installation position, one of L₁, L₂ and L₃ must be connected (please refer to Installation Notes).

Installation Drawings

Input shaft

D1P 193 shaft specifications

Code	Description	Maximum Torque Rating	Drawing
T	Splined shaft DIN 5480, W50 x 2 x 30 x 24 x 9g	3100 N·m [27437 lbf·in]	<p>Min. active spline length⁽²⁾: 44 mm [1.73 in]</p>
S	Splined shaft SAE J744, 1 3/4 in, 13T, 8/16 DP	1536 N·m [13595 lbf·in]	<p>Min. active spline length⁽²⁾: 55 mm [2.17 in]</p>

Installation Drawings

Code	Description	Maximum Torque Rating	Drawing
A	Splined shaft SAE J744, 2 in, 15T, 8/16 DP	2422 N·m [21437 lbf·in]	<p>7.8 ± 0.8</p> <p>Mating coupling must not protrude beyond this point</p> <p>Paint free</p> <p>Spline data Number of teeth: 15 Pitch friction : 8/16 Pressure angle : 30° pitch : Ø 47.625 Type of fit : Fillet root side Per : ANSI B92.1-1996, Class 5</p> <p>12 ± 2 5.2 ± 0.5</p> <p>Ø40.7 ± 0.1</p> <p>Ø50.8 - 0.127 Ø126 ± 0.1</p> <p>36 ± 2 FULL THD 44 ± 1 66 - 0.5 (87.7)</p> <p>Mounting flange Flange 165-4 Per SAE J744</p> <p>5/8-11 UNC-2B THD¹⁾ Ø17 ± 0.2 Ø23 ± 0.2</p> <p>Min. active spline length⁽²⁾: 66 mm [2.60 in]</p> <p>P400427</p>

Installation Drawings

Code	Description	Maximum Torque Rating	Drawing
P	Straight keyed shaft, DIN 6885, AS16x10x100	2195 N•m [19427 lbf•in]	<p style="text-align: right;">P400428</p>
K	SAE J744 (D/E) 3in straight keyed shaft, 0.4375x3.000 in	1787 N•m [15816 lbf•in]	

- 1) Center bore according to DIN 332 (thread according to DIN 13)
- 2) Minimum active spline length for the specified torque ratings

Installation Drawings

Aux mounting flange

Size 193: Option NN (No Coupling)

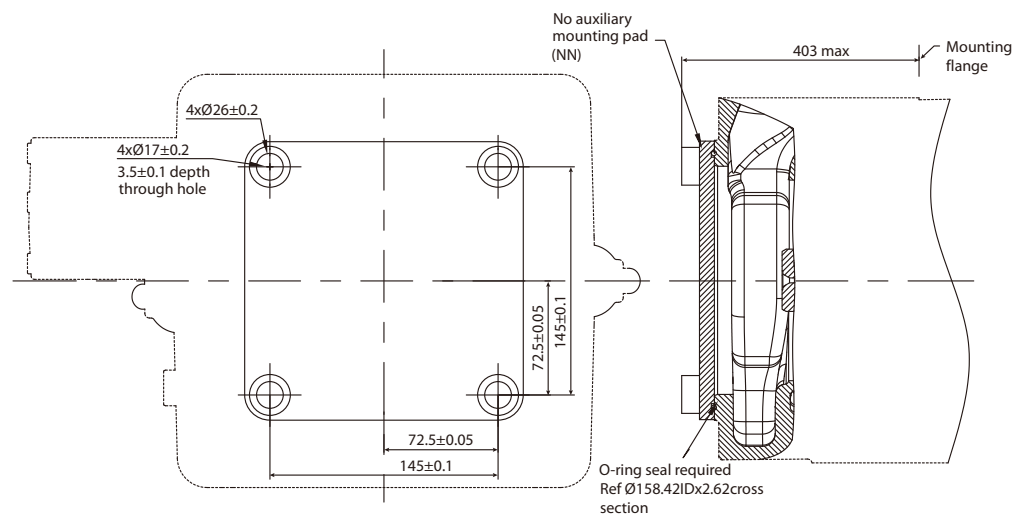

P400274

Specifications

Option	Coupling
NN	No coupling

Size 193: Option A1 (SAE-A, 9 teeth)

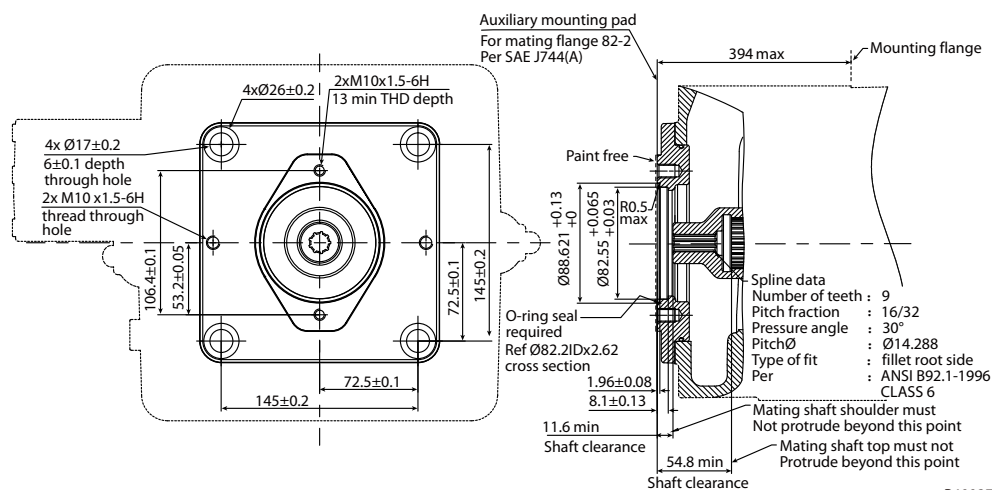

P400275

Specifications

Option	Coupling	Max torque
A1	5/8 in, 9T, 16/32 DP	205 N·m [1814.40 lbf·in]

Installation Drawings

Size 193: Option A3 (SAE-A, 13 teeth)

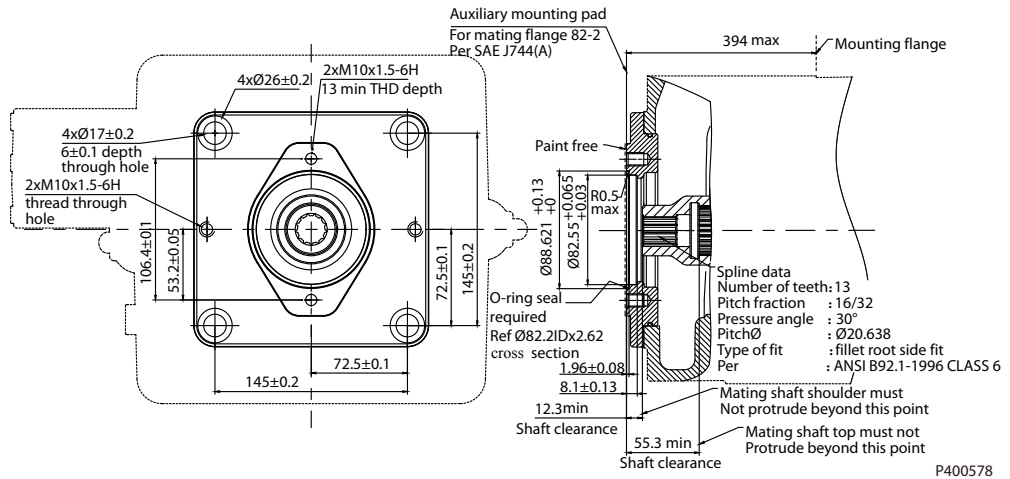

Specifications

Option	Coupling	Max torque
A3	7/8 in, 13T, 16/32 DP	619 N·m [5478.61 lbf·in]

Size 193: Option B1 (SAE-B, 13 teeth)

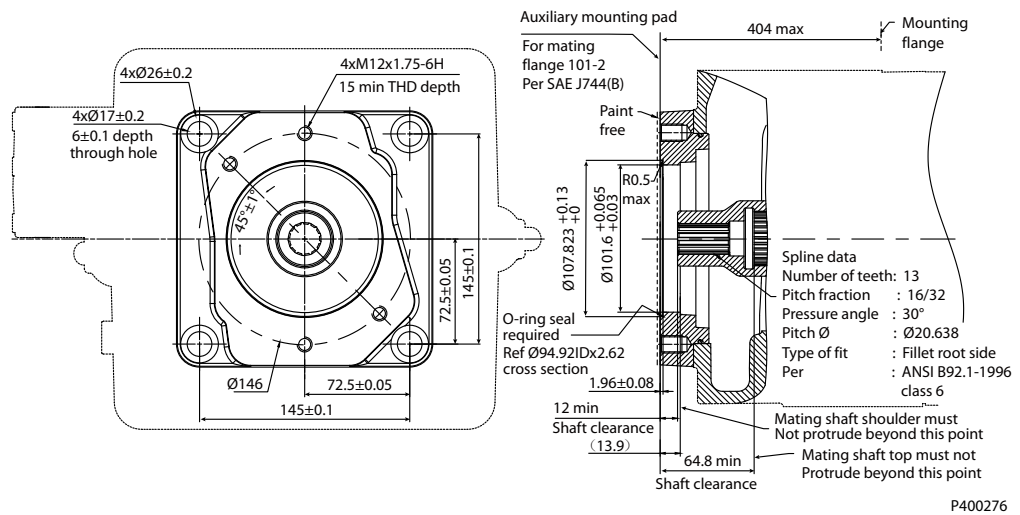

Specifications

Option	Coupling	Max torque
B1	7/8 in, 13T, 16/32 DP	411 N·m [3637.66 lbf·in]

Installation Drawings

Size 193: Option C5 (SAE-C, 14 teeth)

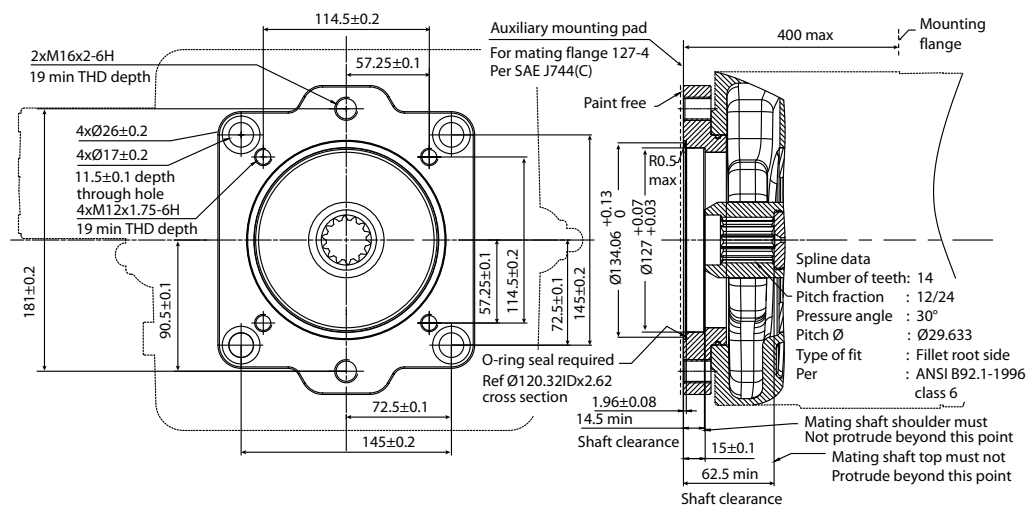

P400277

Specifications

Option	Coupling	Max torque
C5	1 1/4 in, 14T, 12/24 DP	1289 N·m [11408.61 lbf·in]

Size 193: Option C9 (SAE-C, 13 teeth)

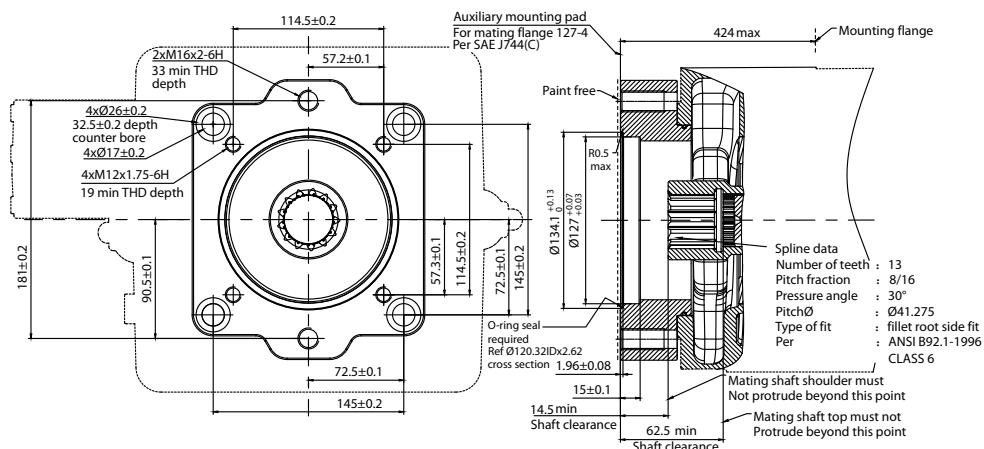

P400579

Specifications

Option	Coupling	Max torque
C9	1 3/4 in, 13T, 8/16 DP	1790 N·m [15842.83 lbf·in]

Installation Drawings

Size 193: Option D2 (SAE-D, 13 teeth)

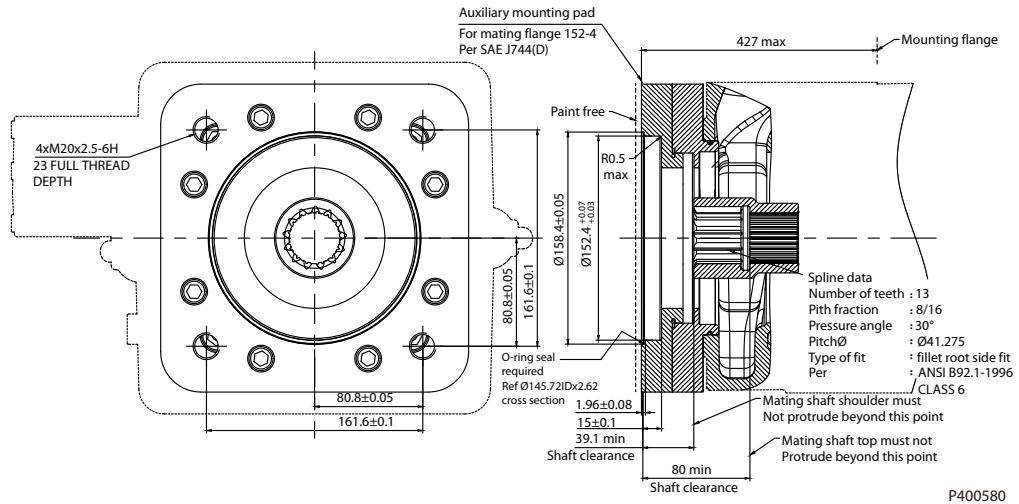

Specifications

Option	Coupling	Max torque
D2	1 3/4 in, 13T, 8/16 DP	1630 N·m [14426.72 lbf·in]

Size 193: Option D5 (SAE-D, 24 teeth)

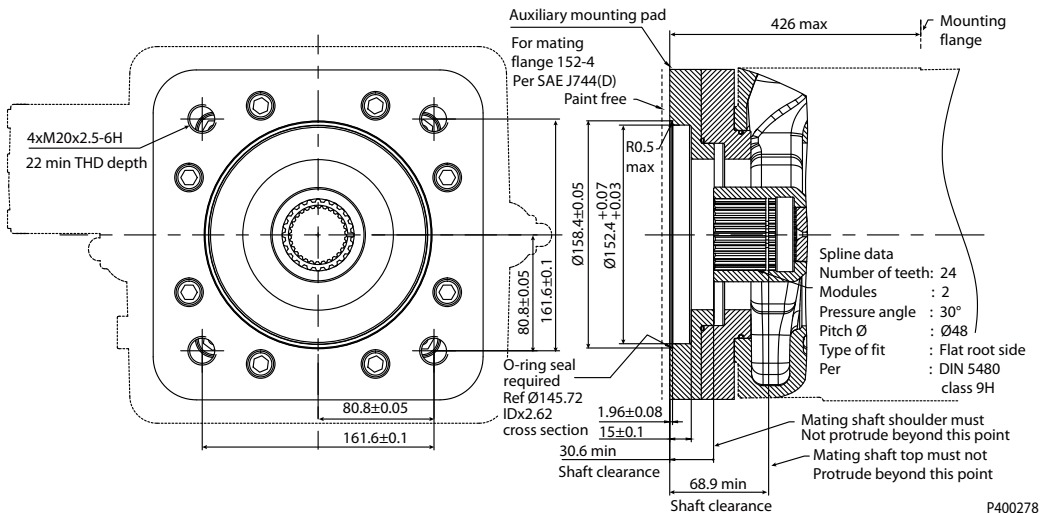

Specifications

Option	Coupling	Max torque
D5	N50 x 2 x 30 x 24 x 9H	1790 N·m [15842.83 lbf·in]

Installation Drawings

Size 193: Option E2 (SAE-E, 24 teeth)

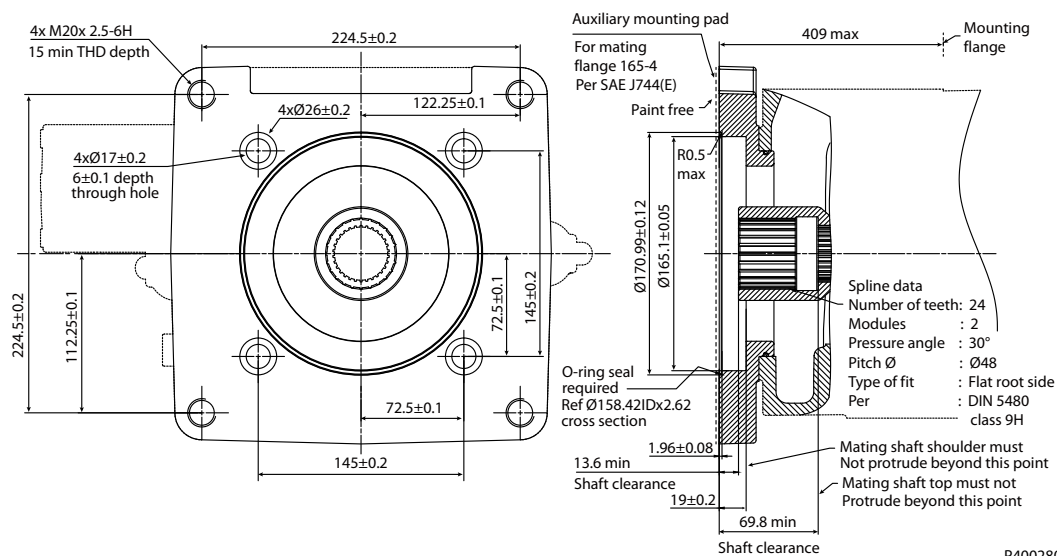

P400280

Specifications

Option	Coupling	Max torque
E2	N50 x 2 x 30 x 24 x 9H	1790 N·m [15842.83 lbf·in]

Before finalizing your design, please request a certified drawing.

Installation Drawings

Size 260

Dimensions (mm) and port descriptions

Size 260: TPE2 w/ Charge Pump

Control : TPE2

Power Control (T) + Pressure Compensated Control (P) + Electric Displacement Control (E2)

Auxiliary flange : B1

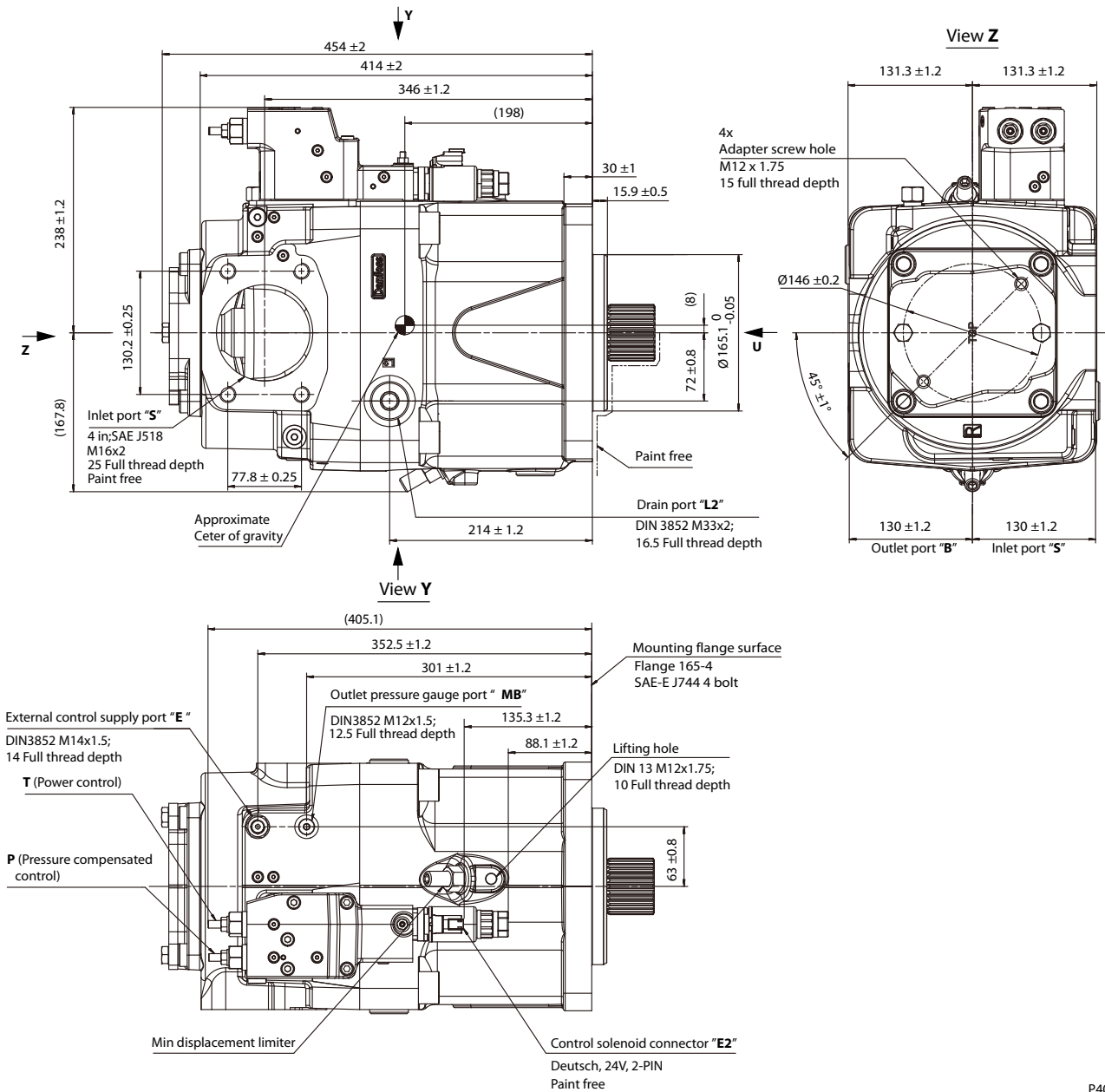

Before finalizing your design, please request a certified drawing.

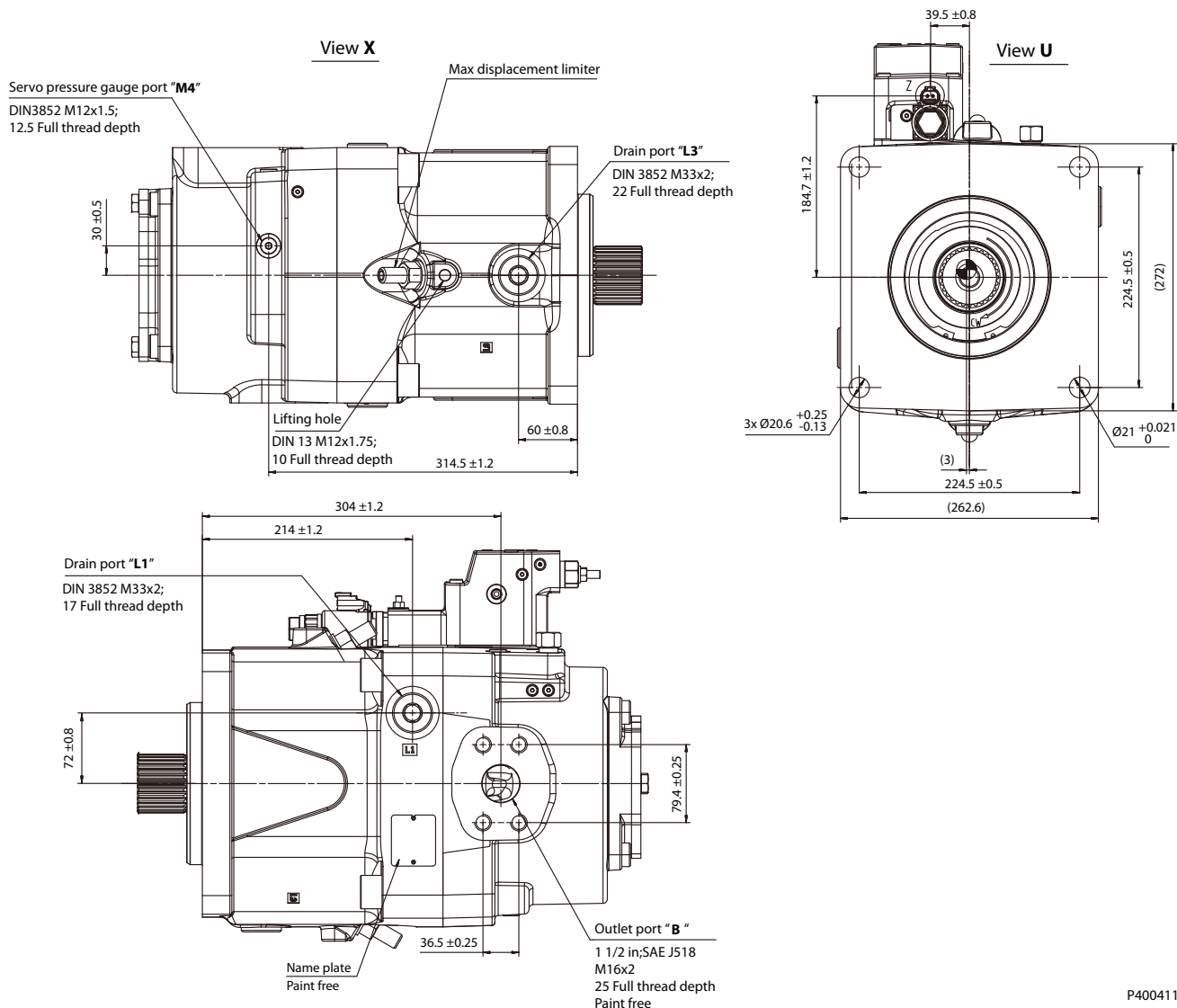
Installation Drawings

P400411

Before finalizing your design, please request a certified drawing.

Port Descriptions

Ports	Description	Standard	Size ¹⁾	Max. pressure (bar [psi])	State ²⁾
B	Outlet port, Fixing thread	SAE J518, DIN13	1 1/2 in, M16 x 2; 25 deep	400 [5802]	O
S	Suction port, Fixing thread	SAE J518, DIN13	4 in, M16 x 2; 25 deep	2 [29]	O
L₁, L₂, L₃	Drain port	DIN 3852	M33 x 2; 17, 16.5, 22 deep	2 [29]	X ³⁾
M₄	Measurement point, servo-piston chamber	DIN 3852	M12 x 1.5; 12.5 deep	400 [5802]	X
M_B	Measurement point, outlet port	DIN 3852	M12 x 1.5; 12.5 deep	400 [5802]	X
E	External control port	DIN 3852	M14 x 1.5; 14 deep	200 [2901]	X ⁴⁾

¹⁾ For required torque, please refer to [DIP tightening torque](#) on page 79

²⁾ O = Open, must be connected (closed by plastic plug on delivery) / X = Closed (closed by metal plug on delivery)

³⁾ Depending on installation position, one of L₁, L₂ and L₃ must be connected (please refer to Installation Notes).

⁴⁾ If E port is not used, remove the shuttle valve and lock port by seal plug.

Installation Drawings

Size 260: TPSN w/ Charge Pump

Control : TPSN

Power Control (T) + Pressure Compensated Control (P) + Load Sensing Control (S)

Auxiliary flange : NN

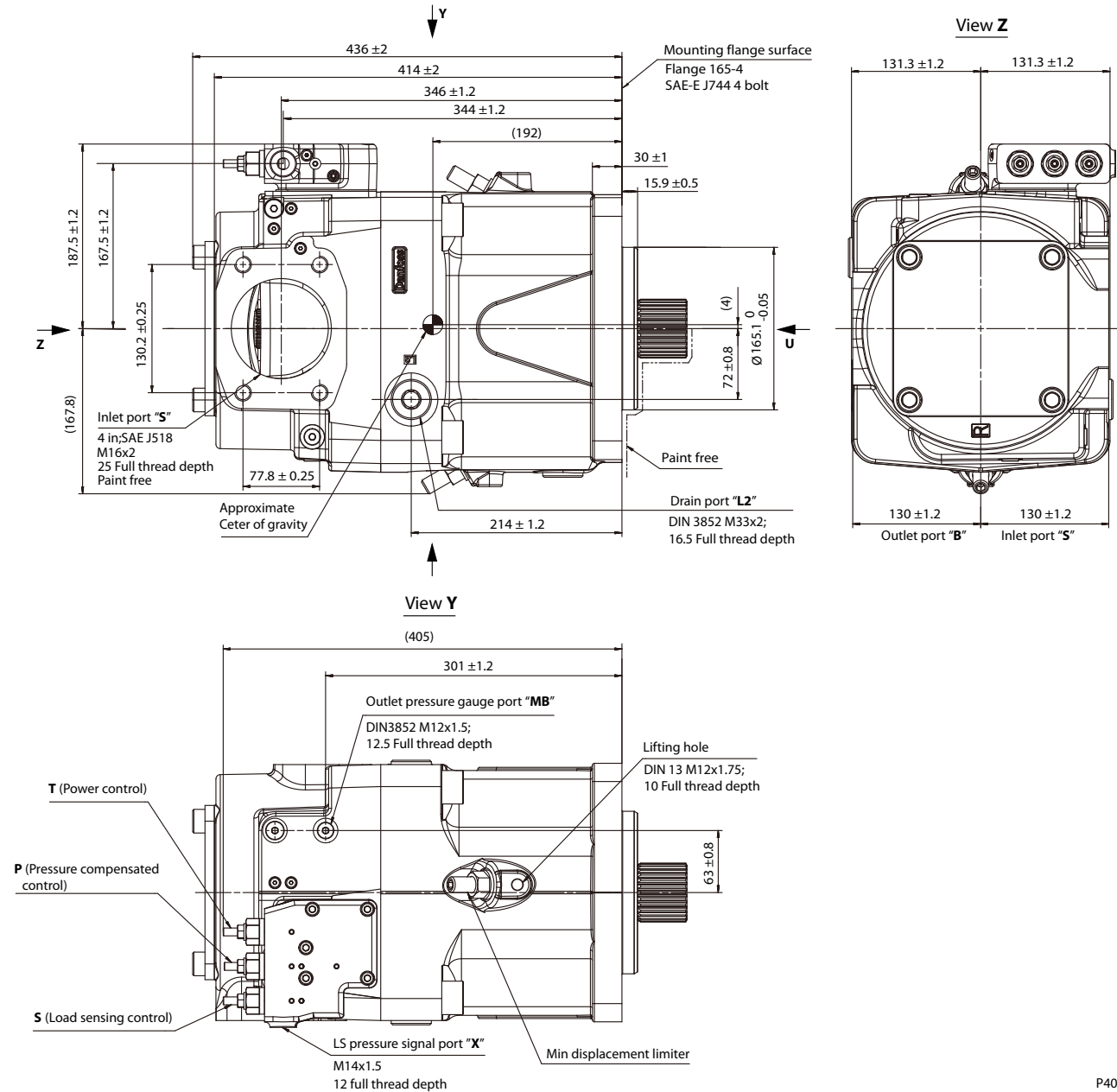

P400412

Before finalizing your design, please request a certified drawing.

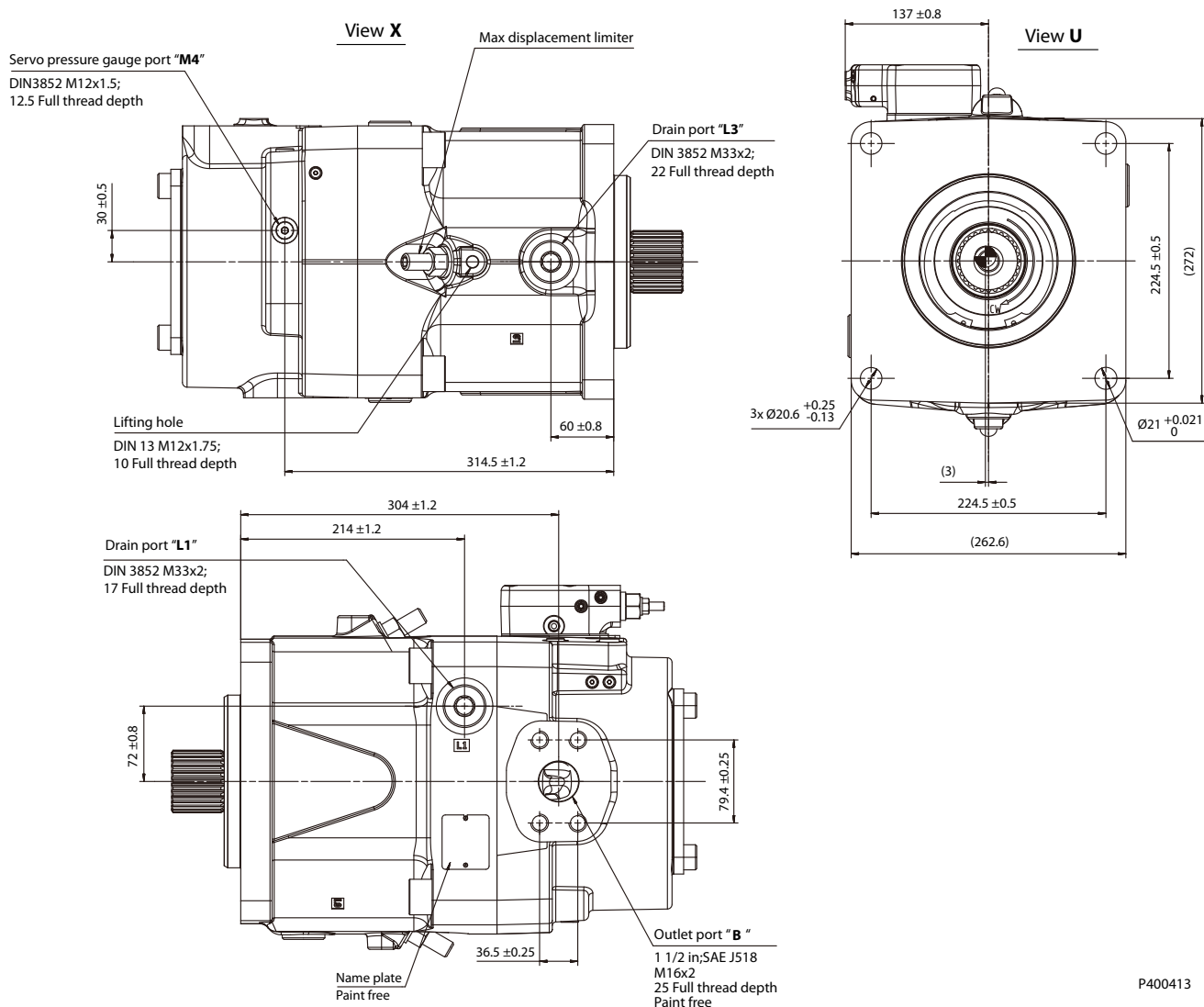
Installation Drawings

P400413

Before finalizing your design, please request a certified drawing.

Port Descriptions

Ports	Description	Standard	Size ¹⁾	Max. pressure (bar [psi])	State ²⁾
B	Outlet port, Fixing thread	SAE J518, DIN13	1 1/2 in, M16 x 2; 25 deep	400 [5802]	O
S	Suction port, Fixing thread	SAE J518, DIN13	4 in, M16 x 2; 25 deep	2 [29]	O
L₁, L₂, L₃	Drain port	DIN 3852	M33 x 2; 17, 16.5, 22 deep	2 [29]	X ³⁾
M₄	Measurement point, servo-piston chamber	DIN 3852	M12 x 1.5; 12.5 deep	400 [5802]	X
M_B	Measurement point, outlet port	DIN 3852	M12 x 1.5; 12.5 deep	400 [5802]	X
X	LS port	DIN 3852	M14 x 1.5; 12 deep	400 [5802]	O

¹⁾ For required torque, please refer to *D1P tightening torque* on page 79.

²⁾ O = Open, must be connected (closed by plastic plug on delivery) / X = Closed (closed by metal plug on delivery).

³⁾ Depending on installation position, one of L₁, L₂ and L₃ must be connected (please refer to Installation Notes).

Installation Drawings

Input shaft

D1P 260 shaft specifications

Code	Description	Maximum Torque Rating	Drawing
T	Splined shaft DIN 5480, W60 x 2 x 30 x 28 x 9g	5432 N·m [48077 lbf·in]	<p>Mating coupling must not Protrude beyond this point</p> <p>Paint free</p> <p>Spline data Number of teeth: 28 Module : 2 Pressure angle : 30° Pitch Ø : Ø56 Type of fit : Flat root side Per : DIN 5480 class 9g</p> <p>Ø 54.4 ± 0.1</p> <p>8 ± 0.8</p> <p>15 ± 2</p> <p>6 ± 0.5</p> <p>42 ± 2 FULL THD</p> <p>47 ± 0.5</p> <p>52 ± 1 (66.0)</p> <p>Ø 21 ± 0.2</p> <p>Ø 28 ± 0.2</p> <p>Ø 59.6⁰_{-0.19}</p> <p>Ø 131 ± 0.1</p> <p>M20 x 2.5-6H THD⁽¹⁾</p> <p>Mounting flange Flange 165-4 Per SAE J744</p> <p>Min. active spline length⁽²⁾: 47 mm [1.85 in]</p> <p>P400414</p>
S	Splined shaft SAE J744, 1 3/4 in. 13T, 8/16 DP	1535 N·m [13586 lbf·in]	<p>Mating coupling must not Protrude beyond this point</p> <p>Paint free</p> <p>Spline data Number of teeth : 13 Pitch friction : 8/16 Pressure angle : 30° pitch : Ø 41.275 Type of fit : Fillet root side Per : ANSI B92.1-1996, Class 5</p> <p>Ø 34.5 ± 0.1</p> <p>8 ± 0.8</p> <p>12 ± 2</p> <p>5.2 ± 0.5</p> <p>36 ± 2 Full THD</p> <p>44 ± 1</p> <p>Ø 17 ± 0.2</p> <p>Ø 23 ± 0.2</p> <p>Ø 44.45⁰_{-0.127}</p> <p>Ø 131 ± 0.1</p> <p>5/8-11 UNC-2B THD</p> <p>Mounting flange Flange 165-4 Per SAE J744</p> <p>Min. active spline length⁽²⁾: 55 mm [2.17 in]</p> <p>P400513</p>

Installation Drawings

Code	Description	Maximum Torque Rating	Drawing
A	Splined shaft SAE J744, 2 1/4 in. 17T, 8/16 DP	3621 N·m [32049 lbf·in]	<p>8 ± 0.8</p> <p>Mating coupling must not protrude beyond this point</p> <p>Paint free</p> <p>Spline data Number of teeth : 17 Pitch friction : 8/16 Pressure angle : 30° pitch : Ø 53.975 Type of fit : Fillet root side Per : ANSI B92.1-1996, Class 5</p> <p>15 ± 2</p> <p>6.1 ± 0.5</p> <p>Ø47 ±0.1</p> <p>Ø57.15 ±0.127</p> <p>Ø131 ±0.1</p> <p>42 ± 2 Full THD 55 ± 1</p> <p>Ø21 ±0.2 Ø28 ±0.2</p> <p>0 66 -0.5 (88)</p> <p>3/4 -10 UNC-2B THD</p> <p>Mounting flange Flange 165-4 Per SAE J744</p> <p>P400514</p> <p>Min. active spline length⁽²⁾: 66 mm [2.60 in]</p>

Installation Drawings

Code	Description	Maximum Torque Rating	Drawing
P	Straight keyed shaft, DIN 6885, AS18x11x100	2571 N·m [22755 lbf·in]	
K	SAE J744 (D/E) Ø1.75in straight keyed shaft, 0.4375 x 3.000in key	1787 N·m [15816 lbf·in]	

- 1) Center bore according to DIN 332 (thread according to DIN 13)
- 2) Minimum active spline length for the specified torque ratings

Installation Drawings

Aux mounting flange

Size 260: Option A1 (SAE-A, 9 teeth)

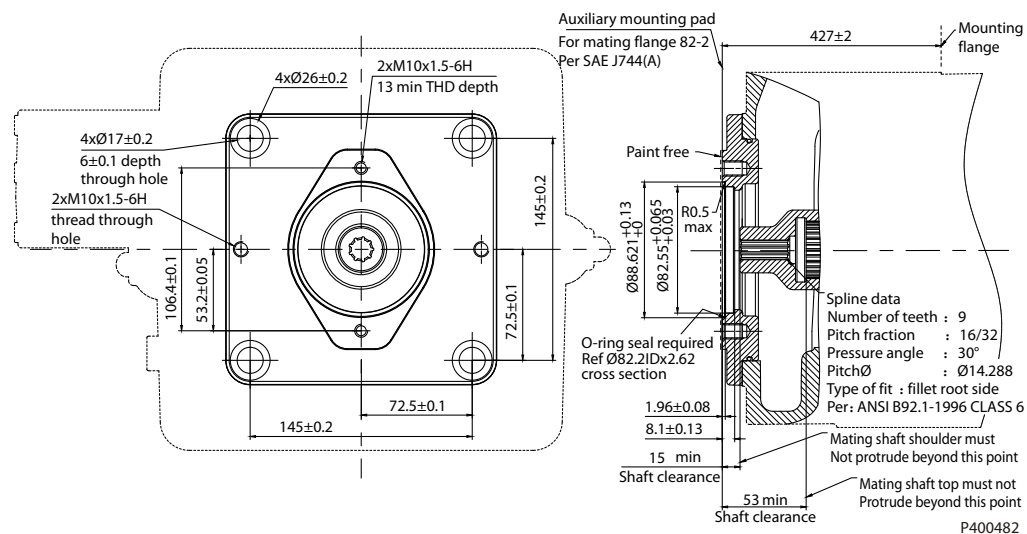

Specifications

Option	Coupling	Max torque
A1	5/8 in, 9T, 16/32 DP	205 N·m [1814.40 lbf·in]

Size 260: Option A3 (SAE-A, 13 teeth)

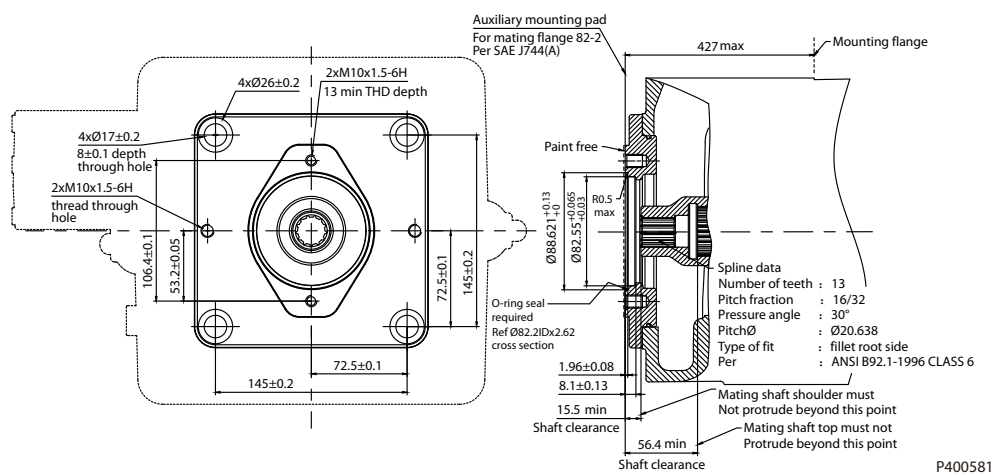

Specifications

Option	Coupling	Max torque
A3	7/8 in, 13T, 16/32 DP	619 N·m [5478.61 lbf·in]

Installation Drawings

Size 260: Option B1 (SAE-B, 13 teeth)

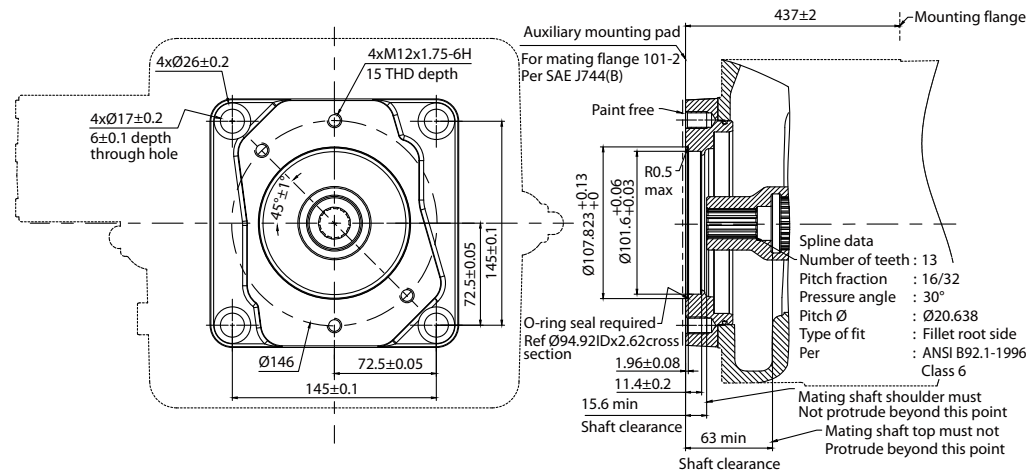

P400415

Specifications

Option	Coupling	Max torque
B1	7/8 in, 13T, 16/32 DP	411 N·m [3637.66 lbf·in]

Size 260: Option C5 (SAE-C, 14 teeth)

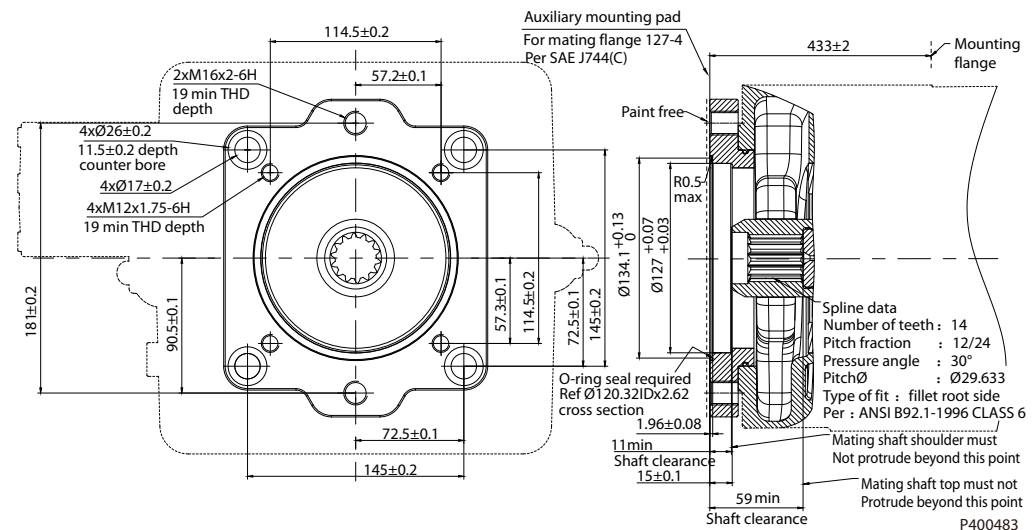

P400483

Specifications

Option	Coupling	Max torque
C5	1 1/4 in, 14T, 12/24 DP	1638 N·m [14497.52 lbf·in]

Installation Drawings

Size 260: Option C9 (SAE-C, 13 teeth)

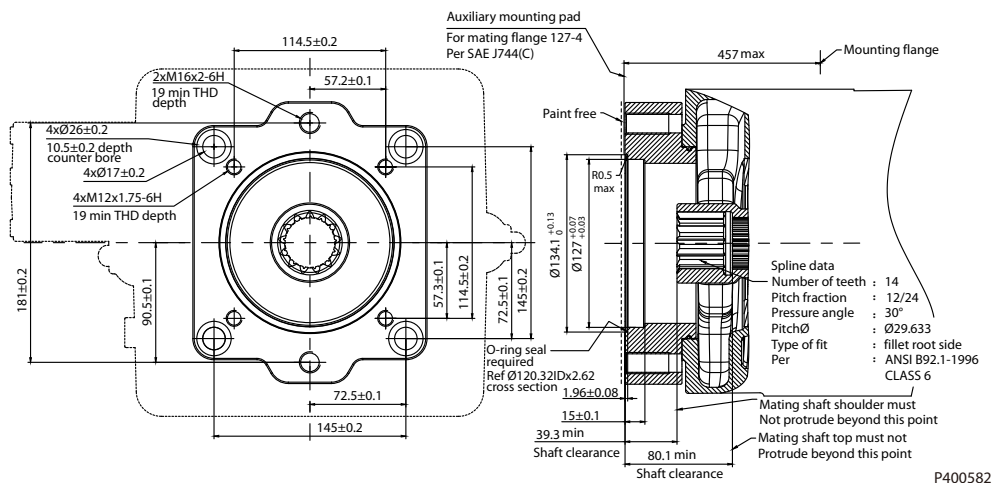

Specifications

Option	Coupling	Max torque
C9	1 3/4 in, 13T, 8/16 DP	1891 N·m [16736.76 lbf·in]

Size 260: Option D2 (SAE-D, 13 teeth)

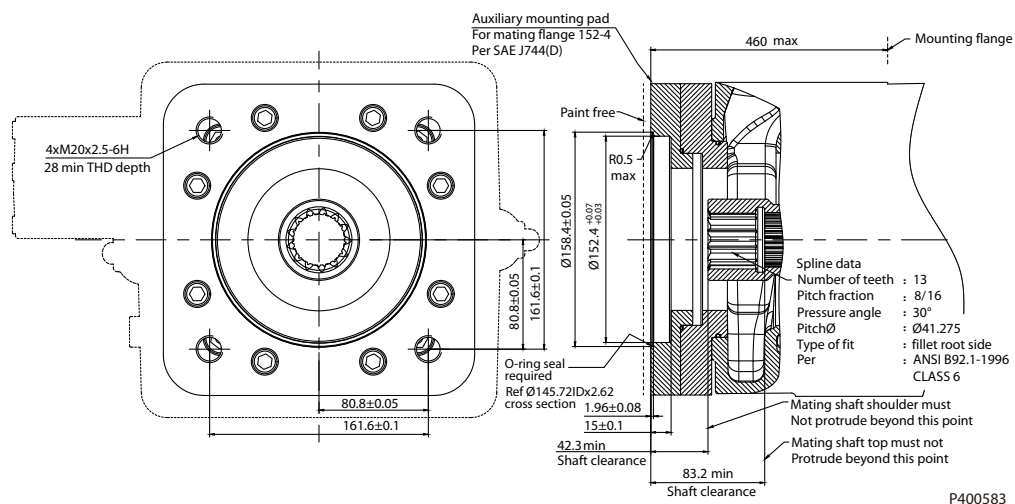

Specifications

Option	Coupling	Max torque
D2	1 3/4 in, 13T, 8/16 DP	1819 N·m [16099.50 lbf·in]

Installation Drawings

Size 260: Option D5 (SAE-D, 24 teeth)

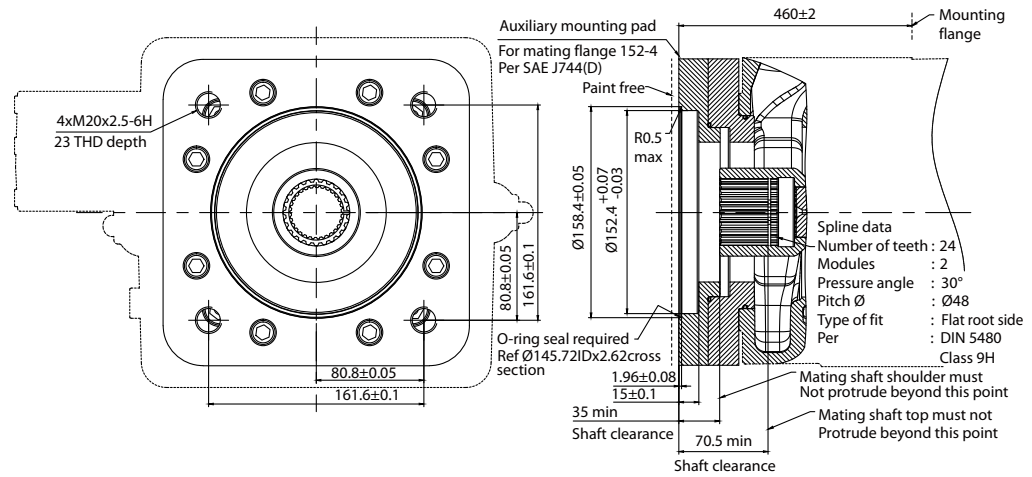

P400416

Specifications

Option	Coupling	Max torque
D5	N50 x 2 x 30 x 24 x 9H	1936 N·m [17135.04 lbf·in]

Size 260: Option E2 (SAE-E, 24 teeth)

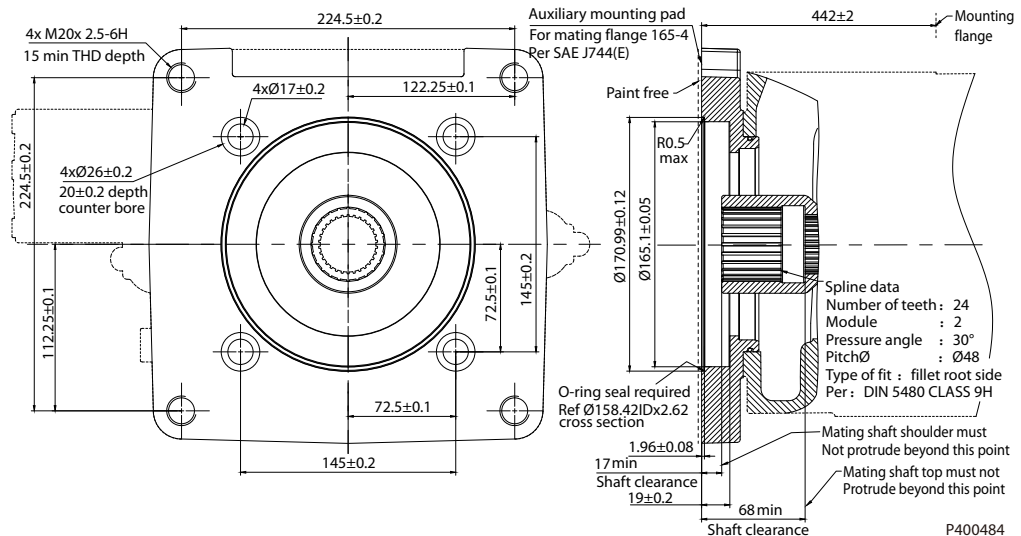

P400484

Specifications

Option	Coupling	Max torque
E2	N50 x 2 x 30 x 24 x 9H	1936 N·m [17135.04 lbf·in]

Installation Drawings

Size 260: Option E3 (SAE-E, 28 teeth)

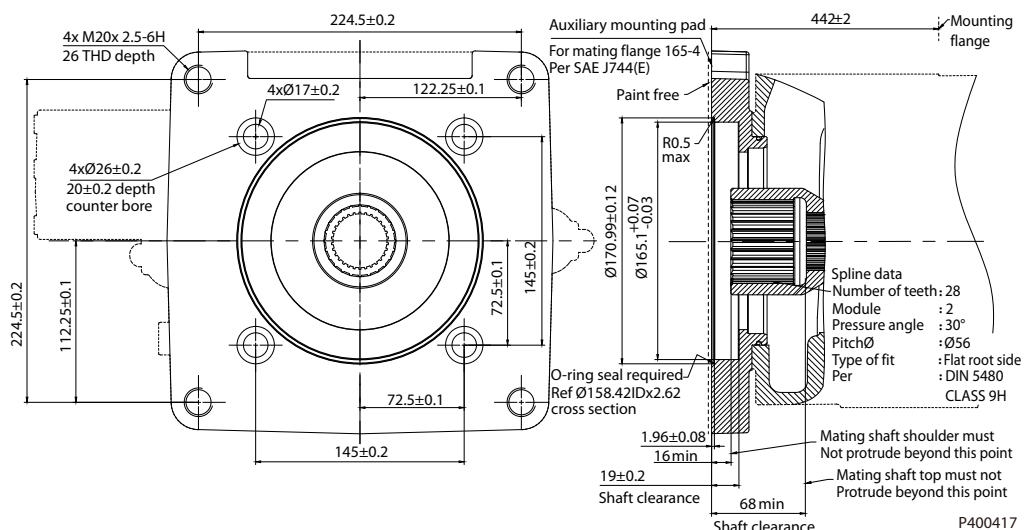

Specifications

Option	Coupling	Max torque
E3	N60 x 2 x 30 x 28 x 9H	1936 N·m [17135.04 lbf·in]

Before finalizing your design, please request a certified drawing.

Additional Information
D1P tandem with Danfoss pumps

1st Pump			2nd Pump						
D1P (OC)			D1P (OC)	S45 (OC)	S90 (CC)	H1P (CC)	S42 (CC)	S40 (CC)	Gear Pump
Through Drive									
Flange	Coupling	Code	Size (shaft)	Size (shaft)	Size (shaft)	Size (shaft)	Size (shaft)	Size (shaft)	Size (shaft)
82-2 A	5/8 in 9T	A1							4 ~ 45 (SA, SM, SE)
		A3							7 ~ 45 (SH)
101-2 B	7/8 in 13T	B1		25, 30, 38, 45 (C2)		45, 53 (G4)	28, 32, 41, 51 (C)	25, 35, 44, 46 (A)	7 ~ 90 (SA, SL, SH)
127-2&4 C	1 1/4 in 14T	C5		45, 51, 60, 65, 74, 75, 90, 100, 130, 147 (S1)	55, 75, 100 (S1)	60, 68, 69, 78, 89, 100 (G1)			22 ~ 200 (RA, RD, SO)
	1 3/4 in 13T	C9		100, 130, 147 (S4)					
152-4 D	W50	D5	130/145 (T)						
	1 3/4 in 13T	D2			130 (F1)	115, 130, 147, 165 (G3)			
165-4 E	W50	E2	193 (T)						
165-4 E	W60	E3	260 (T)						

D1P tandem pump torque
Maximum torque rating and tandem pump torque

D1 Pump Displacement		130/145	193	260
Torque at Vg max and $\Delta p = 350$ bar		724/808 N•m [6407.94/7151.40 lbf•in]	1075 N•m [9514.55 lbf•in]	1448 N•m [12815.88 lbf•in]
Max torque rating of input shaft	T	3100 N•m [27437 lbf•in]	3100 N•m [27437 lbf•in]	5432 N•m [48077 lbf•in]
	S	1528 N•m [13524 lbf•in]	1536 N•m [13595 lbf•in]	1535 N•m [13586 lbf•in]
	A	-	2422 N•m [21437 lbf•in]	3621 N•m [32049 lbf•in]
	P	1411 N•m [12488 lbf•in]	2195 N•m [19427 lbf•in]	2571 N•m [22755 lbf•in]
	K	1787 N•m [15816 lbf•in]	1787 N•m [15816 lbf•in]	1787 N•m [15816 lbf•in]

Additional Information
Maximum torque rating and tandem pump torque (continued)

D1 Pump Displacement		130/145	193	260
Max torque rating of different aux mounting flange options	A1	205 N·m [1814.40 lbf·in]	205 N·m [1814.40 lbf·in]	205 N·m [1814.40 lbf·in]
	A3	-	619 N·m [5478.61 lbf·in]	619 N·m [5478.61 lbf·in]
	B1	411 N·m [3637.66 lbf·in]	411 N·m [3637.66 lbf·in]	411 N·m [3637.66 lbf·in]
	C5	1164 N·m [10302.27 lbf·in]	1289 N·m [11408.61 lbf·in]	1638 N·m [14497.52 lbf·in]
	C9	-	1790 N·m [15842.83 lbf·in]	1891 N·m [16736.76 lbf·in]
	D2	1130 N·m [10001.35 lbf·in]	1630 N·m [14426.72 lbf·in]	819 N·m [16099.51 lbf·in]
	D5	1164 N·m [10302.27 lbf·in]	1790 N·m [15842.83 lbf·in]	1936 N·m [17135.04 lbf·in]
	E2	-	1790 N·m [15842.83 lbf·in]	1936 N·m [17135.04 lbf·in]
	E3	-	-	1936 N·m [17135.04 lbf·in]

D1P tightening torque

The following tightening torques apply:

Fittings Observe the manufacturer's instruction regarding the tightening torques of the fittings used.

Fixing screws For fixing screws according to DIN 13, we recommend checking the tightening torque individually according to VDI 2230.

Locking screws For the metal locking screws supplied with the D1 pump, the required torques are as indicated in the table below:

Thread size	Standard	Required torque	Wrench size
M12 x 1.5	DIN 3852	25 N·m [221.27 lbf·in]	6 mm
M14 x 1.5		34 N·m [300.93 lbf·in]	6 mm
M26 x 1.5		60 N·m [531.05 lbf·in]	12 mm
M33 x 2		225 N·m [1991.42 lbf·in]	17 mm

Installation Notes

D1P below-reservoir (standard)

Recommended arrangements : 1 and 2.

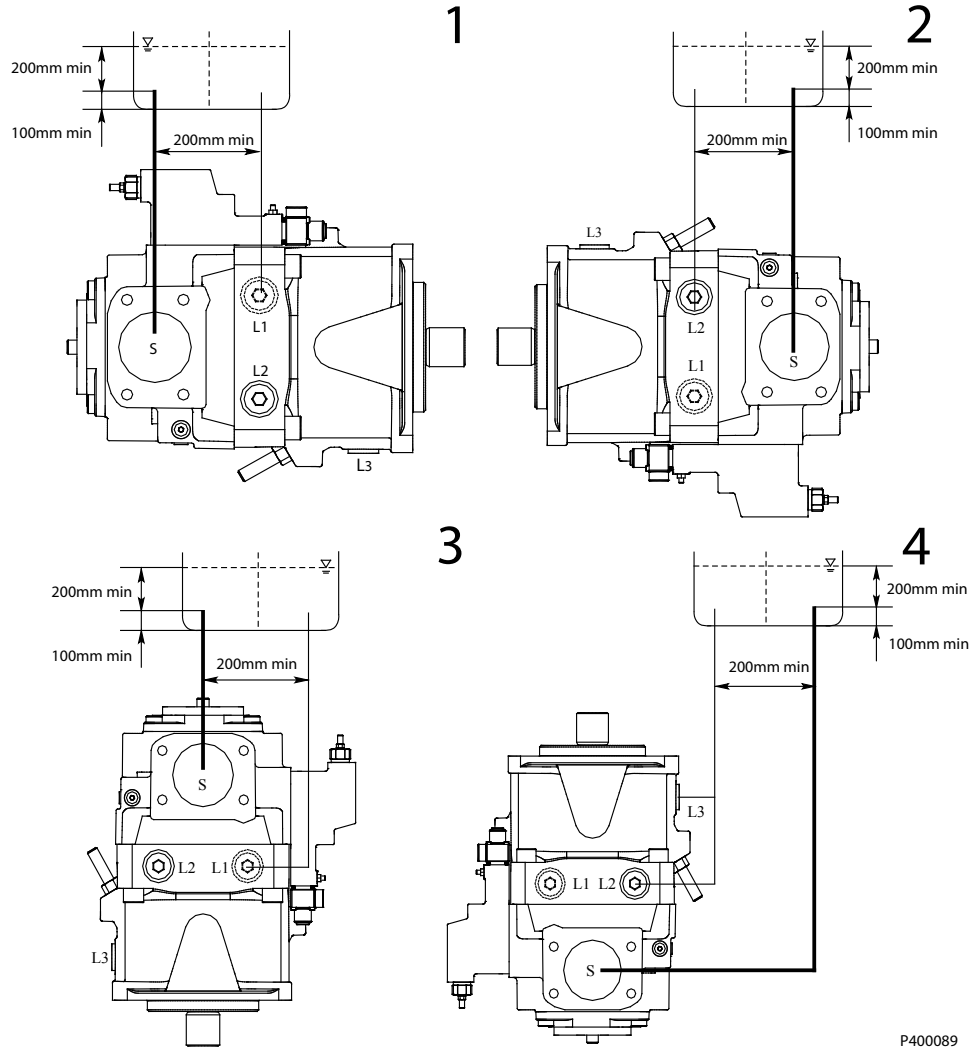

P400089

Fill pump case with clean oil before start

Suction (absolute) : P min = 0.6 bar with charge pump (0.8 bar without charge pump), P max = 2 bar. Do not restrict suction line

Drain (absolute) : P max = 2 bar. Do not restrict drain line, do not combine drain line

Arrangements	Air Bleeding	Filling
1	L1	S + L1
2	L3	S + L2
3	L1 / L2	S + L1 / L2
4	L3	S + L1 / L2

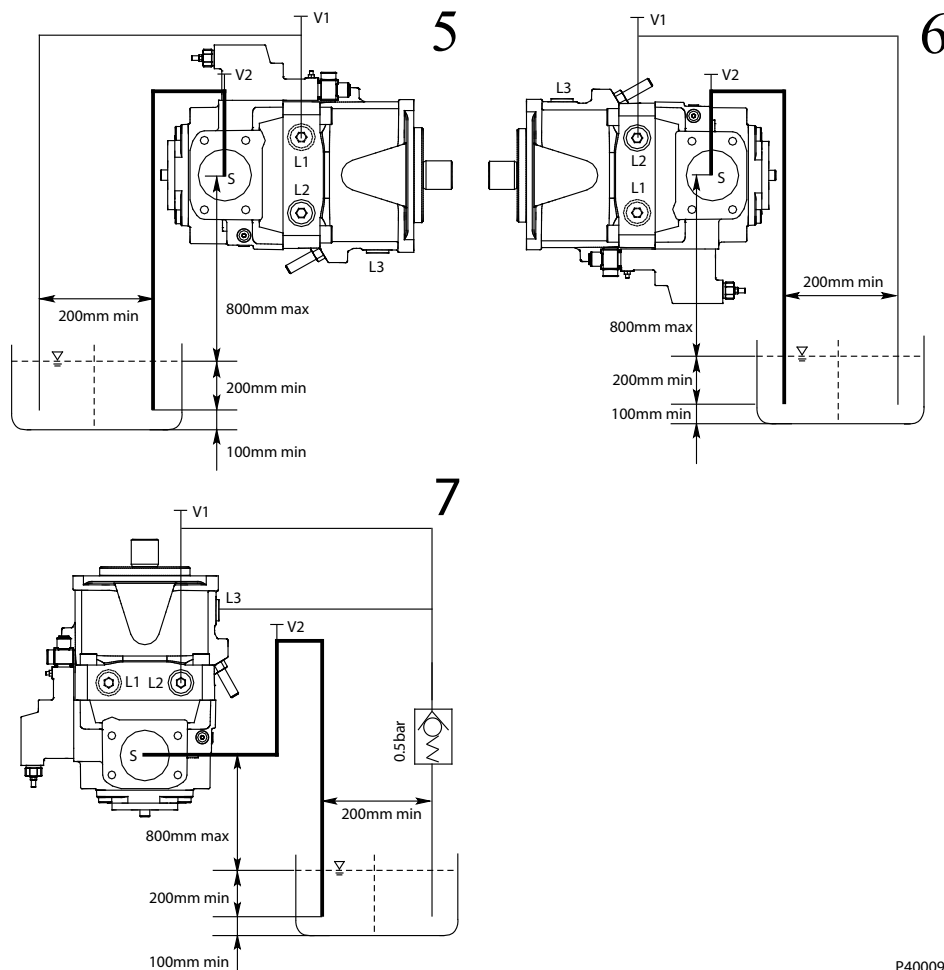
Installation Notes
D1P above-reservoir

P400090

Fill pump case with clean oil before start

Suction (absolute) : P min = 0.6 bar with charge pump (0.8 bar without charge pump), P max = 2 bar. Do not restrict suction line

Drain (absolute) : P max = 2 bar. Do not restrict drain line, do not combine drain line

Arrangements	Air Bleeding	Filling
5	V1 + V2	V2 (S) + V1 (L1)
6	L3 + V2	V2 (S) + V1 (L2)
7	V1 + V2	V2 (S) + V1 (L1 / L2)

Caution! Installation hazards!

Failure to adhere to the installation notes may result in shortened product life.

The maximum allowable suction height is 0.8m. The allowable suction height is derived from the total pressure loss.

The D1 pump with charge pump is not designed for above-Reservoir installation.

For control options with pressure controllers, proportional displacement control, the minimum displacement setting must be $V_g \geq 5\% V_g \text{ max}$.

Recommendation for arrangement 7 (shaft upwards): A check valve in the case drain line (cracking pressure 0.5 bar) can prevent draining of the case interior.

Installation Notes

D1P reservoir installation

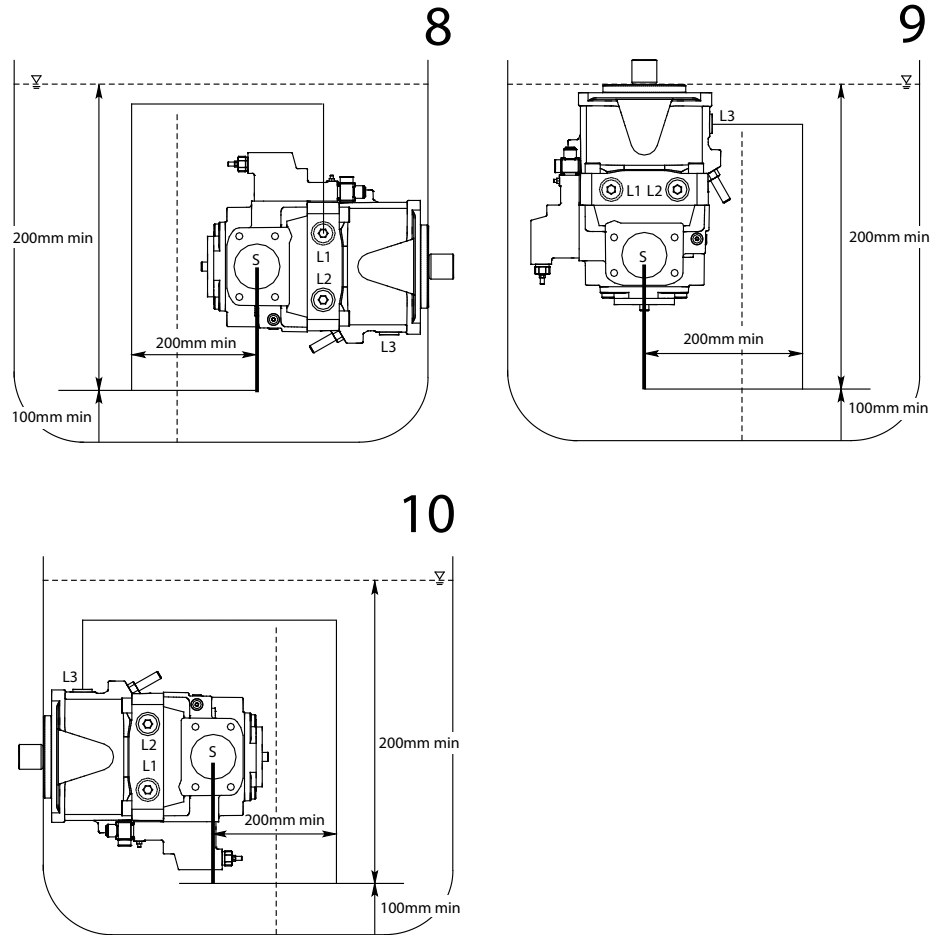

P400091

Fill pump case with clean oil before start

Suction (absolute) : P min = 0.6 bar with charge pump (0.8 bar without charge pump), P max = 2 bar. Do not restrict suction line

Drain (absolute) : P max = 2 bar. Do not restrict drain line, do not combine drain line

Arrangements	Air Bleeding	Filling
8	L1	Automatically via all open L1, L2, L3 and S ports through position below the hydraulic fluid level.
9	L3	
10	L3	

- It is recommended to fit a pipe to the suction port S and fitting a pipe to case drain port L1, L2 or L3 (See arrangements), the other case drain ports must be plugged in this situation. The pump should be filled before fitting the pipe and filling the tank with hydraulic fluid.
- It is only permissible to install a pump with solenoids (E.g. a pump with electric displacement control) at tank-level, if used hydraulic fluids are based on mineral oil and the oil temperature in the tank does not exceed 80° C.

Displacement Limiter

D1P displacement limiter

Series D1 pumps feature maximum and minimum displacement limiters, which limit displacement mechanically.

Maximum Displacement Limiter

Frame	Setting range	Displacement change per turn
130	72 cm ³ – 130 cm ³	11 cm ³ /rev
145	72 cm ³ – 145 cm ³	11 cm ³ /rev
193	0 cm ³ – 193 cm ³	16 cm ³ /rev
260	56 cm ³ – 260 cm ³	19 cm ³ /rev

Minimum Displacement Limiter

Frame	Setting range	Displacement change per turn
130	0 cm ³ – 124 cm ³	9 cm ³ /rev
145	0 cm ³ – 124 cm ³	9 cm ³ /rev
193	0 cm ³ – 193 cm ³	15 cm ³ /rev
260	0 cm ³ – 260 cm ³	18 cm ³ /rev

Displacement Limiter Cross-Section View

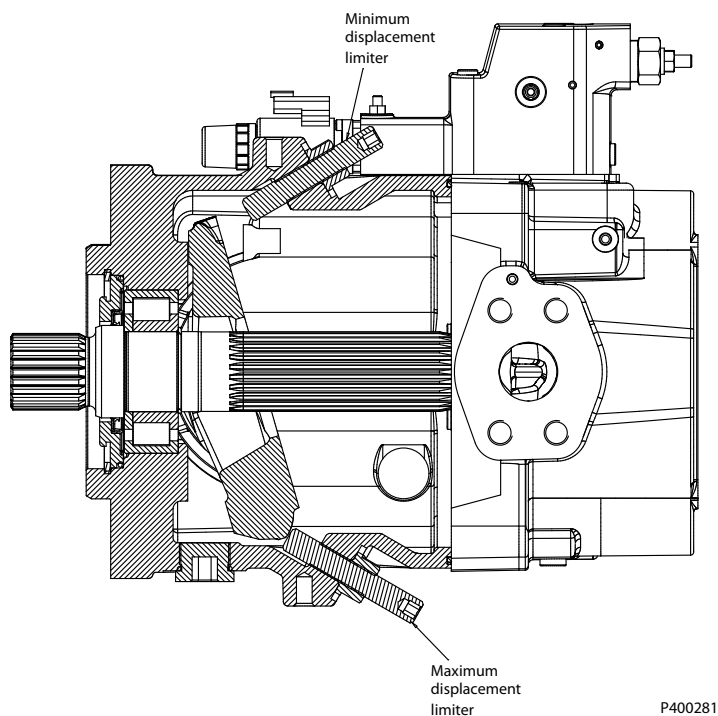

P400281

Products we offer:

- DCV directional control valves
- Electric converters
- Electric machines
- Electric motors
- Gear motors
- Gear pumps
- Hydrostatic motors
- Hydrostatic pumps
- Orbital motors
- PLUS+1® controllers
- PLUS+1® displays
- PLUS+1® joysticks and pedals
- PLUS+1® operator interfaces
- PLUS+1® sensors
- PLUS+1® software
- PLUS+1® software services, support and training
- Position controls and sensors
- PVG proportional valves
- Steering components and systems
- Telematics

Danfoss Power Solutions is a global manufacturer and supplier of high-quality hydraulic and electric components. We specialize in providing state-of-the-art technology and solutions that excel in the harsh operating conditions of the mobile off-highway market as well as the marine sector. Building on our extensive applications expertise, we work closely with you to ensure exceptional performance for a broad range of applications. We help you and other customers around the world speed up system development, reduce costs and bring vehicles and vessels to market faster.

Danfoss Power Solutions – your strongest partner in mobile hydraulics and mobile electrification.

Go to www.danfoss.com for further product information.

We offer you expert worldwide support for ensuring the best possible solutions for outstanding performance. And with an extensive network of Global Service Partners, we also provide you with comprehensive global service for all of our components.

Hydro-Gear

www.hydro-gear.com

Daikin-Sauer-Danfoss

www.daikin-sauer-danfoss.com

Local address:

**Danfoss
Power Solutions (US) Company**
2800 East 13th Street
Ames, IA 50010, USA
Phone: +1 515 239 6000

**Danfoss
Power Solutions GmbH & Co. OHG**
Krokamp 35
D-24539 Neumünster, Germany
Phone: +49 4321 871 0

**Danfoss
Power Solutions ApS**
Nordborgvej 81
DK-6430 Nordborg, Denmark
Phone: +45 7488 2222

**Danfoss
Power Solutions Trading
(Shanghai) Co., Ltd.**
Building #22, No. 1000 Jin Hai Rd
Jin Qiao, Pudong New District
Shanghai, China 201206
Phone: +86 21 2080 6201

Danfoss can accept no responsibility for possible errors in catalogues, brochures and other printed material. Danfoss reserves the right to alter its products without notice. This also applies to products already on order provided that such alterations can be made without subsequent changes being necessary in specifications already agreed. All trademarks in this material are property of the respective companies. Danfoss and the Danfoss logotype are trademarks of Danfoss A/S. All rights reserved.