

ENGINEERING  
TOMORROW



Technical Information

# D Series and XD Series

## Fixed Displacement Gear Pumps

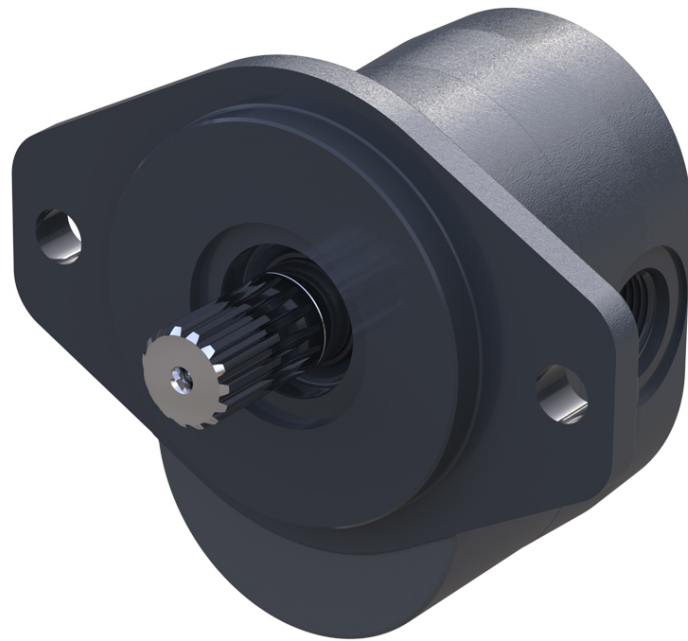

**Revision history**

*Table of revisions*

<b>Date</b>	<b>Changed</b>	<b>Rev</b>
April 2020	Corrected XD Model Code Information	0202
December 2019		0201
October 2019	First edition	0101

## Contents

### General Information

Overview.....	6
Features and benefits.....	6
Quick chart overview.....	6
Typical applications.....	7
Design.....	7
System schematic.....	8
Product features.....	9

### Technical Specifications

Technical specifications.....	10
Fluid specifications.....	10
Inlet pressure.....	10

### Operating Parameters

Sizing equations.....	11
Pressure.....	11
Temperature and viscosity.....	12
Speed.....	12
Hydraulic fluid.....	13
Filtration.....	13
Filters.....	13
Selecting a filter.....	13
Reservoir.....	13
Line sizing.....	14
Pump life.....	14
Pump shaft connection.....	14
Radial and axial loading.....	15

### D Series Model Code

Single pump order code.....	16
DE1: D series cast iron gear pump, single section.....	16
A Rotation - viewed from drive shaft.....	16
B1 Displacement.....	16
B2 Input shaft.....	17
C Mounting flange.....	17
D Rear cover: Port options, integrated valves, and auxillary flange.....	18
E Flow control valve setting.....	19
F Pressure control valve setting.....	20
H Assembly Screws - depending on rear cover.....	21
J Nameplates.....	23
K Special feature.....	23
Two section (tandem) pump order code.....	23
A Rotation - viewed from drive shaft.....	23
B1 Displacement.....	24
B2 Input shaft.....	24
C Mounting flange.....	25
R Ports - First section.....	25
S Displacement - Second section.....	26
D Rear cover: Port options, integrated valves and auxillary flange.....	26
E Flow control valve.....	28
F Pressure control valve.....	29
H Assembly screws.....	30
J Nameplate.....	33
K Special features.....	33
Three section (triple) pump order code.....	33
A Rotation - viewed from drive shaft.....	34
B1 Displacement - First section.....	34
B2 Input shaft.....	34
C Mounting flange.....	35
L Ports - First section.....	35

**Contents**

M Displacement - Second section.....	36
R Ports - Second section.....	37
S Displacement - Third section.....	37
D Rear cover: Port options, integrated valves and auxiliary.....	38
E Flow control valve.....	40
F Pressure control valve.....	40
H Assembly screws.....	41
J Nameplate.....	41
K Special feature.....	42
Four section (quad) pump order code.....	42
A Rotation - viewed from drive shaft.....	42
B1 Displacement - First section.....	43
B2 Input shaft.....	43
C Mounting flange.....	44
L Ports - First section.....	44
M Displacement - Second section.....	45
N Ports - Second section.....	45
P Displacement - Third section.....	46
R Ports - Third Section.....	47
S Displacement - Fourth section.....	47
D Rear cover: Port options, integrated valves and auxiliary flange.....	48
E Flow control valve.....	50
F Pressure control valve.....	51
H Assembly screws.....	51
J Nameplate.....	52
K Special feature.....	52

**D Series Options**

Shaft options.....	53
Mounting flanges.....	54
Multiple pump port options.....	56
Rear cover - port options.....	58
Integrated Priority Flow Divider.....	62
Integrated Priority Flow Divider.....	64
Integrated Steering Cover.....	64
Integrated Steering Cover.....	65
Load Sense Priority Flow Valve.....	66
Pumps with Load Sense Priority Flow Valves.....	67

**D Series Dimension Drawings**

One Section - Single.....	69
Two section - Tandem.....	70
Three Section - Triple.....	71
Four Section - Quad.....	72

**D Series Performance Data**

Flow performance.....	73
-----------------------	----

**XD Model Code Information**

A Rotation - viewed from drive shaft.....	78
B1 Displacement - front section.....	78
B2 Input shaft.....	78
C Mounting flange.....	79
R Ports - first section.....	79
S Displacement - rear section.....	79
D Rear cover.....	79
E Flow control valve.....	80
F Pressure control valve.....	80
H Assembly screws.....	80
J Name plate.....	80
K Special features.....	80

**Contents**

**XD Options**

XD Shaft options.....	81
XD Mounting flanges.....	81

**XD Dimension Drawings Information**

Dimensions.....	84
-----------------	----

## General Information

### Overview

The D Series fixed displacement gear pump has been specifically designed for demanding mobile equipment applications where maximum performance is required at peak power levels and operating temperatures.

The design integrates cast iron construction with pressure balanced thrust plates to deliver consistent efficiency across the entire operating range of pressure, speed, and temperature; all in an industry-leading package size that maximizes power density.

### Features and benefits

- High strength cast iron construction allows consistently efficient performance and long life in continuous operation at 276 bar [4000 psi] and peak conditions of 303 bar [4400 psi].
- Custom engineered bearings, pressure-balanced load plates, and viton seals optimize internal lubrication allowing for long life with intermittent fluid temperatures up to 115 °C [239 °F] and fluid viscosities as low as 8 mm<sup>2</sup>/sec (cSt) [36 SUS].
- Compact three-piece design maximizes power density and creates one of the shortest multisection pumps (with up to four pumping sections) in the global marketplace.
- Bearings located in the front flange increase radial/axial load carrying capability and eliminate the need for most bolt-on outrigger bearings.

### Quick chart overview

The D Series pump blends the traditional Group 2 (SAE-A) and Group 3 (SAE-B) frame sizes in a single package with displacements from 7 to 45 cm<sup>3</sup> (0.43 to 2.75 in<sup>3</sup>).

These displacements, in addition to a wide variety of shafts, flanges, ports, and integrated valve options can be used in virtually any combination to offer greater design flexibility and meet specific application requirements.

*Gear pumps quick chart overview*

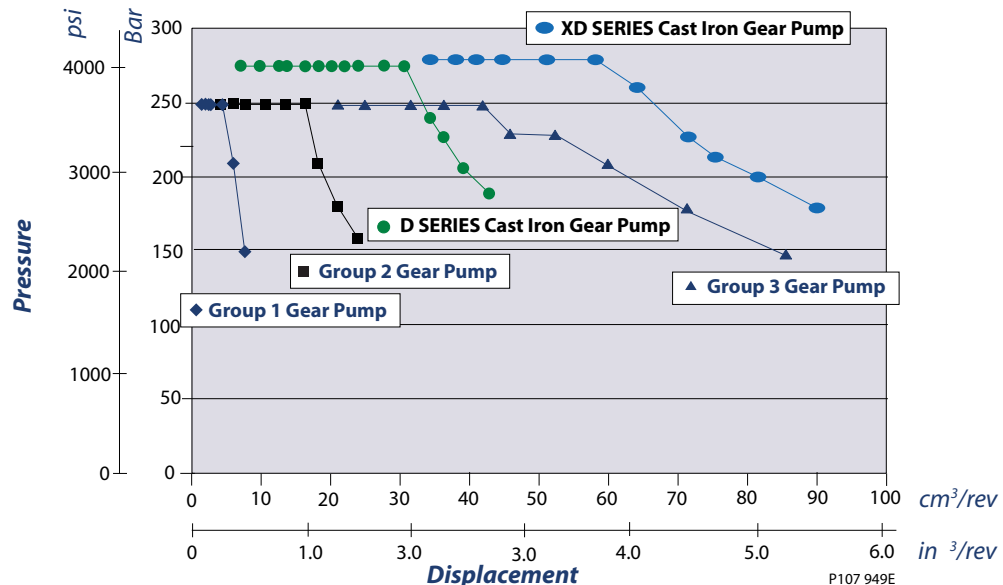

## General Information

### Typical applications

The D Series gear pump is commonly applied in the following type of applications:

- Wheel loader - Aggressive duty cycles with continuous working pressures above 250 bar [3600 psi]
- Mining equipment - Increased exposure to system contamination in a corrosive environment
- Skid steer loaders - Multiple pump combinations with short length and common inlets
- Work function attachments - Rapid loading of cylinders/motors in high bulk modulus systems causing pressure rise rates greater than 3000 bar/sec
- Agricultural sprayers - Pumps with integrated valves including priority flow dividers and load sense steering
- Pavers - D pumps integrated with other Turolla components including variable displacement piston pumps, aluminum gear pumps and cartridge valves
- Fan drives - High levels of performance with elevated temperatures and minimal oil viscosities and restrictive envelope dimensions

### Design

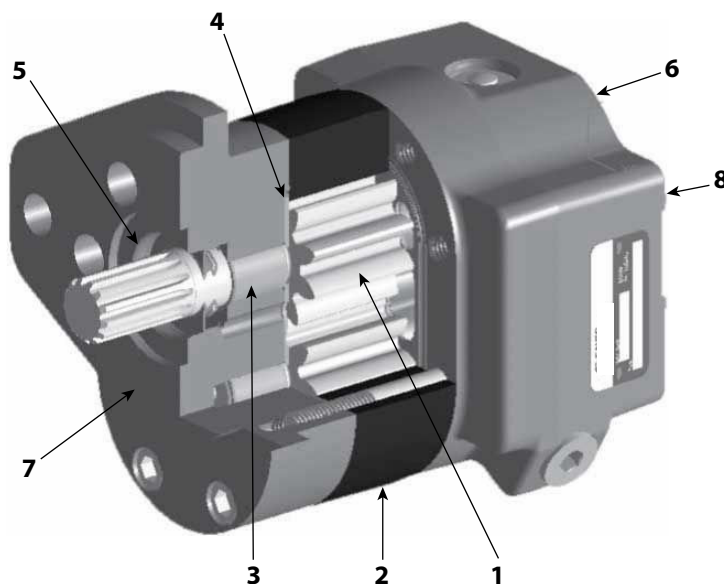

1. High-quality, heat-treated alloy steel integral gears and shaft
2. High-strength ductile iron body and covers
3. Heavy-duty low-friction sleeve bushings
4. Pressure balanced bronze-on-steel thrust plates
5. High temperature Viton seals
6. *Optional:* flow control with load sensing priority flow or factory preset fixed priority flow divider valve
7. SAE-A/SAE-B 2-bolts mounting flange
8. *Optional:* Side or rear port options

### Cast iron housings, bearings

The three piece structural members of the pump are made of high-strength cast ductile iron. Cast iron provides contamination resistance, thermal stability and the strength needed for consistently high levels of performance and durability needed in demanding off highway applications.

Heavy-duty low friction PTFE-lined sleeve bushings are optimized to provide long life in low viscosity, high pressure conditions. The bearings are located in the front mounting flange, rear cover, and bearing plate (for multiple section pumps) and allow the D pump to be 20% shorter than a typical bearing block

## General Information

design pump. In addition, the proximity of the front bearing to the mounting flange increases the radial load capacity of the pump, eliminating the need for most bolt-on outrigger requirements.

### Pressure balance, sealing

The pump incorporates two steel-backed bronze thrust plates seated in depressions in the mounting flange, rear cover, and bearing plate (for multiple section pumps). Underneath the front plate (known as the deflecting plate) is the load seal.

The E-shaped load seal distributes system pressure underneath the plate and enables the plate to deflect and maintain a tight sealing surface against the side face of the gears.

The tight sealing action allows the pump to maintain very high levels of volumetric efficiency, even when operating in extreme temperature, pressure and speed conditions.

### One-piece gear design

All D Series pump gear shafts are of one-piece design. This enables the shaft to provide uniform high strength and accurate gear profile relative to the journals for smooth mesh operation. The integral gear shafts are made of heat treated AISI 8620 steel, manufactured to precise tolerances and surface finishes, for maximal life and minimal leakage. This integral design eliminates the potential problems of fatigue stress and gear face mismatch often associated with two-piece gear shaft designs.

### Multiple pump configuration

D Series pumps can be coupled together to produce tandem, triple and even quadruple section units. The interconnecting chambers accommodate fluid flow between sections and allow the number of inlet connections to be minimized. Systems that require operation with different fluids and/or reservoirs can be accommodated with sealed auxiliary covers between sections.

## System schematic

*Gear Pump/Gear Motor Fan Drive System with Electronic Control*

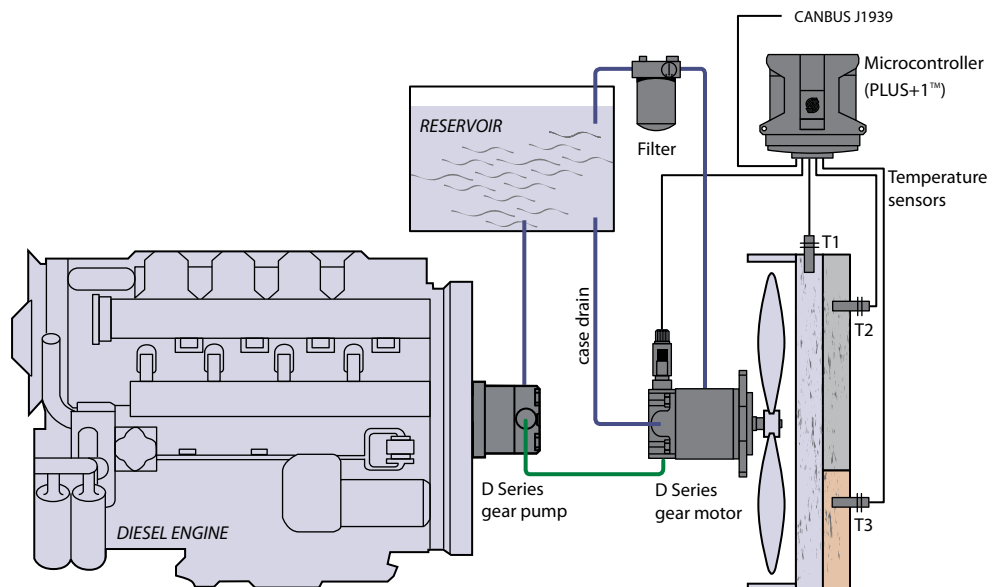

P107 929E



## General Information

### Product features

Features	Description
<b>Construction</b>	Heavy duty ductile iron 3-piece construction with pressure balance load plates and viton seals
<b>Displacements</b>	7 to 45 cm <sup>3</sup> [0.43 to 2.75 in <sup>3</sup> /rev]
<b>Continuous Pressure</b>	276 bar [4000 psi] up to 32 cm <sup>3</sup> [1.94 in <sup>3</sup> /rev]
<b>Peak Pressure</b>	303 bar [4400 psi] up to 32 cm <sup>3</sup> [1.94 in <sup>3</sup> /rev]
<b>Speed</b>	600 to 3400 min <sup>-1</sup> (rpm) - up to 25cm <sup>3</sup> [1.55 in <sup>3</sup> /rev]
<b>Mounting</b>	SAE A two bolt, SAE B two bolt, Perkins engine mount
<b>Shaft (types)</b>	Straight keyed, 1:8 tapered keyed, 9T, 11T, 13T and 15T splined
<b>Ports</b>	SAE O-ring boss, SAE split flange, beaded tube inlet (axial and radial)
<b>Fluid viscosity*</b>	8 mm <sup>2</sup> /sec (cSt) [36 SUS] minimum, 1600 mm <sup>2</sup> /sec (cSt) [7500 SUS] maximum
<b>Filtration requirement</b>	22/18/13 ISO 4406 at motor inlet
<b>Fluids</b>	Petroleum/mineral based
<b>Operating temperature*</b>	-40°C [-40°F] minimum for cold start 110°C [230°F] normal operating conditions 115°C [239°F] peak intermittent
<b>Configurations</b>	Single, tandem, triple, and quadruple multisection pumps available with common inlets. Integrated auxiliary cover for through drive applications.
<b>Integrated valve options</b>	Priority flow divider with priority relief Priority steering with steering relief Load sense priority flow divider

\* Temperature and viscosity requirements must be satisfied concurrently.

## Technical Specifications

### Technical specifications

Ratings	Units	07	10	11	13	14	17	19	21	23	25	29	32	36	38	41	45
Displacement	cm <sup>3</sup> /rev	7.0	9.5	10.8	12.6	14.3	17.0	19.0	20.5	22.5	25.4	29.0	31.8	36.1	38.0	41.0	45.1
	in <sup>3</sup> /rev	0.43	0.58	0.66	0.77	0.87	1.04	1.16	1.25	1.37	1.55	1.77	1.94	2.20	2.32	2.50	2.75
Rated pressure	bar	276	276	276	276	276	276	276	276	276	276	276	276	241	228	207	190
	psi	4000	4000	4000	4000	4000	4000	4000	4000	4000	4000	4000	4000	3500	3300	3000	2750
Peak pressure	bar	303	303	303	303	303	303	303	303	303	303	303	303	265	250	228	209
	psi	4400	4400	4400	4400	4400	4400	4400	4400	4400	4400	4400	4400	3850	3630	3300	3025
Speed min <sup>-1</sup> (rpm)	maximum	3400	3400	3400	3400	3400	3400	3400	3400	3400	3400	3200	3000	2750	2750	2500	2500
	minimum*	1200	900	900	700	700	600	600	600	600	600	600	600	600	600	600	600
Theoretical flow at max speed	l/min	24.0	32.3	36.7	42.9	48.5	57.9	64.6	69.6	76.3	86.4	92.8	95.4	99.0	104.5	102.4	112.7
	US gal/min	6.3	8.5	9.7	11.3	12.8	15.3	17.1	18.4	20.2	22.8	24.5	25.2	26.2	27.6	27.1	29.8
Weight	kg	7.2	7.3	7.4	7.5	7.6	7.8	7.9	7.9	8.1	8.3	8.4	8.6	8.8	9.0	9.1	9.4
	lb	15.8	16.1	16.3	16.5	16.7	17.1	17.4	17.5	17.8	18.2	18.6	19.0	19.6	19.8	20.2	20.7
Mass moment of inertia	x10 <sup>-6</sup> kg·m <sup>2</sup>	60	71	77	85	92	104	105	119	128	141	157	170	188	197	218	228
	x10 <sup>-6</sup> slug·ft <sup>2</sup>	44	53	57	63	68	77	77	88	95	104	116	125	139	145	155	168

\* minimum speed at maximum pressure

### Fluid specifications

Parameter	Unit	Minimum	Continuous	Maximum
Viscosity*	mm <sup>2</sup> /sec (cSt)[SUS]	8 [52]	10 - 100 [59-456]	1600 [7500]
Temperature*	°C [°F]	-40 [-40]	110 [230]	115 [239]
Cleanliness		ISO 4406 Class 22/18/13 or better		
Filtration efficiency, charge filtration		b15-20 =75 (b10 <sup>3</sup> 10)		

\* Temperature and viscosity requirements must be satisfied concurrently

Ratings are based on operation with premium petroleum-based hydraulic fluids containing oxidation, rust, and foam inhibitors.

### Inlet pressure

Maximum continuous vacuum	bar atmospheric [inches mercury vacuum]	0.8 [5.9]
Maximum intermittent vacuum		0.6 [11.8]
Maximum charged inlet pressure	bar atmospheric [psi]	3.0 [44]

## Operating Parameters

### Sizing equations

Use these formulas to determine the nominal pump size for a specific application.

	<b>Based on SI units</b>		<b>Based on US units</b>
<b>Flow</b>	Output flow $Q_o = \frac{V_g \cdot n \cdot \eta_v}{1000}$ (l/min)		Output flow $Q_o = \frac{V_g \cdot n \cdot \eta_v}{231}$ (US gal/min)
	Input torque $M_i = \frac{V_g \cdot \Delta p}{20 \cdot \pi \cdot \eta_m}$ (N·m)		Input torque $M_i = \frac{V_g \cdot \Delta p}{2 \cdot \pi \cdot \eta_m}$ (lb·in)
<b>Power</b>	Input power $P_i = \frac{M_i \cdot n}{9550} = \frac{Q_o \cdot \Delta p}{600 \cdot \eta_t}$ (kW)		Input power $P_i = \frac{V_g \cdot n \cdot \Delta p}{396\,000 \cdot \eta_t}$ (hp)

### Variables SI units [US units]

$V_g$	= Displacement per revolution	cm <sup>3</sup> /rev [in <sup>3</sup> /rev]
$p_{iD}$	= Outlet pressure	bar [psi]
$p_{iD}$	= Inlet pressure	bar [psi]
$\Delta p$	= $p_{iD} - p_{iD}$ (system pressure)	bar [psi]
$n$	= Speed	min <sup>-1</sup> (rpm)
$\eta_v$	= Volumetric efficiency	
$\eta_{mh}$	= Mechanical efficiency	
$\eta_t$	= Overall efficiency ( $\eta_v \cdot \eta_m$ )	
$p$	= Differential hydraulic pressure	bar [psi]

## Pressure

Definitions of the D Series operating parameters appear below. Consult Danfoss technical support for applications running outside of these parameters.

### Peak pressure

Peak pressure is the highest intermittent pressure allowed. The relief valve overshoot (reaction time) determines peak pressure. It is assumed to occur for less than 100 ms. The illustration to the right shows peak pressure in relation to rated pressure and reaction time (100 ms maximum).

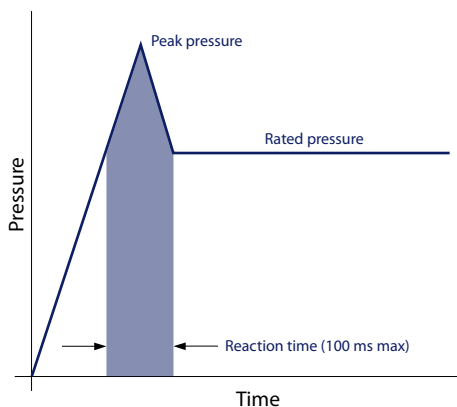

### Rated pressure

Rated pressure is the average, regularly occurring operating outlet pressure that should yield satisfactory product life. The maximum machine load demand determines rated pressure. For all systems, the load should move below this pressure.

## Operating Parameters

### System pressure

System pressure is the differential between the inlet and outlet ports. It is a dominant operating variable affecting hydraulic unit life. High system pressure reduces expected pump life. System pressure must remain at, or below, rated pressure during normal operation to achieve expected life.

### Inlet vacuum

Inlet vacuum must be controlled in order to realize expected performance and pump life. System design must meet inlet vacuum requirements during all modes of operation. Expect lower inlet vacuums during cold start situations. Low vacuum condition should improve quickly as fluid warms.

### Pressure rise rate

The maximum pressure rise rate is the rate of increase in system pressure as measured at the outlet port of the pump. High pressure rise rates are commonly seen on work function applications during motor start-up, completion of cylinder stroke, and during rapid shifting of control valves. The maximum pressure rise rate of the D pump is 11,720 bar/sec [170,000 psi/sec]. During rapid rise rate situations, the system pressure must not exceed the rated pressure of the pump.

## Temperature and viscosity

### Temperature

High temperature limits apply at the inlet port of the pump. The pump should run at or below the maximum continuous temperature.

**Minimum (cold start) temperature** relates to the physical properties of component materials.

Cold oil, generally, doesn't affect the durability of pump components. It may affect the ability of oil to flow and transmit power. For this reason, keep the temperature at 16°C [29 °F] above the pour point of the hydraulic fluid.

**Continuous temperature** is the temperature at or below the temperature which normal pump life can be expected.

**Maximum temperature** is the highest temperature that is tolerable by the machine for a transient/limited time (duty cycle 1% or less). At maximum temperature, oil viscosity must not go lower than minimum recommended viscosity.

### Viscosity

**Continuous viscosity:** Recommended viscosity range for maximum efficiency and pump life.

**Minimum viscosity** occurs only during brief occasions of maximum fluid temperature and severe duty cycle operation. It's the minimum acceptable viscosity to guarantee the pump life. (Duty cycle 1% or less)

**Maximum viscosity** occurs only during cold start at very low temperatures. It is the upper limit of viscosity that allows the pump to start. During this condition, limit speeds until the system warms up.

---

[Temperature and viscosity requirements must be concurrently satisfied.](#)

---

## Speed

**Maximum speed** is the limit recommended for operation at rated pressure. It is the highest speed at which normal life can be expected.

The lower limit of operating speed is the **minimum speed**.

## Operating Parameters

### Hydraulic fluid

Ratings and data for gear pumps are based on operation with premium hydraulic fluids containing oxidation, rust, and foam inhibitors. These fluids must possess good thermal and hydrolytic stability to prevent wear, erosion, and corrosion of internal components.

Use only clean fluid in the pump and hydraulic circuit.

**! Caution**

**Never mix hydraulic fluids.**

### Filtration

#### Filters

Use a filter that conforms to Class 22/18/13 of ISO 4406 (or better). It may be on the pump outlet (pressure filtration), inlet (suction filtration), or reservoir return (return-line filtration).

#### Selecting a filter

When selecting a filter, please consider:

- contaminant ingress rate (determined by factors such as the number of actuators used in the system)
- generation of contaminants in the system
- required fluid cleanliness
- desired maintenance interval
- filtration requirements of other system components

Measure filter efficiency with a Beta ratio ( $\beta_x$ ). For:

- suction filtration, with controlled reservoir ingress, use a  $\beta_{35-45} = 75$  filter
- return or pressure filtration, use a pressure filtration with an efficiency of  $\beta_{10} = 75$

$\beta_x$  ratio is a measure of filter efficiency defined by ISO 4572. It is the ratio of the number of particles greater than a given diameter ("x" in microns) upstream of the filter to the number of these particles downstream of the filter.

#### Fluid cleanliness level and $\beta_x$ ratio

<b>Fluid cleanliness level (per ISO 4406)</b>	Class 22/18/13 or better
<b><math>\beta_x</math> ratio (suction filtration)</b>	$\beta_{35-45} = 75$ and $\beta_{10} = 2$
<b><math>\beta_x</math> ratio (pressure or return filtration)</b>	$\beta_{10} = 75$
<b>Recommended inlet screen size</b>	100-125 $\mu\text{m}$ [0.004-0.005 in]

The filtration requirements for each system are unique. Evaluate filtration system capacity by monitoring and testing prototypes.

#### Reservoir

The **reservoir** provides clean fluid, dissipates heat, removes entrained air, and allows fluid volume changes associated with fluid expansion and cylinder differential volumes. A correctly sized reservoir accommodates maximum volume changes during all system operating modes. It promotes deaeration of the fluid as it passes through, and accommodates a fluid dwell-time between 60 and 180 seconds, allowing entrained air to escape.

**Minimum reservoir capacity** depends on the volume required to cool and hold the oil from all retracted cylinders, allowing for expansion due to temperature changes. A fluid volume of 1 to 3 times the pump output flow (per minute) is satisfactory. The minimum reservoir capacity is 125% of the fluid volume.

Install the suction line above the bottom of the reservoir to take advantage of gravity separation and prevent large foreign particles from entering the line. Cover the line with a 100-125 micron screen. The

## Operating Parameters

pump should be below the lowest expected fluid level. Put the return-line below the lowest expected fluid level to allow discharge into the reservoir for maximum dwell and efficient deaeration. A baffle (or baffles) between the return and suction lines promotes deaeration and reduces fluid surges.

## Line sizing

Choose line sizes that accommodate maximum fluid velocity to reduce system noise, pressure drops, and overheating in order to maximize system life and performance. Line velocities shown in the following table provide a general rule of thumb. Final selection of line sizing and fittings must comply with all pressure ratings.

<b>Inlet</b>	<b>m/sec [ft/sec]</b>	2.4-4.3 [8-14]
<b>Outlet</b>		6-9 [20-30]

Most systems use hydraulic oil containing 10% dissolved air by volume. Over-eration, or entrained air is the result of flow line restrictions, where the dissolved air comes out of solution, or when air is allowed to leak into the hydraulic circuit. These include inadequate pipe sizes, sharp bends, or elbow fittings, causing reduction of flow-line cross-sectional area. This problem will not occur if these circuit recommendations are followed, rated speed requirements are maintained, and reservoir size and location are adequate.

## Pump life

Pump life is a function of speed, system pressure, and other system parameters (such as fluid quality and cleanliness).

All Danfoss gear pumps use hydrodynamic journal bearings with an oil film between the gear/shaft and bearing surfaces. If the oil film is sufficiently sustained through proper system maintenance and operating within recommended limits, long life can be expected.

[β10 life expectancy number is generally associated with rolling element bearings. It does not exist for hydrodynamic bearings.](#)

When submitting an application for review, provide machine duty cycle data including percentage of time at various loads and speeds. We strongly recommend a prototype testing program to verify operating parameters and their impact on life expectancy before finalizing any system design.

## Pump shaft connection

Shaft options for gear pumps include tapered, splined, or parallel shafts.

Plug-in drives, with a splined shaft, can impose severe radial loads when the mating spline is rigidly supported. Increasing spline clearance does not alleviate this condition.

### *Pump shaft connection*

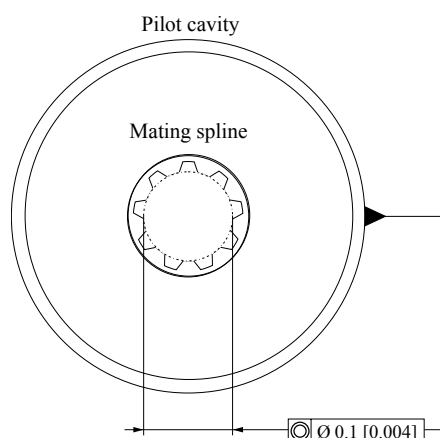

## Operating Parameters

Lubricate all shaft couplings. Failure to do so will result in premature shaft failure.

Use plug-in drives if the concentricity between the mating spline and pilot diameter is within 0.1 mm [0.004 in]. Lubricate the drive by flooding it with oil. A 3-piece coupling minimizes radial or thrust shaft loads.

**! Caution**

To avoid spline shaft damages it is recommended to use carburized and hardened steel couplings with 80-82 HRA surface hardness.

## Radial and axial loading

Allowable radial shaft loads are a function of the load position, load orientation, and operating pressure. All external shaft loads have an effect on bearing life, and may affect pump performance.

In applications where external shaft loads cannot be avoided, minimize the impact on the pump by optimizing the orientation and magnitude of the load. Use tapered input shafts for applications with radial shaft loads. The table below shows the preferred orientation for radial loads assuming maximum pressure. For assistance concerning shaft loading, contact your Danfoss representative.

Maximum radial and axial loads

Ratings	Units	7	10	11	13	14	17	19	21	23	25	29	32	36	38	41	45
Maximum radial load	lbf	1430	1430	1430	1430	1430	1430	1360	1300	1210	1070	870	700	420	270	450	620
	N	6361	6361	6361	6361	6361	6361	5943	5783	5382	4760	3870	3114	1868	1201	2002	2758
Push/Pull axial load	lbf	350	350	350	350	350	350	350	350	350	350	350	350	350	350	350	350
	N	1557	1557	1557	1557	1557	1557	1557	1557	1557	1557	1557	1557	1557	1557	1557	1557

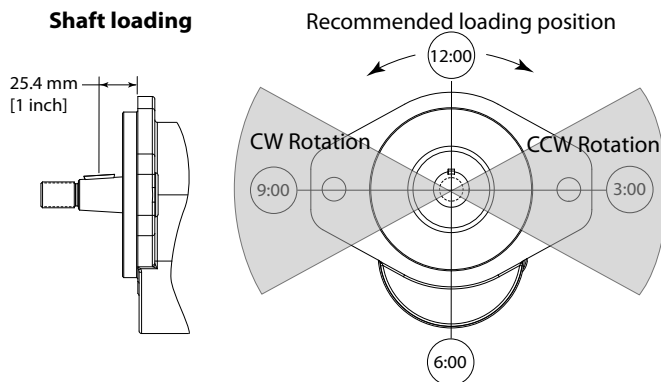

- All values measured 25.4 mm [1 inch] from the mounting flange
- For other orientations and distances, higher radial loads at lower pressures contact your S-D representative

P107 928E

D Series Model Code

Single pump order code

Example

A			B1		B2		C		D				E			F			H		J		K			
D	E	1	R	2	1	S	H	A	C	F	0	9	A	1	5	X	1	7	2	C	Z	A	N	N	N	N

Code	Position	Description
DE1R	A	D Series pump, single section, right hand rotation
21	B1	21 cm <sup>3</sup> displacement
SH	B2	13 tooth spline input shaft
AC	C	SAE A two bolt mounting flange
F09A	D	Integrated priority flow divider with cartridge style priority relief, 1 5/16-12 side inlet, 3/14-16 side priority, 7/8-14 side secondary
15X	E	15.1 l/min[4 US gal/min] priority flow setting
172	F	172 bar [2495 psi] priority relief setting
CZ	H	Assembly screws
AN	J	Standard Nameplate
NNN	K	No special features, black paint

DE1: D series cast iron gear pump, single section

*A Rotation - viewed from drive shaft*

A			B1		B2		C		D				E			F			H		J		K		
D	E	1	•																						

Code	Description
L	Lefthand (counterclockwise)
R	Right hand (clockwise)

*B1 Displacement*

A			B1		B2		C		D				E			F			H		J		K		
D	E	1	•	•																					

Code	Description
07	7.0 cm <sup>3</sup> /rev [0.43 in <sup>3</sup> /rev]
10	9.5 cm <sup>3</sup> /rev [0.58 in <sup>3</sup> /rev]
11	10.8cm <sup>3</sup> /rev [0.66 in <sup>3</sup> /rev]
13	12.6cm <sup>3</sup> /rev [0.77 in <sup>3</sup> /rev]
14	14.3cm <sup>3</sup> /rev [0.87 in <sup>3</sup> /rev]
17	17.0cm <sup>3</sup> /rev [1.04 in <sup>3</sup> /rev]
19	19.0cm <sup>3</sup> /rev [1.16 in <sup>3</sup> /rev]
21	20.5cm <sup>3</sup> /rev [1.25 in <sup>3</sup> /rev]
23	22.5 cm <sup>3</sup> /rev [1.37 in <sup>3</sup> /rev]
25	25.4 cm <sup>3</sup> /rev [1.55 in <sup>3</sup> /rev]



### D Series Model Code

Code	Description
29	29.0 cm <sup>3</sup> /rev [1.77 in <sup>3</sup> /rev]
32	31.8 cm <sup>3</sup> /rev [1.94 in <sup>3</sup> /rev]
36	36.1 cm <sup>3</sup> /rev [2.20 in <sup>3</sup> /rev]
38	38.0 cm <sup>3</sup> /rev [2.32 in <sup>3</sup> /rev]
41	41.0 cm <sup>3</sup> /rev [2.50 in <sup>3</sup> /rev]
45	45.1 cm <sup>3</sup> /rev [2.75 in <sup>3</sup> /rev]

### B2 Input shaft

A			B1	B2	C	D			E	F	H	J	K
D	E	1		• •									

Code	Description
SE*	SAE 9 tooth spline, 31.8 mm [1.25 in] length
SC	SAE 11 tooth spline, 38.1 mm [1.5 in] length
SF	11 tooth spline, 31.8 mm [1.25 in] length (special modified length)
SH	SAE 13 tooth spline, 41 mm [1.62 in] length
SV	15 tooth spline, 46 mm [1.81 in] length (use with mounting flange AR or BR)
PB	22 mm [7/8 in] diameter, 41 mm [1.62 in] length, with 1/4 key
PD	19 mm [3/4 in] diameter, 51 mm [2 in] length, with 3/16 key
PZ	25.4 mm [1 in] diameter, 46 mm [1.81 in] length with 1/4 key
TA	1:5taper, 25mm [1 in] dia, 58mm [2.30 in] length, 5/8 thread, M5 key with locknut and washer
TG	1:8taper, 22mm [7/8 in] dia, 50mm [1.95 in] length, 5/8 thread with key, locknut and washer
TH	1:8taper, 22mm [7/8 in] dia, 49mm [1.94 in] length, 9/16 thread with key, locknut and washer
TX	1:4 taper, 22mm [7/8 in] dia, 50mm [1.98 in] length, 5/16 internal thread with key
WT	Input shaft similar to TH option with 34 tooth helical gear for Perkins engine mount
AB	22mm[7/8 in] diameter, 41mm [1.62] length with 1/4 key with 9T spline through drive
AC	SAE 11 tooth spline, 38.1 mm [1.5 in] length with 9T spline through drive
AH	SAE 13 tooth spline, 41 mm [1.62 in] length with 9T spline through drive

\* Contact factory for units with SE (9T spline) to verify torque limits

### C Mounting flange

A			B1	B2	C	D			E	F	H	J	K
D	E	1			• •								

Code	Description
AA	SAE A 2-bolt
AC	SAE A 2-bolt, use with integral PFD/Steering Cover
AL	SAE A 2-bolt, two shaft seals with weep hole
AM	SAE A 2-bolt, with T seal
AP	SAE A 2-bolt, with T seal, use with integral PFD/Steering cover
AR	SAE A 2-bolt, use with 15 T spline input drive

### D Series Model Code

Code	Description
AS	SAE A 2-bolt, use with integral PFD/Steering cover and 15 T input spline
AT	SAE A 2-bolt, two shaft seals with weep hole, use with integral PFD/Steering cover
BB	SAE B 2-bolt
BC	SAE B 2-bolt, use with integral PFD/Steering cover
BM	SAE B 2-bolt, with T seal
BP	SAE B 2-bolt, with T seal, use with integral PFD/Steering cover
BR	SAE B 2-bolt, use with 15 T spline input drive
BS	SAE B 2-bolt, use with integral PFD/Steering cover and 15 T input spline
BT	SAE B 2-bolt, two shaft seals with weep hole, use with integral PFD/Steering Cover
BW	SAE B 2-bolt, two shaft seals with weep hole
PP	Perkins 6 bolt flange with (2) seals (use with WT input shaft and clockwise rotation)

### D Rear cover: Port options, integrated valves, and auxiliary flange

A			B1	B2	C	D				E	F	H	J	K	
D	E	1				•	•	•	•						

Code	Inlet	Outlet	Description
N101	1 1/16-12 side inlet	7/8-14 side outlet	SAE O-ring boss ports No integrated valves No auxiliary flange
N103	1 5/16-12 side inlet	7/8-14 side outlet	
N104	1 5/16-12 side inlet	1 1/16-12 side outlet	
N125	1 5/8-12 side inlet	1 1/16-12 side outlet	
N501	1 1/16-12 rear inlet	7/8-14 rear outlet	
N503	1 5/16-12 rear inlet	7/8-14 rear outlet	
N504	1 5/16-12 rear inlet	1 1/16-12 rear outlet	
N252	M33x2-6H rear inlet	M22x1.5-6H side outlet	SAE Metric Ports – No Integrated Valves
N402	3/4-14 side inlet	1/2-14 side outlet	British Standard Pipe Parallel (BSPP) threads - No integrated valves
N403	1-11 side inlet	1/2-14 side outlet	
N404	1 1/4-11 side inlet	1/2-14 side outlet	
N407	1-11 side inlet	3/4-14 side outlet	
N408	1 1/4-11 side inlet	3/4-14 side outlet	
N342	1 1/4 side split flange inlet	3/4 side split flange outlet (SAE code 61)	SAE split flange ports No integrated valves No auxiliary flange
N704	1 1/4 side tube inlet	7/8-14 side ORB outlet	Beaded tube inlet port, SAE O-ring boss outlet port No integrated valves No auxiliary flange
N708	1 1/4 side tube inlet	1 1/16-12 side ORB outlet	
N715	1 1/4 REAR tube inlet	1 1/16-12 REAR ORB outlet	
N716	1 1/2 side tube inlet	1 1/16-12 side ORB outlet	
N720	1 1/4 REAR tube inlet	7/8-14 REAR ORB outlet	
N720	1 1/4 REAR tube inlet	7/8-14 REAR ORB outlet	
B103*	1 5/16-12 side inlet	7/8-14 side outlet	SAE-A2-Bolt Auxiliary Flange SAE O-ring boss ports No integrated valves
B104*	1 5/16-12 side inlet	1 1/16-12 side outlet	

**D Series Model Code**

Code	Inlet	Outlet	Description
<b>R104</b>	1 5/16-12 side inlet	1 1/16-12 side outlet	Integrated Relief Valve Internally Drained Maximum Displacement 23cc
<b>F09A**</b>	15/16-12 side inlet, 3/4-16 side priority, 7/8-14 side secondary (SAE A flange)		Integrated Priority Flow Divider, cartridge style relief for settings up to: 221 bar and 34.3 l/min [3200 psi and 9 US gal/min]
<b>F09B‡</b>	1 5/8-12 rear inlet, 3/4-16 rear priority, 7/8-14 rear secondary (SAE A flange)		
<b>F13A**</b>	1 5/8-12 rear inlet, 3/4-16 rear priority, 7/8-14 rear secondary (SAE A flange)		
<b>F13B‡</b>	1 5/8-12 rear inlet, 3/4-16 rear priority, 7/8-14 rear secondary (SAE B flange)		
<b>F21A**</b>	15/8-12 side inlet, 3/4-16 side priority, 7/8-14 side secondary (SAE A flange)		
<b>F21B‡</b>	15/8-12 side inlet, 3/4-16 side priority, 7/8-14 side secondary (SAE B flange)		
<b>F25A**</b>	1 5/16-12 rear inlet, 3/4-16 rear priority, 7/8-14 rear secondary (SAE A flange)		
<b>F25B‡</b>	1 5/16-12 rear inlet, 3/4-16 rear priority, 7/8-14 rear secondary (SAE B flange)		
<b>D23A*</b>	15/16-12 side inlet, 3/4-16 side priority, no secondary port (SAE A flange)		Integrated Steering Cover, Priority Relief Valve (Cartridge Style) for settings up to: 221 bar and 34.3 l/min [3200 psi and 9 US gal/min]
<b>D23B**</b>	15/16-12 side inlet, 3/4-16 side priority, no secondary port (SAE B flange)		
<b>D24A*</b>	1 5/16-12 rear inlet, 3/4-16 rear priority, no secondary port (SAE A flange)		
<b>D24B**</b>	1 5/16-12 rear inlet, 3/4-16 rear priority, no secondary port (SAE B flange)		
<b>L01A**</b>	1 5/16-12 side inlet, 3/4-16 side priority, 7/8-14 side secondary, 7/16-20 side LS (SAE-A flange)		Integrated Load Sense Divider (Dynamic), Priority Relief Valve
<b>L01B‡</b>	1 5/16-12 side inlet, 3/4-16 side priority, 7/8-14 side secondary, 7/16-20 side LS (SAE-B flange)		
<b>L08A**</b>	1 5/16-12 rear inlet, 3/4-16 rear priority, 7/8-14 rear secondary, 7/16-20 rear LS (SAE-A flange)		
<b>L08B‡</b>	1 5/16-12 rear inlet, 3/4-16 rear priority, 7/8-14 rear secondary, 7/16-20 rear LS (SAE-B flange)		

\* Integrated auxiliary flange requires use of input shaft option AH or AC

\*\* Requires use of mounting flange option AC or AP

‡ Requires use of mounting flange option BC or BP

[A variety of integrated load sense priority flow divider covers are available from Danfoss. Please contact your technical representative to determine which hardware best suits specific application needs.](#)

**E Flow control valve setting**

A			B1	B2	C	D			E			F	H	J	K			
D	E	1								•	•	•						

**D Series Model Code**

Code	Description	
<b>NNN</b>	Noflow control setting, standard for units without integrated flow control valves	
<b>04X</b>	3.8 l/min [1 US gal/min]	For integrated PFD Steering cover with cartridge style relief valve (Cover options F09A, F09B, F13A, F13B, F21A, F21B, F25A or F25B)
<b>08X</b>	7.6 l/min [2 US gal/min]	
<b>11X</b>	11.4 l/min [3 US gal/min]	
<b>15X</b>	15.1 l/min [4 US gal/min]	
<b>19X</b>	18.9 l/min [5 US gal/min]	
<b>23X</b>	22.7 l/min [6 US gal/min]	
<b>27X</b>	26.5 l/min [7 US gal/min]	
<b>30X</b>	30.3 l/min [8 US gal/min]	
<b>34X</b>	34.3 l/min [9 US gal/min]	
<b>38A</b>	10 bar standby	
<b>38L</b>	10 bar standby	Forintegrated load sense divider (use with L01A or L01B side ports)
<b>R1N</b>	Maximum flow not to exceed 75 l/min, pressure range from 7-55bar	For integrated relief valve, internally drained (without flow control) Use with R104 cover option 23cc and under
<b>R2N</b>	Maximum flow not to exceed 75 l/min, pressure range from 41-248bar	For integrated relief valve, internally drained (without flow control) Use with R104 cover option 23cc and under

**F Pressure control valve setting**

A			B1	B2	C	D			E	F			H	J	K			
D	E	1									•	•	•					

### D Series Model Code

Code	Description	
000	Nopressure control settings, standard for units without integrated pressure control valves	
034	34 bar [500 psi]	<p>For integrated priority flow divider (PFD) cover with cartridge style relief valve (Cover options F09A, F09B, F13A, F13B, F21A, F21B, F25A, F25B)</p> <p>For integrated steering cover with cartridge style relief valve (Cover options D23A, D23B, D24A, D24B)</p> <p>For integrated load sense (LS) cover with cartridge relief valve (Cover options L01A, L01B, L08A, L08B)</p>
041	41 bar [600 psi]	
048	48 bar [700 psi]	
055	55 bar [800 psi]	
062	62 bar [900 psi]	
069	69 bar [1000 psi]	
076	76 bar [1100 psi]	
083	83 bar [1200 psi]	
090	90 bar [1300 psi]	
097	97 bar [1400 psi]	
103	103 bar [1500 psi]	
110	110 bar [1600 psi]	
117	117 bar [1700 psi]	
124	124 bar [1800 psi]	
131	131 bar [1900 psi]	
138	138 bar [2000 psi]	
145	145 bar [2100 psi]	
152	152 bar [2200 psi]	
159	159 bar [2300 psi]	
165	165 bar [2400 psi]	
172	172 bar [2500 psi]	
179	179 bar [2600 psi]	
186	186 bar [2700 psi]	
193	193 bar [2800 psi]	
200	200 bar [2900 psi]	
207	207 bar [3000 psi]	
214	214 bar [3100 psi]	
221	221 bar [3200 psi]	

#### H Assembly Screws - depending on rear cover

A			B1			B2			C			D			E			F			H		J			K		
D	E	1																			•	•						

(Choose Table 1 or Table 2)

Table 1. Single pumps without auxiliary cover or integrated valves

Displacement (Module B)	Rear Cover - Controls & Ports (Module D)	
	N101, N103, N104, N501, N503, N504, N704, N708	N125
07	AF	AJ
10	AG	AJ

## D Series Model Code

Table 1. Single pumps without auxiliary cover or integrated valves (continued)

Displacement (Module B)	Rear Cover - Controls & Ports (Module D)	
	N101, N103, N104, N501, N503, N504, N704, N708	N125
11	AG	AJ
13	AG	AJ
14	AG	AK
17	AH	AK
19	AH	AK
21	AH	AL
23	AJ	AL
25	AJ	AL
29	AK	AM
32	AK	AM
36	AL	AN
38	AL	AN
41	AM	AP
45	AM	AR

Table 2. Single pumps with auxiliary cover or integrated valves, dependent on rotation

Displacement (Module B)	Rear Cover - Controls & Ports (Module D)					
	Right Hand (CW) Rotation			Left Hand (CCW) Rotation		
	F09A F13A, F21A	F09B F13B, F21B	B104	F09A F13A, F21A	F09B F13B, F21B	B104
07	CV	DG	AG	EM	DG	AG
10	CV	DG	AH	EM	DG	AH
11	CV	DG	AH	EM	DG	AH
13	CX	DJ	AH	EP	DJ	AH
14	CX	DJ	AH	EP	DJ	AH
17	CY	DK	AJ	ER	DK	AJ
19	CZ	DL	AJ	ES	DL	AJ
21	CZ	DL	AJ	ES	DL	AJ
23	CZ	DM	AJ	ES	DM	AJ
25	DA	DN	AK	ET	DN	AK
29	DB	DP	AK	EY	DP	AK
32	DC	DR	AL	EU	DR	AL
36	DD	DS	AM	EV	DS	AM
38	DE	DT	AM	EW	DT	AM
41	DE	DT	AM	EW	DT	AM
45	DF	DU	AN	EX	DU	AN

## D Series Model Code

### J Nameplates

A			B1	B2	C	D			E	F	H	J	K
D	E	1										•	•

Code	Description
AN	Standard nameplate

### K Special feature

A			B1	B2	C	D			E	F	H	J	K		
D	E	1											•	•	•

Code	Description
NNN	No special features, standard black paint

## Two section (tandem) pump order code

### Example

The order code below provides an example of a single section pump with integrated priority flow divider

A			B1	B2	C	R	S	D			E	F	H	J	K																
D	E	2	R	2	3	S	H	B	B	1	0	4	1	3	N	1	1	3	N	N	N	O	O	O	A	V	A	N	N	N	N

Code	Position	Description
DE2R	A	D Series pump with two pumping sections, right hand rotation
23	B1	23 cm <sup>3</sup> displacement on first section
SH	B2	13 tooth spline input shaft
BB	C	SAE B two bolt mounting flange
104	R	1 5/16-12 side inlet, 1 1/16 side outlet on first section
13	S	13 cm <sup>3</sup> displacement on second section
N113	D	No inlet and 7/8-14 side outlet on second section
NNN	E	No flow control setting
000	F	No pressure control setting
AV	H	Assembly screws
AN	J	Standard Nameplate
NNN	K	No special features, black paint

### A Rotation - viewed from drive shaft

A			B1	B2	C	R	S	D			E	F	H	J	K	
D	E	2	•													

Code	Description
L	Lefthand (counterclockwise)
R	Right hand (clockwise)

## D Series Model Code

### B1 Displacement

A			B1		B2	C	R	S	D	E	F	H	J	K
D	E	2	•	•										

Code	Description
07	7.0 cm <sup>3</sup> /rev [0.43 in <sup>3</sup> /rev]
10	9.5 cm <sup>3</sup> /rev [0.58 in <sup>3</sup> /rev]
11	10.8cm <sup>3</sup> /rev [0.66 in <sup>3</sup> /rev]
13	12.6cm <sup>3</sup> /rev [0.77 in <sup>3</sup> /rev]
14	14.3cm <sup>3</sup> /rev [0.87 in <sup>3</sup> /rev]
17	17.0cm <sup>3</sup> /rev [1.04 in <sup>3</sup> /rev]
19	19.0cm <sup>3</sup> /rev [1.16 in <sup>3</sup> /rev]
21	20.5cm <sup>3</sup> /rev [1.25 in <sup>3</sup> /rev]
23	22.5cm <sup>3</sup> /rev [1.37 in <sup>3</sup> /rev]
25	25.4cm <sup>3</sup> /rev [1.55 in <sup>3</sup> /rev]
29	29.0cm <sup>3</sup> /rev [1.77 in <sup>3</sup> /rev]
32	31.8cm <sup>3</sup> /rev [1.94 in <sup>3</sup> /rev]
36	36.1cm <sup>3</sup> /rev [2.20 in <sup>3</sup> /rev]
38	38.0cm <sup>3</sup> /rev [2.32 in <sup>3</sup> /rev]
41	41.0cm <sup>3</sup> /rev [2.50 in <sup>3</sup> /rev]
45	45.1cm <sup>3</sup> /rev [2.75 in <sup>3</sup> /rev]

### B2 Input shaft

A			B1	B2		C	R	S	D	E	F	H	J	K
D	E	2		•	•									

Code	Description
SE*	SAE 9 tooth spline, 31.8 mm [1.25 in] length
SC	SAE 11 tooth spline, 38.1 mm [1.50 in] length
SF	11 tooth spline, 31.8 mm [1.25 in] length (special modified length)
SH	SAE 13 tooth spline, 41 mm [1.62 in] length
SV	15 tooth spline, 46 mm [1.81 in] length (requires mounting flange AR or BR)
PB	22 mm [7/8 in] diameter x 41 mm [1.62 in] length, with 1/4 inch key
PD	19 mm [3/4 in] diameter x 51 mm [2.0 in] length, with 3/16 inch key
PZ	25.4 mm [1 inch] diameter x 46 mm [1.81 in] length, with 1/4 inch key
TA	1:5taper, 25mm [1 in] dia, 58mm [2.30 in] length, 5/8 thread, M5 key with locknut and washer
TG	1:8taper, 22mm [7/8 in] dia, 50mm [1.95 in] length, 5/8 thread with key, locknut and washer
TH	1:8taper, 22mm [7/8 in] dia, 49mm [1.94 in] length, 9/16 thread with key, locknut and washer
WT	Input shaft similar to TH option with 34 tooth helical gear for Perkins engine mount

\* Contact factory for units with SE (9T spline) to verify torque limits



## D Series Model Code

### C Mounting flange

A			B1	B2	C	R	S	D			E	F	H	J	K
D	E	2			• •										

Code	Description
AA	SAE A 2-bolt
AC	SAE A 2-bolt, use with integral PFD/Steering Cover
AM	SAE A 2-bolt, with T seal
AP	SAE A 2-bolt, with T seal, use with integral PFD/Steering cover
AR	SAE A 2-bolt, use with 15 T spline input drive
AS	SAE A 2-bolt, use with integral PFD/Steering cover and 15 T input spline
AL	SAE A 2-bolt, two shaft seals with weep hole
AT	SAE A 2-bolt, two shaft seals with weep hole, use with integral PFD/Steering cover
BB	SAE B 2-bolt
BC	SAE B 2-bolt, use with integral PFD/Steering cover
BM	SAE B 2-bolt, with T seal
BP	SAE B 2-bolt, with T seal, use with integral PFD/Steering cover
BR	SAE B 2-bolt, use with 15 T spline input drive
BS	SAE B 2-bolt, use with integral PFD/Steering cover and 15 T input spline
BT	SAE B 2-bolt, two shaft seals with weep hole, use with integral PFD/Steering Cover
BW	SAE B 2-bolt, two shaft seals with weep hole
PP	Perkins 6 bolt flange with (2) seals (use with WT input shaft and clockwise rotation)

### R Ports - First section

A			B1	B2	C	R	S	D			E	F	H	J	K
D	E	2				• • •									

Code	Description
101	1 1/16-12 side inlet, 7/8-14 side outlet
103	1 5/16-12 side inlet, 7/8-14 side outlet
104	1 5/16-12 side inlet, 1 1/16-12 side outlet
113	No inlet, 7/8-14 side outlet
125	1 5/8-12 side inlet, 1 1/16-12 side outlet
126	No inlet, 1 1/16-12 side outlet
341	No inlet, 3/4 side split flange outlet (SAE Code 61)
342	1 1/4 side split flange inlet, 3/4 side split flange outlet (SAE Code 61)

SAE O-ring boss ports No integrated valves

SAE Split Flange Ports - No integrated valves

**D Series Model Code**

Code	Description	
401	No inlet, 1/2-14 side outlet	British Standard Pipe Parallel (BSPP) threads - No integrated valves
402	3/4-14 side inlet, 1/2-14 side outlet	
403	1-11 side inlet, 1/2-14 side outlet	
404	1 1/4-11 side inlet, 1/2-14 side outlet	
405	No inlet, 3/4-14 side outlet	
407	1-11 side inlet, 3/4-14 side outlet	
408	1 1/4-11 side inlet, 3/4-14 side outlet	
704	1 1/4 side tube inlet, 7/8-14 side ORB outlet	
708	11/4 side tube inlet, 1 1/16-12 side ORB outlet	
716	11/2 side tube inlet, 1 1/16-12 side ORB outlet	
717	1 1/2 side tube inlet, 7/8-14 side ORB outlet	

**S Displacement - Second section**

A			B1	B2	C	R	S	D			E	F	H	J	K	
D	E	2					•	•								

Code	Description
07	7.0 cm <sup>3</sup> /rev [0.43 in <sup>3</sup> /rev]
10	9.5 cm <sup>3</sup> /rev [0.58 in <sup>3</sup> /rev]
11	10.8cm <sup>3</sup> /rev [0.66 in <sup>3</sup> /rev]
13	12.6cm <sup>3</sup> /rev [0.77 in <sup>3</sup> /rev]
14	14.3cm <sup>3</sup> /rev [0.87 in <sup>3</sup> /rev]
17	17.0cm <sup>3</sup> /rev [1.04 in <sup>3</sup> /rev]
19	19.0cm <sup>3</sup> /rev [1.16 in <sup>3</sup> /rev]
21	20.5 cm <sup>3</sup> /rev [1.25 in <sup>3</sup> /rev]
23	22.5 cm <sup>3</sup> /rev [1.37 in <sup>3</sup> /rev]
25	25.4 cm <sup>3</sup> /rev [1.55 in <sup>3</sup> /rev]
29	29.0 cm <sup>3</sup> /rev [1.77 in <sup>3</sup> /rev]
32	31.8 cm <sup>3</sup> /rev [1.94 in <sup>3</sup> /rev]
36	36.1 cm <sup>3</sup> /rev [2.20 in <sup>3</sup> /rev]
38	38.0 cm <sup>3</sup> /rev [2.32 in <sup>3</sup> /rev]
41	41.0 cm <sup>3</sup> /rev [2.50 in <sup>3</sup> /rev]
45	45.1 cm <sup>3</sup> /rev [2.75 in <sup>3</sup> /rev]

**D Rear cover: Port options, integrated valves and auxillary flange**

A			B1	B2	C	R	S	D				E	F	H	J	K
D	E	2						•	•	•	•					

**D Series Model Code**

Code	Inlet	Outlet	Description
<b>N101</b>	1 1/16-12 side inlet	7/8-14 side outlet	SAE O-ring boss ports No integrated valves No auxiliary flange
<b>N103</b>	1 5/16-12 side inlet	7/8-14 side outlet	
<b>N104</b>	1 5/16-12 side inlet	1 1/16-12 side outlet	
<b>N113</b>	No inlet	7/8-14 side outlet	
<b>N125</b>	1 5/8-12 side inlet	1 1/16-12 side outlet	
<b>N126</b>	No inlet	1 1/16-12 side outlet	
<b>N501</b>	1 1/16-12 rear inlet	7/8-14 rear outlet	
<b>N503</b>	1 5/16-12 rear inlet	7/8-14 rear outlet	
<b>N504</b>	1 5/16-12 rear inlet	1 1/16-12 rear outlet	
<b>N401</b>	No inlet	1/2-14 side outlet	
<b>N402</b>	3/4-14 side inlet	1/2-14 side outlet	
<b>N403</b>	1-11 side inlet	1/2-14 side outlet	
<b>N404</b>	1 1/4-11 side inlet	1/2-14 side outlet	
<b>N407</b>	1-11 side inlet	3/4-14 side outlet	
<b>N408</b>	1 1/4-11 side inlet	3/4-14 side outlet	
<b>N341</b>	No inlet	3/4side split flange outlet (SAE code 61)	SAE split flange ports No integrated valves No auxiliary flange
<b>N342</b>	1 1/4 side split flange inlet	3/4side split flange outlet (SAE code 61)	
<b>N704</b>	1 1/4 side tube inlet	7/8-14 side ORB outlet	Beaded tube inlet port, SAE O-ring boss outlet port No integrated valves No auxiliary flange
<b>N708</b>	1 1/4 side tube inlet	1 1/16-12 side ORB outlet	
<b>N715</b>	1 1/4 REAR tube inlet	1 1/16-12 REAR ORB outlet	
<b>N716</b>	1 1/2 side tube inlet	1 1/16-12 side ORB outlet	
<b>N720</b>	1 1/4 REAR tube inlet	7/8-14 REAR ORB outlet	
<b>B103*</b>	1 5/16-12 side inlet	7/8-14 side outlet,	SAE-A2-Bolt Auxiliary Flange SAE O-ring boss ports No integrated valves
<b>B104*</b>	1 5/16-12 side inlet	1 1/16-12 side outlet	Integrated Relief Valve Internally Drained Maximum Displacement 23cc
<b>R104</b>	1 5/16-12 side inlet	1 1/16-12 side outlet	
<b>N252</b>	M33x2-6H rear inlet	M22x1.5-6H side outlet	SAE Metric Ports – No Integrated Valves

\* Integrated auxiliary flange requires use of input shaft option AH or AC

**D Series Model Code**

Code	Inlet/Outlet	Description
<b>F09A**</b>	15/16-12 side inlet, 3/4-16 side priority, 7/8-14 side secondary (SAE A flange)	Integrated Priority Flow Divider, cartridge style relief for settings up to: 221 bar and 34.3 l/min [3200 psi and 9 US gal/min]
<b>F09B‡</b>	15/16-12 side inlet, 3/4-16 side priority, 7/8-14 side secondary (SAE B flange)	
<b>F13A**</b>	1 5/8-12 rear inlet, 3/4-16 rear priority, 7/8-14 rear secondary (SAE A flange)	
<b>F13B‡</b>	1 5/8-12 rear inlet, 3/4-16 rear priority, 7/8-14 rear secondary (SAE B flange)	
<b>F21A**</b>	15/8-12 side inlet, 3/4-16 side priority, 7/8-14 side secondary (SAE A flange)	
<b>F21B‡</b>	15/8-12 side inlet, 3/4-16 side priority, 7/8-14 side secondary (SAE B flange)	
<b>F25A**</b>	1 5/16-12 rear inlet, 3/4-16 rear priority, 7/8-14 rear secondary (SAE A flange)	
<b>F25B‡</b>	1 5/16-12 rear inlet, 3/4-16 rear priority, 7/8-14 rear secondary (SAE B flange)	
<b>D23A*</b>	15/16-12 side inlet, 3/4-16 side priority, no secondary port (SAE A flange)	Integrated Steering Cover, Priority Relief Valve (Cartridge Style) for settings up to: 221 bar and 34.3 l/min [3200 psi and 9 US gal/min]
<b>D23B**</b>	15/16-12 side inlet, 3/4-16 side priority, no secondary port (SAE B flange)	
<b>D24A*</b>	1 5/16-12 rear inlet, 3/4-16 rear priority, no secondary port (SAE A flange)	
<b>D24B**</b>	1 5/16-12 rear inlet, 3/4-16 rear priority, no secondary port (SAE B flange)	
<b>L01A**</b>	1 5/16-12 side inlet, 3/4-16 side priority, 7/8-14 side secondary, 7/16-20 side LS (SAE-A flange)	Integrated Load Sense Divider (Dynamic), Priority Relief Valve
<b>L01B***</b>	1 5/16-12 side inlet, 3/4-16 side priority, 7/8-14 side secondary, 7/16-20 side LS (SAE-B flange)	
<b>L08A**</b>	1 5/16-12 rear inlet, 3/4-16 rear priority, 7/8-14 rear secondary, 7/16-20 rear LS (SAE-A flange)	
<b>L08B***</b>	1 5/16-12 rear inlet, 3/4-16 rear priority, 7/8-14 rear secondary, 7/16-20 rear LS (SAE-B flange)	

\*\* Requires use of mounting flange option AC or AP

‡ Requires use of mounting flange option BC or BP

\* Integrated auxilliary flange requires use of input shaft option AH or AC

[A variety of integrated valve options including PFD, Steering Covers, and Load sense priority flow dividers covers are available with D Series multiple pumps. Please contact your technical representative to determine which hardware best suits specific application needs.](#)

**E Flow control valve**

A			B1	B2	C	R	S	D	E	F	H	J	K
D	E	2							•	•	•		

**D Series Model Code**

Code	Description	
<b>NNN</b>	Noflow control setting, standard for units without integrated flow control valves	
<b>04X</b>	3.8 l/min [1 US gal/min]	For integrated PFD Steering cover with cartridge style relief valve (Cover options F09A, F09B, F13A, F13B, F21A, F21B, F25A or F25B)
<b>08X</b>	7.6 l/min [2 US gal/min]	
<b>11X</b>	11.4 l/min [3 US gal/min]	
<b>15X</b>	15.1 l/min [4 US gal/min]	
<b>19X</b>	18.9 l/min [5 US gal/min]	
<b>23X</b>	22.7 l/min [6 US gal/min]	
<b>27X</b>	26.5 l/min [7 US gal/min]	
<b>30X</b>	30.3 l/min [8 US gal/min]	
<b>34X</b>	34.3 l/min [9 US gal/min]	
<b>38A</b>	10 bar standby	Forintegrated load sense divider (use with L08A or L08B rear ports)
<b>38L</b>	10 bar standby	Forintegrated load sense divider (use with L01A or L01B side ports)
<b>R1N</b>	Maximum flow not to exceed 75 l/min, pressure range from 7-55bar	For integrated relief valve, internally drained (without flow control) Use with R104 cover option 23cc and under
<b>R2N</b>	Maximum flow not to exceed 75 l/min, pressure range from 41-248bar	For integrated relief valve, internally drained (without flow control) Use with R104 cover option 23cc and under

**F Pressure control valve**

A		B1	B2	C	R	S	D		E	F			H	J	K
D	E	2									•	•	•		

**D Series Model Code**

Code	Description	
000	Nopressure control settings	
034	34 bar [500 psi]	<p>For integrated priority flow divider (PFD) cover with cartridge style relief valve (Cover options F09A, F09B, F13A, F13B, F21A, F21B, F25A, F25B)</p> <p>For integrated steering cover with cartridge style relief valve (Cover options D23A, D23B, D24A, D24B)</p> <p>For integrated load sense (LS) cover with cartridge relief valve (Cover options L01A, L01B, L08A, L08B)</p>
041	41 bar [600 psi]	
048	48 bar [700 psi]	
055	55 bar [800 psi]	
062	62 bar [900 psi]	
069	69 bar [1000 psi]	
076	76 bar [1100 psi]	
083	83 bar [1200 psi]	
090	90 bar [1300 psi]	
097	97 bar [1400 psi]	
103	103 bar [1500 psi]	
110	110 bar [1600 psi]	
117	117 bar [1700 psi]	
124	124 bar [1800 psi]	
131	131 bar [1900 psi]	
138	138 bar [2000 psi]	
145	145 bar [2100 psi]	
152	152 bar [2200 psi]	
159	159 bar [2300 psi]	
165	165 bar [2400 psi]	
172	172 bar [2500 psi]	
179	179 bar [2600 psi]	
186	186 bar [2700 psi]	
193	193 bar [2800 psi]	
200	200 bar [2900 psi]	
207	207 bar [3000 psi]	
214	214 bar [3100 psi]	
221	221 bar [3200 psi]	

**H Assembly screws**

A	B1	B2	C	R	S	D	E	F	H	J	K
D	E	2							•	•	

1. Step 1 - Select the table corresponding to the port codes of the front and rear pump
2. Step 2 - Select the row corresponding to the displacement of the front pump
3. Step 3 - Select the column corresponding to the displacement of the rear pump
4. Step 4 - Select the 2 letter code where the two displacements meet

Example from Table 1: AW = 21+19 tandem

The following tables are only applicable to port codes shown. For all other port code options (including PFD, LS and auxiliary cover), please consult factory.

### D Series Model Code

Table number	Front pump port code Module R	Rear pump port code Module D
1	101, 103, 104, 113, 126, 704 or 708	N101, N103, N104, N113, N126, N501, N503, N504, N704, or N708
2	125, 716, 717	N101, N103, N104, N113, N126, N501, N503, N504, N704, or N708
3	101, 103, 104, 113, 126, 704 or 708	N125
4	125, 716, 717	N125

Table 1	Frontpump port code, Module: R = 101, 103, 104, 113, 126, 704, or 708 Rearpump port code, Module: D = N101, N103, N104, N113, N126, N501, N503, N504, N704, or N708														
Displacement front pump (Module B)	Displacement rear pump, Module: S														
	07	10	13	14	17	19	21	23	25	29	32	36	38	41	45
07	AS	AS	AS	AT	AT	AT	AU	AU	AU	AV	AV	AW	AW	AX	AY
10	AS	AS	AT	AT	AU	AU	AU	AU	AV	AV	AW	AX	AX	AX	AY
13	AS	AT	AT	AU	AU	AU	AV	AV	AV	AW	AW	AX	AX	AY	AY
14	AT	AT	AU	AU	AU	AV	AV	AV	AW	AW	AX	AX	AY	AY	AZ
17	AT	AU	AU	AU	AV	AV	AV	AW	AW	AX	AX	AY	AY	AY	AZ
19	AT	AU	AU	AV	AV	AV	AW	AW	AW	AX	AX	AY	AZ	AZ	AZ
21	AU	AU	AV	AV	AV	AW	AW	AW	AX	AX	AY	AY	AZ	AZ	BA
23	AU	AU	AV	AV	AW	AW	AW	AW	AX	AX	AY	AZ	AZ	AZ	BA
25	AU	AV	AV	AW	AW	AW	AX	AX	AX	AY	AZ	AZ	AZ	BA	BA
29	AV	AV	AW	AW	AX	AX	AX	AX	AY	AY	AZ	AZ	BA	BA	BB
32	AV	AW	AW	AX	AX	AX	AY	AY	AY	AZ	AZ	BA	BA	BB	BB
36	AW	AX	AX	AX	AY	AY	AY	AY	AZ	AZ	BA	BA	BB	BB	BC
38	AW	AX	AX	AY	AY	AY	AZ	AZ	AZ	BA	BA	BB	BB	BC	BC
41	AX	AX	AY	AY	AY	AZ	AZ	AZ	BA	BA	BB	BB	BC	BC	BD
45	AY	AY	AY	AZ	AZ	AZ	BA	BA	BA	BB	BB	BC	BC	BD	BE

Table 2	Frontpump port code, Module: R = 125, 716, 717 Rearpump port code, Module: D = N101, N103, N104, N113, N126, N501, N503, N504, N704, or N708														
Displacement front pump (Module B)	Displacement rear pump, Module: S														
	07	10	13	14	17	19	21	23	25	29	32	36	38	41	45
07	AT	AT	AU	AU	AV	AV	AV	AV	AW	AW	AX	AY	AY	AY	AZ
10	AT	AU	AU	AV	AV	AV	AV	AW	AW	AX	AX	AY	AY	AZ	AZ
13	AU	AU	AV	AV	AV	AW	AW	AW	AX	AX	AY	AY	AZ	AZ	BA
14	AU	AV	AV	AV	AW	AW	AW	AX	AX	AY	AY	AZ	AZ	AZ	BA
17	AV	AV	AV	AW	AW	AW	AX	AX	AX	AY	AY	AZ	AZ	BA	BB
19	AV	AV	AW	AW	AW	AX	AX	AX	AY	AY	AZ	AZ	BA	BA	BB
21	AV	AV	AW	AW	AX	AX	AX	AY	AY	AZ	AZ	BA	BA	BA	BB
23	AV	AW	AW	AX	AX	AX	AY	AY	AY	AZ	AZ	BA	BA	BB	BB
25	AW	AW	AX	AX	AX	AY	AY	AY	AZ	AZ	BA	BA	BB	BB	BC

D Series Model Code

<b>Table 2</b>	<b>Frontpump port code, Module: R = 125, 716, 717 Rearpump port code, Module: D = N101, N103, N104, N113, N126, N501, N503, N504, N704, or N708</b>														
<b>Displacement front pump (Module B)</b>	<b>Displacement rear pump, Module: S</b>														
	<b>07</b>	<b>10</b>	<b>13</b>	<b>14</b>	<b>17</b>	<b>19</b>	<b>21</b>	<b>23</b>	<b>25</b>	<b>29</b>	<b>32</b>	<b>36</b>	<b>38</b>	<b>41</b>	<b>45</b>
<b>29</b>	AW	AX	AX	AY	AY	AY	AY	AZ	AZ	BA	BA	BB	BB	BC	BC
<b>32</b>	AX	AX	AY	AY	AY	AZ	AZ	AZ	BA	BA	BB	BB	BC	BC	BD
<b>36</b>	AY	AY	AY	AZ	AZ	AZ	AZ	BA	BA	BB	BB	BC	BC	BD	BE
<b>38</b>	AY	AY	AZ	AZ	AZ	BA	BA	BA	BB	BB	BC	BC	BD	BD	BE
<b>41</b>	AY	AZ	AZ	AZ	BA	BA	BA	BB	BB	BC	BC	BD	BD	BE	BE
<b>45</b>	AZ	AZ	BA	BA	BB	BB	BB	BB	BC	BC	BD	BE	BE	BE	BF

<b>Table 3</b>	<b>Frontpump port code, Module: R = 101, 103, 104, 113, 126, 704, or 708 Rearpump port code, Module: D = N125</b>														
<b>Displacement front pump (Module B)</b>	<b>Displacement rear pump, Module: S</b>														
	<b>07</b>	<b>10</b>	<b>13</b>	<b>14</b>	<b>17</b>	<b>19</b>	<b>21</b>	<b>23</b>	<b>25</b>	<b>29</b>	<b>32</b>	<b>36</b>	<b>38</b>	<b>41</b>	<b>45</b>
<b>07</b>	AU	AU	AV	AV	AW	AW	AW	AW	AX	AX	AY	AZ	AZ	AZ	BA
<b>10</b>	AU	AV	AV	AV	AW	AW	AW	AX	AX	AY	AY	AZ	AZ	AZ	BA
<b>13</b>	AV	AV	AW	AW	AW	AX	AX	AX	AY	AY	AZ	AZ	BA	BA	BB
<b>14</b>	AV	AV	AW	AW	AX	AX	AX	AY	AY	AZ	AZ	BA	BA	BA	BB
<b>17</b>	AW	AW	AW	AX	AX	AX	AY	AY	AY	AZ	AZ	BA	BA	BA	BC
<b>19</b>	AW	AW	AX	AX	AX	AY	AY	AY	AZ	AZ	BA	BA	BB	BB	BC
<b>21</b>	AW	AW	AX	AX	AY	AY	AY	AY	AZ	BA	BA	BB	BB	BB	BC
<b>23</b>	AW	AX	AX	AY	AY	AY	AY	AZ	AZ	BA	BA	BB	BB	BB	BC
<b>25</b>	AX	AX	AY	AY	AY	AZ	AZ	AZ	BA	BA	BB	BB	BC	BC	BD
<b>29</b>	AX	AY	AY	AZ	AZ	AZ	BA	BA	BA	BB	BB	BC	BC	BC	BD
<b>32</b>	AY	AY	AZ	AZ	AZ	BA	BA	BA	BB	BB	BC	BC	BD	BD	BE
<b>36</b>	AZ	AZ	AZ	BA	BA	BA	BB	BB	BB	BC	BC	BD	BD	BD	BF
<b>38</b>	AZ	AZ	BA	BA	BA	BA	BB	BB	BC	BC	BD	BD	BE	BE	BF
<b>41</b>	AZ	BA	BA	BA	BB	BB	BB	BC	BC	BD	BD	BE	BE	BE	BF
<b>45</b>	BA	BA	BB	BB	BC	BC	BC	BC	BD	BD	BE	BF	BF	BF	BG

<b>Table 4</b>	<b>Front pump port code, Module: R = 125, 716, 717 Rear pump port code, Module: D = N125</b>														
<b>Displacement front pump (Module B)</b>	<b>Displacement rear pump, Module: S</b>														
	<b>07</b>	<b>10</b>	<b>13</b>	<b>14</b>	<b>17</b>	<b>19</b>	<b>21</b>	<b>23</b>	<b>25</b>	<b>29</b>	<b>32</b>	<b>36</b>	<b>38</b>	<b>41</b>	<b>45</b>
<b>07</b>	AV	AW	AW	AW	AX	AX	AX	AY	AY	AZ	AZ	BA	BA	BB	BB
<b>10</b>	AW	AW	AX	AX	AX	AY	AY	AY	AZ	AZ	BA	BA	BB	BB	BC
<b>13</b>	AW	AX	AX	AX	AY	AY	AY	AZ	AZ	BA	BA	BB	BB	BC	BC
<b>14</b>	AX	AX	AX	AY	AY	AY	AZ	AZ	AZ	BA	BA	BB	BB	BC	BC
<b>17</b>	AX	AX	AY	AY	AY	AZ	AZ	AZ	BA	BA	BB	BB	BC	BC	BD
<b>19</b>	AX	AY	AY	AY	AZ	AZ	AZ	BA	BA	BB	BB	BC	BC	BD	BD
<b>21</b>	AY	AY	AY	AZ	AZ	AZ	BA	BA	BA	BB	BB	BC	BC	BD	BD
<b>23</b>	AY	AY	AZ	AZ	AZ	BA	BA	BA	BB	BB	BC	BC	BD	BD	BE



### D Series Model Code

Table 4	Front pump port code, Module: R = 125, 716, 717 Rear pump port code, Module: D = N125														
Displacement front pump (Module B)	Displacement rear pump, Module: S														
	07	10	13	14	17	19	21	23	25	29	32	36	38	41	45
25	AY	AZ	AZ	AZ	BA	BA	BA	BB	BB	BC	BC	BD	BD	BE	BE
29	AZ	AZ	BA	BA	BA	BA	BB	BB	BC	BC	BD	BD	BE	BE	BF
32	AZ	BA	BA	BA	BB	BB	BB	BC	BC	BD	BD	BE	BE	BF	BF
36	BA	BA	BB	BB	BB	BB	BC	BC	BD	BD	BE	BE	BF	BF	BG
38	BA	BB	BB	BB	BC	BC	BC	BD	BD	BE	BE	BF	BF	BG	BG
41	BB	BB	BC	BC	BC	BC	BC	BD	BE	BE	BF	BF	BG	BG	BH
45	BB	BC	BC	BC	BD	BD	BD	BE	BE	BF	BF	BG	BG	BH	BH

### J Nameplate

A	B1	B2	C	R	S	D	E	F	H	J	K
D	E	2									
										•	•

Code	Description
AN	Standard nameplate

### K Special features

A	B1	B2	C	R	S	D	E	F	H	J	K
D	E	2									
											• • •

Code	Description
NNN	No special features, standard black paint

### Three section (triple) pump order code

#### Example

The order code below provides an example of a three section (triple) pump with single inlet.

A	B1	B2	C	L	M	R	S	D	E	F	H	J	K																							
D	E	3	R	2	5	S	H	B	B	7	1	6	2	5	1	2	6	2	5	N	1	2	6	N	N	N	0	0	0	B	M	A	N	N	N	N

Code	Position	Description
DE3R	A	D Series pump with three pumping sections, right hand rotation
25	B1	25 cm <sup>3</sup> displacement on first section
SH	B2	13 tooth spline input shaft
BB	C	SAE B two bolt mounting flange
716	L	1 1/2 inch beaded tube inlet, 1 1/16-12 side ORB outlet on first section
25	M	25 cm <sup>3</sup> displacement on second section
126	R	No inlet and 1 1/16-12 side outlet on second section
25	S	25 cm <sup>3</sup> displacement on third section
N126	D	No inlet and 1 1/16-12 side outlet on third section

**D Series Model Code**

Code	Position	
NNN	E	No flow control setting
000	F	No pressure control setting
BM	G	Assembly screws
AN	H	Standard Nameplate
NNN	J	No special features, black paint

**A Rotation - viewed from drive shaft**

A	B1	B2	C	L	M	R	S	D	E	F	H	J	K
D	E	3	•										

Code	Description
L	Lefthand (counterclockwise)
R	Right hand (clockwise)

**B1 Displacement - First section**

A	B1	B2	C	L	M	R	S	D	E	F	H	J	K
D	E	3	•	•									

Code	Description
07	7.0 cm <sup>3</sup> /rev [0.43 in <sup>3</sup> /rev]
10	9.5 cm <sup>3</sup> /rev [0.58 in <sup>3</sup> /rev]
11	10.8 cm <sup>3</sup> /rev [0.66 in <sup>3</sup> /rev]
13	12.6 cm <sup>3</sup> /rev [0.77 in <sup>3</sup> /rev]
14	14.3 cm <sup>3</sup> /rev [0.87 in <sup>3</sup> /rev]
17	17.0 cm <sup>3</sup> /rev [1.04 in <sup>3</sup> /rev]
19	19.0 cm <sup>3</sup> /rev [1.16 in <sup>3</sup> /rev]
21	20.5 cm <sup>3</sup> /rev [1.25 in <sup>3</sup> /rev]
23	22.5 cm <sup>3</sup> /rev [1.37 in <sup>3</sup> /rev]
25	25.4 cm <sup>3</sup> /rev [1.55 in <sup>3</sup> /rev]
29	29.0 cm <sup>3</sup> /rev [1.77 in <sup>3</sup> /rev]
32	31.8 cm <sup>3</sup> /rev [1.94 in <sup>3</sup> /rev]
36	36.1 cm <sup>3</sup> /rev [2.20 in <sup>3</sup> /rev]
38	38.0 cm <sup>3</sup> /rev [2.32 in <sup>3</sup> /rev]
41	41.0 cm <sup>3</sup> /rev [2.50 in <sup>3</sup> /rev]
45	45.1 cm <sup>3</sup> /rev [2.75 in <sup>3</sup> /rev]

**B2 Input shaft**

A	B1	B2	C	L	M	R	S	D	E	F	H	J	K
D	E	3	•	•									

### D Series Model Code

Code	Description
SE*	SAE 9 tooth spline, 31.8 mm [1.25 in] length
SC	SAE 11 tooth spline, 38.1 mm [1.50 in] length
SF	11 tooth spline, 31.8 mm [1.25 in] length (special modified length)
SH	SAE 13 tooth spline, 41 mm [1.62 in] length
SV	15 tooth spline, 46 mm [1.81 in] length (requires mounting flange AR or BR)
PB	22 mm [7/8 in] diameter x 41 mm [1.62 in] length, with 1/4 inch key
PD	19 mm [3/4 in] diameter x 51 mm [2.0 in] length, with 3/16 inch key
PZ	25.4 mm [1 inch] diameter x 46 mm [1.81 in] length, with 1/4 inch key
TA	1:5taper, 25mm [1 in] dia, 58mm [2.30 in] length, 5/8 thread, M5 key with locknut and washer
TG	1:8taper, 22mm [7/8 in] dia, 50mm [1.95 in] length, 5/8 thread with key, locknut and washer
TH	1:8taper, 22mm [7/8 in] dia, 49mm [1.94 in] length, 9/16 thread with key, locknut and washer
WT	Input shaft similar to TH option with 34 tooth helical gear for Perkins engine mount

\* Contact factory for units with SE (9T spline) to verify torque limits

### C Mounting flange

A			B1	B2	C	L	M	R	S	D	E	F	H	J	K	
D	E	3			• •											

Code	Description
AA	SAE A 2-bolt
AC	SAE A 2-bolt, use with integral PFD/Steering Cover
AM	SAE A 2-bolt, with T seal
AP	SAE A 2-bolt, with T seal, use with integral PFD/Steering cover
AR	SAE A 2-bolt, use with 15 T spline input drive
AS	SAE A 2-bolt, use with integral PFD/Steering cover and 15 T input spline
AL	SAE A 2-bolt, two shaft seals with weep hole
AT	SAE A 2-bolt, two shaft seals with weep hole, use with integral PFD/Steering cover
BB	SAE B 2-bolt
BC	SAE B 2-bolt, use with integral PFD/Steering cover
BM	SAE B 2-bolt, with T seal
BP	SAE B 2-bolt, with T seal, use with integral PFD/Steering cover
BR	SAE B 2-bolt, use with 15 T spline input drive
BS	SAE B 2-bolt, use with integral PFD/Steering cover and 15 T input spline
BT	SAE B 2-bolt, two shaft seals with weep hole, use with integral PFD/Steering Cover
BW	SAE B 2-bolt, two shaft seals with weep hole
PP	Perkins 6 bolt flange with (2) seals (use with WT input shaft and clockwise rotation)

### L Ports - First section

A			B1	B2	C	L	M	R	S	D	E	F	H	J	K
D	E	3				• • •									

**D Series Model Code**

Code	Description	
101	1 1/16-12 side inlet, 7/8-14 side outlet	SAE O-ring boss ports No integrated valves
103	1 5/16-12 side inlet, 7/8-14 side outlet	
104	1 5/16-12 side inlet, 1 1/16-12 side outlet	
113	No inlet, 7/8-14 side outlet	
125	1 5/8-12 side inlet, 1 1/16-12 side outlet	
126	No inlet, 1 1/16-12 side outlet	
341	No inlet, 3/4 side split flange outlet (SAE Code 61)	SAE Split Flange Ports - No integrated valves
342	1 1/4 side split flange inlet, 3/4 side split flange outlet (SAE Code 61)	
401	No inlet, 1/2-14 side outlet	British Standard Pipe Parallel (BSPP) threads - No integrated valves
402	3/4-14 side inlet, 1/2-14 side outlet	
403	1-11 side inlet, 1/2-14 side outlet	
404	1 1/4-11 side inlet, 1/2-14 side outlet	
405	No inlet, 3/4-14 side outlet	
407	1-11 side inlet, 3/4-14 side outlet	
408	1 1/4-11 side inlet, 3/4-14 side outlet	
704	1 1/4 side tube inlet, 7/8-14 side ORB outlet	
708	1 1/4 side tube inlet, 1 1/16-12 side ORB outlet	
716	1 1/2 side tube inlet, 1 1/16-12 side ORB outlet	
717	1 1/2 side tube inlet, 7/8-14 side ORB outlet	

**M Displacement - Second section**

A	B1	B2	C	L	M	R	S	D	E	F	H	J	K
D	E	3				•	•						

Code	Description
07	7.0 cm <sup>3</sup> /rev [0.43 in <sup>3</sup> /rev]
10	9.5 cm <sup>3</sup> /rev [0.58 in <sup>3</sup> /rev]
11	10.8 cm <sup>3</sup> /rev [0.66 in <sup>3</sup> /rev]
13	12.6 cm <sup>3</sup> /rev [0.77 in <sup>3</sup> /rev]
14	14.3 cm <sup>3</sup> /rev [0.87 in <sup>3</sup> /rev]
17	17.0 cm <sup>3</sup> /rev [1.04 in <sup>3</sup> /rev]
19	19.0 cm <sup>3</sup> /rev [1.16 in <sup>3</sup> /rev]
21	20.5 cm <sup>3</sup> /rev [1.25 in <sup>3</sup> /rev]
23	22.5 cm <sup>3</sup> /rev [1.37 in <sup>3</sup> /rev]
25	25.4 cm <sup>3</sup> /rev [1.55 in <sup>3</sup> /rev]
29	29.0 cm <sup>3</sup> /rev [1.77 in <sup>3</sup> /rev]
32	31.8 cm <sup>3</sup> /rev [1.94 in <sup>3</sup> /rev]
36	36.1 cm <sup>3</sup> /rev [2.20 in <sup>3</sup> /rev]
38	38.0 cm <sup>3</sup> /rev [2.32 in <sup>3</sup> /rev]

### D Series Model Code

Code	Description
41	41.0 cm <sup>3</sup> /rev [2.50 in <sup>3</sup> /rev]
45	45.1 cm <sup>3</sup> /rev [2.75 in <sup>3</sup> /rev]

### R Ports - Second section

A	B1	B2	C	L	M	R	S	D	E	F	H	J	K
D	E	3					•	•					

Code	Description
101	1 1/16-12 side inlet, 7/8-14 side outlet
103	1 5/16-12 side inlet, 7/8-14 side outlet
104	1 5/16-12 side inlet, 1 1/16-12 side outlet
113	No inlet, 7/8-14 side outlet
125	1 5/8-12 side inlet, 1 1/16-12 side outlet
126	No inlet, 1 1/16-12 side outlet
341	No inlet, 3/4 side split flange outlet (SAE Code 61)
342	1 1/4 side split flange inlet, 3/4 side split flange outlet (SAE Code 61)
401	No inlet, 1/2-14 side outlet
402	3/4-14 side inlet, 1/2-14 side outlet
403	1-11 side inlet, 1/2-14 side outlet
404	1 1/4-11 side inlet, 1/2-14 side outlet
405	No inlet, 3/4-14 side outlet
407	1-11 side inlet, 3/4-14 side outlet
408	1 1/4-11 side inlet, 3/4-14 side outlet
704	1 1/4 side tube inlet, 7/8-14 side ORB outlet
708	1 1/4 side tube inlet, 1 1/16-12 side ORB outlet
716	1 1/2 side tube inlet, 1 1/16-12 side ORB outlet
717	1 1/2 side tube inlet, 7/8-14 side ORB outlet

### S Displacement - Third section

A	B1	B2	C	L	M	R	S	D	E	F	H	J	K
D	E	3					•	•					

Code	Description
07	7.0 cm <sup>3</sup> /rev [0.43 in <sup>3</sup> /rev]
10	9.5 cm <sup>3</sup> /rev [0.58 in <sup>3</sup> /rev]
11	10.8 cm <sup>3</sup> /rev [0.66 in <sup>3</sup> /rev]
13	12.6 cm <sup>3</sup> /rev [0.77 in <sup>3</sup> /rev]
14	14.3 cm <sup>3</sup> /rev [0.87 in <sup>3</sup> /rev]
17	17.0 cm <sup>3</sup> /rev [1.04 in <sup>3</sup> /rev]
19	19.0 cm <sup>3</sup> /rev [1.16 in <sup>3</sup> /rev]
21	20.5 cm <sup>3</sup> /rev [1.25 in <sup>3</sup> /rev]

### D Series Model Code

Code	Description
23	22.5cm <sup>3</sup> /rev [1.37 in <sup>3</sup> /rev]
25	25.4cm <sup>3</sup> /rev [1.55 in <sup>3</sup> /rev]
29	29.0cm <sup>3</sup> /rev [1.77 in <sup>3</sup> /rev]
32	31.8cm <sup>3</sup> /rev [1.94 in <sup>3</sup> /rev]
36	36.1cm <sup>3</sup> /rev [2.20 in <sup>3</sup> /rev]
38	38.0cm <sup>3</sup> /rev [2.32 in <sup>3</sup> /rev]
41	41.0cm <sup>3</sup> /rev [2.50 in <sup>3</sup> /rev]
45	45.1cm <sup>3</sup> /rev [2.75 in <sup>3</sup> /rev]

### D Rear cover: Port options, integrated valves and auxiliary

A	B1	B2	C	L	M	R	S	D	E	F	H	J	K
D	E	3						•	•	•	•		

Code	Inlet	Outlet	Description
N101	1 1/16-12 side inlet	7/8-14 side outlet	SAE O-ring boss ports No integrated valves No auxiliary flange
N103	1 5/16-12 side inlet	7/8-14 side outlet	
N104	1 5/16-12 side inlet	1 1/16-12 side outlet	
N125	1 5/8-12 side inlet	1 1/16-12 side outlet	
N126	No inlet	1 1/16-12 side outlet	
N501	1 1/16-12 rear inlet	7/8-14 rear outlet	SAE Metric Ports – No Integrated Valves
N503	1 5/16-12 rear inlet	7/8-14 rear outlet	
N504	1 5/16-12 rear inlet	1 1/16-12 rear outlet	
N252	M33x2-6H rear inlet	M22x1.5-6H side outlet	
N254	M33x2-6H rear inlet	M22x1.5-6H side outlet	British Standard Pipe Parallel (BSPP) threads - No integrated valves
N401	No inlet	1/2-14 side outlet	
N402	3/4-14 side inlet	1/2-14 side outlet	
N403	1-11 side inlet	1/2-14 side outlet	
N404	1 1/4-11 side inlet	1/2-14 side outlet	
N407	1-11 side inlet	3/4-14 side outlet	
N408	1 1/4-11 side inlet	3/4-14 side outlet	SAE split flange ports No integrated valves No auxiliary flange
N341	No inlet	3/4 side split flange outlet (SAE code 61)	
N342	1 1/4 side split flange inlet	3/4 side split flange outlet (SAE code 61)	Beaded tube inlet port, SAE O-ring boss outlet port No integrated valves No auxiliary flange
N704	1 1/4 side tube inlet	7/8-14 side ORB outlet	
N708	1 1/4 side tube inlet	1 1/16-12 side ORB outlet	
N715	1 1/4 REAR tube inlet	1 1/16-12 REAR ORB outlet	
N716	1 1/2 side tube inlet	1 1/16-12 side ORB outlet	
N720	1 1/4 REAR tube inlet	7/8-14 REAR ORB outlet	

**D Series Model Code**

Code	Inlet	Description	
<b>F09A**</b>	15/16-12 side inlet, 3/4-16 side priority, 7/8-14 side secondary (SAE A flange)	Integrated Priority Flow Divider, cartridge style relief for settings up to: 221 bar and 34.3 l/min [3200psi and 9 US gal/min]	
<b>F09B‡</b>	15/16-12 side inlet, 3/4-16 side priority, 7/8-14 side secondary (SAE B flange)		
<b>F13A**</b>	1 5/8-12 rear inlet, 3/4-16 rear priority, 7/8-14 rear secondary (SAE A flange)		
<b>F13B‡</b>	1 5/8-12 rear inlet, 3/4-16 rear priority, 7/8-14 rear secondary (SAE B flange)		
<b>F21A**</b>	15/8-12 side inlet, 3/4-16 side priority, 7/8-14 side secondary (SAE A flange)		
<b>F21B‡</b>	15/8-12 side inlet, 3/4-16 side priority, 7/8-14 side secondary (SAE B flange)		
<b>F25A**</b>	1 5/16-12 rear inlet, 3/4-16 rear priority, 7/8-14 rear secondary (SAE A flange)		
<b>F25B‡</b>	1 5/16-12 rear inlet, 3/4-16 rear priority, 7/8-14 rear secondary (SAE B flange)		
<b>D23A*</b>	15/16-12 side inlet, 3/4-16 side priority, no secondary port (SAE A flange)	Integrated Steering Cover, Priority Relief Valve (Cartridge Style) for settings up to: 221 bar and 34.3 l/min [3200psi and 9 US gal/min]	
<b>D23B**</b>	15/16-12 side inlet, 3/4-16 side priority, no secondary port (SAE B flange)		
<b>D24A*</b>	1 5/16-12 rear inlet, 3/4-16 rear priority, no secondary port (SAE A flange)		
<b>D24B**</b>	1 5/16-12 rear inlet, 3/4-16 rear priority, no secondary port (SAE B flange)		
<b>L01A**</b>	1 5/16-12 side inlet, 3/4-16 side priority, 7/8-14 side secondary, 7/16-20 side LS (SAE-A flange)	Integrated Load Sense Divider (Dynamic), Priority Relief Valve	
<b>L01B‡</b>	1 5/16-12 side inlet, 3/4-16 side priority, 7/8-14 side secondary, 7/16-20 side LS (SAE-B flange)		
<b>L08A**</b>	1 5/16-12 rear inlet, 3/4-16 rear priority, 7/8-14 rear secondary, 7/16-20 rear LS (SAE-A flange)		
<b>L08B‡</b>	1 5/16-12 rear inlet, 3/4-16 rear priority, 7/8-14 rear secondary, 7/16-20 rear LS (SAE-B flange)		
<b>B103*</b>	1 5/16-12 side inlet	7/8-14 side outlet,	SAE-A2-Bolt Auxiliary Flange SAE O-ring boss ports No integrated valves
<b>B104*</b>	1 5/16-12 side inlet	11/16-12 side outlet	
<b>R104</b>	1 5/16-12 side inlet	11/16-12 side outlet	Integrated Relief Valve Internally Drained Maximum Displacement 23cc

\*\* Requires use of mounting flange option AC or AP

‡ Requires use of mounting flange option BC or BP

\* Integrated auxiliary flange requires use of input shaft option AH or AC

[A variety of integrated valve options including PFD, Steering Covers, and Load sense priority flow dividers covers are available with D Series multiple pumps. Please contact your technical representative to determine which hardware best suits specific application needs.](#)

**D Series Model Code**
**E Flow control valve**

A	B1	B2	C	L	M	R	S	D	E	F	H	J	K
D	E	3							•	•	•		

Code	Description	
<b>NNN</b>	No flow control setting, standard for units without integrated flow control valves	
<b>04X</b>	3.8 l/min [1 US gal/min]	For integrated PFD Steering cover with cartridge style relief valve (Cover options F09A, F09B, F13A, F13B, F21A, F21B, F25A or F25B)
<b>08X</b>	7.6 l/min [2 US gal/min]	
<b>11X</b>	11.4 l/min [3 US gal/min]	
<b>15X</b>	15.1 l/min [4 US gal/min]	
<b>19X</b>	18.9 l/min [5 US gal/min]	
<b>23X</b>	22.7 l/min [6 US gal/min]	
<b>27X</b>	26.5 l/min [7 US gal/min]	
<b>30X</b>	30.3 l/min [8 US gal/min]	
<b>34X</b>	34.3 l/min [9 US gal/min]	
<b>38A</b>	10 bar standby	Forintegrated load sense divider (use with L08A or L08B rear ports)
<b>38L</b>	10 bar standby	Forintegrated load sense divider (use with L01A or L01B side ports)
<b>R1N</b>	Maximum flow not to exceed 75 l/min, pressure range from 7-55bar	For integrated relief valve, internally drained (without flow control) Use with R104 cover option 23cc and under
<b>R2N</b>	Maximum flow not to exceed 75 l/min, pressure range from 41-248bar	For integrated relief valve, internally drained (without flow control) Use with R104 cover option 23cc and under

**F Pressure control valve**

A	B1	B2	C	L	M	R	S	D	E	F	H	J	K
D	E	3								•	•	•	



**D Series Model Code**

Code	Description
000	No pressure control settings
034	34 bar [500 psi]
041	41 bar [600 psi]
048	48 bar [700 psi]
055	55 bar [800 psi]
062	62 bar [900 psi]
069	69 bar [1000 psi]
076	76 bar [1100 psi]
083	83 bar [1200 psi]
090	90 bar [1300 psi]
097	97 bar [1400 psi]
103	103 bar [1500 psi]
110	110 bar [1600 psi]
117	117 bar [1700 psi]
124	124 bar [1800 psi]
131	131 bar [1900 psi]
138	138 bar [2000 psi]
145	145 bar [2100 psi]
152	152 bar [2200 psi]
159	159 bar [2300 psi]
165	165 bar [2400 psi]
172	172 bar [2500 psi]
179	179 bar [2600 psi]
186	186 bar [2700 psi]
193	193 bar [2800 psi]
200	200 bar [2900 psi]
207	207 bar [3000 psi]
214	214 bar [3100 psi]
221	221 bar [3200 psi]

Change Description to:  
 For integrated priority flow divider (PFD) cover with cartridge style relief valve  
 (Cover options F09A, F09B, F13A, F13B, F21A, F21B, F25A, F25B)  
 and  
 For integrated steering cover with cartridge style relief valve (Cover options D23A, D23B, D24A, D24B)  
 and  
 For integrated load sense (LS) cover with cartridge relief valve (Cover options L01A, L01B, L08A, L08B)

**H Assembly screws**

A	B1	B2	C	L	M	R	S	D	E	F	H	J	K				
D	E	3										•	•				

Code	Description
**	Will be assigned by Danfoss upon receipt of order

**J Nameplate**

A	B1	B2	C	L	M	R	S	D	E	F	H	J	K				
D	E	3										•	•				

### D Series Model Code

Code	Description
AN	Standard nameplate

### K Special feature

A	B1	B2	C	L	M	R	S	D	E	F	H	J	K
D	E	3											•••

Code	Description
NNN	No special features, standard black paint

### Four section (quad) pump order code

#### Example

The order code below provides an example of a three section (triple) pump with single inlet.

A	B1	B2	C	L	M	N	P	R	S	D	E	F	H	J	K																										
D	E	4	R	2	5	S	H	B	B	1	0	4	2	3	1	0	4	1	0	1	2	6	1	0	N	1	2	6	N	N	N	0	0	0	B	T	A	N	N	N	N

Code	Position	Description
DE4L	A	D Series pump with four pumping sections, left hand rotation
25	B1	25 cm <sup>3</sup> displacement on first section
SH	B2	13 tooth spline input shaft
BB	C	SAE B two bolt mounting flange
104	L	1 5/16-12 side inlet, 1 1/16-12 side outlet on first section
23	M	23 cm <sup>3</sup> displacement on second section
104	N	1 5/16-12 side inlet, 1 1/16-12 side outlet on second section
10	P	10 cm <sup>3</sup> displacement on third section
126	R	No inlet and 1 1/16-12 side outlet on third section
10	S	10 cm <sup>3</sup> displacement on fourth section
N126	D	No inlet and 1 1/16-12 side outlet on fourth section
NNN	E	No flow control setting
000	F	No pressure control setting
BT	H	Assembly screws
AN	J	Standard nameplate
NNN	K	No special features, black paint

### A Rotation - viewed from drive shaft

A	B1	B2	C	L	M	N	P	R	S	D	E	F	H	J	K
D	E	4	•												

Code	Description
L	Lefthand (counterclockwise)
R	Right hand (clockwise)

## D Series Model Code

### B1 Displacement - First section

A	B1	B2	C	L	M	N	P	R	S	D	E	F	H	J	K
D	E	4	•	•											

Code	Description
07	7.0 cm <sup>3</sup> /rev [0.43 in <sup>3</sup> /rev]
10	9.5 cm <sup>3</sup> /rev [0.58 in <sup>3</sup> /rev]
11	10.8cm <sup>3</sup> /rev [0.66 in <sup>3</sup> /rev]
13	12.6cm <sup>3</sup> /rev [0.77 in <sup>3</sup> /rev]
14	14.3cm <sup>3</sup> /rev [0.87 in <sup>3</sup> /rev]
17	17.0cm <sup>3</sup> /rev [1.04 in <sup>3</sup> /rev]
19	19.0cm <sup>3</sup> /rev [1.16 in <sup>3</sup> /rev]
21	20.5cm <sup>3</sup> /rev [1.25 in <sup>3</sup> /rev]
23	22.5cm <sup>3</sup> /rev [1.37 in <sup>3</sup> /rev]
25	25.4cm <sup>3</sup> /rev [1.55 in <sup>3</sup> /rev]
29	29.0cm <sup>3</sup> /rev [1.77 in <sup>3</sup> /rev]
32	31.8cm <sup>3</sup> /rev [1.94 in <sup>3</sup> /rev]
36	36.1cm <sup>3</sup> /rev [2.20 in <sup>3</sup> /rev]
38	38.0cm <sup>3</sup> /rev [2.32 in <sup>3</sup> /rev]
41	41.0cm <sup>3</sup> /rev [2.50 in <sup>3</sup> /rev]
45	45.1cm <sup>3</sup> /rev [2.75 in <sup>3</sup> /rev]

### B2 Input shaft

A	B1	B2	C	L	M	N	P	R	S	D	E	F	H	J	K
D	E	4	•	•											

Code	Description
SE*	SAE 9 tooth spline, 31.8 mm [1.25 in] length
SC	SAE 11 tooth spline, 38.1 mm [1.50 in] length
SF	11 tooth spline, 31.8 mm [1.25 in] length (special modified length)
SH	SAE 13 tooth spline, 41 mm [1.62 in] length
SV	15 tooth spline, 46 mm [1.81 in] length (requires mounting flange AR or BR)
PB	22 mm [7/8 in] diameter x 41 mm [1.62 in] length, with 1/4 inch key
PD	19 mm [3/4 in] diameter x 51 mm [2.0 in] length, with 3/16 inch key
PZ	25.4 mm [1 inch] diameter x 46 mm [1.81 in] length, with 1/4 inch key
TA	1:5taper, 25mm [1 in] dia, 58mm [2.30 in] length, 5/8 thread, M5 key with locknut and washer
TG	1:8taper, 22mm [7/8 in] dia, 50mm [1.95 in] length, 5/8 thread with key, locknut and washer
TH	1:8taper, 22mm [7/8 in] dia, 49mm [1.94 in] length, 9/16 thread with key, locknut and washer
WT	Input shaft similar to TH option with 34 tooth helical gear for Perkins engine mount

\* Contact factory for units with SE (9T spline) to verify torque limits

## D Series Model Code

### C Mounting flange

A	B1	B2	C	L	M	N	P	R	S	D	E	F	H	J	K
D	E	4	•	•											

Code	Description
AA	SAE A 2-bolt
AC	SAE A 2-bolt, use with integral PFD/Steering Cover
AM	SAE A 2-bolt, with T seal
AP	SAE A 2-bolt, with T seal, use with integral PFD/Steering cover
AR	SAE A 2-bolt, use with 15 T spline input drive
AS	SAE A 2-bolt, use with integral PFD/Steering cover and 15 T input spline
AL	SAE A 2-bolt, two shaft seals with weep hole
AT	SAE A 2-bolt, two shaft seals with weep hole, use with integral PFD/Steering cover
BB	SAE B 2-bolt
BC	SAE B 2-bolt, use with integral PFD/Steering cover
BM	SAE B 2-bolt, with T seal
BP	SAE B 2-bolt, with T seal, use with integral PFD/Steering cover
BR	SAE B 2-bolt, use with 15 T spline input drive
BS	SAE B 2-bolt, use with integral PFD/Steering cover and 15 T input spline
BT	SAE B 2-bolt, two shaft seals with weep hole, use with integral PFD/Steering Cover
BW	SAE B 2-bolt, two shaft seals with weep hole
PP	Perkins 6 bolt flange with (2) seals (use with WT input shaft and clockwise rotation)

### L Ports - First section

A	B1	B2	C	L	M	N	P	R	S	D	E	F	H	J	K
D	E	4		•	•	•									

Code	Description
101	1 1/16-12 side inlet, 7/8-14 side outlet
103	1 5/16-12 side inlet, 7/8-14 side outlet
104	1 5/16-12 side inlet, 1 1/16-12 side outlet
113	No inlet, 7/8-14 side outlet
125	1 5/8-12 side inlet, 1 1/16-12 side outlet
126	No inlet, 1 1/16-12 side outlet
341	No inlet, 3/4 side split flange outlet (SAE Code 61)
342	1 1/4 side split flange inlet, 3/4 side split flange outlet (SAE Code 61)

**D Series Model Code**

Code	Description	
401	No inlet, 1/2-14 side outlet	British Standard Pipe Parallel (BSPP) threads - No integrated valves
402	3/4-14 side inlet, 1/2-14 side outlet	
403	1-11 side inlet, 1/2-14 side outlet	
404	1 1/4-11 side inlet, 1/2-14 side outlet	
405	No inlet, 3/4-14 BSPP side outlet	
407	1-11 side inlet, 3/4-14 side outlet	
408	1 1/4-11 side inlet, 3/4-14 side outlet	
704	1 1/4 side tube inlet, 7/8-14 side ORB outlet	Beaded tube inlet port SAE O-ring boss outlet port No integrated valves
708	1 1/4 side tube inlet, 1 1/16-12 side ORB outlet	
716	1 1/2 side tube inlet, 1 1/16-12 side ORB outlet	
707	1 1/2 side tube inlet, 7/8-14 side ORB outlet	

**M Displacement - Second section**

A	B1	B2	C	L	M	N	P	R	S	D	E	F	H	J	K
D	E	4				•	•								

Code	Description
07	7.0 cm <sup>3</sup> /rev [0.43 in <sup>3</sup> /rev]
10	9.5 cm <sup>3</sup> /rev [0.58 in <sup>3</sup> /rev]
11	10.8 cm <sup>3</sup> /rev [0.66 in <sup>3</sup> /rev]
13	12.6 cm <sup>3</sup> /rev [0.77 in <sup>3</sup> /rev]
14	14.3 cm <sup>3</sup> /rev [0.87 in <sup>3</sup> /rev]
17	17.0 cm <sup>3</sup> /rev [1.04 in <sup>3</sup> /rev]
19	19.0 cm <sup>3</sup> /rev [1.16 in <sup>3</sup> /rev]
21	20.5cm <sup>3</sup> /rev [1.25 in <sup>3</sup> /rev]
25	25.4 cm <sup>3</sup> /rev [1.55 in <sup>3</sup> /rev]
29	29.0 cm <sup>3</sup> /rev [1.77 in <sup>3</sup> /rev]
32	31.8 cm <sup>3</sup> /rev [1.94 in <sup>3</sup> /rev]
36	36.1 cm <sup>3</sup> /rev [2.20 in <sup>3</sup> /rev]
38	38.0 cm <sup>3</sup> /rev [2.32 in <sup>3</sup> /rev]
41	41.0 cm <sup>3</sup> /rev [2.50 in <sup>3</sup> /rev]
45	45.1 cm <sup>3</sup> /rev [2.75 in <sup>3</sup> /rev]

**N Ports - Second section**

A	B1	B2	C	L	M	N	P	R	S	D	E	F	H	J	K
D	E	4				•	•	•							

**D Series Model Code**

Code	Description	
101	1 1/16-12 side inlet, 7/8-14 side outlet	SAE O-ring boss ports No integrated valves
103	1 5/16-12 side inlet, 7/8-14 side outlet	
104	1 5/16-12 side inlet, 1 1/16-12 side outlet	
113	No inlet, 7/8-14 side outlet	
125	1 5/8-12 side inlet, 1 1/16-12 side outlet	
126	No inlet, 1 1/16-12 side outlet	
341	No inlet, 3/4 side split flange outlet (SAE Code 61)	SAE Split Flange Ports - No integrated valves
342	1 1/4 side split flange inlet, 3/4 side split flange outlet (SAE Code 61)	
401	No inlet, 1/2-14 side outlet	British Standard Pipe Parallel (BSPP) threads - No integrated valves
402	3/4-14 side inlet, 1/2-14 side outlet	
403	1-11 side inlet, 1/2-14 side outlet	
404	1 1/4-11 side inlet, 1/2-14 side outlet	
405	No inlet, 3/4-14 BSPP side outlet	
407	1-11 side inlet, 3/4-14 side outlet	
408	1 1/4-11 side inlet, 3/4-14 side outlet	Beaded tube inlet port SAE O-ring boss outlet port No integrated valves
704	1 1/4 side tube inlet, 7/8-14 side ORB outlet	
708	1 1/4 side tube inlet, 1 1/16-12 side ORB outlet	
716	1 1/2 side tube inlet, 1 1/16-12 side ORB outlet	
717	1 1/2 side tube inlet, 7/8-14 side ORB outlet	

**P Displacement - Third section**

A	B1	B2	C	L	M	N	P	R	S	D	E	F	H	J	K
D	E	4					•	•							

Code	Description
07	7.0 cm <sup>3</sup> /rev [0.43 in <sup>3</sup> /rev]
10	9.5 cm <sup>3</sup> /rev [0.58 in <sup>3</sup> /rev]
11	10.8 cm <sup>3</sup> /rev [0.66 in <sup>3</sup> /rev]
13	12.6 cm <sup>3</sup> /rev [0.77 in <sup>3</sup> /rev]
14	14.3 cm <sup>3</sup> /rev [0.87 in <sup>3</sup> /rev]
17	17.0 cm <sup>3</sup> /rev [1.04 in <sup>3</sup> /rev]
19	19.0 cm <sup>3</sup> /rev [1.16 in <sup>3</sup> /rev]
21	20.5 cm <sup>3</sup> /rev [1.25 in <sup>3</sup> /rev]
23	22.5 cm <sup>3</sup> /rev [1.37 in <sup>3</sup> /rev]
25	25.4 cm <sup>3</sup> /rev [1.55 in <sup>3</sup> /rev]
29	29.0 cm <sup>3</sup> /rev [1.77 in <sup>3</sup> /rev]
32	31.8 cm <sup>3</sup> /rev [1.94 in <sup>3</sup> /rev]
36	36.1 cm <sup>3</sup> /rev [2.20 in <sup>3</sup> /rev]
38	38.0 cm <sup>3</sup> /rev [2.32 in <sup>3</sup> /rev]

### D Series Model Code

Code	Description
41	41.0 cm <sup>3</sup> /rev [2.50 in <sup>3</sup> /rev]
45	45.1 cm <sup>3</sup> /rev [2.75 in <sup>3</sup> /rev]

### R Ports - Third Section

A	B1	B2	C	L	M	N	P	R	S	D	E	F	H	J	K
D	E	4						•	•	•					

Code	Description
101	1 1/16-12 side inlet, 7/8-14 side outlet
103	1 5/16-12 side inlet, 7/8-14 side outlet
104	1 5/16-12 side inlet, 1 1/16-12 side outlet
113	No inlet, 7/8-14 side outlet
125	1 5/8-12 side inlet, 1 1/16-12 side outlet
126	No inlet, 1 1/16-12 side outlet
341	No inlet, 3/4 side split flange outlet (SAE Code 61)
342	1 1/4 side split flange inlet, 3/4 side split flange outlet (SAE Code 61)
401	No inlet, 1/2-14 side outlet
402	3/4-14 side inlet, 1/2-14 side outlet
403	1-11 side inlet, 1/2-14 side outlet
404	1 1/4-11 side inlet, 1/2-14 side outlet
405	No inlet, 3/4-14 side outlet
407	1-11 side inlet, 3/4-14 side outlet
408	1 1/4-11 side inlet, 3/4-14 side outlet
704	1 1/4 side tube inlet, 7/8-14 side ORB outlet
708	1 1/4 side tube inlet, 1 1/16-12 side ORB outlet
716	1 1/2 side tube inlet, 1 1/16-12 side ORB outlet
717	1 1/2 side tube inlet, 7/8-14 side ORB outlet

### S Displacement - Fourth section

A	B1	B2	C	L	M	N	P	R	S	D	E	F	H	J	K
D	E	4							•	•					

Code	Description
07	7.0 cm <sup>3</sup> /rev [0.43 in <sup>3</sup> /rev]
10	9.5 cm <sup>3</sup> /rev [0.58 in <sup>3</sup> /rev]
11	10.8 cm <sup>3</sup> /rev [0.66 in <sup>3</sup> /rev]
13	12.6 cm <sup>3</sup> /rev [0.77 in <sup>3</sup> /rev]
14	14.3 cm <sup>3</sup> /rev [0.87 in <sup>3</sup> /rev]
17	17.0 cm <sup>3</sup> /rev [1.04 in <sup>3</sup> /rev]
19	19.0 cm <sup>3</sup> /rev [1.16 in <sup>3</sup> /rev]
21	20.5 cm <sup>3</sup> /rev [1.25 in <sup>3</sup> /rev]

**D Series Model Code**

Code	Description
23	22.5 cm <sup>3</sup> /rev [1.37 in <sup>3</sup> /rev]
25	25.4 cm <sup>3</sup> /rev [1.55 in <sup>3</sup> /rev]
29	29.0 cm <sup>3</sup> /rev [1.77 in <sup>3</sup> /rev]
32	31.8 cm <sup>3</sup> /rev [1.94 in <sup>3</sup> /rev]
36	36.1 cm <sup>3</sup> /rev [2.20 in <sup>3</sup> /rev]
38	38.0 cm <sup>3</sup> /rev [2.32 in <sup>3</sup> /rev]
41	41.0 cm <sup>3</sup> /rev [2.50 in <sup>3</sup> /rev]
45	45.1 cm <sup>3</sup> /rev [2.75 in <sup>3</sup> /rev]

**D Rear cover: Port options, integrated valves and auxiliary flange**

A	B1	B2	C	L	M	N	P	R	S	D	E	F	H	J	K
D	E	4								•	•	•			

Code	Inlet	Outlet	Description
N101	1 1/16-12 side inlet	7/8-14 side outlet	SAE O-ring boss ports No integrated valves No auxiliary flange
N103	1 5/16-12 side inlet	7/8-14 side outlet	
N104	1 5/16-12 side inlet	1 1/16-12 side outlet	
N125	1 5/8-12 side inlet	1 1/16-12 side outlet	
N126	No inlet	1 1/16-12 side outlet	
N501	1 1/16-12 rear inlet	7/8-14 rear outlet	
N503	1 5/16-12 rear inlet	7/8-14 rear outlet	
N504	1 5/16-12 rear inlet	1 1/16-12 rear outlet	
N252	M33x2-6H rear inlet	M22x1.5-6H side outlet	SAE Metric Ports – No Integrated Valves
N254	M33x2-6H rear inlet	M22x1.5-6H side outlet	
N401	No inlet	1/2-14 side outlet	British Standard Pipe Parallel (BSPP) threads - No integrated valves
N402	3/4-14 side inlet	1/2-14 side outlet	
N403	1-11 side inlet	1/2-14 side outlet	
N404	1 1/4-11 side inlet	1/2-14 side outlet	
N407	1-11 side inlet	3/4-14 side outlet	
N408	1 1/4-11 side inlet	3/4-14 side outlet	
N341	No inlet	3/4side split flange outlet (SAE code 61)	SAE split flange ports No integrated valves - No auxiliary flange
N342	1 1/4 side split flange inlet	3/4side split flange outlet (SAE code 61)	
N704	1 1/4 side tube inlet	7/8-14 side ORB outlet	Beaded tube inlet port, SAE O-ring boss outlet port No integrated valves No auxiliary flange
N708	1 1/4 side tube inlet	1 1/16-12 side ORB outlet	
N715	1 1/4 REAR tube inlet	1 1/16-12 REAR ORB outlet	
N716	1 1/2 side tube inlet	1 1/16-12 side ORB outlet	
N720	1 1/4 REAR tube inlet	7/8-14 REAR ORB outlet	



**D Series Model Code**

Code	Inlet	Outlet	Description
<b>B103*</b>	1 5/16-12 side inlet	7/8-14 side outlet,	SAE-A2-Bolt Auxiliary Flange SAEO-ring boss ports No integrated valves
<b>B104*</b>	1 5/16-12 side inlet	1 1/16-12 side outlet	
<b>R104</b>	1 5/16-12 side inlet	1 1/16-12 side outlet	Integrated Relief Valve - Internally Drained Maximum Displacement 23cc

\* Integrated auxiliary flange requires use of input shaft option AH or AC

A variety of integrated valve options including PFD, Steering Covers, and Load sense priority flow dividers covers are available with D Series multiple pumps. Please contact your technical representative to determine which hardware best suits specific application needs.

Code	Inlet	Description
<b>F09A**</b>	15/16-12 side inlet, 3/4-16 side priority, 7/8-14side secondary (SAE A flange)	Integrated Priority Flow Divider, cartridge style relief for settings up to: 221 bar and 34.3 l/min [3200psi and 9 US gal/min]
<b>F09B‡</b>	15/16-12 side inlet, 3/4-16 side priority, 7/8-14side secondary (SAE B flange)	
<b>F13A**</b>	1 5/8-12 rear inlet, 3/4-16 rear priority, 7/8-14 rear secondary (SAE A flange)	
<b>F13B‡</b>	1 5/8-12 rear inlet, 3/4-16 rear priority, 7/8-14 rear secondary (SAE B flange)	
<b>F21A**</b>	15/8-12 side inlet, 3/4-16 side priority, 7/8-14 side secondary (SAE A flange)	
<b>F21B‡</b>	15/8-12 side inlet, 3/4-16 side priority, 7/8-14 side secondary (SAE B flange)	
<b>F25A**</b>	1 5/16-12 rear inlet, 3/4-16 rear priority, 7/8-14 rear secondary (SAE A flange)	
<b>F25B‡</b>	1 5/16-12 rear inlet, 3/4-16 rear priority, 7/8-14 rear secondary (SAE B flange)	
<b>D23A*</b>	15/16-12 side inlet, 3/4-16 side priority, nose secondary port (SAE A flange)	Integrated Steering Cover, Priority Relief Valve (Cartridge Style) for settings up to: 221 bar and 34.3 l/min [3200psi and 9 US gal/min]
<b>D23B**</b>	15/16-12 side inlet, 3/4-16 side priority, nose secondary port (SAE B flange)	
<b>D24A*</b>	1 5/16-12 rear inlet, 3/4-16 rear priority, no secondary port (SAE A flange)	
<b>D24B**</b>	1 5/16-12 rear inlet, 3/4-16 rear priority, no secondary port (SAE B flange)	
<b>L01A**</b>	1 5/16-12 side inlet, 3/4-16 side priority, 7/8-14side secondary, 7/16-20 side LS (SAE-A flange)	Integrated Load Sense Divider (Dynamic), Priority Relief Valve
<b>L01B‡</b>	1 5/16-12 side inlet, 3/4-16 side priority, 7/8-14side secondary, 7/16-20 side LS (SAE-B flange)	
<b>L08A**</b>	1 5/16-12 rear inlet, 3/4-16 rear priority, 7/8-14rear secondary, 7/16-20 rear LS (SAE-A flange)	
<b>L08B‡</b>	1 5/16-12 rear inlet, 3/4-16 rear priority, 7/8-14rear secondary, 7/16-20 rear LS (SAE-B flange)	

\*\* Requires use of mounting flange option AC or AP

‡ Requires use of mounting flange option BC or BP

\* Integrated auxiliary flange requires use of input shaft option AH or AC

**D Series Model Code**
**E Flow control valve**

A	B1	B2	C	L	M	N	P	R	S	D	E	F	H	J	K
D	E	4									•	•	•		

Code	Description	
<b>NNN</b>	No flow control setting, standard for units without integrated flow control valves	
<b>04X</b>	3.8 l/min [1 US gal/min]	For integrated PFD Steering cover with cartridge style relief valve (Cover options F09A, F09B, F13A, F13B, F21A, F21B, F25A or F25B)
<b>08X</b>	7.6 l/min [2 US gal/min]	
<b>11X</b>	11.4 l/min [3 US gal/min]	
<b>15X</b>	15.1 l/min [4 US gal/min]	
<b>19X</b>	18.9 l/min [5 US gal/min]	
<b>23X</b>	22.7 l/min [6 US gal/min]	
<b>27X</b>	26.5 l/min [7 US gal/min]	
<b>30X</b>	30.3 l/min [8 US gal/min]	
<b>34X</b>	34.3 l/min [9 US gal/min]	
<b>38A</b>	10 bar standby	Forintegrated load sense divider (use with L08A or L08B rear ports)
<b>38L</b>	10 bar standby	Forintegrated load sense divider (use with L01A or L01B side ports)
<b>R1N</b>	Maximum flow not to exceed 75 l/min, pressure range from 7-55bar	For integrated relief valve, internally drained (without flow control) Use with R104 cover option 23cc and under
<b>R2N</b>	Maximum flow not to exceed 75 l/min, pressure range from 41-248bar	For integrated relief valve, internally drained (without flow control) Use with R104 cover option 23cc and under

## D Series Model Code

### F Pressure control valve

A	B1	B2	C	L	M	N	P	R	S	D	E	F	H	J	K
D	E	4													

Code	Description
000	No pressure control settings
034	34 bar [500 psi]
041	41 bar [600 psi]
048	48 bar [700 psi]
055	55 bar [800 psi]
062	62 bar [900 psi]
069	69 bar [1000 psi]
076	76 bar [1100 psi]
083	83 bar [1200 psi]
090	90 bar [1300 psi]
097	97 bar [1400 psi]
103	103 bar [1500 psi]
110	110 bar [1600 psi]
117	117 bar [1700 psi]
124	124 bar [1800 psi]
131	131 bar [1900 psi]
138	138 bar [2000 psi]
145	145 bar [2100 psi]
152	152 bar [2200 psi]
159	159 bar [2300 psi]
165	165 bar [2400 psi]
172	172 bar [2500 psi]
179	179 bar [2600 psi]
186	186 bar [2700 psi]
193	193 bar [2800 psi]
200	200 bar [2900 psi]
207	207 bar [3000 psi]
214	214 bar [3100 psi]
221	221 bar [3200 psi]

For integrated priority flow divider (PFD) cover with cartridge style relief valve (Cover options F09A, F09B, F13A, F13B, F21A, F21B, F25A, F25B)  
and  
For integrated steering cover with cartridge style relief valve (Cover options D23A, D23B, D24A, D24B)  
and  
For integrated load sense (LS) cover with cartridge relief valve (Cover options L01A, L01B, L08A, L08B)

### H Assembly screws

A	B1	B2	C	L	M	N	P	R	S	D	E	F	H	J	K
D	E	4													

Code	Description
**	Will be assigned by Turolla upon receipt of order

**D Series Model Code**
**J Nameplate**

A	B1	B2	C	L	M	N	P	R	S	D	E	F	H	J	K	
D	E	4													•	•

Code	Description
AN	Standard nameplate

**K Special feature**

A	B1	B2	C	L	M	N	P	R	S	D	E	F	H	J	K		
D	E	4													•	•	•

Code	Description
NNN	No special features, standard black paint

**D Series Options**

**Shaft options**

A			B1	B2	C	D			E	F	H	J	K		
D	E	1		•	•										

<p><b>Code SE</b>            SAE 9-tooth 16/32-pitch flat root side fit            31.8 mm [1.25 in] length</p> <p>Allowable shaft torque:            118.6 N·m [1050 lbf·in]</p>	<p><b>Code SC and AC</b>            SAE 11-tooth 16/32-pitch flat root side fit            38.1 mm [1.50 in] length</p> <p><b>AC</b>option has 9T auxiliary drive output spline</p> <p>Allowable shaft torque:            176.3 N·m [1560 lbf·in]</p>	<p><b>Code SF</b>            SAE 11-tooth 16/32-pitch flat root side fit            (modified length)            31.8 mm [1.25 in] length</p> <p>Allowable shaft torque:            176.3 N·m [1560 lbf·in]</p>
<p><b>Code SH and AH</b>            SAE 13-tooth 16/32-pitch flat root side fit            41.2 mm [1.62 in] length</p> <p><b>AH</b>option has 9T auxiliary drive output spline</p> <p>Allowable shaft torque:            248.6 N·m [2200 lbf·in]</p>	<p><b>Code SV</b>            SAE 15-tooth 16/32-pitch flat root side fit            46.0 mm [1.81 in] length</p> <p>Allowable shaft torque:            452 N·m [4000 lbf·in]</p>	<p><b>Code PB - 22.2mm</b>            SAE 7/8 in straight keyed, 1/4 in key            41.2 mm [1.62 in] length</p> <p>Allowable shaft torque:            248.6 N·m [2200 lbf·in]</p>
<p><b>Code PD</b>            19mm [3/4 inch] Dia. x 51mm [2.0 inch]            3/16 inch key</p> <p>Allowable shaft torque:            158.2 N·m [1400 lbf·in]</p>	<p><b>Code PZ</b>            25.4mm [1 inch] Dia. x 46mm [1.62 inch]            1/4 inch key</p> <p>Allowable shaft torque:            452 N·m [4000 lbf·in]</p>	<p>Dimensions mm [in]</p>

P108 171E

**D Series Options**

**Code TH**  
 1.8 taper, 22mm [7/8 inch] diameter x 49.3 mm [1.94 in] length, threaded, with nut and washer

Washer  
 Locknut  
 torque  
 50 Nm  
 [37 lbf·ft]

9/16 - 18 x 0.56 thread

Allowable shaft torque:  
 225.9 N·m [2000 lbf·in]

---

**Code TG**  
 1.8 taper, 22mm [7/8 inch] diameter x 50.0 mm [1.95 in] length, threaded, with nut and washer

5/8 - 18 x 0.56 thread

Allowable shaft torque:  
 225.9 N·m [2000 lbf·in]

---

**Code WT**  
 1.8 taper, 22mm [7/8 in] diameter x 49mm [1.94 in] length, threaded, with locknut, washer and 34 tooth helical gear for Perkins engine mount

34 tooth helical gear

Code WT - Only available in 17cc, 19cc, 25cc, 32cc with clockwise [RH] rotation.  
 Use PP mounting flange option.

P106172E

**Multiple pump connecting shaft**

Allowable shaft torque between sections is 144 N·m [1273 lbf·in].

Limit operating pressures when applying multiple section pumps. This ensures the maximum simultaneous input torque through the drive shaft and connecting shafts.

Do not exceed the Allowable Shaft Torque Limits.

**Mounting flanges**

A			B1	B2	C	D	E	F	H	J	K
D	E	1			• •						

## D Series Options

### C Mounting flange

Code	Description
AA	SAE A 2-bolt
AC	SAE A 2-bolt, use with integral PFD/Steering Cover
AM	SAE A 2-bolt, with T seal
AP	SAE A 2-bolt, with T seal, use with integral PFD/Steering cover
AR	SAE A 2-bolt, use with PZ or SV input drive
AS	SAE A 2-bolt, use with integral PFD/Steering cover and PZ or SV input drive
AL	SAE A 2-bolt, two shaft seals with weep hole
AT	SAE A 2-bolt, two shaft seals with weep hole, use with integral PFD/Steering cover

### SAE-A 2-bolt

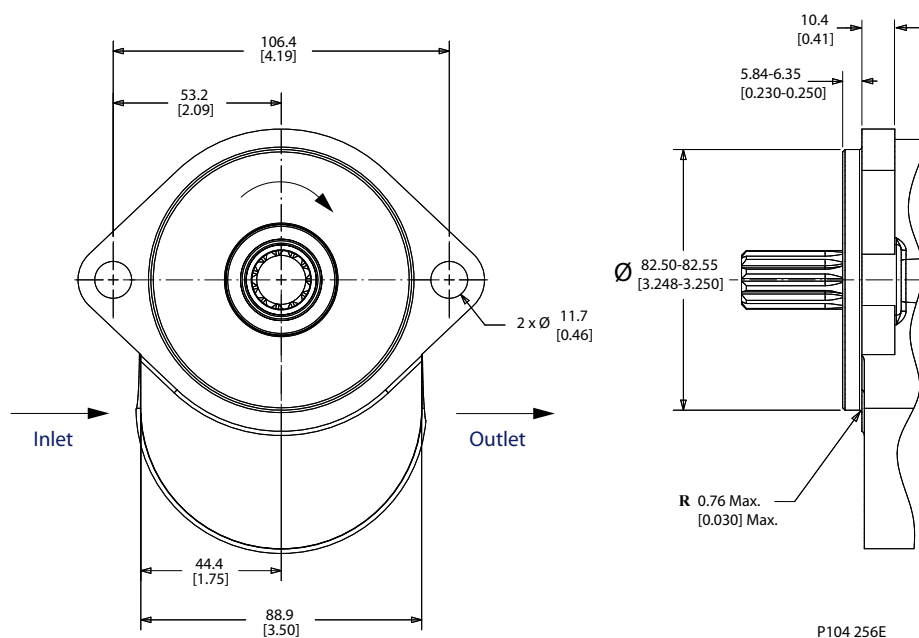

The optional T-Seal is a single piece shaft seal with back-to-back sealing lips. It is most commonly used to prevent mixing of internal/external fluids.

### C Mounting flange

Code	Description
BB	SAE B 2-bolt
BC	SAE B 2-bolt, use with integral PFD/Steering cover
BM	SAE B 2-bolt, with T seal
BP	SAE B 2-bolt, with T seal, use with integral PFD/Steering cover
BR	SAE B 2-bolt, use with PZ or SV input drive
BS	SAE B 2-bolt, use with integral PFD/Steering cover and PZ or SV input drive
BW	SAE B 2-bolt, two shaft seals with weep hole
BT	SAE B 2-bolt, two shaft seals with weep hole, use with integral PFD/Steering cover

**D Series Options**

*SAE B 2-bolt*

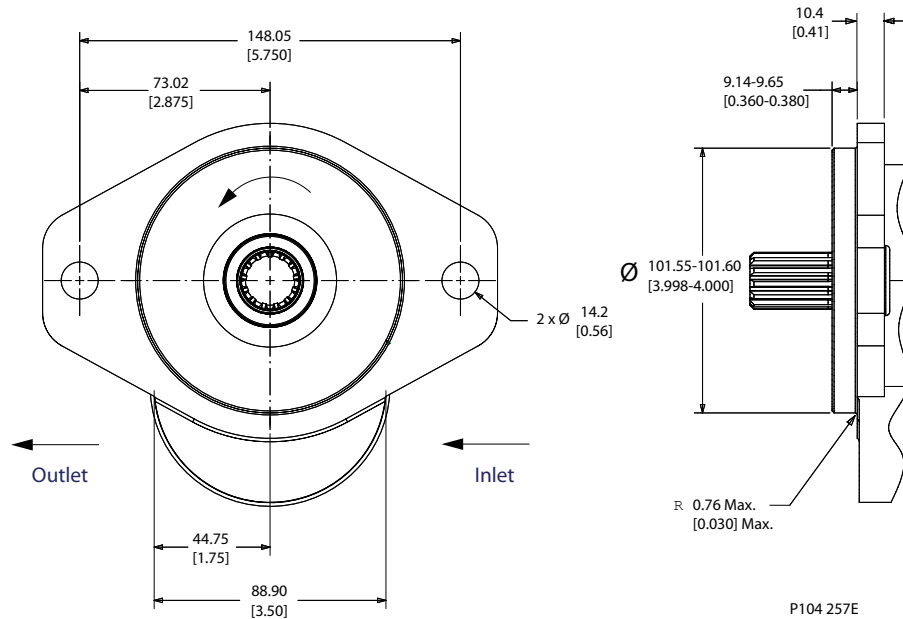

The optional T-Seal is a single piece shaft seal with back-to-back sealing lips. It is most commonly used to prevent mixing of internal/external fluids.

*C Mounting flange*

Code	Description
PP	Perkins 6 bolt flange with (2) seals (use with WT input shaft and clockwise rotation)

*Perkins® 1000 Series Engine Mount, shown with drive gear option WT and clockwise rotation*

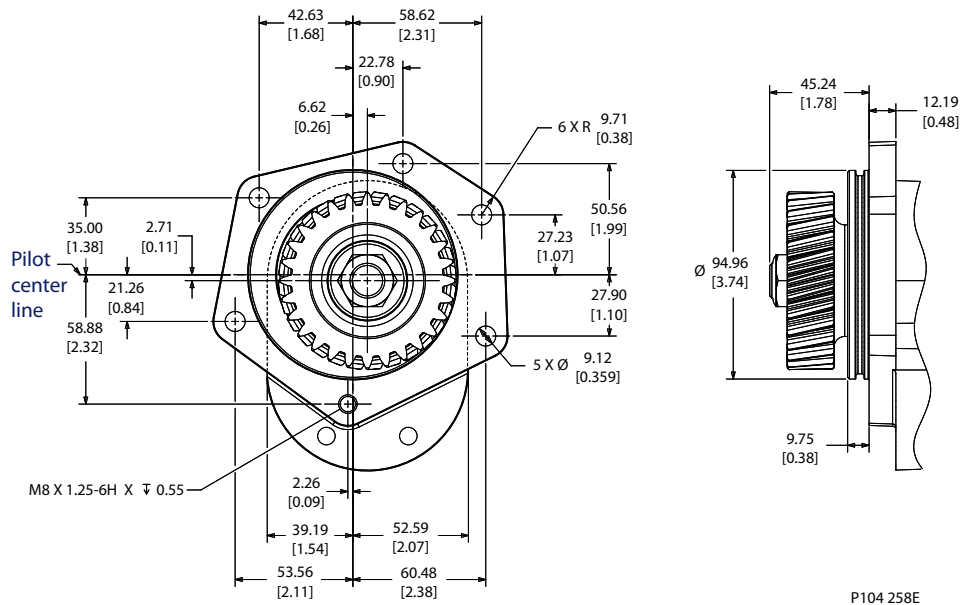

**Multiple pump port options**

The D Series pump is uniquely designed to accommodate multiple pumps with a variety of porting configurations including units with a reduced number of inlets. Reducing the number of inlets can



### D Series Options

eliminate unnecessary hoses and fittings, thereby providing an overall system savings. A typical D series multiple pump does not have isolated sections. Applications requiring sealing between sections should use the SAE auxiliary flange to ensure separation of fluids between sections.

The reference drawings and model code options (R, L, and N) below, describe the first and intermediate port sections of multiple pump configurations. Refer to module D for port options on the final section of a multiple pump.

<b>A</b>	<b>B1</b>	<b>B2</b>	<b>C</b>	<b>R</b>	<b>S</b>	<b>D</b>	<b>E</b>	<b>F</b>	<b>H</b>	<b>J</b>	<b>K</b>
D	E	2		•	•	•					

<b>A</b>	<b>B1</b>	<b>B2</b>	<b>C</b>	<b>L</b>	<b>M</b>	<b>R</b>	<b>S</b>	<b>D</b>	<b>E</b>	<b>F</b>	<b>H</b>	<b>J</b>	<b>K</b>
D	E	3		•	•	•	•	•	•				

<b>A</b>	<b>B1</b>	<b>B2</b>	<b>C</b>	<b>L</b>	<b>M</b>	<b>N</b>	<b>P</b>	<b>R</b>	<b>S</b>	<b>D</b>	<b>E</b>	<b>F</b>	<b>H</b>	<b>J</b>	<b>K</b>
D	E	4		•	•	•	•	•	•						

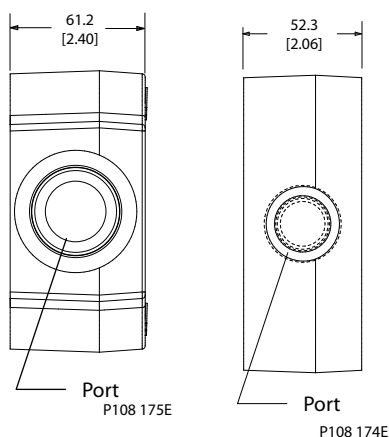

Port code options for modules R, L and N in multiple pump

Code	Inlet port	Outlet port	Maximum recommended inlet flow l/min [US gal/min]
<b>101</b>	1 1/16 - 12, SAE side	7/8 - 14, SAE side	49 [13]
<b>103</b>	1 5/16 - 12, SAE side	7/8 - 14, SAE side	91 [24]
<b>104</b>	1 5/16 - 12, SAE side	1 1/16 - 12, SAE side	91 [24]
<b>113</b>	No inlet	7/8 - 14 SAE, side	N/A
<b>126</b>	No inlet	1 1/16 - 12, side	N/A
<b>704</b>	1 1/4 side tube inlet	7/8 - 14, SAE side ORB	151 [40]
<b>708</b>	1 1/4 side tube inlet	1 1/16 - 12, SAE side ORB	151 [40]

**D Series Options**

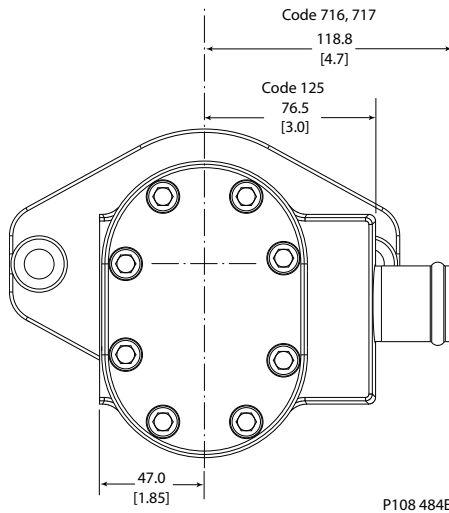

Codes 125, 716 and 717 are commonly used for large displacements and multiple pumps with reduced number of inlets

Code	Inlet port	Outlet port	Maximum recommended inlet flow l/min [US gal/min]
<b>125</b>	1 5/8 - 12, SAE side	1 1/16 - 12, side	151 [40]
<b>716</b>	1 1/2 side tube inlet	1 1/16 - 12, SAE side ORB	204 [54]
<b>717</b>	1 1/2 side tube inlet	7/8 - 14, SAE side ORB	204 [54]

**Rear cover - port options**

**Integrated Valves and Auxiliary Flange**

SAE O-ring boss ports - No integrated valves - No auxiliary flange

Code	Inlet port	Outlet port	Maximum recommended inlet flow l/min [US gal/min]
<b>N101</b>	1 1/16 - 12, SAE side	7/8 - 14, SAE side	49 [13]
<b>N103</b>	1 5/16 - 12, SAE side	7/8 - 14, SAE side	91 [24]
<b>N104</b>	1 5/16 - 12, SAE side	1 1/16 - 12, SAE side	91 [24]
<b>N113</b>	None*	7/8 - 14 SAE, side	- N/A -
<b>N126</b>	None*	1 1/16 - 12, side	- N/A -

\* Used with multiple pump configurations

**D Series Options**

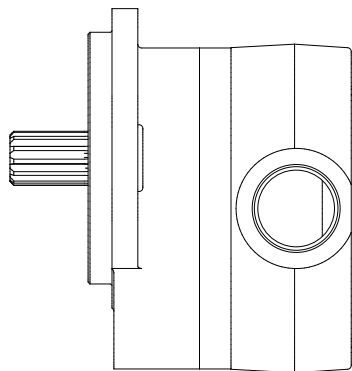

P104 268E

Code	Inlet port	Outlet port	Maximum recommended inlet flow l/min [US gal/min]
<b>N125</b>	1 5/8 - 12, SAE, side	1 1/16 - 12, SAE, side	151 [40]

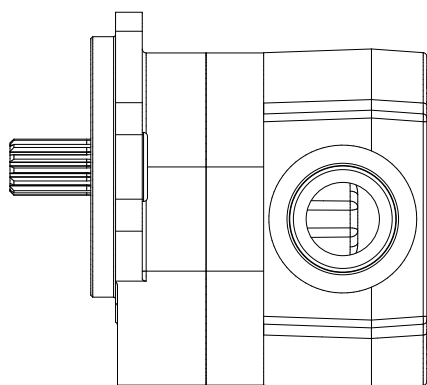

P104 270E

Code	Inlet port	Outlet port	Maximum recommended inlet flow l/min [US gal/min]
<b>N501</b>	1 1/16 - 12, SAE rear	7/8 - 14 SAE, rear	49 [13]
<b>N503</b>	1 5/16 - 12, SAE rear	7/8 - 14, rear	91 [24]
<b>N504</b>	1 5/16 - 12, SAE rear	1 1/16 - 12, SAE rear	91 [24]

**D Series Options**

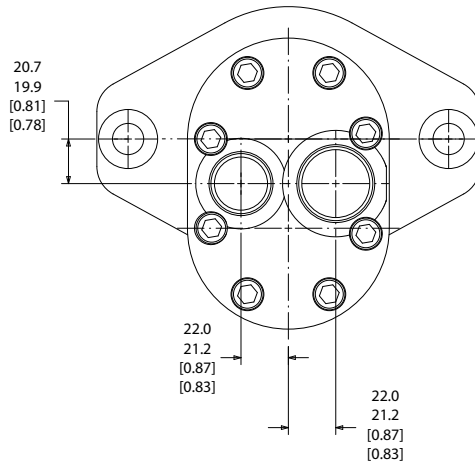

P104 269

*Beaded tube inlet port, SAE O-ring boss ports - No integrated valves - No auxiliary flange*

Code	Inlet port	Outlet port	Maximum recommended inlet flow l/min [US gal/min]
<b>N704</b>	1 1/4 inch side	7/8 - 14 ORB side	151 [40]
<b>N708</b>	1 1/4 inch side	1 1/16-12 ORB side	151 [40]
<b>N715</b>	1 1/4 inch rear	1 1/16-12 ORB rear	151 [40]
<b>N720</b>	1 1/4 inch rear	7/8 - 14 ORB rear	151 [40]

**D Series Options**

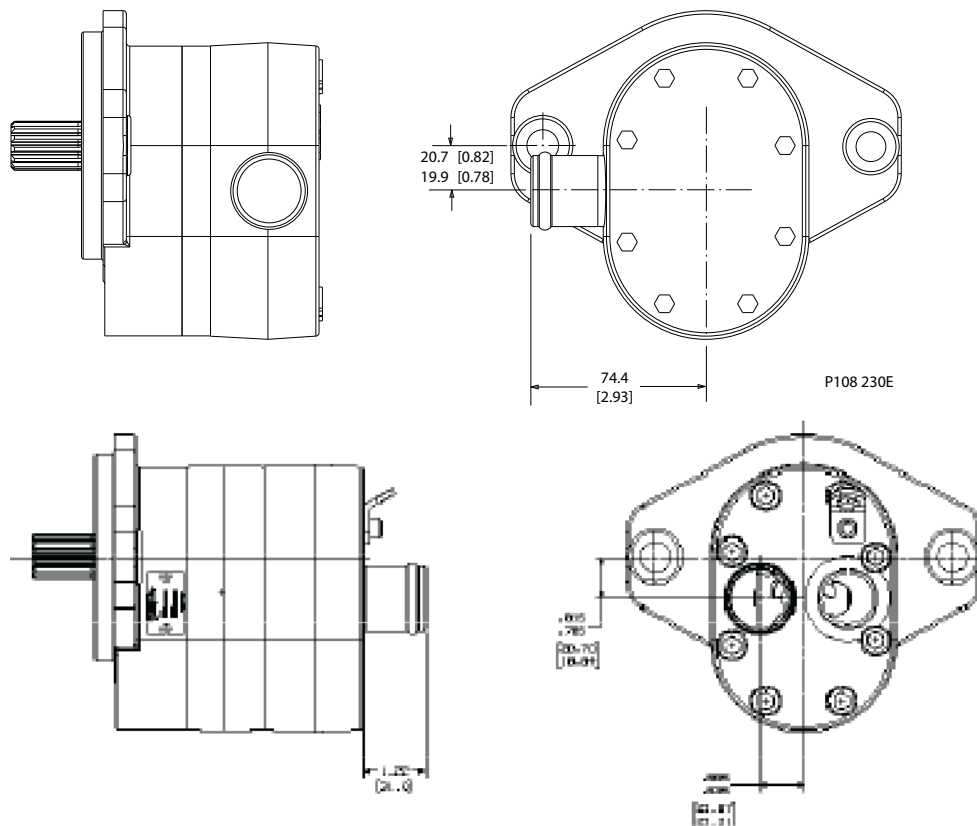

**SAE-A 2-bolt auxiliary flange - SAE O-ring boss ports - No integrated valves**

D Series pumps are available with an optional SAE-A 2-bolt auxiliary flange. Benefits include:

- Flexibility to auxiliary mount any product with SAE-A mounting flange
- Easily combine different product families including D Series with SNP2 aluminum pumps
- Enables sealing between sections to keep fluids isolated for applications where fluids may be drawn from different reservoirs or where sections operate with different fluid types
- Provides capability for customer add-on option

Code	Auxiliary drive	Inlet port	Outlet port	Maximum recommended inlet flow l/min [US gal/min]
<b>B103*</b>	SAE-A 2-bolt, 9T	1 5/16-12 side	7/8 - 14 side	91 [24]
<b>B104*</b>	SAE-A 2-bolt, 9T	1 5/16-12 side	1 1/16-12 side	91 [24]

\* Auxiliary flange requires use of input shaft option AC or AH

**D Series Options**

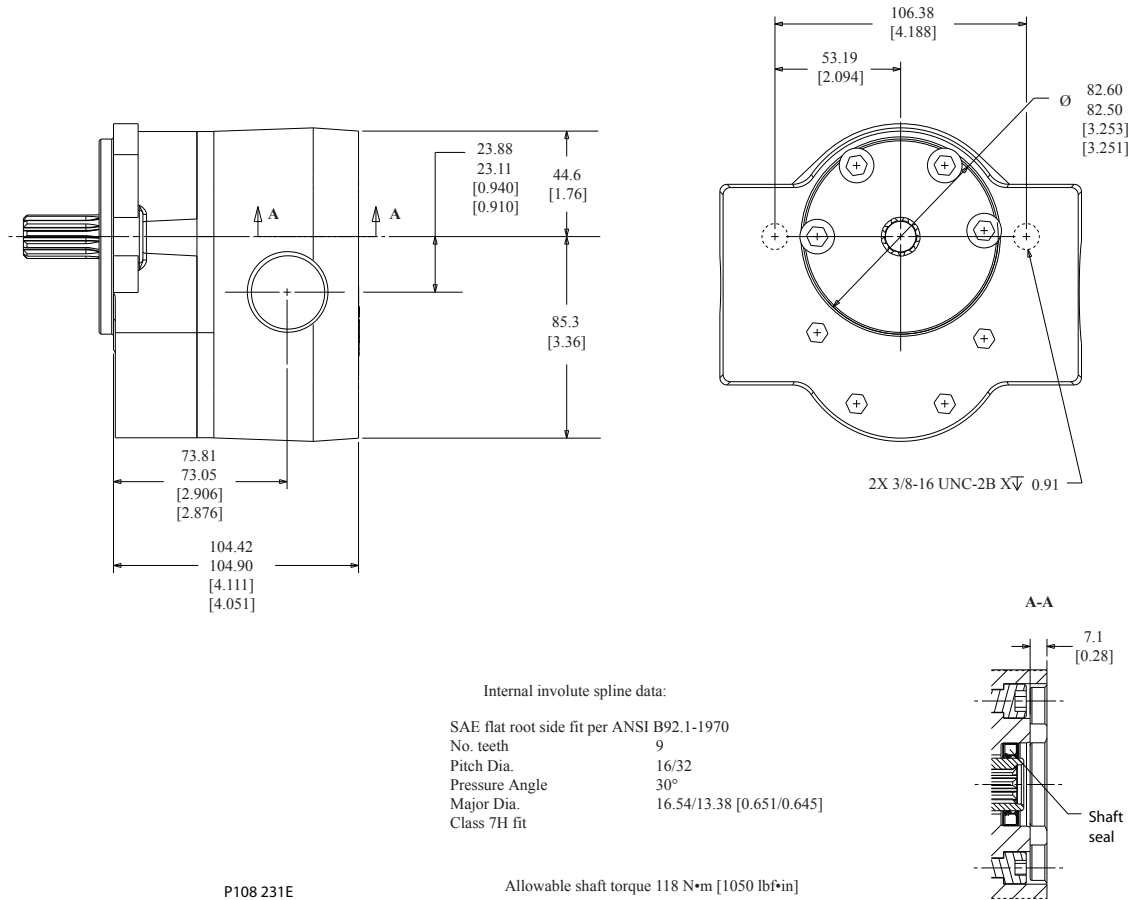

The auxiliary flange option does not ship with a running cover. If the pump will be operated without an auxiliary pump, install a running cover to prevent environmental contamination.

**Integrated Priority Flow Divider**

**Integrated Priority Flow Divider**

D series pumps are available with an optional Priority Flow Divider (PFD) valve integrated into the rear cover. The PFD divides the flow and provides a fixed amount of Controlled Flow (CF) to priority functions such as steering. The remaining flow is routed to the Excess Flow (EF) port for additional functions such as directional control valves and fan drives. The priority flow is pressure compensated and is therefore independent of the excess flow working pressures. The priority flow circuit has an integral, direct acting pilot relief valve with internal drain.

Relief valves are available to suit application pressure and flow requirements. Cartridge style relief - pressures to 221 bar (3200 psi), flows to 34.3 l/min (9 US gal/m)

The D series PFD can be used in tandems and other multiple pump configurations, but only in the rear pumping section. A variety of port sizes and port locations are available. Pumps with PFD covers are rotation specific and require a unique front mounting flange to accommodate the spacing of the assembly bolts.

**D Series Options**

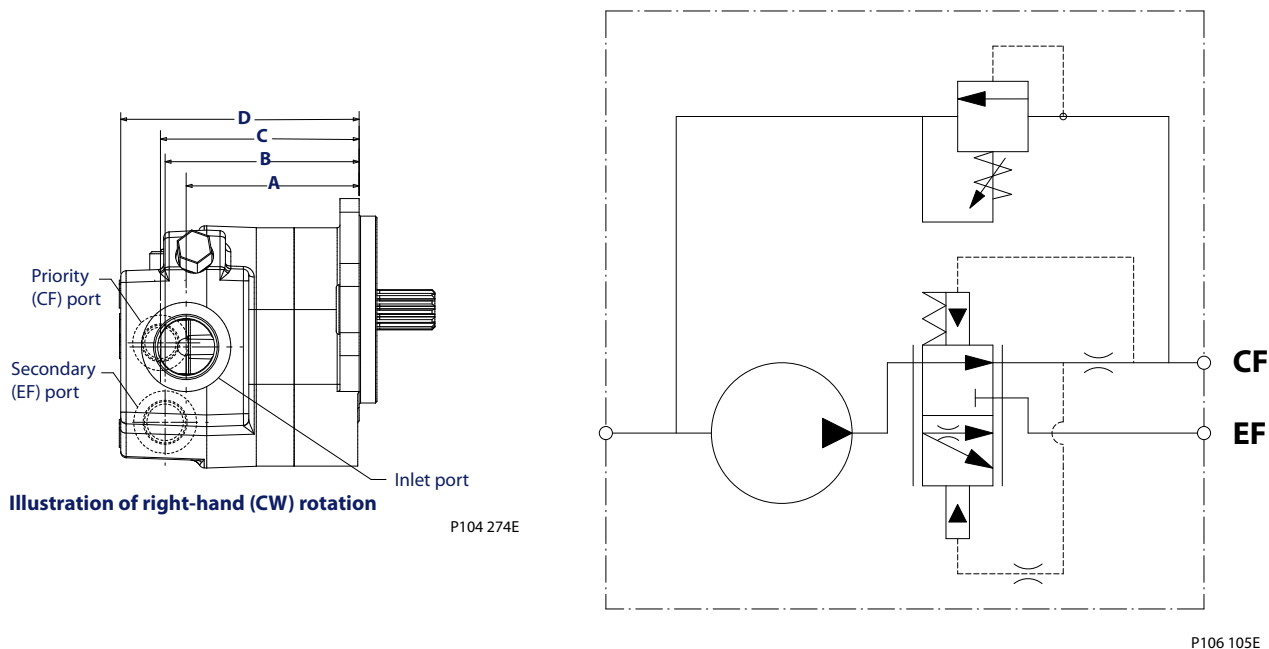

Description	Code	07	10	13	14	17	19	21	23	25	29	32	36	38	41	45
<b>Displacement</b>	cm <sup>3</sup> /rev	7.0	9.5	12.6	14.3	17.0	19.0	20.5	22.5	25.4	29.0	31.8	36.0	38.0	41.0	45.1
	in <sup>3</sup> /rev	0.43	0.58	0.77	0.87	1.04	1.16	1.25	1.37	1.55	1.77	1.94	2.20	2.32	2.50	2.75
<b>Weight</b>	kg	8.8	9.0	9.2	9.3	9.4	9.6	9.6	9.8	9.9	10.1	10.3	10.6	10.7	10.7	11.0
	lb	19.5	19.8	20.2	20.4	20.8	21.1	21.2	21.5	21.9	22.3	22.7	23.3	23.5	23.9	24.4
<b>Dimension A1</b> Inlet port distance up to 1-5/16 SAE	mm	80.5	82.9	86.1	88.3	90.4	92.5	94.0	95.8	98.8	102.4	105.2	109.4	111.4	114.4	118.6
	in	3.17	3.27	3.39	3.48	3.56	3.64	3.70	3.77	3.89	4.03	4.14	4.31	4.39	4.50	4.67
<b>Dimension A2</b> Inlet port distance 1-5/8 SAE	mm	90.2	92.6	95.8	97.9	100.1	102.1	103.6	105.5	108.5	112.0	114.8	119.1	121.1	124.1	128.3
	in	3.55	3.65	3.77	3.86	3.94	4.02	4.08	4.15	4.27	4.41	4.52	4.69	4.77	4.88	5.05
<b>Dimension B</b> Secondary port distance	mm	91.9	94.4	97.5	99.7	101.9	103.9	105.4	107.3	110.2	113.8	116.6	120.9	122.8	125.8	130.0
	in	3.62	3.72	3.84	3.93	4.01	4.09	4.15	4.22	4.34	4.48	4.59	4.76	4.84	4.95	5.12
<b>Dimension C</b> priority port distance	mm	94.5	96.9	100.1	102.2	104.4	106.4	108.0	109.8	112.8	116.4	119.1	123.4	125.4	128.4	132.6
	in	3.72	3.82	3.94	4.03	4.11	4.19	4.25	4.32	4.44	4.58	4.69	4.86	4.94	5.05	5.22
<b>Dimension D</b> overall length	mm	116.1	118.5	121.7	123.8	126.0	128.0	129.5	131.4	134.4	137.9	140.7	145.0	147.0	150.0	154.2
	in	4.57	4.67	4.79	4.88	4.96	5.04	5.10	5.17	5.29	5.43	5.54	5.71	5.79	5.90	6.07

**D Series Options**

**Integrated Priority Flow Divider**

Side Ports (CW rotation), cartridge style

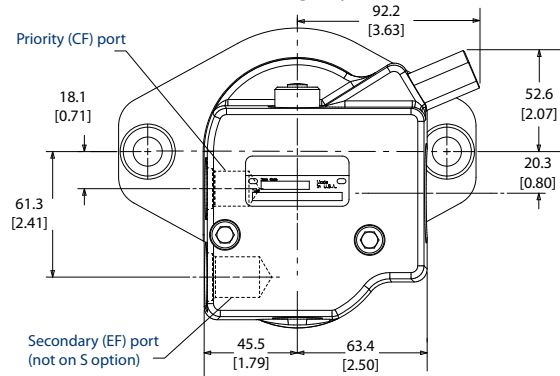

Side Ports (CCW rotation), cartridge style

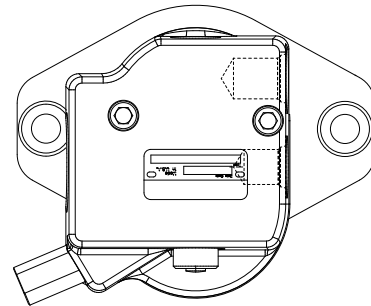

P108 182E

Rear Ports (CW rotation)

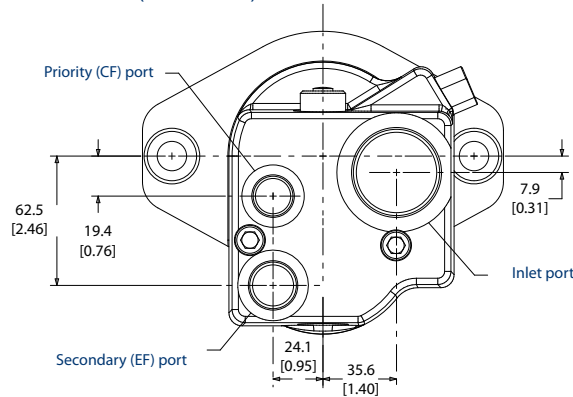

Rear Ports (CCW rotation)

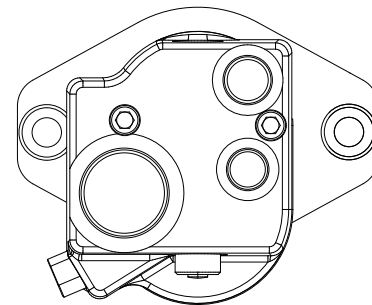

P108 183E

Integrated priority flow dividers require use of mounting flange options AC, AB, AP or BF

**Integrated Priority Flow Divider, cartridge style relief for settings up to 221 bar and 34.3 l/min [3200 psi and 9 US gal/min]**

Code	Description
F09A	1 5/16-12 side inlet, 3/4-16 side priority, 7/8-14 side secondary (SAE A flange)
F09B	1 5/16-12 side inlet, 3/4-16 side priority, 7/8-14 side secondary (SAE B flange)
F13A	1 5/8-12 rear inlet, 3/4-16 rear priority, 7/8-14 rear secondary (SAE A flange)
F13B	1 5/8-12 rear inlet, 3/4-16 rear priority, 7/8-14 rear secondary (SAE B flange)
F21A	1 5/8-12 side inlet, 3/4-16 side priority, 7/8-14 side secondary (SAE A flange)
F21B	1 5/8-12 side inlet, 3/4-16 side priority, 7/8-14 side secondary (SAE B flange)
F25A	1 5/16-12 rear inlet, 3/4-16 rear priority, 7/8-14 rear secondary (SAE A flange)
F25B	1 5/16-12 rear inlet, 3/4-16 rear priority, 7/8-14 rear secondary (SAE B flange)

**Integrated Steering Cover**

D series pumps are available with an optional steering valve integrated into the rear cover.

The steering valve provides a fixed amount of Controlled Flow (CF) for priority functions such as steering. The remaining flow is routed internally to the inlet. The control flow circuit has an integral, direct acting pilot relief valve with internal drain. The relief valve is a cartridge style design suitable for pressures to 221 bar (3200 psi) and flows to 34.3 l/min (9 US gal/m).

The D series steering cover can be used in tandems and other multiple pump configurations, but only in the rear pumping section. A variety of port sizes and port locations are available. Pumps with steering



### D Series Options

covers are rotation specific and require a unique front mounting flange to accommodate the spacing of the assembly bolts.

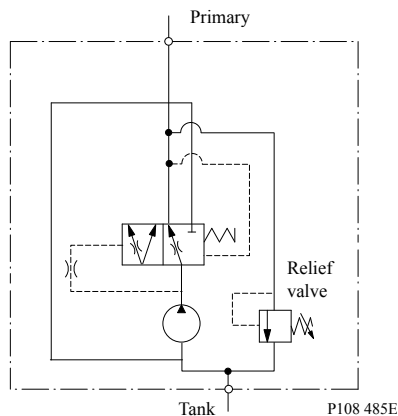

### Integrated Steering Cover

Integrated Steering Cover, cartridge style relief for settings up to [3200 psi and 9 US gal/m*]	
Code	Description
D23A	1 5/16-12 side inlet, 3/4-16 side priority, use with SAE-A mounting flange. No secondary port
D23B	1 5/16-12 side inlet, 3/4-16 side priority, use with SAE-B mounting flange. No secondary port
D24A	1 5/16-12 rear inlet, 3/4-16 rear priority, use with SAE-A mounting flange No secondary port
D24B	1 5/16-12 rear inlet, 3/4-16 rear priority, use with SAE-B mounting flange No secondary port

\* Requires use of mounting flange option AC, BC, AP or BP

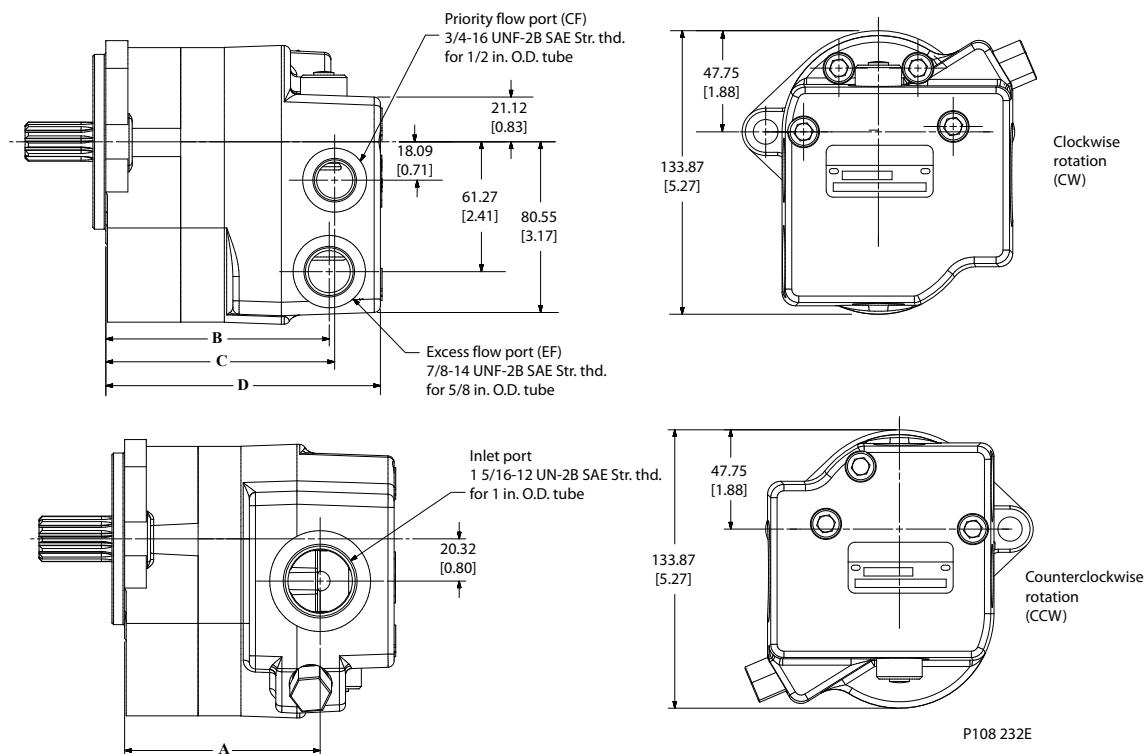

**D Series Options**

Dimension	Displacement cm <sup>3</sup> /rev [in <sup>3</sup> /rev]															
	7.0 [0.43]	9.5 [0.58]	12.6 [.077]	14.3 [0.87]	17.0 [1.04]	19.0 [1.16]	20.5 [1.25]	22.5 [1.37]	25.4 [1.55]	29.0 [1.77]	31.8 [1.94]	36.0 [2.20]	38.0 [2.32]	41.0 [2.50]	45.1 [2.75]	
<b>A</b>	<b>mm</b>	80.5	82.9	86.1	87.8	90.4	92.5	94.0	95.8	98.8	102.4	105.2	109.4	111.4	114.4	118.6
	<b>in</b>	3.17	3.27	3.39	3.46	3.56	3.64	3.70	3.77	3.89	4.03	4.14	4.31	4.39	4.50	4.67
<b>B</b>	<b>mm</b>	92.0	94.4	97.5	99.2	101.9	103.9	105.4	107.3	110.2	113.8	116.6	120.9	122.8	125.8	130.1
	<b>in</b>	3.62	3.72	3.84	3.91	4.01	4.09	4.15	4.22	4.34	4.48	4.59	4.76	4.84	4.95	5.12
<b>C</b>	<b>mm</b>	94.5	96.9	100.1	101.7	104.4	106.4	108.0	109.8	112.8	116.4	119.1	123.4	125.4	128.4	132.6
	<b>in</b>	3.72	3.82	3.94	4.01	4.11	4.19	4.25	4.32	4.44	4.58	4.69	4.86	4.94	5.05	5.22
<b>D</b>	<b>mm</b>	116.1	118.5	121.7	123.3	126.0	128.0	129.6	131.4	134.4	138.0	140.7	145.0	147.0	150.0	154.2
	<b>in</b>	4.57	4.67	4.79	4.86	4.96	5.04	5.10	5.17	5.29	5.43	5.54	5.71	5.79	5.90	6.07

**Load Sense Priority Flow Valve**

D series pumps are available with an optional Load Sense (LS) priority valve integrated into the rear cover.

The LS priority valve supplies priority flow on demand to functions such as load sense steering, while the Excess Flow (EF) is available for secondary functions such as directional control valves and fan drives.

A load sense signal line from the priority circuit to the gear pump's LS port governs flow to the primary circuit. As the load sense signal pressure increases, priority (CF) flow also increases. When the controlled function is idle (no load sense demand), full pump flow is available for the secondary functions.

- The D series LS priority valve is available with 40 l/min [10 US gal/min] and 80 l/min [21 US gal/min] flow settings.
- The priority circuit is available with an optional integral direct acting pilot relief valve with internal drain. Pressure settings range from 34 to 172 bar [500 to 2500 psi].
- The load sense valve is dynamic and has a constant flow of 0.5 to 1.0 l/min [0.13 to 0.26 US gal/min] present at all times to ensure fast reaction.
- The D series PFD can be used in tandems and other multiple pump configurations, but only in the rear pumping section.
- Rear and side porting options are available.

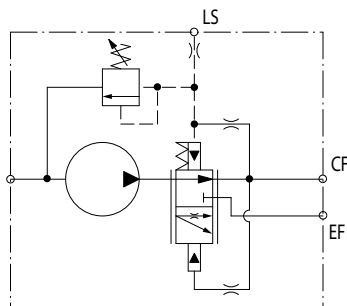

P104 279

[Contact your Danfoss representative for information concerning load sense port options.](#)

**D Series Options**

**Pumps with Load Sense Priority Flow Valves**

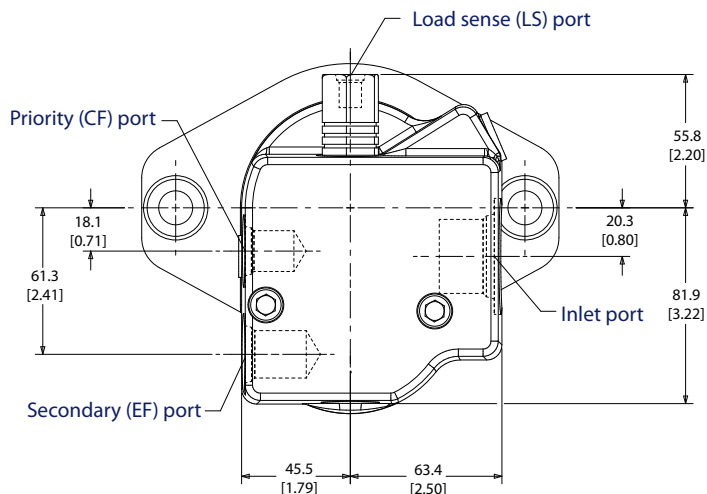

P104 280E

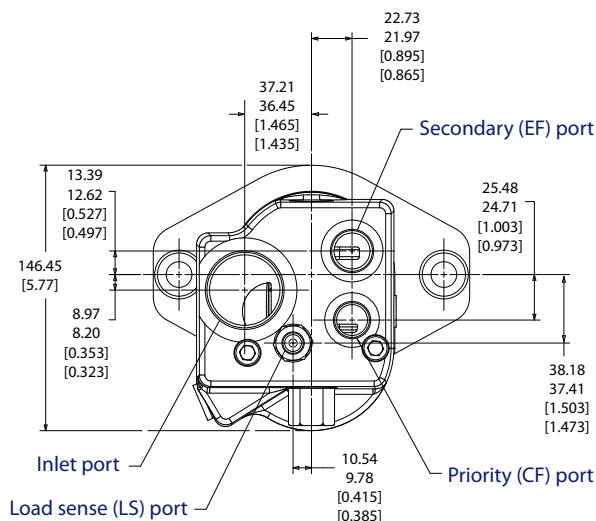
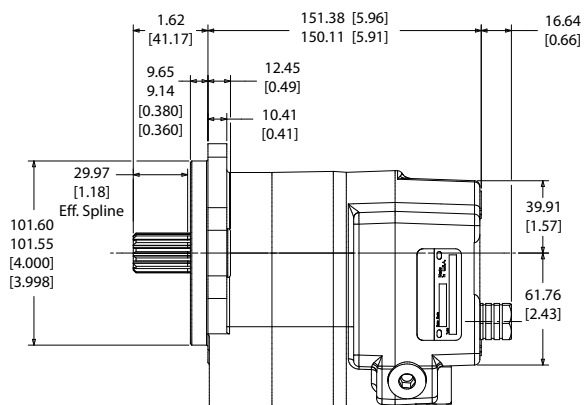

P104 281E

Description	Code	07	10	11	13	14	17	19	21	23	25	29	32	36	38	41	45
Displacement	cm <sup>3</sup> /rev	7.0	9.5	10.8	12.6	14.3	17.0	19.0	20.5	22.5	25.4	29.0	31.8	36.0	38.0	41.0	45.1
	in <sup>3</sup> /rev	0.43	0.58	0.66	0.77	0.87	1.04	1.16	1.25	1.37	1.55	1.77	1.94	2.20	2.32	2.50	2.75
Weight	kg	8.8	9.0	9.1	9.2	9.3	9.4	9.6	9.6	9.8	9.9	10.1	10.3	10.6	10.7	10.7	11.0
	lb	19.5	19.8	20.0	20.2	20.4	20.8	21.1	21.2	21.5	21.9	22.3	22.7	23.3	23.5	23.9	24.4
Dimension A1 Inlet port distance sizes up to 1-5/16 in SAE	mm	80.5	82.9	84.5	86.1	88.3	90.4	92.5	94.0	95.8	98.8	102.4	105.2	109.4	111.4	114.4	118.6
	in	3.17	3.27	3.31	3.39	3.48	3.56	3.64	3.70	3.77	3.89	4.03	4.14	4.31	4.39	4.50	4.67
Dimension A2 Inlet port distance 1-5/8 in SAE	mm	90.2	92.6	94.0	95.8	97.9	100.1	102.1	103.6	105.5	108.5	112.0	114.8	119.1	121.1	124.1	128.3
	in	3.55	3.65	3.69	3.77	3.86	3.94	4.02	4.08	4.15	4.27	4.41	4.52	4.69	4.77	4.88	5.05
Dimension B Secondary port distance	mm	91.9	94.4	95.8	97.5	99.7	101.9	103.9	105.4	107.3	110.2	113.8	116.6	120.9	122.8	125.8	130.0
	in	3.62	3.72	3.78	3.84	3.93	4.01	4.09	4.15	4.22	4.34	4.48	4.59	4.76	4.84	4.95	5.12
Dimension C priority port distance	mm	94.5	96.9	98.5	100.1	102.2	104.4	106.4	108.0	109.8	112.8	116.4	119.1	123.4	125.4	128.4	132.6
	in	3.72	3.82	3.88	3.94	4.03	4.11	4.19	4.25	4.32	4.44	4.58	4.69	4.86	4.94	5.05	5.22

**D Series Options**

Description	Code	07	10	11	13	14	17	19	21	23	25	29	32	36	38	41	45
<b>Dimension D overall length</b>	mm	116.1	118.5	120.0	121.7	123.8	126.0	128.0	129.5	131.4	134.4	137.9	140.7	145.0	147.0	150.0	154.2
	in	4.57	4.67	4.71	4.79	4.88	4.96	5.04	5.10	5.17	5.29	5.43	5.54	5.71	5.79	5.90	6.07

## D Series Dimension Drawings

### One Section - Single

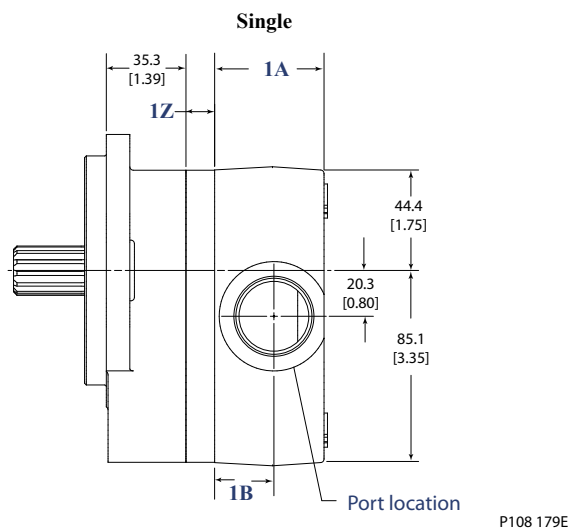

Dimension	Section 1	
	1A	1B
Standard Ports: N101, N103, N113, N126, N501, N503, N504	45 [1.91]	24 [0.96]
Oversized Ports N125, N704, N708	63.5 [2.5]	31.75 [1.25]

Displacement	Units	07	10	11	13	14	17	19	21	23	25	29	32	36	38	41	45
Dimension Z	mm	7.1	9.7	10.9	12.7	14.4	17.0	19.1	20.6	22.5	25.4	29.0	31.8	36.1	38.1	41.0	45.2
	in	0.28	0.38	0.43	0.50	0.57	0.67	0.75	0.81	0.88	1.00	1.14	1.25	1.42	1.50	1.61	1.78

#### How to determine overall length

The overall length of the single section pump (as measured from the mounting flange) can be calculated by adding the dimension of the mounting flange to the combined length of the pumping section. The length of the pumping section is dependent upon the displacement (dimension Z) and the selection of ports (standard or oversized).

$$\text{Overall length of single section pump} = 35.3 [1.39] + 1Z + 1A$$

#### How to determine the position of inlet/outlet ports

Generally speaking, the inlet and outlet ports are centrally located within each port section. Therefore, the position of the inlet/outlet port (as measured from the mounting flange) can be calculated as follows:

$$\text{Location of port 1} = 35.3 [1.39] + 1Z + 1B$$

**D Series Dimension Drawings**

**Two section - Tandem**

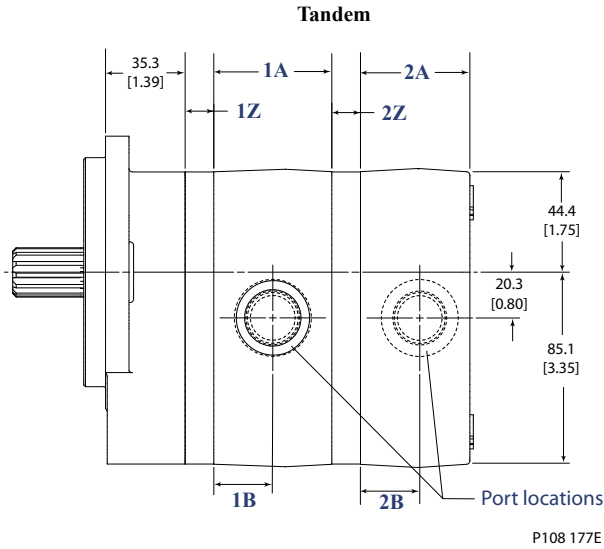

Dimension				
Standard Ports: 101, 103, 104, 113, 126, 704, 708 N101, N103, N113, N126, N501, N503, N504	52.3 [2.06]	26.15 [1.03]	48.5 [1.91]	24.25 [1.03]
Oversized Ports: 125, 716, 717, N125, N704, N708	61.2 [2.4]	30.6 [1.2]	63.5 [2.5]	31.75 [1.25]

**How to determine overall length**

The overall length of the two section pump (as measured from the mounting flange) can be calculated by adding the dimension of the mounting flange to the combined length of each section. The length of the section is dependent upon the displacement (dimension Z) and the selection of ports (standard or oversized).

$$\text{Overall length of two section pump} = 35.3 [1.39] + 1Z + 1A + 2Z + 2A$$

**How to determine the position of inlet/outlet ports**

Generally speaking, the inlet and outlet ports are centrally located within each port section. Therefore, the position of each port (as measured from the mounting flange) can be calculated as follows:

$$\text{Location of port 1} = 35.3 [1.39] + 1Z + 1B$$

$$\text{Location of port 2} = 35.3 [1.39] + 1Z + 1A + 2Z + 2B$$

## D Series Dimension Drawings

### Three Section - Triple

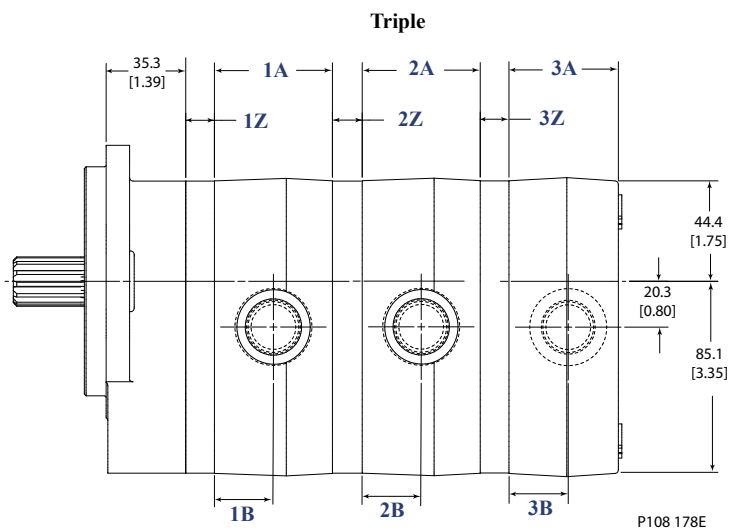

Dimension	Section 1 and 2		Section 3	
	1A	1B	2A	2B
Standard Ports: 101, 103, 104, 113, 126, 704, 708 N101, N103, N113, N126, N501, N503, N504	52.3 [2.06]	26.15 [1.03]	48.5 [1.91]	24.25 [1.03]
Oversized Ports: 125, 716, 717, N125, N704, N708	61.2 [2.4]	30.6 [1.2]	63.5 [2.5]	31.75 [1.25]

Displacement	Units	07	10	11	13	14	17	19	21	23	25	29	32	36	38	41	45
Dimension Z	mm	7.1	9.7	10.9	12.7	14.4	17.0	19.1	20.6	22.5	25.4	29.0	31.8	36.1	38.1	41.0	45.2
	in	0.28	0.38	0.43	0.50	0.57	0.67	0.75	0.81	0.88	1.00	1.14	1.25	1.42	1.50	1.61	1.78

#### How to determine overall length

The overall length of the three section pump (as measured from the mounting flange) can be calculated by adding the dimension of the mounting flange to the combined length of each pumping section. The length of each pumping section is dependent upon the displacement (dimension Z) and the selection of ports (standard or oversized).

$$\text{Overall length of three section pump} = 35.3 [1.39] + 1Z + 1A + 2Z + 2A + 3Z + 3A$$

#### How to determine the position of inlet/outlet ports

Generally speaking, the inlet and outlet ports are centrally located within each port section. Therefore, the position of each port (as measured from the mounting flange) can be calculated as follows:

$$\text{Location of port 1} = 35.3 [1.39] + 1Z + 1B$$

$$\text{Location of port 2} = 35.3 [1.39] + 1Z + 1A + 2Z + 2B$$

$$\text{Location of port 3} = 35.3 [1.39] + 1Z + 1A + 2Z + 2A + 3Z + 3B$$

**D Series Dimension Drawings**

**Four Section - Quad**

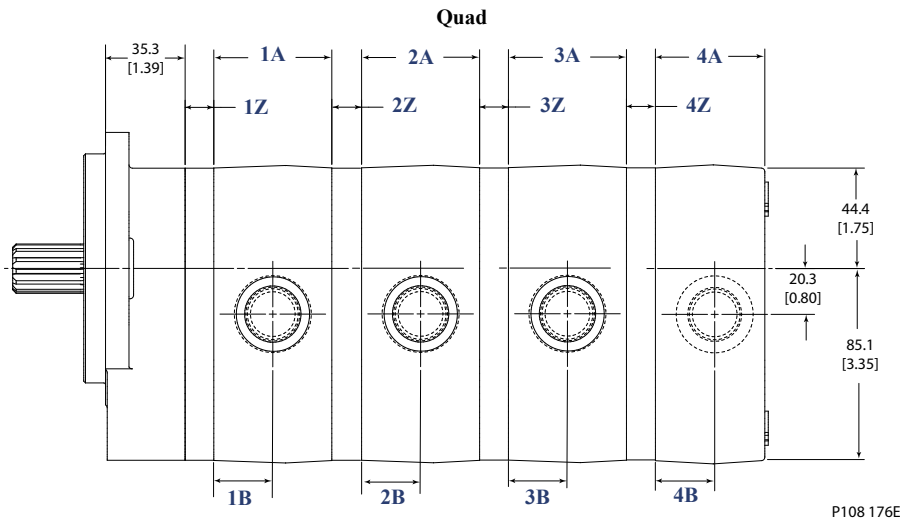

Dimension	Section 1, 2, 3		Section 4	
	1A	1B	2A	2B
Standard Ports: 101, 103, 104, 113, 126, 704, 708 N101, N103, N113, N126, N501, N503, N504	52.3 [2.06]	26.15 [1.03]	48.5 [1.91]	24.25 [1.03]
Oversized Ports: 125, 716, 717, N125, N704, N708	61.2 [2.4]	30.6 [1.2]	63.5 [2.5]	31.75 [1.25]

Displacement	Units	07	10	11	13	14	17	19	21	23	25	29	32	36	38	41	45
Dimension Z	mm	7.1	9.7	10.9	12.7	14.4	17.0	19.1	20.6	22.5	25.4	29.0	31.8	36.1	38.1	41.0	45.2
	in	0.28	0.38	0.43	0.50	0.57	0.67	0.75	0.81	0.88	1.00	1.14	1.25	1.42	1.50	1.61	1.78

**How to determine overall length**

The overall length of the four section pump (as measured from the mounting flange) can be calculated by adding the dimension of the mounting flange to the combined length of each pumping section. The length of each pumping section is dependent upon the displacement (dimension Z) and the selection of ports (standard or oversized).

$$\text{Overall length of four section pump} = 35.3 [1.39] + 1Z + 1A + 2Z + 2A + 3Z + 3A + 4Z + 4A$$

**How to determine the position of inlet/outlet ports**

Generally speaking, the inlet and outlet ports are centrally located within each port section. Therefore, the position of each port (as measured from the mounting flange) can be calculated as follows:

$$\text{Location of port 1} = 35.3 [1.39] + 1Z + 1B$$

$$\text{Location of port 2} = 35.3 [1.39] + 1Z + 1A + 2Z + 2B$$

$$\text{Location of port 3} = 35.3 [1.39] + 1Z + 1A + 2Z + 2A + 3Z + 3B$$

$$\text{Location of port 4} = 35.3 [1.39] + 1Z + 1A + 2Z + 2A + 3Z + 3A + 4Z + 4B$$



## D Series Performance Data

### Flow performance

The graphs on this, and the following pages, show output flow for the D series single pumps at various working pressures as a function of speed. Data were taken using hydraulic fluid conforming to ISO VG46 at 50°C (120° F) with viscosity at 28 mm<sup>2</sup>/sec (cSt) [132 SUS].

Model 07D ... l/min (left); US gal/min (right)

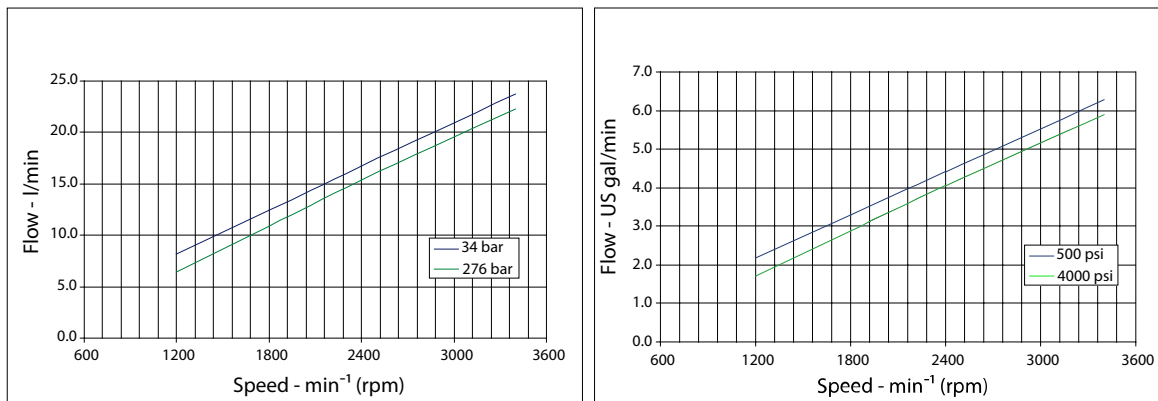

Model 10D ... l/min (left); US gal/min (right)

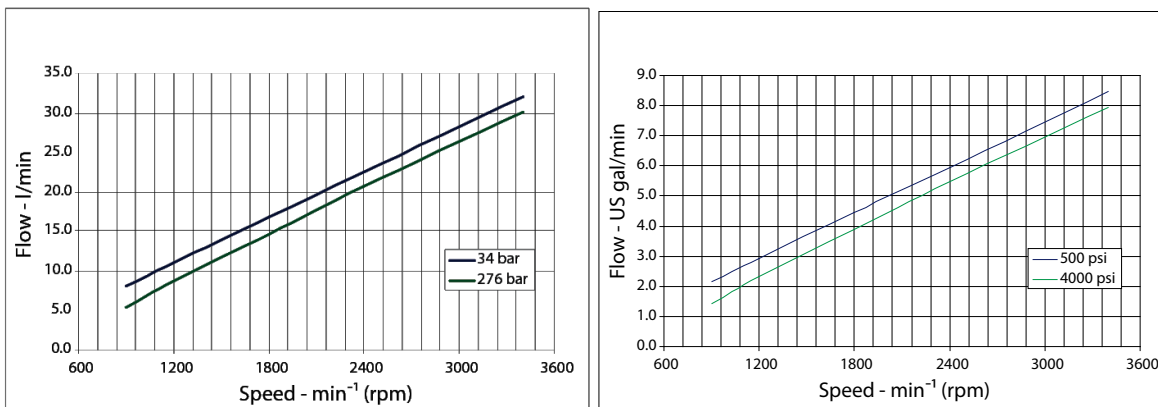

Model 13D ... l/min (left); US gal/min (right)

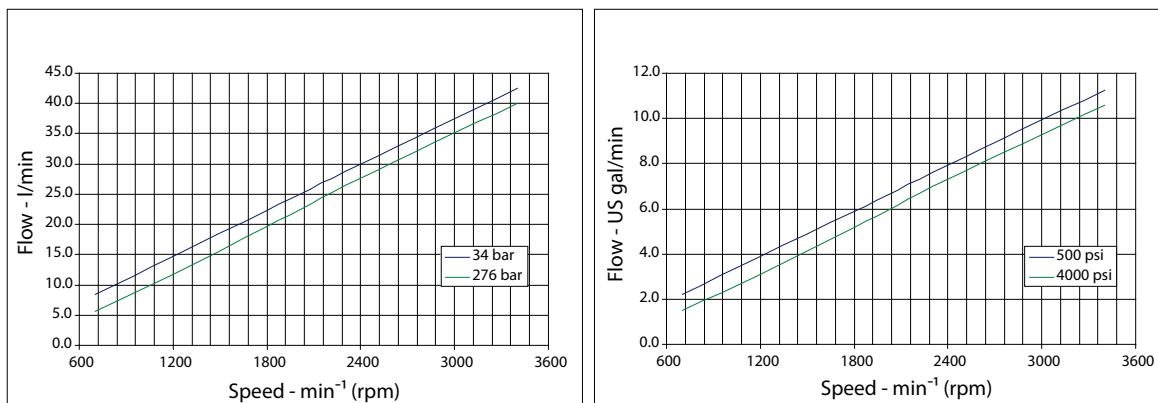

**D Series Performance Data**

*Model 14D ... l/min (left); US gal/min (right)*

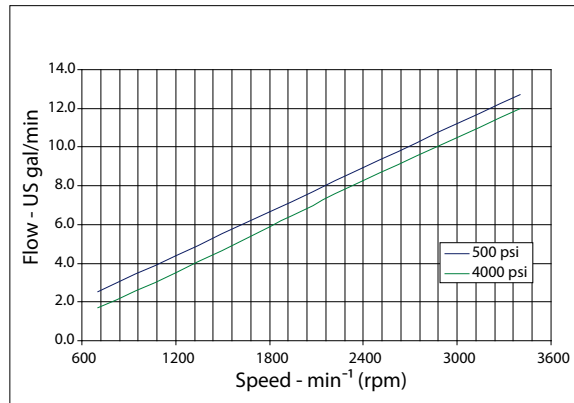
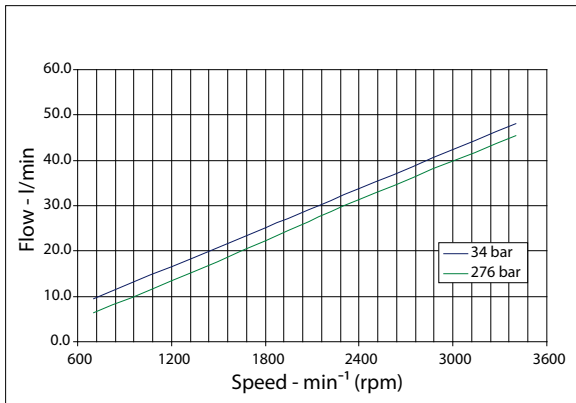

*Model 17D ... l/min (left); US gal/min (right)*

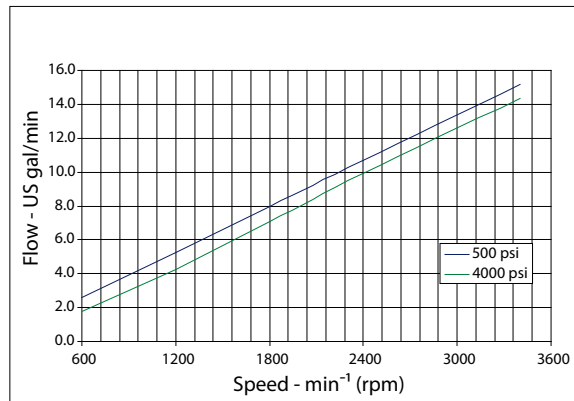
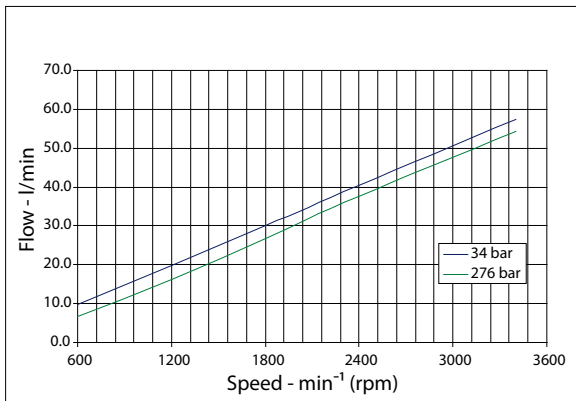

*Model 19D ... l/min (left); US gal/min (right)*

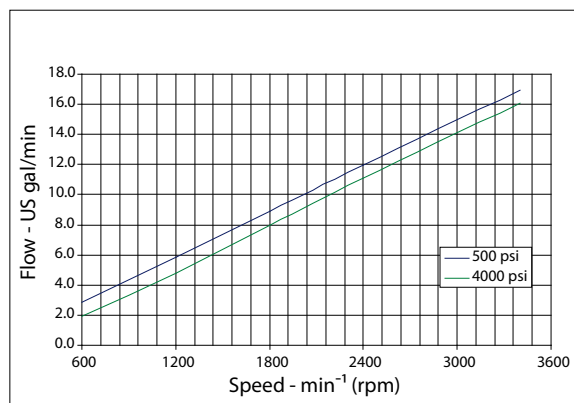
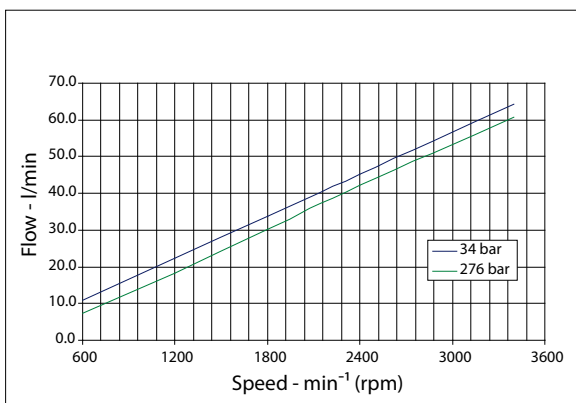

**D Series Performance Data**

Model 21D ... l/min (left); US gal/min (right)

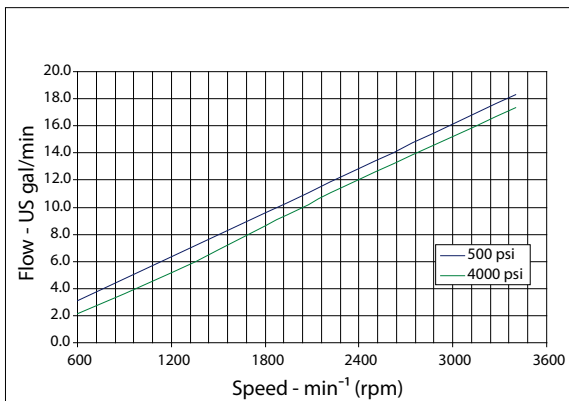
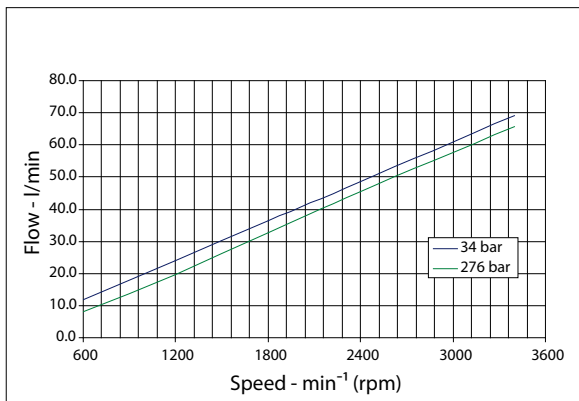

Model 23D ... l/min (left); US gal/min (right)

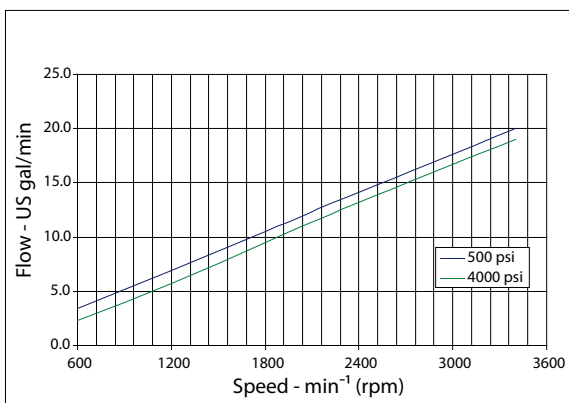
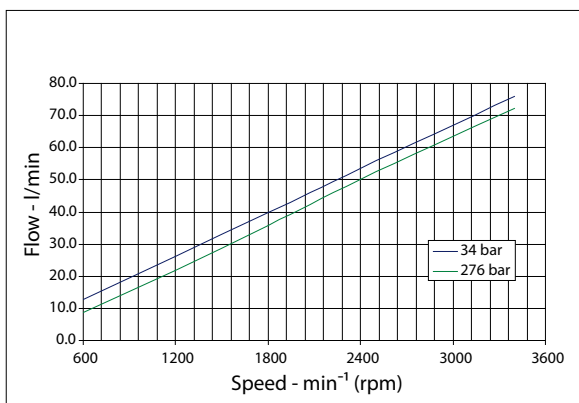

Model 25D ... l/min (left); US gal/min (right)

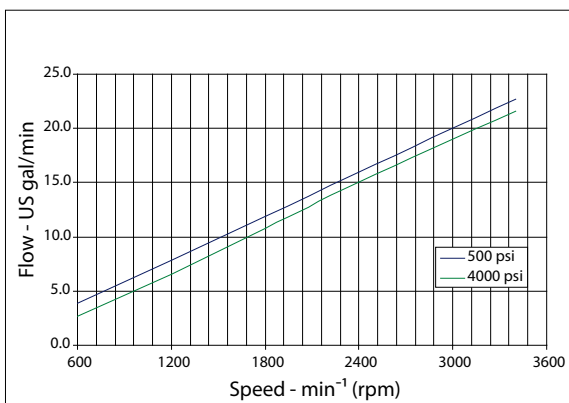
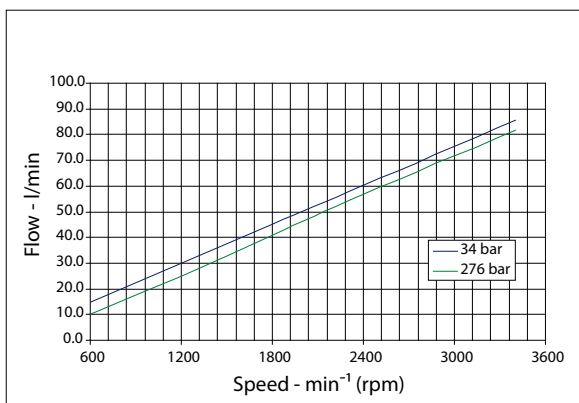

**D Series Performance Data**

Model 29D ... l/min (left); US gal/min (right)

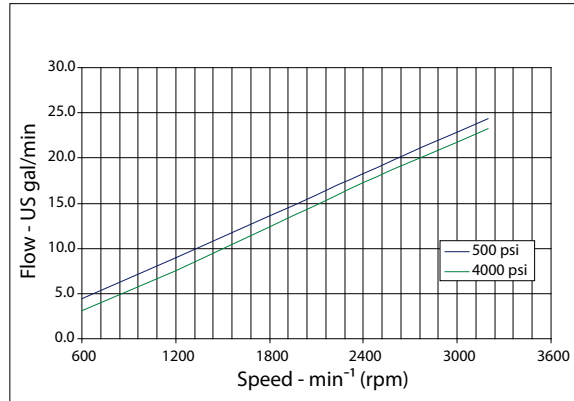
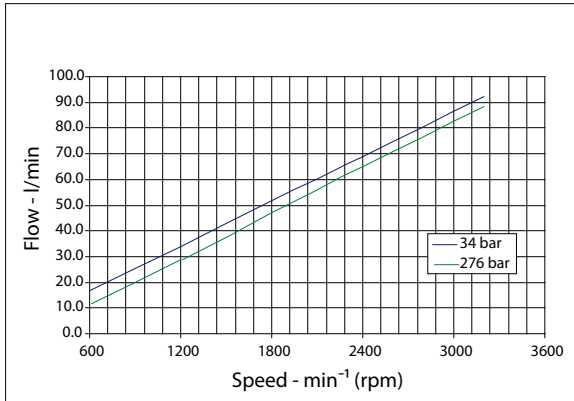

Model 32D ... l/min (left); US gal/min (right)

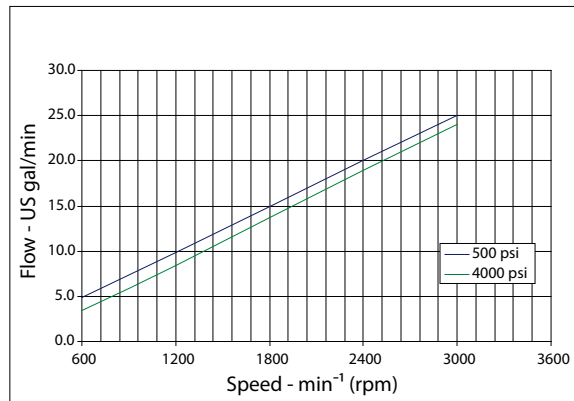
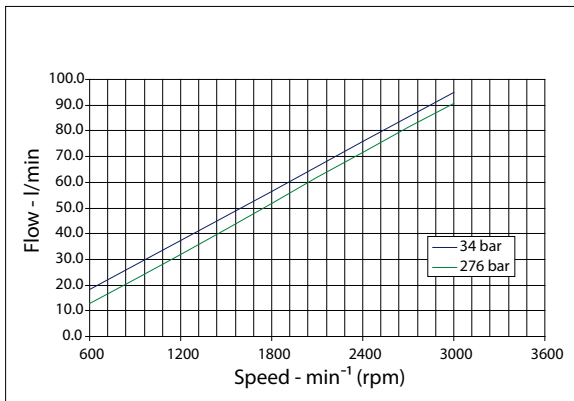

Model 38D ... l/min (left); US gal/min (right)

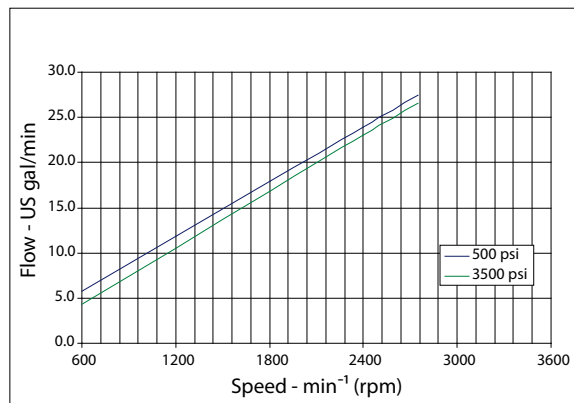
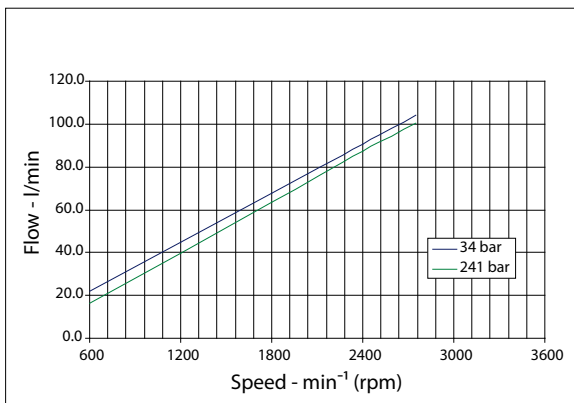

**D Series Performance Data**

Model 41D ... l/min (left); US gal/min (right)

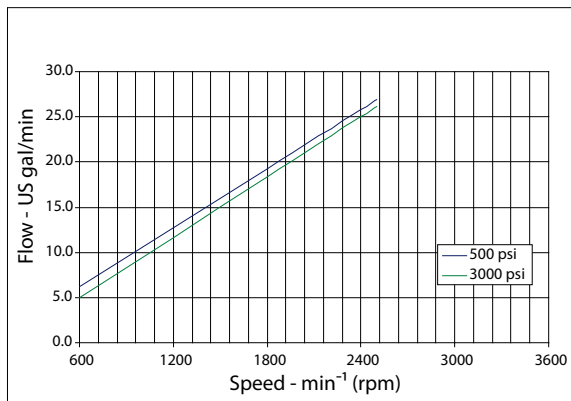
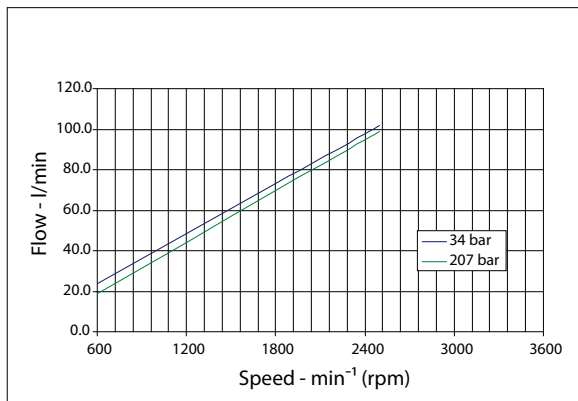

Model 45D ... l/min (left); US gal/min (right)

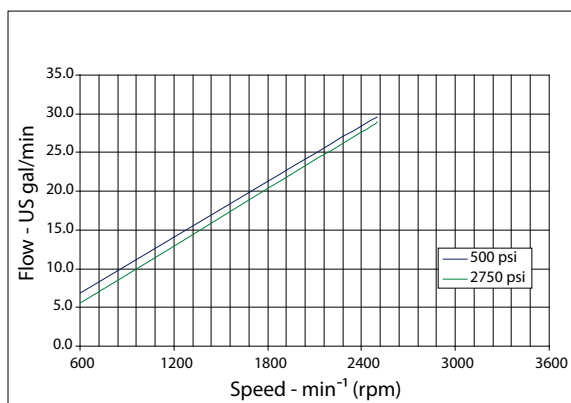
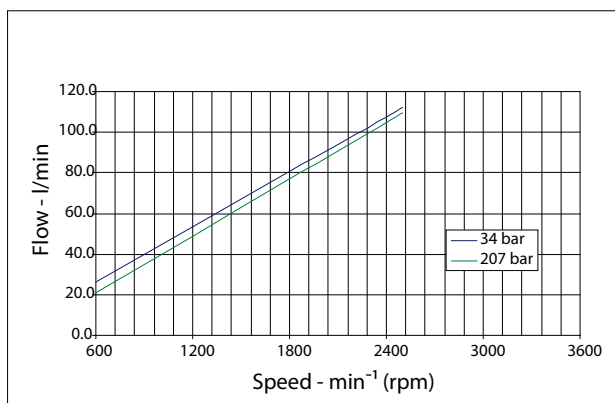

### XD Model Code Information

#### A Rotation - viewed from drive shaft

A				B1	B2	C	R	S	D	E	F	H	J	K	
D	E	2	•												

Code	Description
DE2	DE2- XD Series, Cast Iron Gear Pump
L	Left hand (CCW) Rotation
R	Right hand (CW) Rotation

#### B1 Displacement - front section

A				B1	B2	C	R	S	D	E	F	H	J	K	
D	E	2		•	•										

For the B module, the first two numbers specify the displacement

Code	Description
17	17cc [1.04 CIR]
19	19cc [1.16 CIR]
21	21cc [1.25 CIR]
23	23cc [1.37 CIR]
25	25cc [1.55 CIR]
29	29cc [1.77 CIR]
32	32cc [1.94 CIR]
36	36cc [2.20 CIR]
38	38cc [2.32 CIR]
41	41cc [2.50 CIR]
45	45cc [2.75 CIR]

#### B2 Input shaft

A				B1	B2	C	R	S	D	E	F	H	J	K	
D	E	2	•												

For the B module, the second two letters specify the shaft code

Code	Description
SH*	SAE 13 tooth spline, 41 mm [1.62 in] length
SV	15tooth spline, 46 mm [1.81 in] length (use with mounting flange AR or BR)
PB*	22 mm [7/8 in] diameter, 41 mm [1.62 in] length, with 1/4 key
PZ	25.4 mm [1 in] diameter, 46 mm [1.81 in] length with 1/4 key

\* SH and PB shafts are torque limited. Displacements above 51cc require reduced operating pressures when using these shafts

## XD Model Code Information

### C Mounting flange

A			B1	B2	C	R	S	D			E	F	H	J	K	
D	E	2			• •											

Code	Description
AA	SAE A 2-bolt
AR	SAEA 2-bolt, use with 15 T spline input drive
BB	SAE B 2-bolt
BR	SAEB 2-bolt, use with 15 T spline input drive

### R Ports - first section

A			B1	B2	C	R	S	D			E	F	H	J	K	
D	E	2				• • •										

Code	Description
150*	1 5/8-12 SAE ORB side inlet, 1 5/16-12 SAE ORB side outlet
154*	1 5/8-12 SAE ORB side inlet, 1 1/16-12 SAE ORB side outlet
346	1 1/4 side split flange inlet, 1 1/4 side split flange outlet (SAE Code 61)
736	1 1/2 inch side beaded tube inlet, 1 1/4 side split flange outlet (SAE Code 61)
750	1 1/2 inch side beaded tube inlet, 1 5/16-12 SAE ORB side outlet
946	1 1/4 Split flange inlet (SAE Code 61), 1 5/16-12 SAE ORB side outlet

\* N150 and N154 ports are flow limited. Displacements above 45cc require reduced operating speed when using this port option.

### S Displacement - rear section

A			B1	B2	C	R	S	D			E	F	H	J	K	
D	E	2					• •									

Code	Description
X5	17cc [1.04 CIR]
X6	19cc [1.16 CIR]
X7	21cc [1.25 CIR]
X8	23cc [1.37 CIR]
X9	25cc [1.55 CIR]
XC	29cc [1.77 CIR]
XD	32cc [1.94 CIR]
XF	36cc [2.20 CIR]
XG	38cc [2.32 CIR]
XH	41cc [2.50 CIR]
XK	45cc [2.75 CIR]

### D Rear cover

A			B1	B2	C	R	S	D			E	F	H	J	K	
D	E	2						• • • •								

### XD Model Code Information

Code	Description
N100	No Inlet, No Outlet

### E Flow control valve

A			B1	B2	C	R	S	D	E	F	H	J	K
D	E	2							•	•	•		

Code	Description
NNN	No flow control setting

### F Pressure control valve

A			B1	B2	C	R	S	D	E	F	H	J	K
D	E	2								•	•	•	

Code	Description
000	No pressure control settings

### H Assembly screws

A			B1	B2	C	R	S	D	E	F	H	J	K
D	E	2									•	•	

<b>Screws</b>	<b>Front pump port code, Module: R = 150, 154, 346, 736, 750, 946</b> <b>Rear pump port code, Module: D = N100</b>												
	<b>Combined Displacement</b>												
	34	38	41	45	51	58	64	72	76	82	90		
<b>Screw Code</b>	AW	AX	AX	AX	AY	AZ	BA	BC	BC	BE	BE		

### J Name plate

A			B1	B2	C	R	S	D	E	F	H	J	K
D	E	2										•	•

Code	Description
AN	Standard nameplate

### K Special features

A			B1	B2	C	R	S	D	E	F	H	J	K
D	E	2											•

Code	Description
NNN	No special features, standard black paint



### XD Options

### XD Shaft options

A			B1	B2	C	R	S	D	E	F	H	J	K
D	E	2		•	•								

<p><b>Code SH</b>            SAE 13-tooth 16/32-pitch flat root side fit            41.2 mm [1.62 in] length</p> <p>Allowable shaft torque:            248.6 N·m [2200 lbf·in]</p>	<p><b>Code SV</b>            SAE 15-tooth 16/32-pitch flat root side fit            46.0 mm [1.81 in] length</p> <p>Allowable shaft torque:            452 N·m [4000 lbf·in]</p>
<p><b>Code PB - 22.2mm</b>            SAE 7/8 in straight keyed, 1/4 in key            41.2 mm [1.62 in] length</p> <p>Allowable shaft torque:            248.6 N·m [2200 lbf·in]</p>	<p><b>Code PZ</b>            25.4mm [1 inch] Dia. x 46mm [1.62 inch]            1/4 inch key</p> <p>Allowable shaft torque:            452 N·m [4000 lbf·in]</p>

### XD Mounting flanges

A			B1	B2	C	R	S	D	E	F	H	J	K
D	E	2			•	•							

Code	Description
AA	SAE A 2-bolt
AR	SAE A 2-bolt, use with PZ or SV input drive

**XD Options**

SAE A 2-bolt

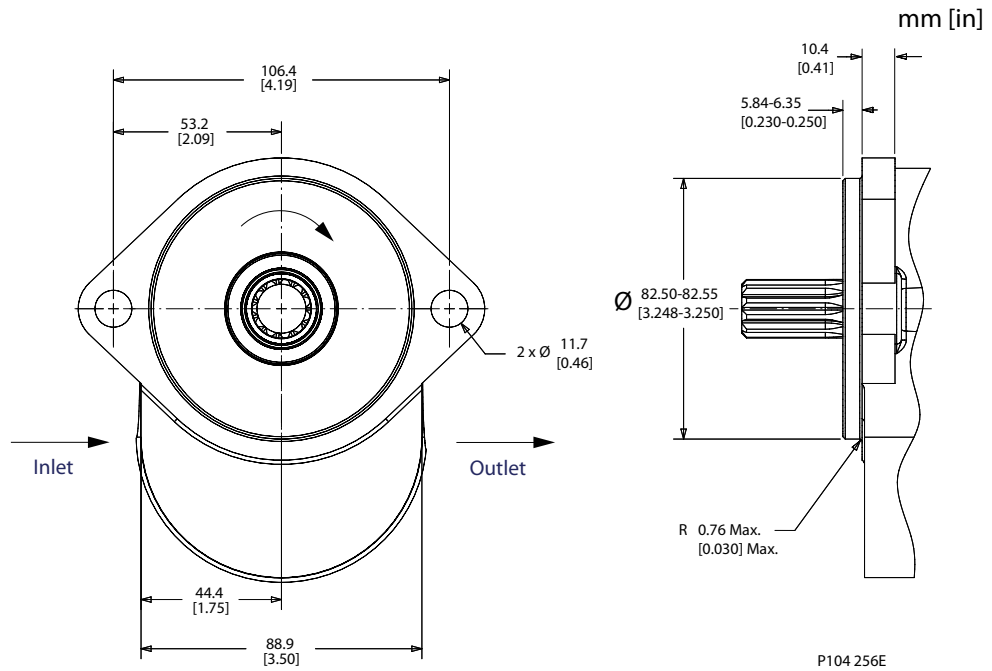

A	B1	B2	C	R	S	D	E	F	H	J	K
D	E	2	•	•							

Code	Description
BB	SAE B 2-bolt
BR	SAE B 2-bolt, use with PZ or SV input drive

**XD Options**

SAE B 2-bolt

mm [in]

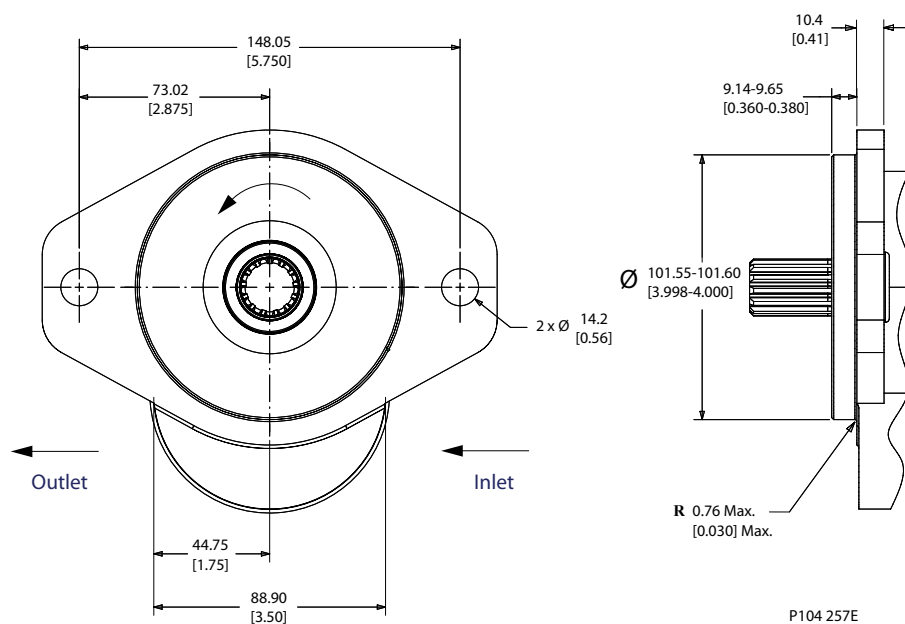

### XD Dimension Drawings Information

#### Dimensions

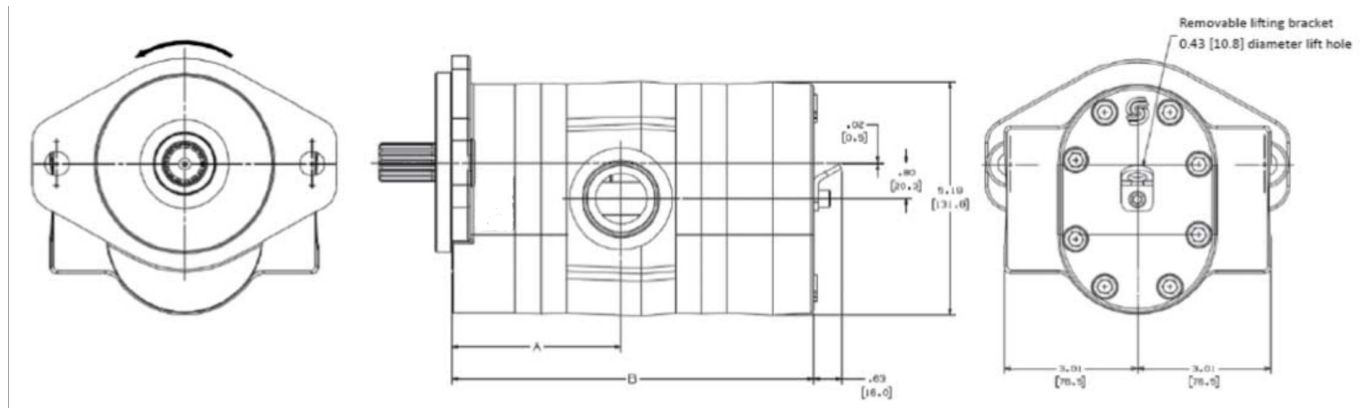

#### Reference Combination

Ratings	Units	34	38	41	45	51	58	64	72	76	82	90
Displacement	cm <sup>3</sup> /rev	34.0	38.0	41.0	45.0	50.8	58.0	63.6	72.2	76.0	82.0	90.2
	in <sup>3</sup> /rev	2.08	2.32	2.50	2.74	3.10	3.54	3.88	4.40	4.64	5.00	5.50
Rated pressure	bar	276	276	276	276	276	276	255	226	215	200	180
	psi	4000	4000	4000	4000	4000	4000	3700	3275	3100	2880	2620
Peak pressure	bar	303	303	303	303	303	303	285	250	235	220	200
	psi	4400	4400	4400	4400	4400	4400	4130	3625	3400	3200	2900
Maximum speed	maximum	3400	3400	3400	3400	3400	3200	3000	2750	2700	2500	2275
Theoretical flow at max speed	l/min	116	129	139	153	173	186	191	199	205	205	205
	US gal/min	31	34	37	40	46	49	50	52	54	54	54
Dimension A	mm	82.9	85.0	86.5	88.3	91.3	94.9	97.7	102	104	106.8	111.1
	in	3.27	3.35	3.41	3.48	3.6	3.74	3.85	4.02	4.1	4.21	4.38
Dimension B	mm	179.1	183.1	186.2	189.7	195.8	202.9	208.5	217.2	221.2	226.8	235.5
	in	7.05	7.21	7.33	7.47	7.71	7.99	8.21	8.55	8.71	8.93	9.27

[Review application speeds and pressures for specific displacement, shaft, and port combinations.](#)

#### Products we offer:

- DCV directional control valves
- Electric converters
- Electric machines
- Electric motors
- Gear motors
- Gear pumps
- Hydrostatic motors
- Hydrostatic pumps
- Orbital motors
- PLUS+1® controllers
- PLUS+1® displays
- PLUS+1® joysticks and pedals
- PLUS+1® operator interfaces
- PLUS+1® sensors
- PLUS+1® software
- PLUS+1® software services, support and training
- Position controls and sensors
- PVG proportional valves
- Steering components and systems
- Telematics

**Danfoss Power Solutions** is a global manufacturer and supplier of high-quality hydraulic and electric components. We specialize in providing state-of-the-art technology and solutions that excel in the harsh operating conditions of the mobile off-highway market as well as the marine sector. Building on our extensive applications expertise, we work closely with you to ensure exceptional performance for a broad range of applications. We help you and other customers around the world speed up system development, reduce costs and bring vehicles and vessels to market faster.

Danfoss Power Solutions – your strongest partner in mobile hydraulics and mobile electrification.

#### Go to [www.danfoss.com](http://www.danfoss.com) for further product information.

We offer you expert worldwide support for ensuring the best possible solutions for outstanding performance. And with an extensive network of Global Service Partners, we also provide you with comprehensive global service for all of our components.

#### Hydro-Gear

[www.hydro-gear.com](http://www.hydro-gear.com)

#### Daikin-Sauer-Danfoss

[www.daikin-sauer-danfoss.com](http://www.daikin-sauer-danfoss.com)

Local address:

**Danfoss  
Power Solutions (US) Company**  
2800 East 13th Street  
Ames, IA 50010, USA  
Phone: +1 515 239 6000

**Danfoss  
Power Solutions GmbH & Co. OHG**  
Krokamp 35  
D-24539 Neumünster, Germany  
Phone: +49 4321 871 0

**Danfoss  
Power Solutions ApS**  
Nordborgvej 81  
DK-6430 Nordborg, Denmark  
Phone: +45 7488 2222

**Danfoss  
Power Solutions Trading  
(Shanghai) Co., Ltd.**  
Building #22, No. 1000 Jin Hai Rd  
Jin Qiao, Pudong New District  
Shanghai, China 201206  
Phone: +86 21 2080 6201

Danfoss can accept no responsibility for possible errors in catalogues, brochures and other printed material. Danfoss reserves the right to alter its products without notice. This also applies to products already on order provided that such alterations can be made without subsequent changes being necessary in specifications already agreed. All trademarks in this material are property of the respective companies. Danfoss and the Danfoss logotype are trademarks of Danfoss A/S. All rights reserved.