

PLUS+1™ IOX012-010 Expansion Module

Mobile Machine Management

The IOX012-010 input/output (I/O) expansion module is an element of the flexible, powerful and expandable PLUS+1 family of mobile machine management products. Expansion modules provide cost-effective additional I/O to mobile machine control systems.

Product Highlights

Expansion modules are associated with a PLUS+1 controller. PLUS+1 GUIDE (Graphical User Integrated Development Environment) applications running in the controller read inputs from and write outputs to expansion module pins as if the pins are physically located on the controller. Pin properties are configured in the controller's GUIDE application.

PLUS+1 compliance eliminates need for the system designer to write CAN transmit and receive messages in both the controller and associated expansion modules.

Application Development

Users configure expansion modules using PLUS+1 GUIDE. This Microsoft® Windows®-based development environment features a user-friendly, field proven, icon-based graphical programming tool, application downloader, and service/diagnostic tool.

Local Address:



IOX012-010 Expansion Module

Features

- 12 pin Deutsch® DTM connector
- 4 inputs
 - (3) universal (DIN/AIN/FreqIN) that are user-defined as either:
 - Analog:* with configurable ranges 0 to 5.25 Vdc (with over range protection) or 0 to 36 Vdc;
 - Digital:* pull up (5 Vdc) or pull down (0 Vdc);
 - Frequency (timing):* 1 Hz to 10 kHz
 - (1) fixed range analog (AIN/CAN shield) 0 to 5.25 Vdc or CAN shield pin
- 2 outputs
 - (2) universal (PWMOUT/DOOUT/PVGOUT) that are user-defined as either:
 - Digital:* (3 A), configurable as a source or sink;
 - PWM:* (30 to 4000 Hz) configurable as open or closed loop with current control;
 - Analog voltage:* open loop PWM at 4000 Hz.
 - Any PWMOUT/DOOUT/PVGOUT can be used to provide reference power to one PVG valve.
- 9 to 36 Vdc power supply, monitored internally
- 1 CAN 2.0B port, the fixed range analog input can be configured as the shield pin
- Power supply for external sensors rated at 5 Vdc to 100 mA and regulated internally
- 3 mounting alternatives: stack, end , or side
- CE compliant

IOX012-010 Dimensions and Pin Assignments

mm [in]

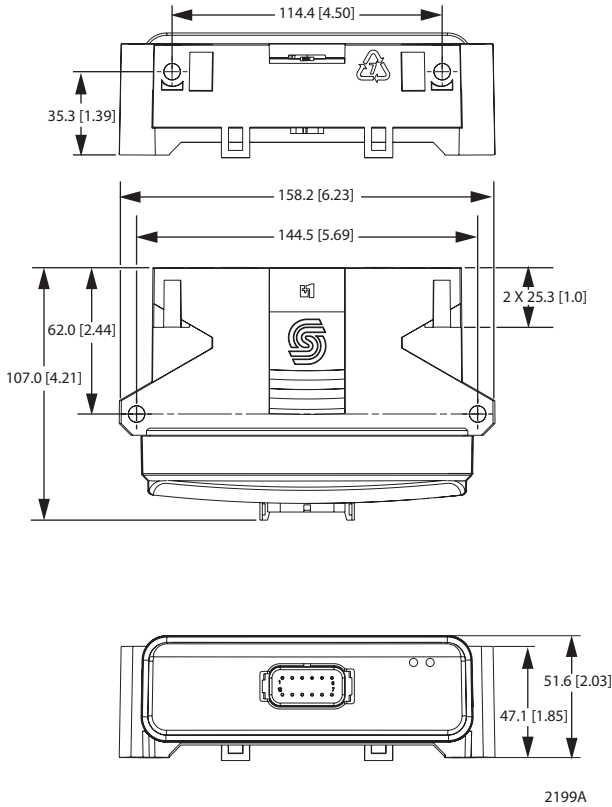

12 Pin Connector

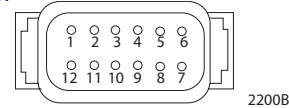

Pin	Controller function
C1-P1	Power ground -
C1-P2	Power supply +
C1-P3	CAN +
C1-P4	CAN -
C1-P5	AIN/CAN shield
C1-P6	5 Vdc sensor power +
C1-P7	Sensor power ground -
C1-P8	DIN/AIN/FreqIN
C1-P9	DIN/AIN/FreqIN
C1-P10	DIN/AIN/FreqIN
C1-P11	PWMOUT/DOU/PVGOUT
C1-P12	PWMOUT/DOU/PVGOUT

Use care when wiring mating connector.
Above pinouts are for device pins.

⚠ Caution

This device is not field serviceable. Opening the device housing will void the warranty.

Specifications

Product Parameters

Supply voltage	9 to 36 Vdc
Operating temperature (ambient)	-40°C to 70°C [-40°F to 158°F]
Storage temperature	-40°C to 85°C [-40°F to 185°F]
Programming temperature	0°C to 70°C [32°F to 158°F]
IP rating (with mating connector attached)	IP 67
EMI/ RFI rating	100 V/m
Weight	0.34 kg [0.75 lb]
Vibration	IEC 60068-2-64
Shock	IEC 60068-2-27 test Ea
Maximum current, sourcing	8 A
Maximum current, sinking	8 A

Ordering Information

IOX012-010	10100997
-------------------	----------

Related product	Sauer-Danfoss material number	
CG150 CAN/USB Gateway	10104136	
Deutsch® mating connector bag assembly	10102025 (16 to 20 AWG)	10100944 (20 to 24 AWG)
PLUS+1 GUIDE single user license	10101000	

Comprehensive technical information: *PLUS+1 Controller Family Technical Information, 520L0719*;
PLUS+1 Compliant IOX012-010 Function Block User Manual, 11063394
Sauer-Danfoss product literature on line at: www.sauer-danfoss.com