

VERSATILE AND PRECISE.

MINIATURE METAL BELLOWS COUPLINGS

SERIES MK | 0.05 – 10 Nm



R+W[®]
COUPLING TECHNOLOGY

THE ULTIMATE COUPLING FROM 0.05 – 10 Nm

www.rwcouplings.com

BACKLASH FREE MINIATURE BELLOWS COUPLINGS

Applications:

Ideal for precise angular motion and torque.
Used with the following:

- Optical encoders
- Potentiometers
- Tachometers
- Small servo motors
- Stepper motors
- Measurement systems

Properties of the product range:

- zero backlash
- torsionally rigid
- precise transmission of angular motion and torque
- infinite life
- wear and maintenance free
- compensates for axial, angular and lateral misalignment
- easy assembly

MODELS

PROPERTIES

APPLICATION EXAMPLES

MK1



**with radial set screws
from 0.05-10 Nm**

- cost effective design
- integrated „dismounting groove“
- a mounting groove or flattening of the shaft is not required

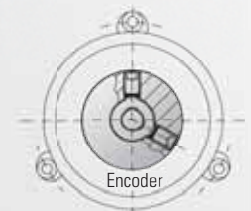
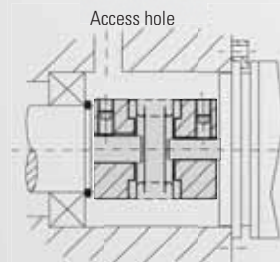

see page 4

MK 2



**with clamping hub
from 0.5-10 Nm**

- easy assembly
- for highly dynamic applications
- finely balanced up to 90,000 rpm available

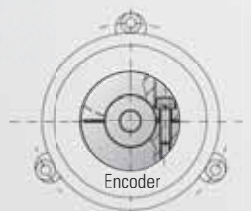
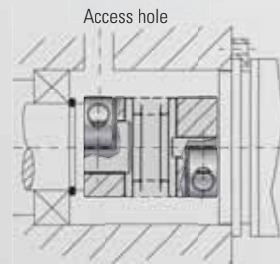

see page 5

MK 3



**with expanding shaft
from 0.5-10 Nm**

- compact design
- for hollow shaft mounting
- saves assembly space and cost

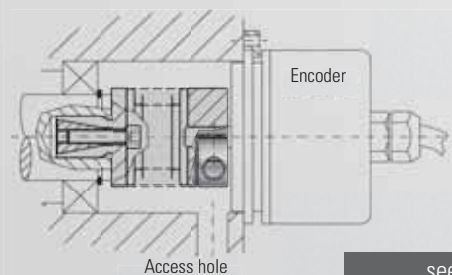

Encoder

Access hole

see page 6

MK 4



**with radial set screws
from 0.5-10 Nm**

- blind-mate press-fit design
- electrically + thermally insulated
- integrated „dismounting groove“
- a mounting groove or flattening of the shaft is not required
- easy assembly

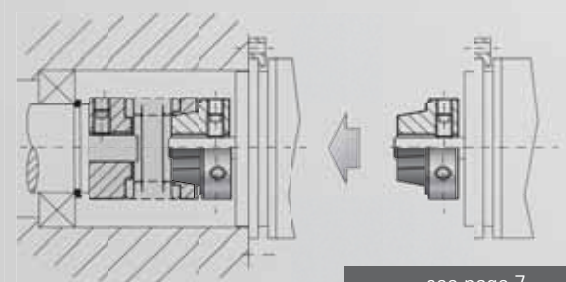

see page 7

optional
stainless steel

MODELS

PROPERTIES

APPLICATION EXAMPLES

MK 5



with clamping hub
from 0.5-10 Nm

- blind-mate press-fit design
- electrically + thermally insulated
- easy assembly

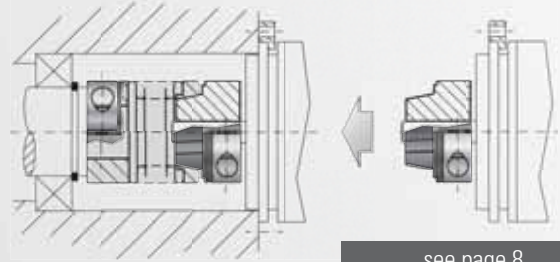

see page 8

MK 6



with clamp hub and expanding shaft
from 0.5-10 Nm

- blind mate press-fit design
- compact design
- for hollow shaft connections
- saves assembly space and cost
- easy assembly

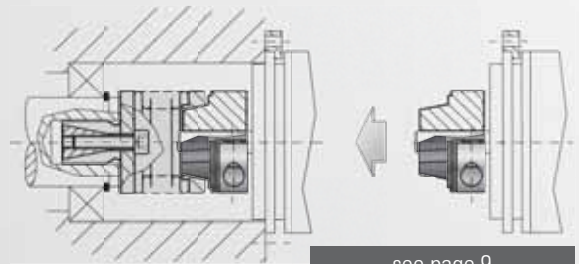

see page 9

BKL 003



with clamping hub
up to 3 Nm

- extremely cost effective
- easy assembly
- temperature range up to 200°C

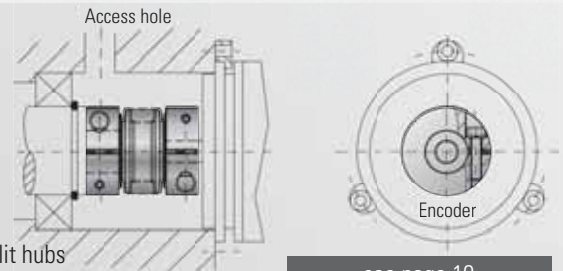

miniature bellows coupling with split hubs

see page 10

MK Special design



miniature bellows coupling with integrated spindle

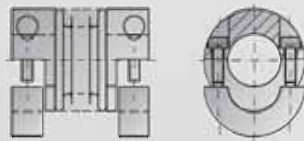

miniature bellows coupling with integrated „sun“ gear



miniature line shaft



miniature bellows coupling with special bellow

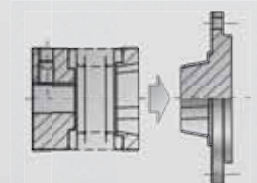

blind-mate coupling with special male segment



MODEL MK1

TECHNICAL SPECIFICATIONS

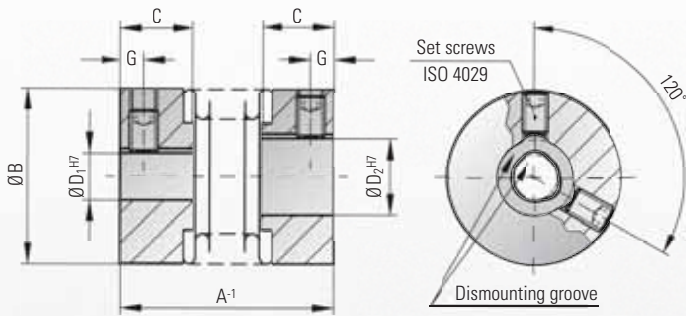

common solutions:

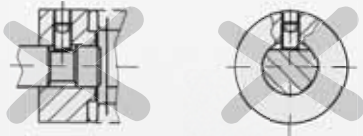

Ordering example

MK1 / 5 / 26 / 4 / 5 / XX

Model
Series/Nm
Overall length
Ø D1 H7
Ø D2 H7
Non standard



with radial clamping screw

Properties:

- backlash-free and torsionally rigid
- low-cost design
- low moment of inertia
- compensates for 3-axis of misalignment
- a mounting groove or flattening of the shaft is not required due to the integrated dismounting groove

Material:

Bellows are made of highly flexible high-grade stainless steel, hubs from aluminium.

Design:

Hubs with DIN 916 radial set screw and **integral dismounting groove**.

Temperature range:

-30 to +110° C (3.6 F to 230),

Speeds:

Up to 20,000 rpm, in excess of 20,000 rpm available with balanced version

Service life:

These couplings have an infinite service life, and are maintenance free, if the technical limits are not exceeded.

Fit tolerance:

On the hub/shaft connection 0.01 to 0.08 mm.

Non-standard application:

Custom designs with varied tolerances, keyways, non-standard material and bellows are available upon request.

Model MK 1		Series																	
		0.5		1		5			10			15		20		45		100	
Rated torque (Nm)	T_{KN}	0.05	0.1	0.5	1.0			1.5	2.0		4.5	10							
Overall length (mm)	A	14	20	20	23	26	22	25	28	24	29	26	31	35	37	45	43	53	
Outer diameter (mm)	B	6.5	10	15			15			19		25		32		40			
Fit length of hub (mm)	C	4	5	6.5			6.5			7.5		11		13		15			
Special bores from Ø to Ø H7 (mm)	$D_{1/2}$	1-3	1-5	3-9			3-9			3-12		3-16		6-22		6-28			
Standard bore H7 (mm)	$D_{1/2}$	2	3	6			6			6/10		6/10		10		10			
Clamping screw ISO 4029		1xM2	1xM2.5	1xM3			1xM3			2xM3		2xM4		2xM5		2xM6			
Tightening torque of the assembly screws (Nm)	E	0.35	0.75	1.3			1.3			1.3		2.5		4		6			
Distance (mm)	G	1.5	1.8	2			2			2		2.5		3.5		4			
Mass moment of inertia (gcm ²)	J	0.1	0.4	1.1	1.2	1.3	1.3	1.8	2	4.7	5.5	15	18	20	65	70	180	220	
Weight (g)		1	5	6	6	6	6	7	8	12	14	22	24	26	54	58	106	114	
Torsional stiffness (Nm/rad)	C_T	50	70	280	210	170	510	380	320	750	700	1200	1300	1200	7000	5000	9050	8800	
axial	Max. values	0.4		0.4	0.4	0.5	0.6	0.4	0.5	0.6	0.5	0.7	0.5	0.6	0.7	0.7	1	1	1.2
lateral		0.1		0.15	0.15	0.2	0.25	0.15	0.2	0.25	0.15	0.2	0.15	0.2	0.25	0.2	0.25	0.2	0.3
angular		1		1	1	1.5	2	1	1.5	2	1.5	1.5	1.5	1.5	2	1.5	2	1.5	2

Integral dismounting groove from bore diameter 4 mm and larger. (1 Nm = 8.85 in lbs)



MODEL MK2

TECHNICAL SPECIFICATIONS

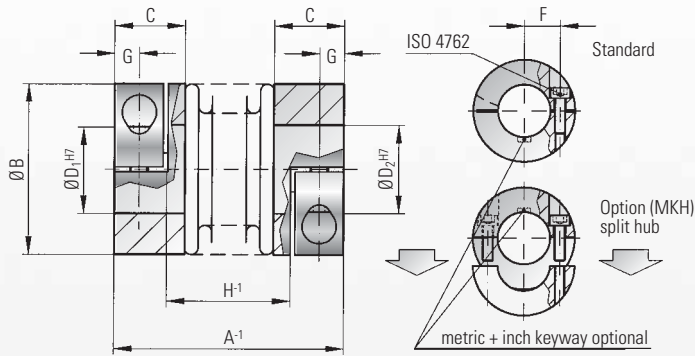

Ordering example

MK2 / 5 / 25 / 4 / 5 / XX

Model
Series/Nm
Overall length
Ø D1 H7
Ø D2 H7
Non standard

MKH = split hub



with clamping hubs

Properties:

- frictional connection utilizing clamping hubs
- for high dynamic applications
- backlash-free and torsionally rigid
- low moment of inertia
- compensates for 3-axis of misalignment

Material:

Bellows are made of highly flexible high-grade stainless steel, hubs from aluminium.

Design:

Standard: With a single radial clamping screw per hub ISO 4762

Option (MKH): Both clamping hubs completely removable

Temperature range:

-30°C to +110°C (3,6 F to 230 F)

Speeds:

Up to 10,000 rpm, in excess of 10,000 rpm with balanced version.

Service life:

These couplings have an infinite life, and are maintenance-free if the technical ratings are not exceeded.

Fit tolerance:

On the hub/shaft connection 0.01 to 0.05 mm.

Non-standard application:

Custom designs with varied tolerances, keyways, non-standard material and bellows are available upon request.

Model MK 2		Series															
		5			10			15		20			45		100		
Rated torque (Nm)	T_{KN}	0.5			1.0			1.5		2.0			4.5		10		
Overall length (mm)	A	25	28	31	27	30	33	30	35	35	40	44	46	54	50	60	
Outer diameter (mm)	B	15			15			19		25			32		40		
Fit length of hub (mm)	C	9			9			11		13			16		16		
Special bores from Ø to Ø H7 (mm)	$D_{1/2}$	3-7			3-7			3-8		3-12.7			5-16		5-24		
Standard bore H7 (mm)	$D_{1/2}$	6			6			6		6/10			10		10		
Screws ISO 4762		M2			M2			M2.5		M3			M4		M4		
Tightening torque of the assembly screws (Nm)	E	0.43			0.43			0.85		2.3			4		4.5		
Distance between centers (mm)	F	4.5			4.5			6		8			10		15		
Distance (mm)	G	3			3			3.5		4			5		5		
Distance (H)	H	12	15	18	14	17	20	14.5	19.5	17	22	26	23.5	31.5	27.5	37.5	
Mass moment of inertia (gcm ²)	J_{ges}	2.6	2.8	3	3	3.4	3.6	8.5	9.5	25	27	29	100	108	160	205	
Weight (g)		9	9	9	9	10	11	22	24	36	38	40	74	78	120	130	
Torsional stiffness (Nm/rad)	C_T	280	210	170	510	380	320	750	700	1200	1300	1200	7000	5000	9050	8800	
axial	Max. values	0.4	0.5	0.6	0.4	0.5	0.6	0.5	0.7	0.5	0.6	0.7	0.7	1	1	1.2	
lateral		0.15	0.2	0.25	0.15	0.2	0.25	0.15	0.2	0.15	0.2	0.25	0.2	0.25	0.2	0.3	
angular		(degrees)	1	1.5	2	1	1.5	2	1.5	1.5	1.5	1.5	2	1.5	2	1.5	2

1 Nm = 8,85 in lbs



MODEL MK3

TECHNICAL SPECIFICATIONS

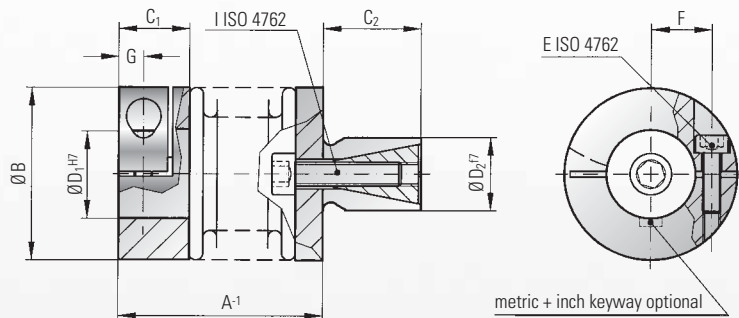

Ordering example

MK3 / 20 / 36 / 6 / 12 / XX

Model
Series/Nm
Overall length
Ø D1 H7
Ø D2 f7
Non standard



with expanding shaft

Properties:

- compact design, conserves space while saving cost
- easy mounting
- backlash-free and torsionally rigid
- low moment of inertia
- compensates for 3-axis of misalignment

Material:

Bellows are made of highly flexible high-grade stainless steel, clamping hub aluminium. Expanding hub and cone (steel).

Design:

On one side with a single radial clamping screw ISO 4762. On one side an expanding shaft with tapered clamping element

Temperature range:

-30° to +110° C (3,6 F to 230 F)

Speeds:

Up to 10,000 rpm, in excess of 10,000 rpm available with balanced version.

Service life:

These coupling have an infinite life, and are maintenance-free if the technical ratings are not exceeded.

Fit tolerance:

On the hub/shaft connection 0.01 to 0.05 mm.

Non-standard application:

Custom designs with varied tolerances, keyways, non-standard material and bellows are available upon request.

Model MK 3	Series															
	5			10			15		20			45		100		
Rated torque (Nm)	T _{KN}	0.5			1			1.5		2			4.5		10	
Overall length (mm)	A	20	23	26	22	25	28	24	30	27	33	36	36	44	41	51
Outer diameter (mm)	B	15			15			19		25			32		40	
Fit length (mm)	C ₁	9			9			11		13			16		16	
Shaft length (mm)	C ₂	10			10			12		12			15		20	
Special bores from Ø to Ø H7 (mm)	D ₁	3-7			3-7			4-8		4-12.7			5-16		6-24	
Standard bore H7 (mm)	D ₁	6			6			6		6/10			10		10	
Standard shaft f7 (mm)	D ₂	8			8			10		12			14		16	
Screws ISO 4762		M2			M2			M2.5		M3			M4		M4	
Tightening torque of the assembly screws (Nm)	E	0.43			0.43			0.85		2.3			4		4.5	
Distance between centers (mm)	F	4.5			4.5			6		8			10		15	
Distance (mm)	G	3			3			3.5		4			5		5	
Screws ISO 4762		M3			M3			M4		M4			M5		M6	
Tightening torque of the assembly screws (Nm)	I	1.5			1.5			3		4			6.5		11	
Mass moment of inertia (gcm ²)	J	2.6	2.8	3.0	3.0	3.4	3.6	8.5	9.5	25	27	29	100	108	160	205
Torsional stiffness (Nm/rad)	C _T	280	210	170	510	380	320	750	700	1200	1300	1200	7000	5000	9050	8800
axial	Max. values	0.4	0.5	0.6	0.4	0.5	0.6	0.5	0.7	0.5	0.6	0.7	0.7	1	1	1.2
lateral		0.15	0.2	0.25	0.15	0.2	0.25	0.15	0.2	0.15	0.2	0.25	0.2	0.25	0.2	0.3
angular		1	1.5	2	1	1.5	2	1.5	1.5	1.5	1.5	2	1.5	2	1.5	2

Missing hub measurements see MK 2. (1 Nm = 8.85 in lbs)

optional
stainless steel

MODEL MK4

TECHNICAL SPECIFICATIONS



Press-fit precision metal bellows couplings

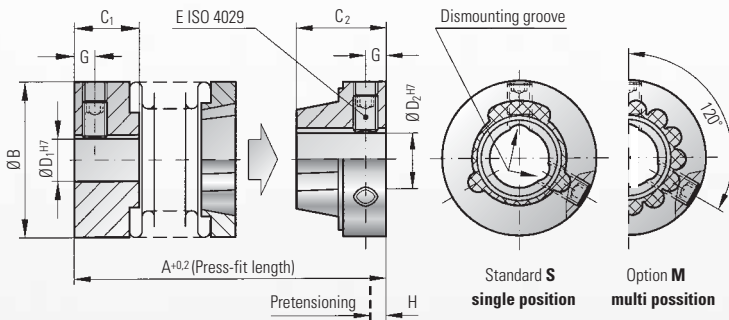

Properties:

- electrically insulated
- no wear
- easy mounting and dismounting
- absolutely backlash-free and torsionally rigid
- low moment of inertia
- compensates for 3-axis of misalignment

Material:

Bellows made of highly flexible high-grade stainless steel; clamping hubs and tapered female segment on bellows face from aluminium. Tapered segment on the hub face: glass-fiber reinforced plastic deposited onto an aluminium hub.

Design:

Both hubs have radial set screws and integral dismounting grooves. Incorporates a blind mate press-fit connection.

Temperature range:

-30° to +110°C (3,6 F to 230 F)

Speeds:

Up to 20,000 rpm, in excess of 20,000 rpm available with balanced version

Service life:

These couplings have an infinite life, and are main-tenance-free if the technical ratings are not exceeded.

Fit tolerance:

On the hub/shaft connection 0.01 to 0.08 mm.

Non-standard application:

Custom designs with varied tolerances, keyways, non-standard material and bellows are available upon request.

Ordering example

MK4/20 / 37 / 8 / 10 / XX

Model
Series/Nm
Overall length
Ø D1 H7
Ø D2 H7
Non standard e.g. Option M

Model MK 4		Series											
		5			15		20			45		100	
Rated torque (Nm)	T_{KN}	0.5			1.5		2			4.5		10	
Overall length without any pretensioning (mm)	A	22	25	28	26	31	28	33	37	39	47	46	56
Outer diameter (mm)	B	15			19		25			32		40	
Fit length (mm)	C_1	6.5			7.5		11			13		15	
Fit length (mm)	C_2	9			10		11			14		16	
Special bores from Ø to Ø H7 (mm)	D_1	3-9			3-12		3-16			6-22		6-28	
Special bores from Ø to Ø H7 (mm)	D_2	3-6.35			3-9		3-12.7			6-16		6-20	
Standard bore H7 (mm)	$D_{1/2}$	6			6		6/10			10		10	
Screws ISO 4029		1xM3			2xM3		2xM4			2xM5		2xM6	
Tightening torque of the assembly screws (Nm)	E	1.3			1.3		2.5			4		6	
Distance (mm)	G	2			2		2.5			3.5		4	
Pretensioning approx. (mm)	H	0.4			0.5		0.5			0.7		1	
Axial recovery force of coupling (N)		5	3	2	4	3	3	4	3	15	10	33	46
Mass moment of inertia (gcm ²)	J_{GES}	2.0	2.2	2.5	5.5	6.0	21	23	25	80	85	200	210
Torsional stiffness (Nm/rad)	C_T	280	210	170	750	700	1200	1300	1200	7000	5000	9050	8800
axial (mm)	Max. values	0.4	0.5	0.6	0.5	0.7	0.5	0.6	0.7	0.7	1	1	1.2
lateral (mm)		0.15	0.2	0.25	0.15	0.2	0.15	0.2	0.25	0.2	0.25	0.2	0.3
angular (degrees)		1	1.5	2	1.5	1.5	1.5	1.5	2	1.5	2	1.5	2

Integrated dismounting groove from bore diameter 4 mm and larger. (1 Nm = 8.85 in lbs)



MODEL MK5

TECHNICAL SPECIFICATIONS



Press-fit precision metal bellows couplings

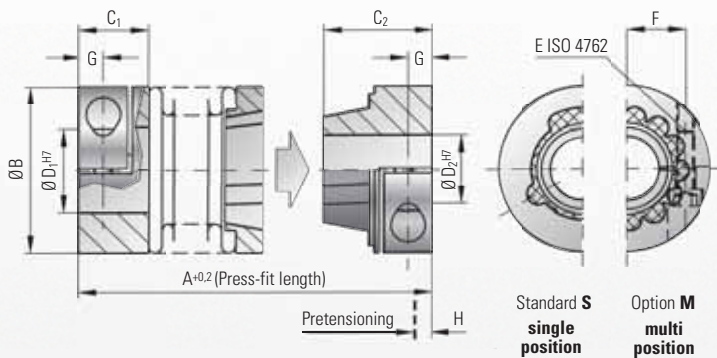

Properties:

- electrically insulated
- no wear
- easy mounting and dismounting
- absolutely backlash-free and torsionally rigid
- low moment of inertia
- compensates for 3-axis of misalignment

Material:

Bellows made of highly flexible high-grade stainless steel, the clamping hubs and tapered female segment on the bellows face are aluminium. Tapered segment on the hub face: glass-fiber reinforced plastic deposited onto an aluminium hub.

Design:

With a single radial clamping screw per hub ISO 4762. Backlash-free, blind mate press-fit connection

Temperature range:

-30° to +110° C (3,6 F to 230 F)

Speed:

Up to 10,000 rpm, over 10,000 rpm available with balanced version.

Service life:

These couplings have an infinite life and are maintenance-free if the technical ratings are not exceeded.

Fit tolerance:

On the hub/shaft connection 0.01 to 0.05 mm.

Non-standard applications:

Custom designs with varied tolerances, keyways, non-standard material and bellows are available upon request.

Ordering example

MK5 / 20 / 37 / 6 / 10 / XX

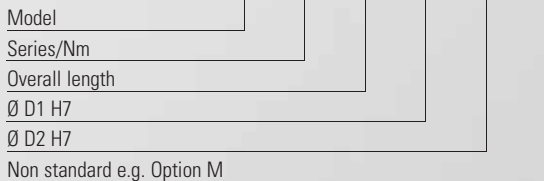

Model MK 5		Series											
		5			15		20			45		100	
Rated torque (Nm)	T _{KN}	0.5			1.5		2			4.5		10	
Overall length without any pretensioning (mm)	A	27	30	33	34	39	37	43	46	49	57	55	65
Outer diameter (mm)	B	15			19		25			32		40	
Fit length (mm)	C ₁	9			11		13			16		16	
Fit length (mm)	C ₂	12			14		16			20		21.5	
Non-standard bore from Ø to Ø H7 (mm)	D _{1/2}	3-6.35			3-8		3-12.7			5-16		5-20 (D ₁ -24)	
Standard bore H7 (mm)	D _{1/2}	6			6		6/10			10		10	
Screws ISO 4762	E	M2			M2.5		M3			M4		M4	
Tightening torque of the assembly screws (Nm)	E	0.43			0.85		2.3			4		4.5	
Distance between centers (mm)	F	4.5			6		8			10		15	
Distance (mm)	G	3			3.5		4			5		5	
Pretensioning approx. (mm)	H	0.4			0.5		0.5			0.7		1	
Axial recovery force of coupling (N)		5	3	2	4	3	3	4	3	15	10	33	46
Mass moment of inertia (gcm ²)	J _{ges}	3.0	3.2	3.5	9.0	10	28	30	33	110	120	220	230
Torsional stiffness (Nm/rad)	C _T	280	210	170	750	700	1200	1300	1200	7000	5000	9050	8800
axial	Max. values	0.4	0.5	0.6	0.5	0.7	0.5	0.6	0.7	0.7	1	1	1.2
lateral		0.15	0.2	0.25	0.15	0.2	0.15	0.2	0.25	0.2	0.25	0.2	0.3
angular		1	1.5	2	1.5	1.5	1.5	1.5	2	1.5	2	1.5	2

optional
stainless
steel

MODEL MK6

TECHNICAL SPECIFICATIONS



Press-fit precision metal bellows couplings

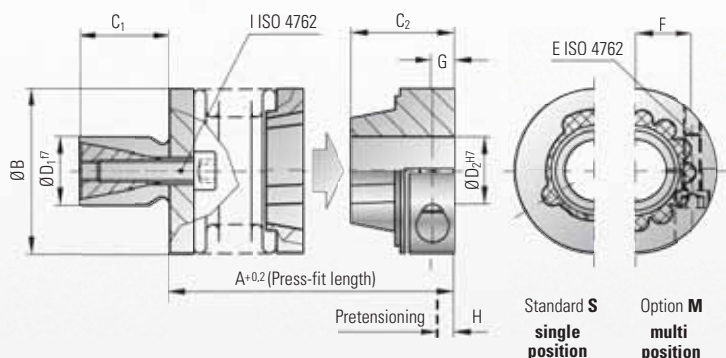

Properties:

- electrically insulated
- self-adjusting
- no wear
- easy mounting and dismantling
- backlash-free and torsionally rigid
- low moment of inertia
- compensates for 3-axis of misalignment

Material:

Bellows made of highly flexible high-grade stainless steel, clamping hub aluminium. Expanding hub and cone (steel)

Design:

On one side an expanding shaft with tapered clamping element. On one side a clamping hub. Backlash-free, blind mate press-fit connection (glass-fiber reinforced plastic)

Temperature range:

-30° to +110° C (3,6 F to 230 F),

Speed:

Up to 10,000 rpm, in excess of 10,000 rpm available with balanced version

Service life:

These couplings have an infinite life, and are maintenance-free if the technical ratings are not exceeded.

Fit tolerance:

On the hub/shaft connection 0.01 to 0.05 mm.

Ordering example

MK6/20 / 28 / 12 / 12 / XX

Model
Series/Nm
Overall length (mm)
Shaft Ø D1 f7
Bore Ø D2 H7
non standard e.g. Option M

Model MK 6		Series											
		5			15		20			45		100	
Rated torque (Nm)	T _{KN}	0.5			1.5		2			4.5		10	
Length without pretensioning (mm)	A	21	24	27	27	32	28	34	38	38	46	45	55
Outer diameter (mm)	B	15			19		25			32		40	
Shaft length (mm)	C ₁	10			12		12			15		20	
Standard shaft Ø f7 (mm)	D ₁	8			10		12			14		16	
Fit length (mm)	C ₂	12			14		16			20		21.5	
Special bores from Ø to Ø H7 (mm)	D ₂	3-6.35			3-8		3-12.7			5-16		5-20	
Standard bore H7 (mm)	D ₂	6			6		6/10			10		10	
ISO 4762 screws		M2			M2.5		M3			M4		M4	
Tightening torque of the assembly screws (Nm)	E	0.43			0.85		2.3			4		4.5	
Distance between centers (mm)	F	4.5			6		8			10		15	
Distance (mm)	G	3			3.5		4			5		5	
Pretensioning approx. (mm)	H	0.4			0.5		0.5			0.7		1	
ISO 4762 screws		M3			M4		M4			M5		M6	
Tightening torque of the assembly screws (Nm)	I	1.5			3		4			6.5		11	
Axial recovery force (N)		5	3	2	4	3	3	4	3	15	10	33	46
Mass moment of inertia (gcm ²)	J _{gBS}	3.0	3.2	3.5	9.0	10	28	30	33	110	120	220	230
Torsional stiffness (Nm/rad)	C _T	280	210	170	750	700	1200	1300	1200	7000	5000	9050	8800
lateral (mm)	Max. values	0.15	0.2	0.25	0.15	0.2	0.15	0.2	0.25	0.2	0.25	0.2	0.3
angular (degrees)		1	1.5	2	1.5	1.5	1.5	1.5	2	1.5	2	1.5	2



MODEL BKL 003

TECHNICAL SPECIFICATIONS

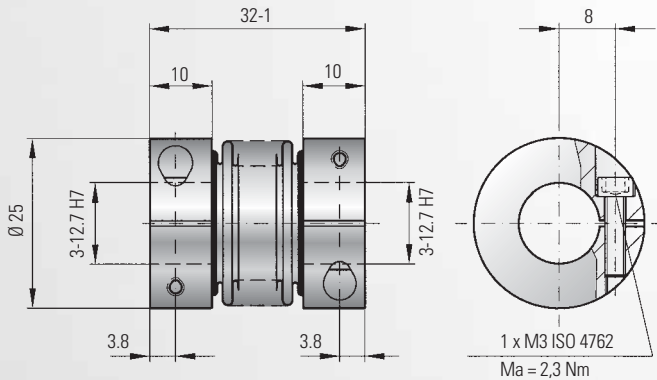

Ordering example

BKL/ 003 / 3 / 5 / XX

Model
Series/Nm
Bore Ø D1 H7
Bore Ø D2 H7
Non standard



ECOFLEX®

Properties:

- low cost
- backlash-free and torsionally rigid
- compensates for 3-axis of misalignment

Material:

Bellows are made of highly flexible high-grade stainless steel, hubs of aluminium.

Design:

With a single radial clamping screw per hub ISO 4762
Available design split hub (option H): Both clamping hubs completely removable

Temperature range:

-40 to +200° C (-3.6 to 392 F)

Torque:

3 Nm

Speed:

Up to 10,000 rpm, in excess of 10,000 rpm with balanced version.

Compensation of misalignment:

Lateral misalignment up to 0,2 mm
Axial misalignment up to 1 mm
Angular misalignment up to 2° degree

ECOFLEX®: The low cost alternative for shaft encoders, potentiometer, stepper motors and small servo drives.

Possible bore diameter

3	4	4.76	5	6	6.35	7	8	9	9.53	10	11	12	12.7
---	---	------	---	---	------	---	---	---	------	----	----	----	------

Bore size up to 16 mm available with special hub.

Assembly instructions

Assembly preparation:

During assembly and disassembly the bellows can only be stretched or deformed by 1.5 times the stated catalog values. The shafts and couplings bores must be clean and free of burrs, nicks, and deformations. Double check the shaft and bore dimensions and tolerances to ensure a proper fit. R+W couplings are bored to an ISO H7 tolerance. The clearance between hub and the bore should be no more than 0.01

to 0.05 mm to ensure a proper fit and clamping strength.

A slight film of oil on the shaft will aid in the assembly and disassembly of the coupling without compromising the strength of the coupling.

Important! "Oil and grease with molybdenum disulfide or other high pressure additives, as well as sliding greases, should not be used."

Set Screw mounting instructions models MK 1 and MK 4

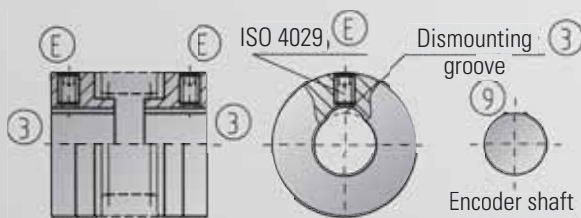

Assembly:

Slide the coupling onto the shaft of the drive element and position it in place. Tighten the set screw (E) using a torque wrench to the proper torque value listed in the table above. Slide the shaft of the driven element (an encoder for example) into the coupling bore to its proper position. Tighten the second set screw (E) using a torque wrench to the proper torque value.

Series 1 - 10: 1 set screw per hub

Series 15 - 100: 2 set screws per hub set 120 degree apart

Disassembly:

Disassembly is very easy with R+W coupling. Simply loosen the set screw (E) and slide the coupling off the shaft. R+W has incorporated a disassembly groove (3) into the coupling design so that clearance is provided for the set screw "burr" (9).

A mounting groove or flattening of the shaft is not required



ASSEMBLY INSTRUCTIONS

SINGLE SCREW CLAMPING HUB DESIGN, MODEL MK 2 / MK 5 / BKL 003

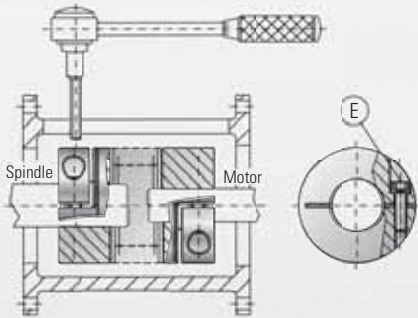

Assembly:

Slide the coupling onto the drive element (a motor for example) to the proper axial position. Using a torque wrench tighten the mounting screw (E) to the proper tightening torque listed in the table on the previous page. Slide the driven element (a spindle or encoder for example) into the coupling to its proper axial position and tighten the mounting screw by doing the same as before.

Disassembly:

Simply loosen the mounting screws (E) and remove the coupling.

Expanding shaft design, Model MK 3 / MK 6

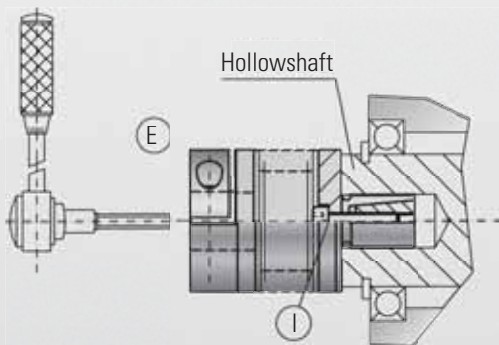

Assembly:

Completely insert the expanding shaft of the coupling into the hollow bore until it fits. Using a torque wrench tighten the mounting screw (I) to the proper torque value listed in the table on the previous page. Insert the shaft into the other end of the coupling to its proper position. Tighten mounting screw (a) to the proper torque value with a torque wrench.

Disassembly:

Simply loosen the mounting screws (E) and (I) and remove the coupling. The expanding shaft connection can be loosened by partially unscrewing the mounting screw (I) and applying axial pressure to it.

Pretensioning of the press-fit coupling design, Model MK 4 / MK 5 / MK 6

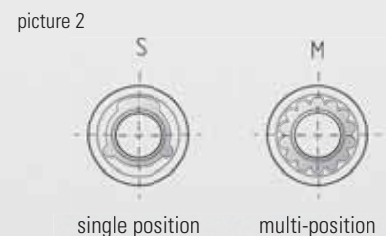
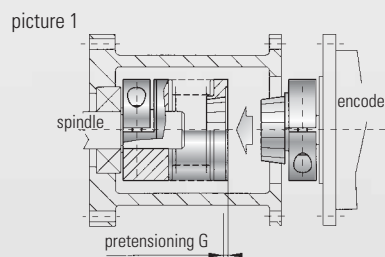
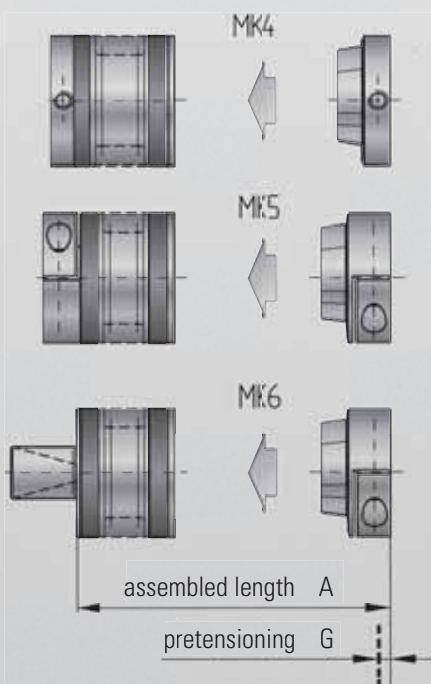

Assembly:

Important! It is extremely important that the overall length of the assembled coupling is noted and taken into consideration of the assembly process. Models MK 4, MK 5 and MK 6 are blind mate press-fit couplings. They will provide absolute backlash free operation only if they are properly pretensioned. Mount the female segment of the coupling onto the driven element. Next loosely mount the male segment onto the drive element so that it slides with friction on the shaft. Mount the drive element onto the coupling flange (picture 1). Remove the drive element from the flange and note the position of the male coupling segment. Slide the male coupling segment towards into the female segment till distance (G) (Pre-tension distance) and tighten the mounting screws. Proper torque values are given in the table on the previous page. Two versions of the blind mate coupling are available, the single position and the multi position (picture 2).

**Experience and
 Know-how
 for your special
 requirements.**

R+W Antriebselemente GmbH
 Alexander-Wiegand-Straße 8
 D-63911 Klingenberg/Germany

Tel. +49-(0)9372 – 9864-0
 Fax +49-(0)9372 – 9864-20

info@rw-kupplungen.de
 www.rwcouplings.com

**QUALITY
 MANAGEMENT**

We are certified
 according to ISO 9001-200



TGA-ZM-05-91-00
 Registration No. 9605022

The information mentioned in this document is based on our present knowledge and experiences and does not exclude the manufacturer's own substantial testing of the equipment. So this is no obligatory assurance even with regard to protection rights of Third Parties. The sale of our products is subject to our General Conditions of Sale and Delivery.

THE R+W-PRODUCT RANGE



**TORQUE LIMITERS
 Series SK/ST**

From 0.1 – 160,000 Nm, Bore diameters 3 – 290 mm
 Available as a single position, multi-position, load holding, or full disengagement version
 Single piece or press-fit design



**BELLOWS COUPLINGS
 Series BK**

From 2 – 10,000 Nm
 Bore diameters 10 – 180 mm
 Single piece or press-fit design



**LINE SHAFTS
 Series ZA/ZAE**

From 10 – 4,000 Nm
 Bore diameters 10 – 100 mm
 Available up to 6 mtr. length



**MINIATURE BELLOWS COUPLINGS
 Series MK**

From 0.05 – 10 Nm
 Bore diameters 1 – 28 mm
 Single piece or press-fit design



**SERVOMAX®
 ELASTOMER COUPLINGS
 Series EK**

From 2 – 2,000 Nm, Shaft diameters 3 – 80 mm
 backlash-free, press-fit design



**ECOLIGHT®
 ELASTOMER COUPLINGS
 Series TX 1**

From 2 – 810 Nm
 Shaft diameters 3 – 45 mm



**LINEAR COUPLINGS
 Series LK**

From 70 – 2,000 N
 Thread M5 – M16



**POLYAMID COUPLINGS
 MICROFLEX
 Series FK 1**

Rated torque 1 Ncm
 Bore diameters 1 – 1.5 mm