

UNILINE



About Rollon



Development of global business

- 1975** Parent company, Rollon S.r.l., founded in Italy
- 1991** Founding of Rollon GmbH in Germany
- 1995** Expansion of headquarters to new 4,000 m² factory
Assembly starts in Germany
Quality management certified to ISO 9001
- 1998** Rollon B.V. in the Netherlands and Rollon Corporation in the USA are founded
Expansion of German branch to new 1,000 m² plant
- 1999** Founding of Rollon S.A.R.L. in France
Environmental management certified to ISO 14001
- 2000** Rollon s.r.o. founded in the Czech Republic
- 2001** Expansion of headquarters to new 12,000 m² manufacturing plant
- 2007** Restructuring of the GmbH and alignment of production in Germany to customer-specific adaptations
Takeover of the assets of a manufacturer of linear rail systems
- 2008** Expansion of sales network in Eastern Europe and Asia

Continual expansion and optimization of the portfolio

Founded in 1975, Rollon manufactured high-precision linear roller bearings for the machine tool industry. Early on, Rollon started manufacturing linear bearings based on the bearing-cage design. In 1979, the Compact Rail self-aligning linear bearings joined the Telescopic Rail industrial drawer slides and Easy Rail linear bearings and became the basis of the strong foundation on which the company is building upon today. Continuing optimization of these core products still remains one of the most important goals at Rollon. The development of the patented Compact Rail linear bearing, which uses different proprietary rail profiles and high-precision radial ball bearing sliders, enables the compensation of height and angle mounting defects in applications, and is only one example of the continuing efforts to innovative the development of our existing product families. In the same manner, we continually introduce innovative new product families displaying our continuing product development and optimization in the industry. These include:

- 1994 Light Rail - full and partial extension telescopic in lightweight design
- 1996 Uniline - belt driven linear actuators
- 2001 Ecoline - economical aluminum linear actuators
- 2002 X-Rail - inexpensive formed steel linear guides
- 2004 Curviline - curved monorail profile rail guide with roller carriages
- 2007 Monorail - miniature sizes and full sized

Each further innovation of our linear bearings is built upon the our extensive knowledge of the nine product families in production today as well as on the current market demands. Rollon is the ultimate linear technology for any application needs.

Content

1 Product explanation	
Ready-to-install linear axes	5
2 Technical Data	
Performance characteristics and remarks	7
Load ratings, moments and characteristic data	
Type A	8
Type C	10
Type E	12
Type ED	14
Type H	15
3 Product dimensions	
Type A	16
Type A version L with long slider	20
Type A version D with double slider	22
Type C	24
Type C version L with long slider	
Type C version D with double slider	26
Type E	27
Type E version L with long slider	28
Type E version D with double slider	29
Type ED	30
Type ED version L with long slider	31
Type ED version D with double slider	32
Type H	33

4 Accessories

Adapter plates	34
Connection plates	36
Fixing clamp APF-2	37
T-nut, A100 drive shaft	38
A100 conical fitting device AC-10MA01	39

5 Technical information

Static load	40
Calculation formulae	41
Service life	43
Linear accuracy, Repeat accuracy	44
Synchronous use of the linear units in pairs, Linear units with extended strokes, Length and stroke tolerances, Working temperature	45
Lubrication	46
Belt tension	48
Determination of the motor torque, Installation instructions	50

Ordering key

Ordering key with explanations

Portfolio

Product explanation

Uniline is the product family of ready-to-install linear axes



Fig. 1

Uniline is the product family of ready-to-install linear axes. They consist of internal Compact Rail roller sliders and steel-reinforced polyurethane belts in a rigid aluminium profile. Longitudinal seals enclose the system. This arrangement provides the best protection for the axis from soiling and damage. The guide rails are arranged in the four product series in different combinations for a wide range of applications. The use of one or several sliders provides greater variation.

The most important characteristics:

- Compact design
- Protected internal linear guides
- High traversing speeds
- Grease-free operation possible (depending on the application. For further information, please contact our Application Engineering department)
- High versatility
- Long traverses
- Versions with long or several sliders available in one linear axis

Preferred areas of application:

- Handling and automation
- Multi-axis gantries
- Packaging machines
- Cutting machines
- Displaceable panels
- Painting installations
- Welding robots
- Special machines

Type A

In the A series, the fixed bearing rail (T-rail) is mounted horizontally in the aluminium profile. Versions with long (L) or double (D) sliders in one axis are possible.



Fig. 2

Type C

In the C series, the fixed bearing rail (T-rail) and the compensating bearing rail (U-rail) are mounted in the aluminium profile vertically. Versions with long (L) or double (D) sliders in one axis are possible.



Fig. 3

Type E

In the E series, the fixed bearing rail (T-rail) is mounted horizontally in the aluminium profile, and the compensating bearing rail (U-rail) is flanged to the profile on the outside as moment support. Versions with long (L) or double (D) sliders in one axis are possible.



Fig. 4

Type ED

In the ED series, a compensating bearing rail (U-rail) is mounted horizontally in the aluminium profile, and, for increased moment support, two further compensating bearing rails (U-rail) are flanged to the profile externally. Versions with long (L) or double (D) sliders in one axis are possible.



Fig. 5

Type H

In the H series, the compensating bearing rail (U-rail) is mounted horizontally in the aluminium profile. The H series is used as compensating bearing axis for load absorption of radial forces and, in combination with the other series, as support bearing for the resulting moments. Versions with long (L) or double (D) sliders in one axis are possible.



Fig. 6

Technical data

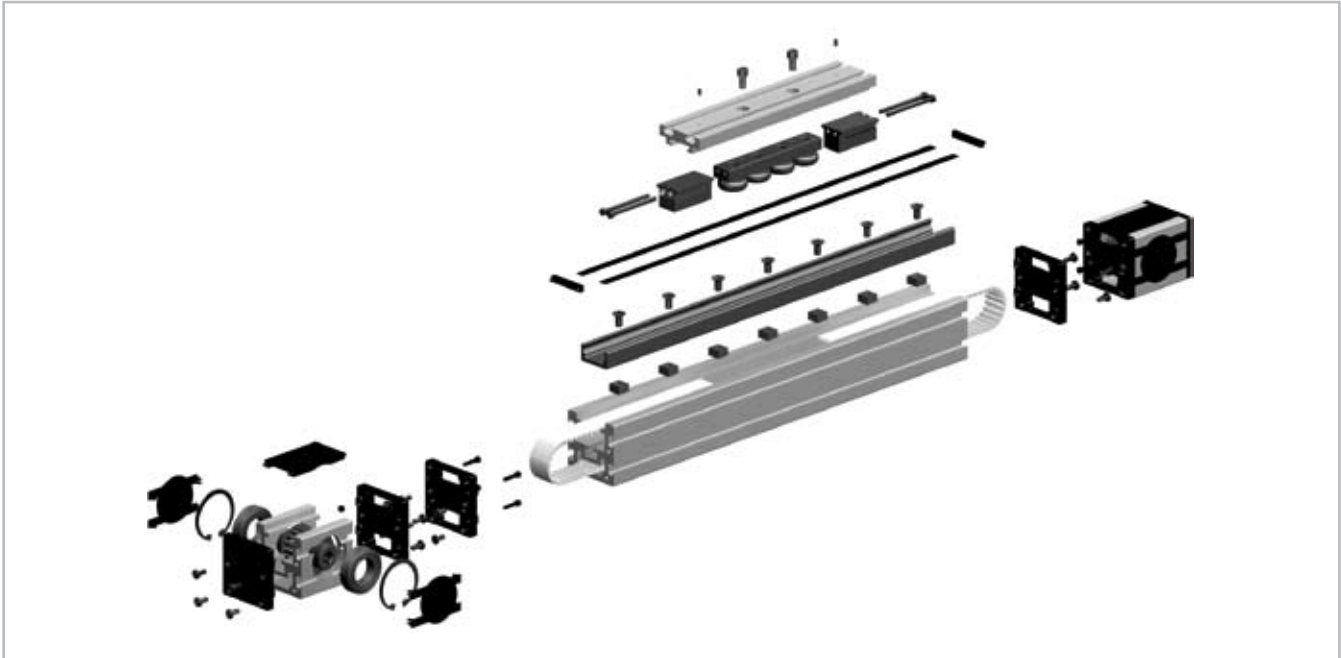

Fig. 7

Performance characteristics:

- Available sizes:
 - Type A: 40, 55, 75, 100
 - Types C and E: 55, 75
 - Type ED: 75
 - Type H: 40, 55, 75
- Max. traversing speed: 9 m/s (354 in/s)
(depending on the application)
- Temperature range: -20 °C to +80 °C (-4 °F to 176 °F)
- Max. traverse in a profile: 5,600 mm (220.47 in)
(depending on the application, size and slider selection)
- Repeat accuracy: 0.1mm (0.004 in)
- Linear guiding accuracy: 0.8 mm (0.032 in)
- Length and stroke tolerances:
 - For strokes <1 m: +0 mm to +10 mm (+0 in to 0.4 in)
 - For strokes >1 m: +0 mm to +15 mm (+0 in to 0.59 in)

Remarks:

- Different adapter plates for mounting with motor and gearbox
- Versions with long or several sliders in one linear axis available
- Different connection bores and clutches available for the motor shaft
- Linear axes with longer strokes (combined linear axes) possible
- Please specify if you want to use the linear axes in pairs by means of a synchronous shaft
- The max. load in vertical use depends on the standard belt tension

Load ratings, moments and characteristic data

Type A

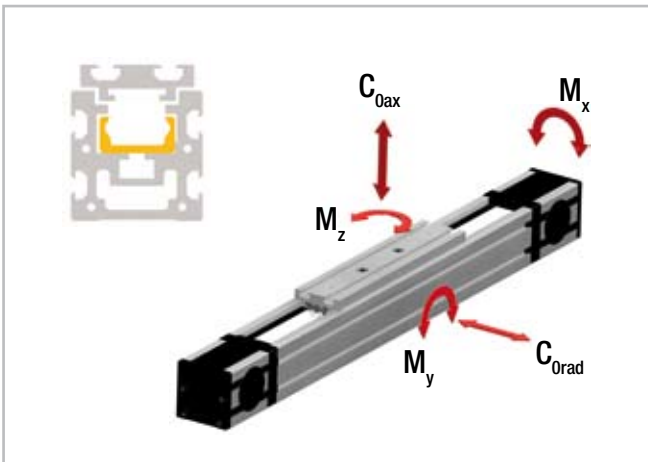

Fig. 8

Type	C [N]	C _{0rad} [N]	C _{0ax} [N]	M _x [Nm]	M _y [Nm]	M _z [Nm]
A40	1530	820	300	2.8	5.6	13.1
A40-L*	3060	1640	600	5.6	22 to 70	61 to 192
A40-D*	3060	1640	600	5.6	70 to 570	193 to 1558
A55	4260	2175	750	11.5	21.7	54.4
A55-L*	8520	4350	1500	23	82 to 225	239 to 652
A55-D*	8520	4350	1500	23	225 to 2302	652 to 6677
A75	12280	5500	1855	43.6	81.5	209
A75-L*	24560	11000	3710	87.2	287 to 770	852 to 2282
A75-D*	24560	11000	3710	87.2	771 to 6336	2288 to 18788
A100	30750	12500	7200	250	250	600
A100-L*	30750	12500	7200	250	500	1200
A100-D*	61500	25000	14400	500	2851 to 24451	4950 to 42450

* Note: For the dimensions of the different models, please refer to chapter 3 Product dimensions, p. 16ff
For the calculation of the allowed moments, please observe pages 41ff

Tab. 1

Characteristic data	Type			
	A40	A55	A75	A100
Standard belt tension [N]	160	220	800	1000
Moment at no load [Nm]	0.14	0.22	1.15	2.3
Max. traversing speed [m/s]	3	5	7	9
Max. acceleration [m/s ²]	10	15	15	20
Repeat accuracy [mm]	0.1	0.1	0.1	0.1
Compact Rail guiding rail	TLV18	TLV28	TLV43	TLV63
Slider type	CS18 spec.	CS28 spec.	CS43 spec.	CS63 spez.
Moment of inertia I _y [cm ⁴]	12	34.6	127	500
Moment of inertia I _z [cm ⁴]	13.6	41.7	172	400
Pitch diameter of pulley [m]	0.02706	0.04138	0.05093	0.06048
Moment of inertia of each pulley [gmm ²]	5055	45633	139969	330000
Stroke per shaft revolution [mm]	85	130	160	190
Mass of slider [g]	220	475	1242	4200
Weight with zero stroke [g]	1459	2897	6729	12700
Weight with 1 m stroke [g]	3465	4505	9751	15950
Belt length [m]	2 x stroke + 0.515	2 x stroke + 0.63	2 x stroke + 0.792	2 x stroke + 0.8
Mass of belt [g/m]	41	74	185	220

Tab. 2

Type C

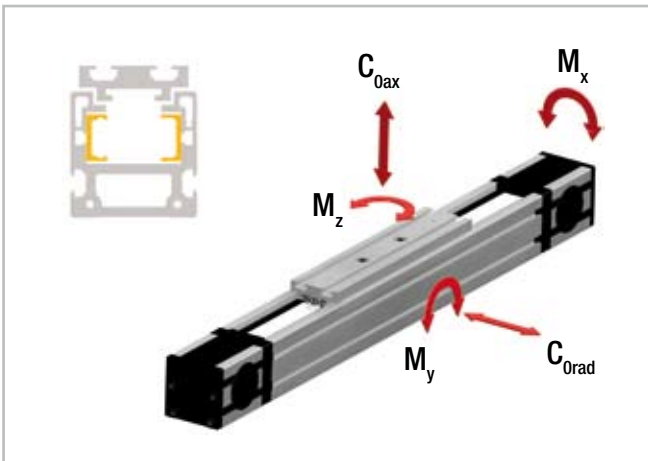

Fig. 9

Type	C [N]	C _{Orad} [N]	C _{0ax} [N]	M _x [Nm]	M _y [Nm]	M _z [Nm]
C55	560	300	1640	18.5	65.6	11.7
C55-L*	1120	600	3280	37	213 to 525	39 to 96
C55-D*	1120	600	3280	37	492 to 3034	90 to 555
C75	1470	750	4350	85.2	217	36.1
C75-L*	2940	1500	8700	170.4	674 to 1805	116 bis 311
C75-D*	2940	1500	8700	170.4	1809 to 13154	312 to 2268

* Note: For the dimensions of the different models, please refer to chapter 3 Product dimensions, p. 16ff
For the calculation of the allowed moments, please observe pages 41ff

Tab. 3

Characteristic data	Type	
	C55	C75
Standard belt tension [N]	220	800
Moment at no load [Nm]	0.3	1.3
Max. traversing speed [m/s]	3	5
Max. acceleration [m/s ²]	10	15
Repeat accuracy [mm]	0.1	0.1
Compact Rail guiding rail	TLV18 / ULV18	TLV28 / ULV28
Slider type	2 CS18 spec.	2 CS28 spec.
Moment of inertia I _y [cm ⁴]	34.4	108
Moment of inertia I _z [cm ⁴]	45.5	155
Pitch diameter of pulley [m]	0.04138	0.05093
Moment of inertia of each pulley [gmm ²]	45633	139969
Stroke per shaft revolution [mm]	130	160
Mass of slider [g]	549	1666
Weight with zero stroke [g]	2971	6853
Weight with 1 m stroke [g]	4605	9151
Belt length [m]	2 x stroke + 0.63	2 x stroke + 0.792
Mass of belt [g/m]	74	185

Tab. 4

Type E

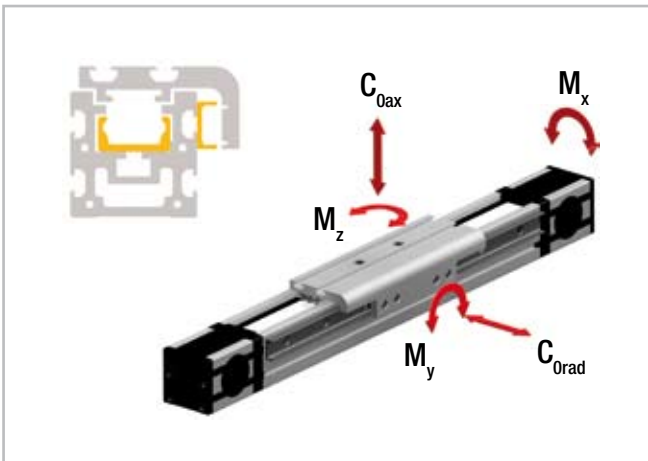

Fig. 10

Type	C [N]	C _{Orad} [N]	C _{0ax} [N]	M _x [Nm]	M _y [Nm]	M _z [Nm]
E55	4260	2175	1500	25.5	43.4	54.4
E55-L*	8520	4350	3000	51	165 to 450	239 to 652
E55-D*	8520	4350	3000	51	450 to 4605	652 to 6677
E75	12280	5500	3710	85.5	163	209
E75-L*	24560	11000	7420	171	575 to 1540	852 to 2282
E75-D*	24560	11000	7420	171	1543 to 12673	2288 to 18788

* Note: For the dimensions of the different models, please refer to chapter 3 Product dimensions, p. 16ff
For the calculation of the allowed moments, please observe pages 41ff

Tab. 5

Characteristic data	Type	
	E55	E75
Standard belt tension [N]	220	800
Moment at no load [Nm]	0.3	1.3
Max. traversing speed [m/s]	3	5
Max. acceleration [m/s ²]	10	15
Repeat accuracy [mm]	0.1	0.1
Compact Rail guiding rail	TLV28 / ULV18	TLV43 / ULV28
Slider type	CS28 spec. / CPA 18	CS43 spec. / CPA 28
Moment of inertia I _y [cm ⁴]	34.6	127
Moment of inertia I _z [cm ⁴]	41.7	172
Pitch diameter of pulley [m]	0.04138	0.05093
Moment of inertia of each pulley [gmm ²]	45633	139969
Stroke per shaft revolution [mm]	130	160
Mass of slider [g]	635	1772
Weight with zero stroke [g]	3167	7544
Weight with 1 m stroke [g]	5055	10751
Belt length [m]	2 x stroke + 0.63	2 x stroke + 0.792
Mass of belt [g/m]	74	185

Tab. 6

Type ED

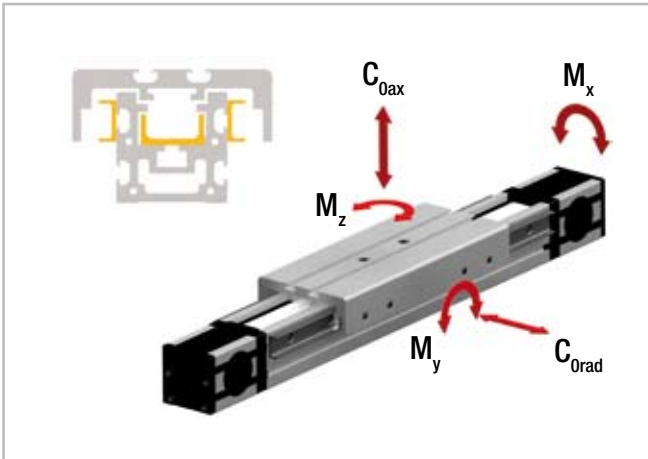

Fig. 11

Type	C [N]	C _{Orad} [N]	C _{Oax} [N]	M _x [Nm]	M _y [Nm]	M _z [Nm]
ED75	9815	5500	8700	400.2	868	209
ED75-L*	19630	11000	8700	400.2	1174 to 2305	852 to 2282
ED75-D*	19630	11000	17400	800.4	3619 to 24917	2288 to 15752

* Note: For the dimensions of the different models, please refer to chapter 3 Product dimensions, p. 16ff
For the calculation of the allowed moments, please observe pages 41ff

Tab. 7

	Type
Characteristic data	ED75
Standard belt tension [N]	1000
Moment at no load [Nm]	1.5
Max. traversing speed [m/s]	5
Max. acceleration [m/s ²]	15
Repeat accuracy [mm]	0.1
Compact Rail guiding rail	ULV43 / ULV28
Slider type	CS43 spec. / CS28 spec.
Moment of inertia I _y [cm ⁴]	127
Moment of inertia I _z [cm ⁴]	172
Pitch diameter of pulley [m]	0.05093
Moment of inertia of each pulley [gmm ²]	139969
Stroke per shaft revolution [mm]	160
Mass of slider [g]	3770
Weight with zero stroke [g]	9850
Weight with 1 m stroke [g]	14400
Belt length [m]	2 x stroke + 0.92
Mass of belt [g/m]	185

Tab. 8

Type H

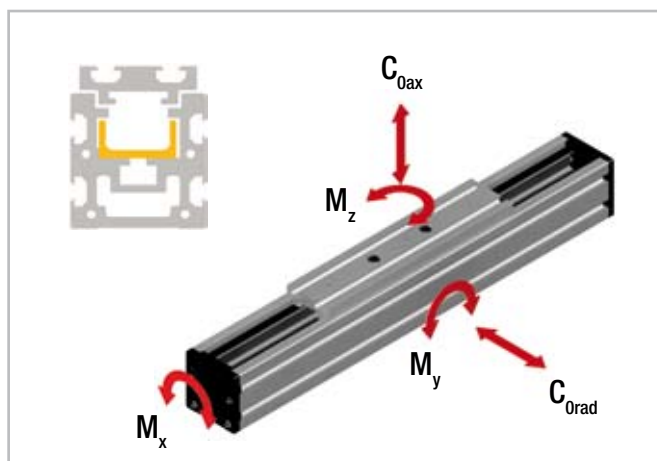

Fig. 12

Type	C [N]	C _{0rad} [N]	C _{0ax} [N]	M _x [Nm]	M _y [Nm]	M _z [Nm]
H40	1530	820	0	0	0	13.1
H40-L*	3060	1640				61 to 192
H40-D*	3060	1640				192 to 1558
H55	4260	2175				54.5
H55-L*	8520	4350				239 to 652
H55-D*	8520	4350				652 to 6677
H75	12280	5500				209
H75-L*	24560	11000				852 to 2282
H75-D*	24560	11000				2288 to 18788

* Note: For the dimensions of the different models, please refer to chapter 3 Product dimensions, p. 16ff
For the calculation of the allowed moments, please observe pages 41ff

Tab. 9

Characteristic data	Type		
	H40	H55	H75
Max. traversing speed [m/s]	3	5	7
Max. acceleration [m/s ²]	10	15	15
Repeat accuracy [mm]	0.1	0.1	0.1
Compact Rail guiding rail	ULV18	ULV28	ULV43
Slider type	CS18 spec.	CS28 spec.	CS43 spec.
Moment of inertia I _y [cm ⁴]	12	34.6	127
Moment of inertia I _z [cm ⁴]	13.6	41.7	172
Mass of slider [g]	220	475	1242
Weight with zero stroke [g]	860	1460	4160
Weight with 1 m stroke [g]	3383	4357	9381

Tab. 10

Product dimensions

Type A

A40 system

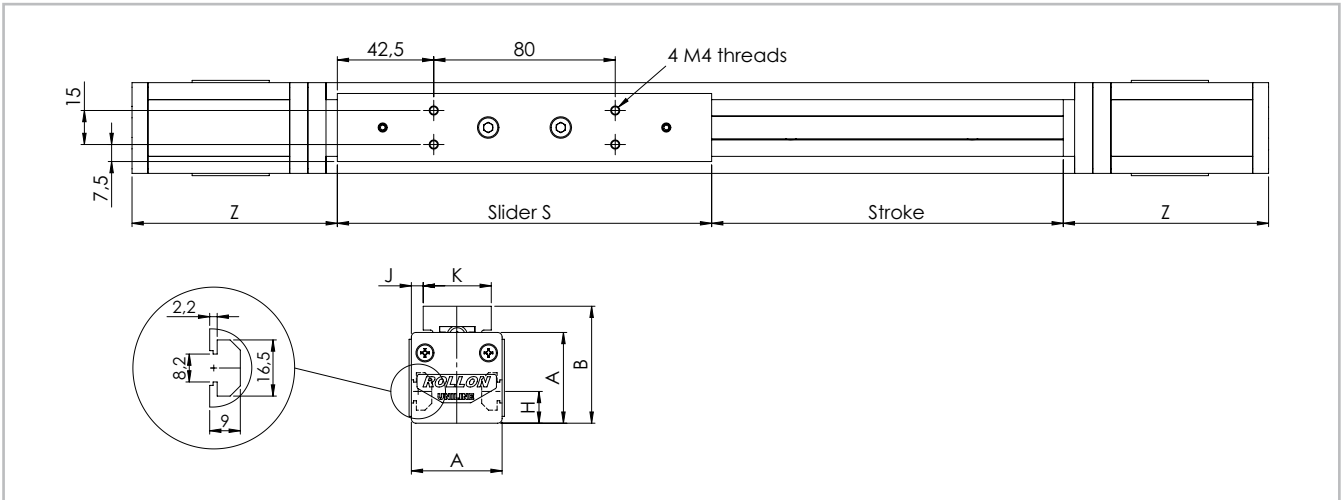

Fig. 13

Type	A [mm]	B [mm]	H [mm]	J [mm]	K [mm]	S [mm]	Z [mm]	Stroke* [mm]
A40	40	51.5	14	5	30	165	91.5	1900

* Maximum stroke for a single-piece guiding rail. For longer strokes, see p. 45, Tab. 48

Tab. 11

A40 motor connection

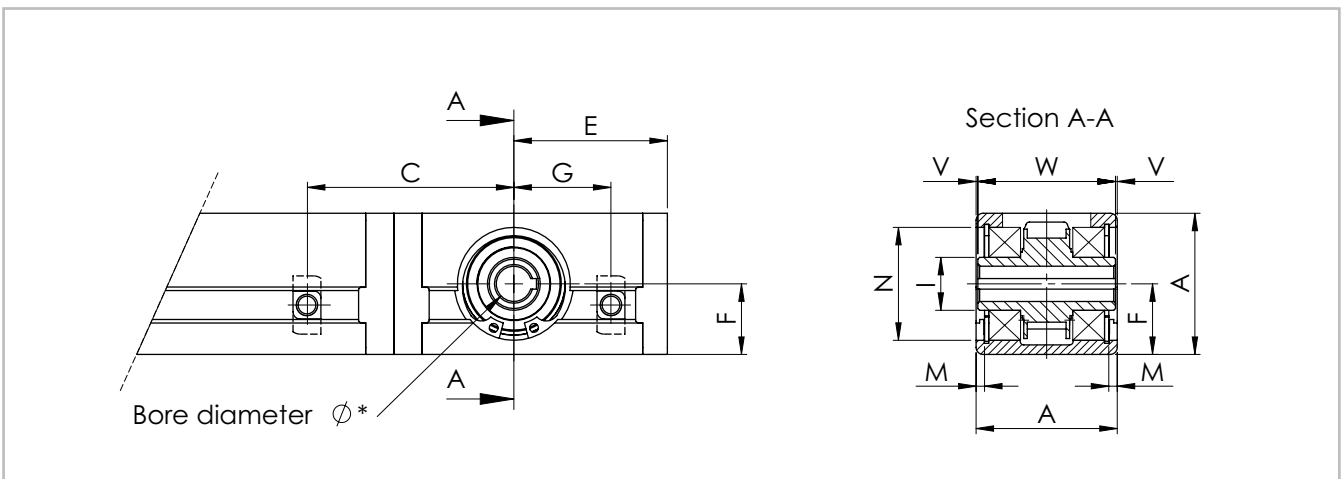

* For information on the motor connection bores, see ordering key

Abb. 14

Type	A [mm]	C* [mm]	E [mm]	F [mm]	G* [mm]	I [mm]	M [mm]	N [mm]	V [mm]	W [mm]
A40	40	57	43.5	20	26	Ø 14,9	2.3	Ø 32	0.5	39

* For the position of the T-nuts when using our motor adapter plates, see p. 34ff

Tab. 12

A55 – A75 system

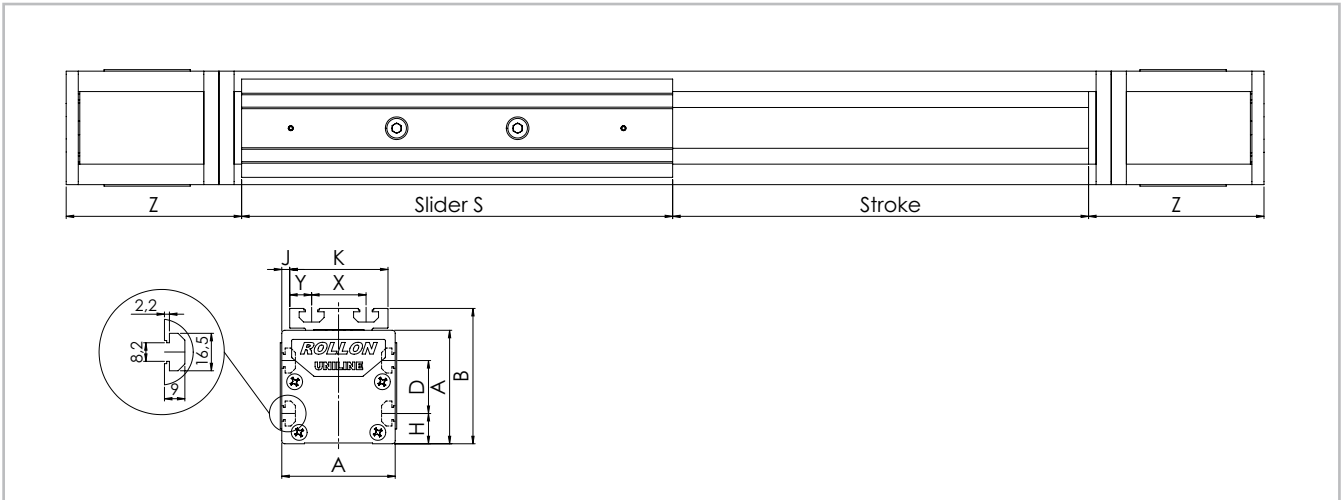

Fig. 15

Type	A [mm]	B [mm]	D [mm]	H [mm]	J [mm]	K [mm]	S [mm]	X [mm]	Y [mm]	Z [mm]	Stroke* [mm]
A55	55	71	25	15	1.5	52	200	28	12	108	3070
A75	75	90	35	20	5	65	285	36	14.5	116	3420

* Maximum stroke for a single-piece guiding rail. For longer strokes, see p. 45, Tab. 48

Tab. 13

A55 – A75 motor connection

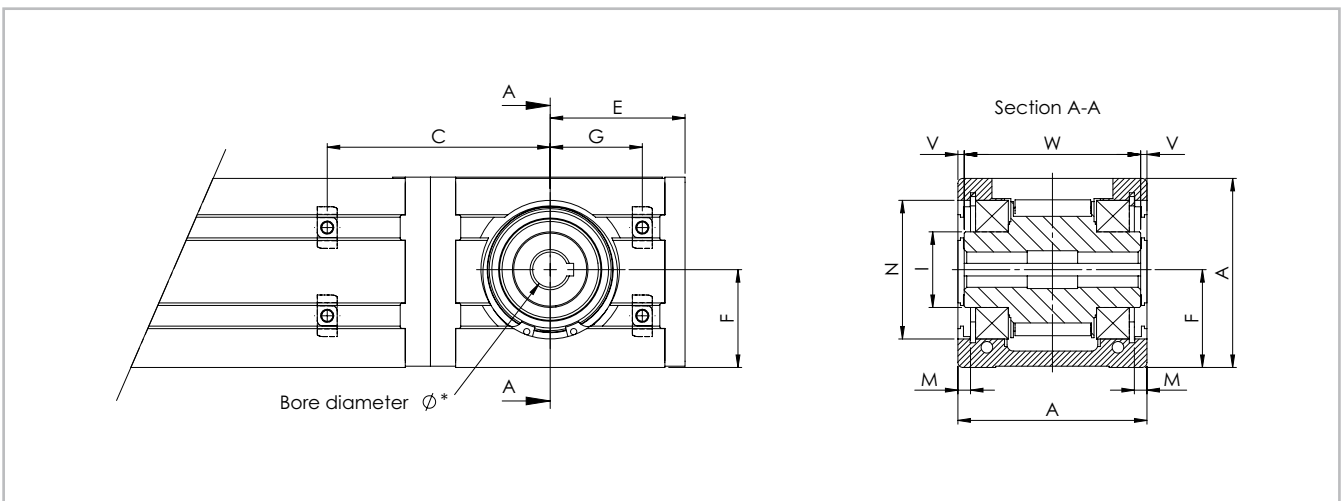

Fig. 16

* For information on the motor connection bores, see ordering key

Type	A [mm]	C* [mm]	E [mm]	F [mm]	G* [mm]	I [mm]	M [mm]	N [mm]	V [mm]	W [mm]
A55	55	67.5	50.5	27.5	32.5	Ø 24.9	2.35	Ø 47	0.5	54
A75	75	71.5	53.5	38.8	34.5	Ø 29.5	4.85	Ø 55	2.3	70.4

* For the position of the T-nuts when using our motor adapter plates, see p. 34ff

Tab. 14

A100 system

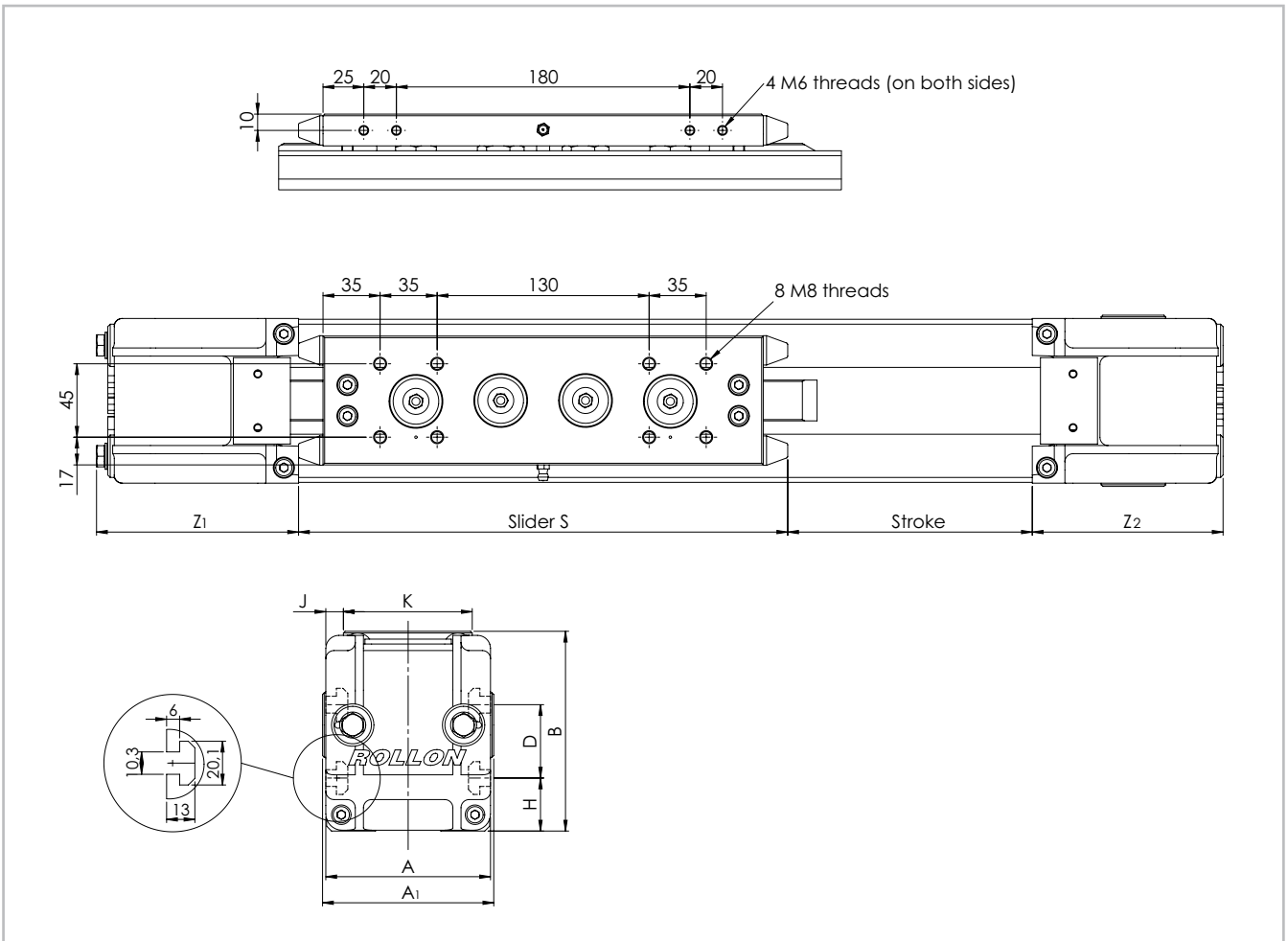

Fig. 17

Type	A [mm]	A ₁ [mm]	B [mm]	D [mm]	H [mm]	J [mm]	K [mm]	S [mm]	Z ₁ [mm]	Z ₂ [mm]	Stroke* [mm]
A100	101	105	122.5	45	32.5	10.5	79	300	123	117	3420

* Maximum stroke for a single-piece guiding rail. For longer strokes, see p. 45, tab. 48

Tab. 15

A100 motor connection – model A

Motor connection via key

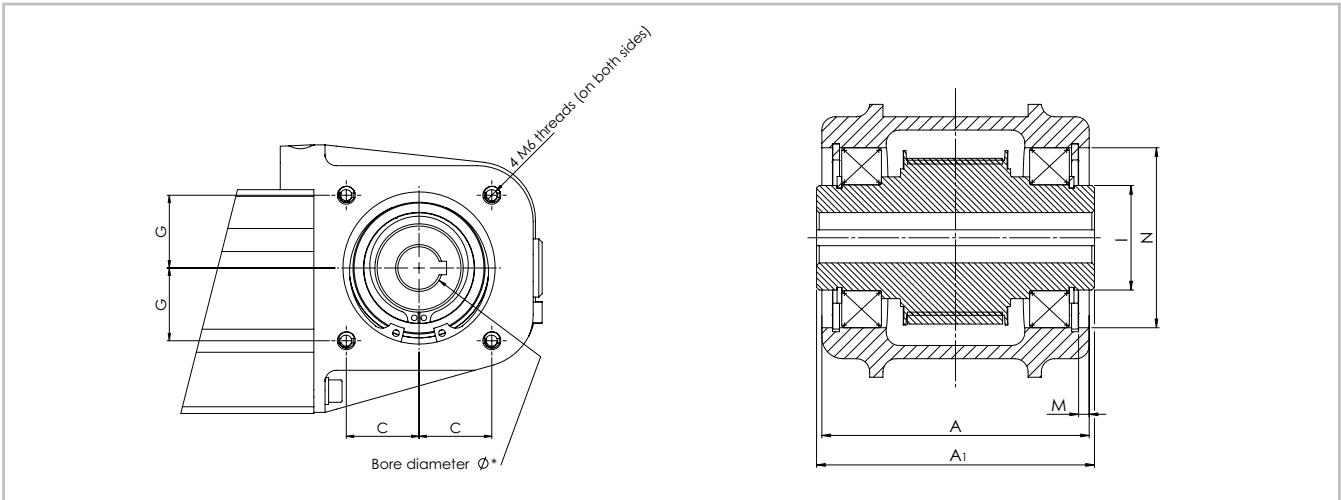

Fig. 18

* For information on the motor connection bores, see ordering key

** For information on the motor drive shaft, see chapter Accessories, p. 38, fig. 47

Type	A [mm]	A ₁ [mm]	C [mm]	G [mm]	I [mm]	M [mm]	N [mm]
A100	101	105	32.5	32.5	Ø 39,5	4	Ø 68

Tab. 16

A100 motor connection – model B

Motor connection by means of conical fitting device

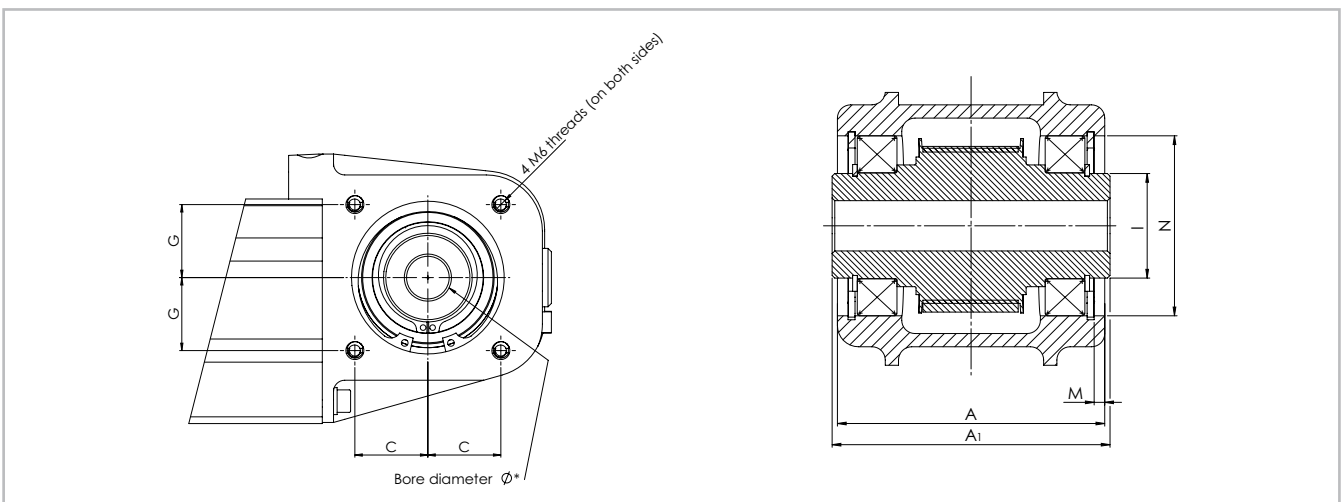

Fig. 19

* See chapter Accessories, p. 39, fig. 48

Type	A [mm]	A ₁ [mm]	C [mm]	G [mm]	I [mm]	M [mm]	N [mm]
A100	101	105	32.5	32.5	Ø 39,5	4	Ø 68

Tab. 17

Type A version L with long slider

A40L system

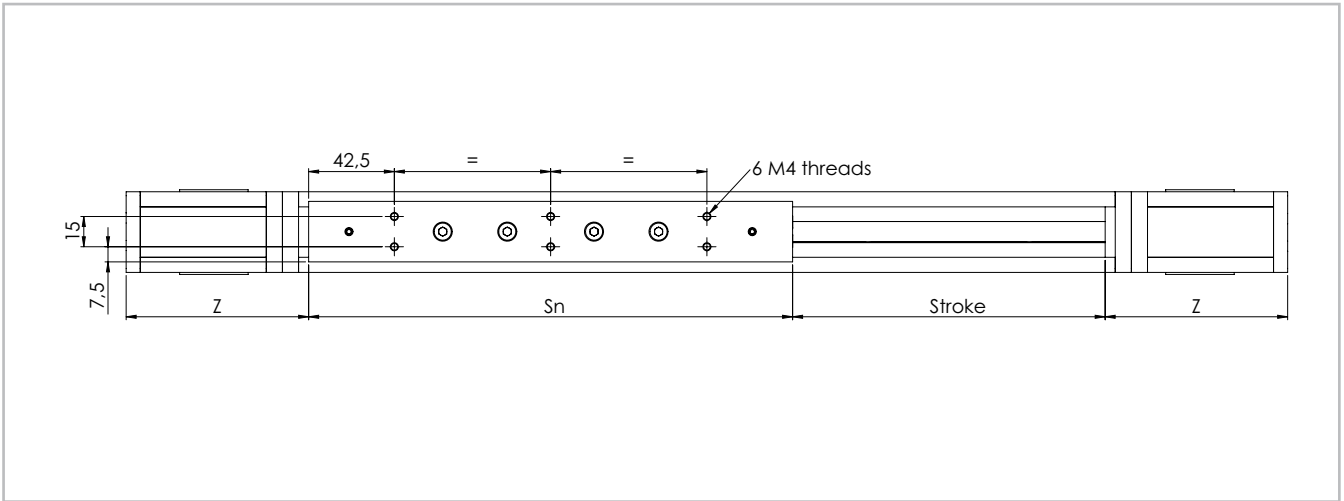

Fig. 20

Type	S_{min} [mm]	S_{max} [mm]	S_n [mm]	Z [mm]	Stroke* [mm]
A40L	240	400	$S_n = S_{min} + n \cdot 10$	91.5	1660

* Maximum stroke for a single-piece guiding rail and a maximum slider plate length S_{max} .
For longer strokes, see p. 45, tab. 48

Tab. 18

A55L – A75L system

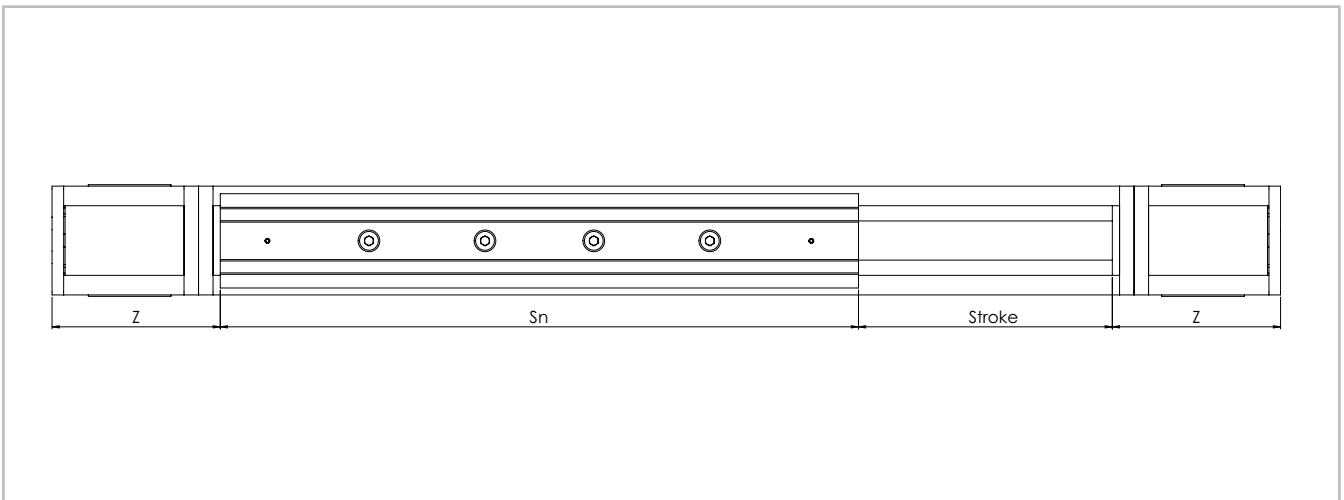

Fig. 21

Type	S_{min} [mm]	S_{max} [mm]	S_n [mm]	Z [mm]	Stroke* [mm]
A055-L	310	500	$S_n = S_{min} + n \cdot 10$	108	2770
A075-L	440	700	$S_n = S_{min} + n \cdot 10$	116	3000

* Maximum stroke for a single-piece guiding rail and a maximum slider plate length S_{max} .
For longer strokes, see p. 45, tab. 48

Tab. 19

A100L system

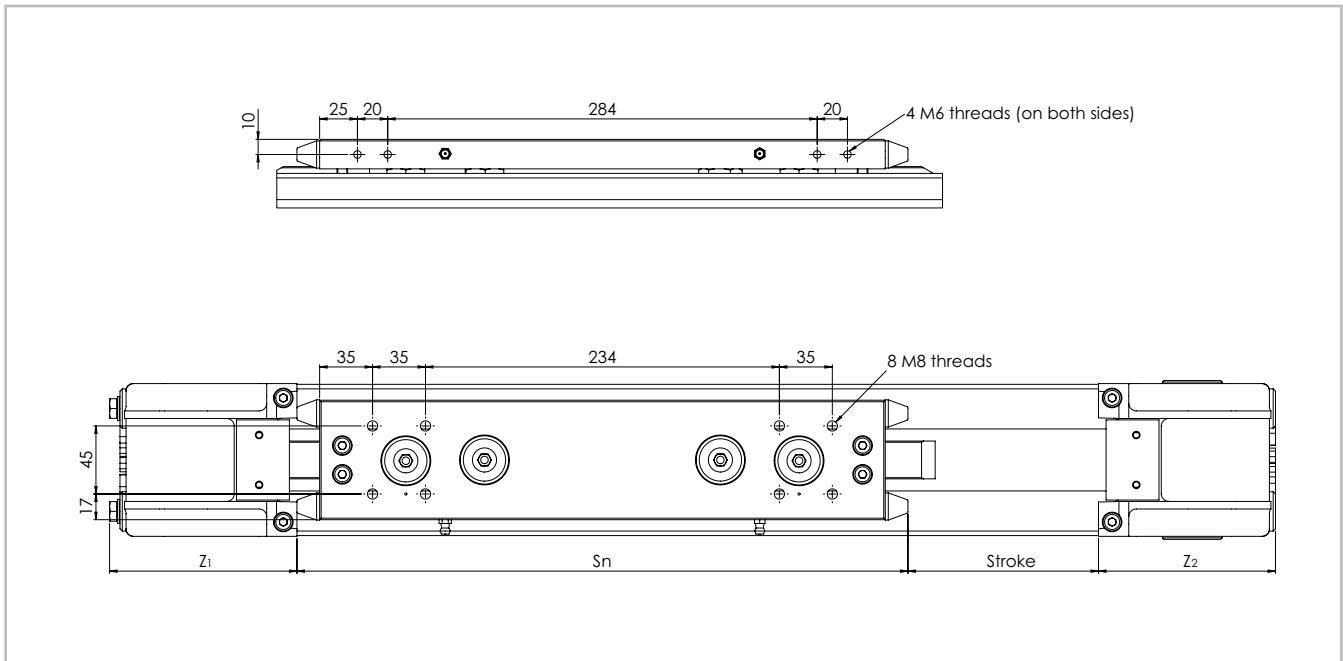

Fig. 22

Type	S _{min} [mm]	S _{max} [mm]	Sn [mm]	Z ₁ [mm]	Z ₂ [mm]	Stroke* [mm]
A100L	404	404	Sn = S _{min} = S _{max}	123	117	3316

* Maximum stroke for a single-piece guiding rail and a maximum slider plate length S_{max}
 For longer strokes, see p. 45, tab. 48

Tab. 20

Type A version D with double slider

A40D system

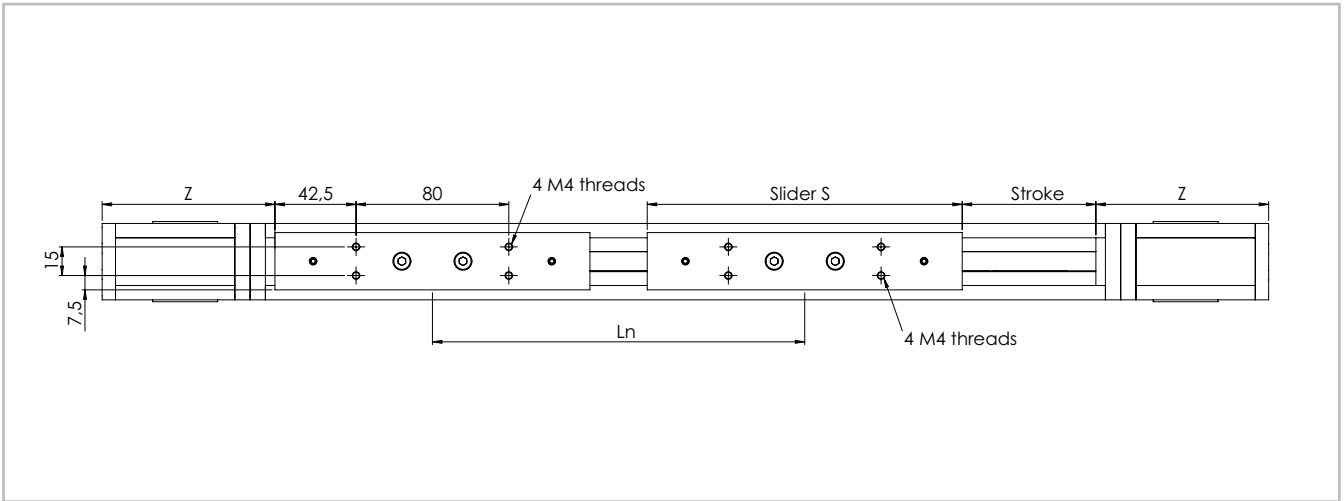

Fig. 23

Type	S [mm]	L _{min} [mm]	L _{max} ** [mm]	Ln [mm]	Z [mm]	Stroke* [mm]
A40D	165	235	1900	$L_n = L_{min} + n \cdot 5$	91.5	1660

Tab. 21

* Maximum stroke for a single-piece guiding rail and a minimum slider plate distance L_{min}
 ** Maximum distance L_{max} between the centres of slider plates at a stroke of 0 mm
 For longer strokes, see p. 45, tab. 48

A55D – A75D system

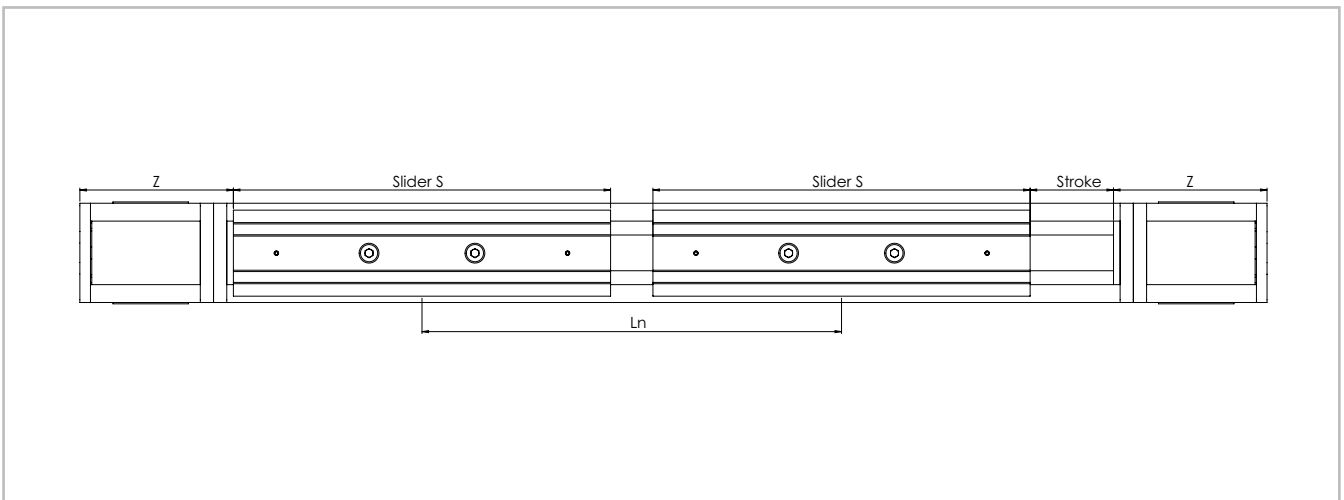

Fig. 24

Type	S [mm]	L _{min} [mm]	L _{max} ** [mm]	Ln [mm]	Z [mm]	Stroke* [mm]
A55D	200	300	3070	$L_n = L_{min} + n \cdot 5$	108	2770
A75D	285	416	3416	$L_n = L_{min} + n \cdot 8$	116	3000

Tab. 22

* Maximum stroke for a single-piece guiding rail and a minimum slider plate distance L_{min}
 ** Maximum distance L_{max} between the centres of slider plates at a stroke of 0 mm
 For longer strokes, see p. 45, tab. 48

A100D system

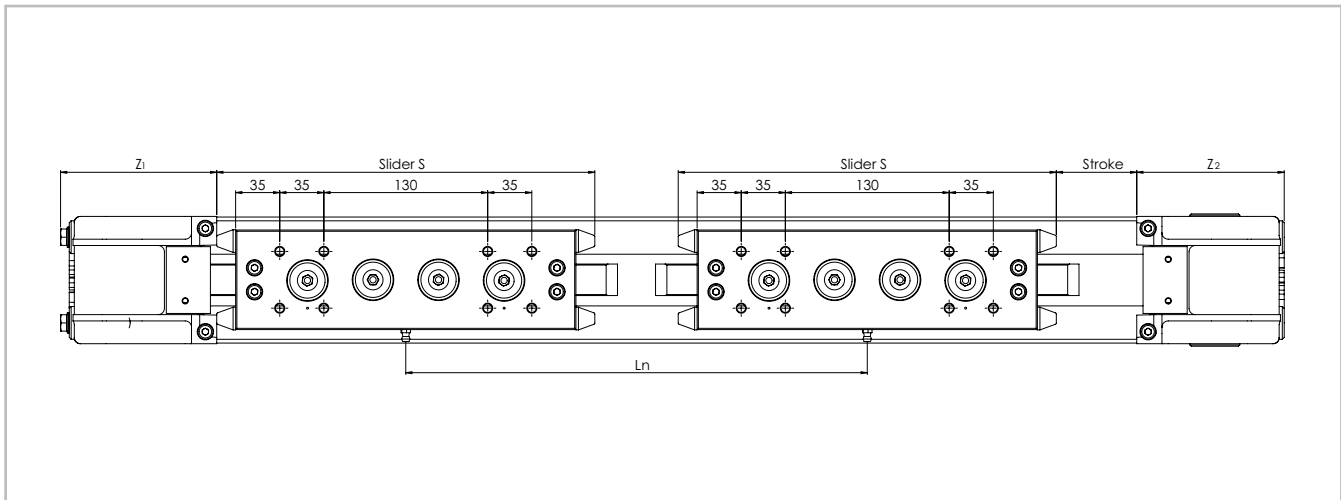

Fig. 25

Type	S [mm]	L_{min} [mm]	L_{max}^{**} [mm]	L_n [mm]	Z_1 [mm]	Z_2 [mm]	Stroke* [mm]
A100D	300	396	3396	$L_n = L_{min} + n \cdot 50$	123	117	3024

* Maximum stroke for a single-piece guiding rail and a minimum slider plate distance L_{min}
 ** Maximum distance L_{max} between the centres of slider plates at a stroke of 0 mm
 For longer strokes, see p. 45, tab. 48

Tab. 23

Type C

C55 – C75 system

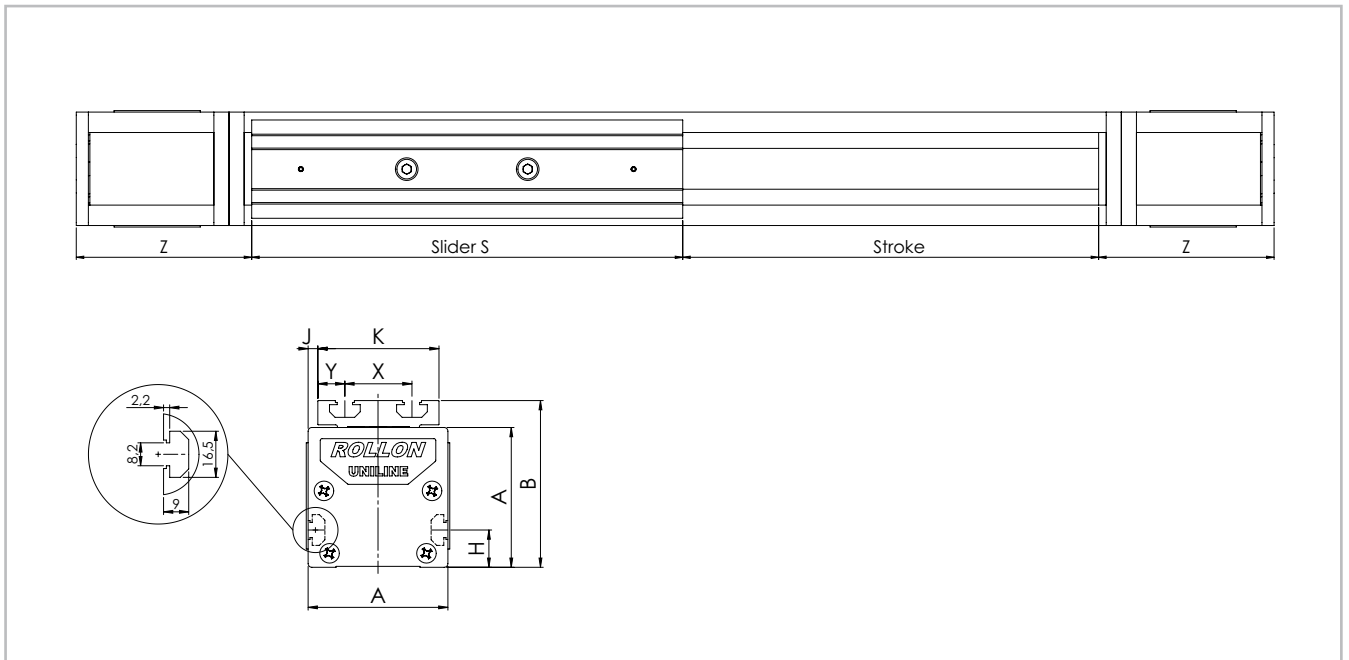

Fig. 26

Type	A [mm]	B [mm]	H [mm]	J [mm]	K [mm]	S [mm]	X [mm]	Y [mm]	Z [mm]	Stroke* [mm]
C55	55	71	15	1.5	52	200	28	12	108	1850
C75	75	90	20	5	65	285	36	14.5	116	3000

* Maximum stroke for a single-piece guiding rail. For longer strokes, see p. 45, tab. 48

Tab. 24

C55 – C75 motor connection

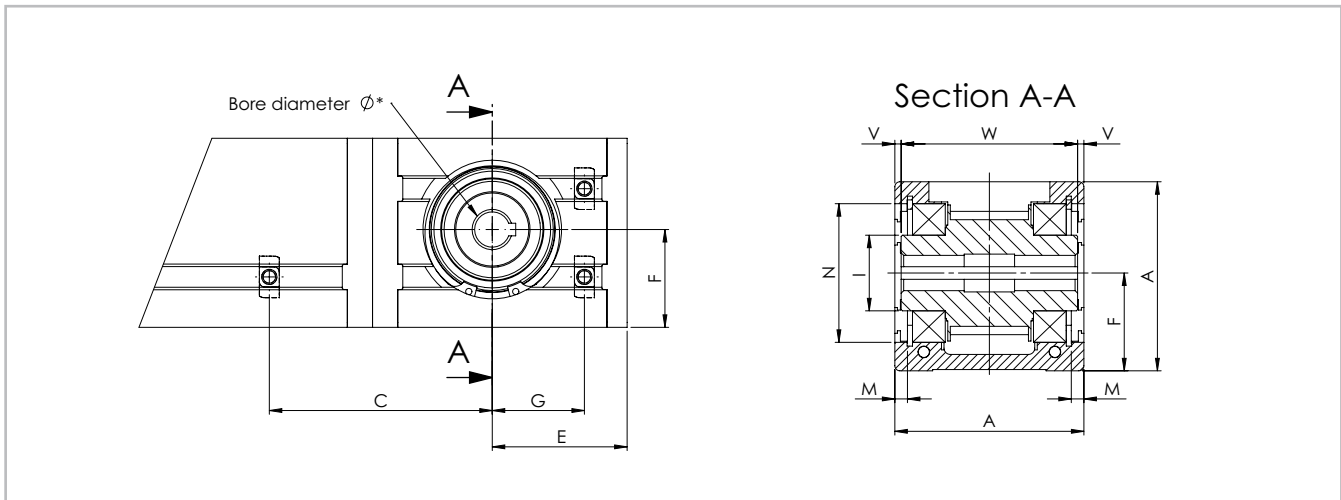

* For information on the motor connection bores, see ordering key

Fig. 27

Type	A [mm]	C* [mm]	E [mm]	F [mm]	G* [mm]	I [mm]	M [mm]	N [mm]	V [mm]	W [mm]
C55	55	67.5	50.5	27.5	32.5	\varnothing 24.9	2.35	\varnothing 47	0.5	54
C75	75	71.5	53.5	38.8	34.5	\varnothing 29,5	4.85	\varnothing 55	2.3	70.4

* For the position of the T-nuts when using our motor adapter plates, see p. 34ff

Tab. 25

Type C version L with long slider

C55L – C75L system

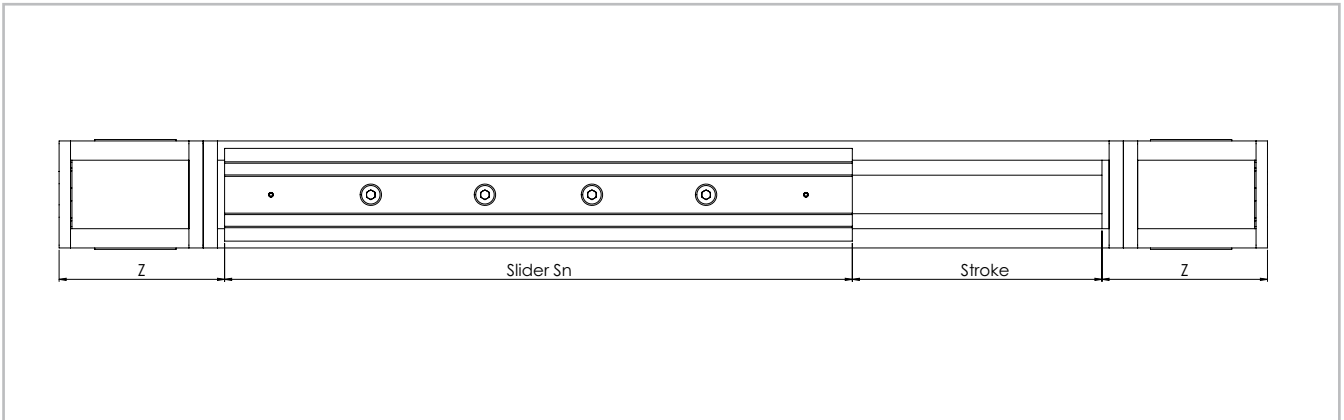

Fig. 28

Type	S _{min} [mm]	S _{max} [mm]	S _n [mm]	Z [mm]	Stroke* [mm]
C55L	310	500	$S_n = S_{min} + n \cdot 10$	108	1550
C75L	440	700	$S_n = S_{min} + n \cdot 10$	116	2610

* Maximum stroke for a single-piece guiding rail and a maximum slider plate length S_{max}.
For longer strokes, see p. 45, tab. 48

Tab. 26

Type C version D with double slider

C55D – C75D system

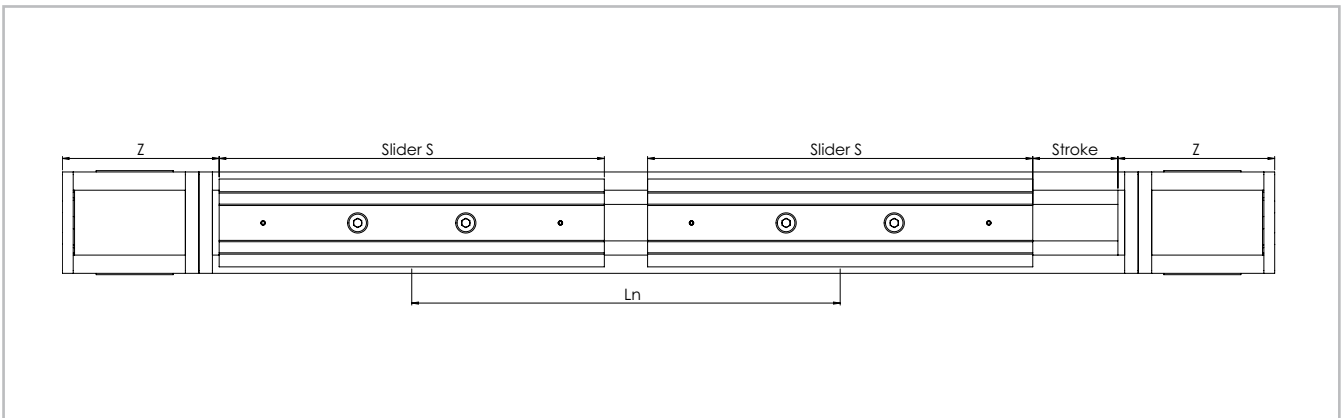

Fig. 29

Type	S [mm]	L _{min} [mm]	L _{max} ** [mm]	L _n [mm]	Z [mm]	Stroke* [mm]
C55D	200	300	1850	$L_n = L_{min} + n \cdot 5$	108	1570
C75D	285	416	3024	$L_n = L_{min} + n \cdot 8$	116	2610

* Maximum stroke for a single-piece guiding rail and a minimum slider plate distance L_{min}.
** Maximum distance L_{max} between the centres of slider plates at a stroke of 0 mm
For longer strokes, see p. 45, tab. 48

Tab. 27

Type E

E75 system

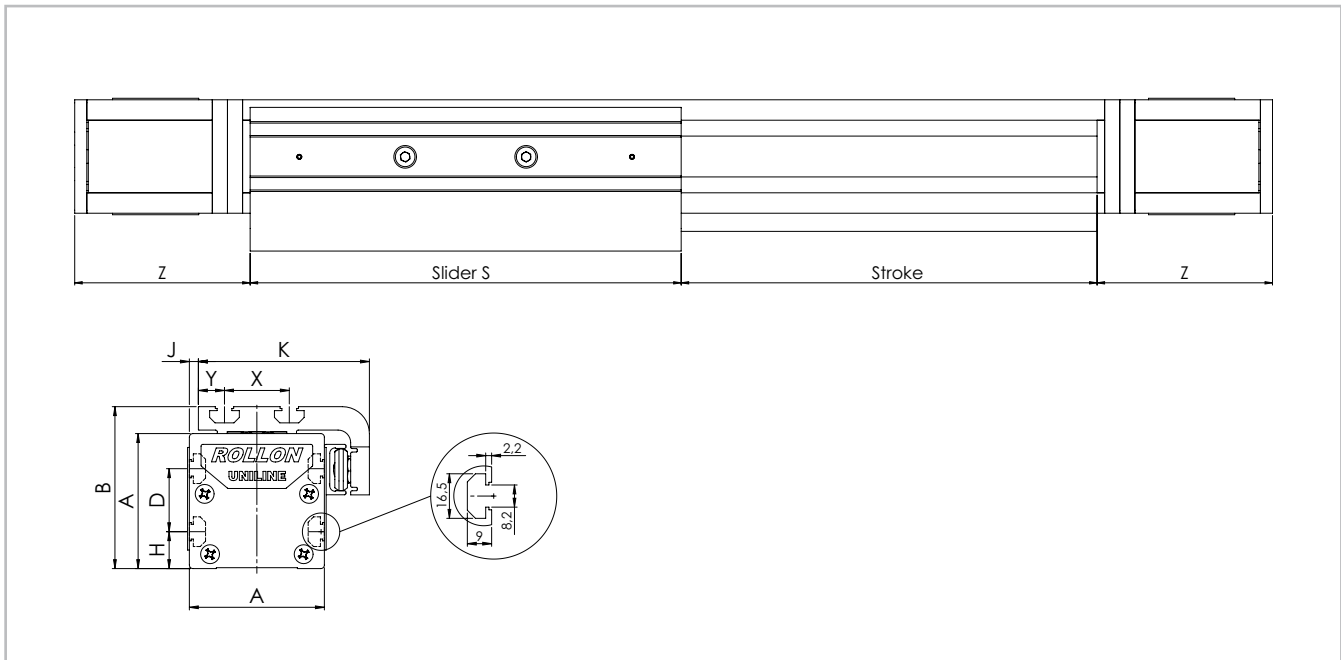

Fig. 30

Type	A [mm]	B [mm]	D [mm]	H [mm]	J [mm]	K [mm]	S [mm]	X [mm]	Y [mm]	Z [mm]	Stroke* [mm]
E55	55	71	25	15	1.5	71	200	28	12	108	3070
E75	75	90	35	20	5	95	285	36	14.5	116	3420

* Maximum stroke for a single-piece guiding rail. For longer strokes, see p. 45, tab. 48

Tab. 28

E55 – E75 motor connection

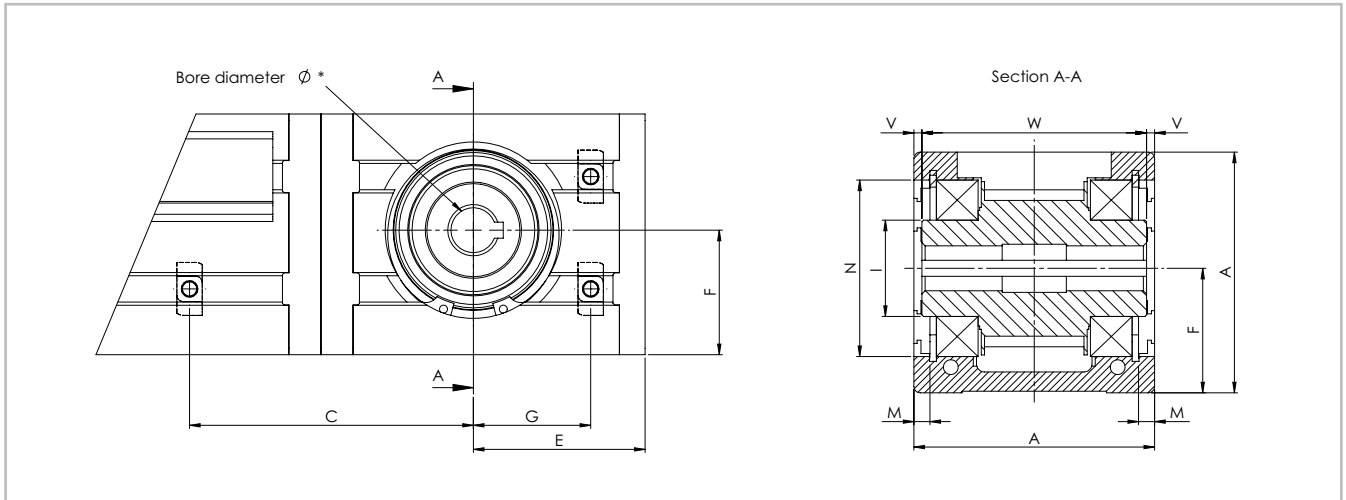

* For information on the motor connection bores, see ordering key

Fig. 31

Type	A [mm]	C* [mm]	E [mm]	F [mm]	G* [mm]	I [mm]	M [mm]	N [mm]	V [mm]	W [mm]
E55	55	67.5	50.5	27.5	32.5	Ø 24.9	2.35	Ø 47	0.5	54
E75	75	71.5	53.5	38.8	34.5	Ø 29.5	4.85	Ø 55	2.3	70.4

* For the position of the T-nuts when using our motor adapter plates, see p. 34ff

Tab. 29

Type E version L with long slider

E55L – E75L system

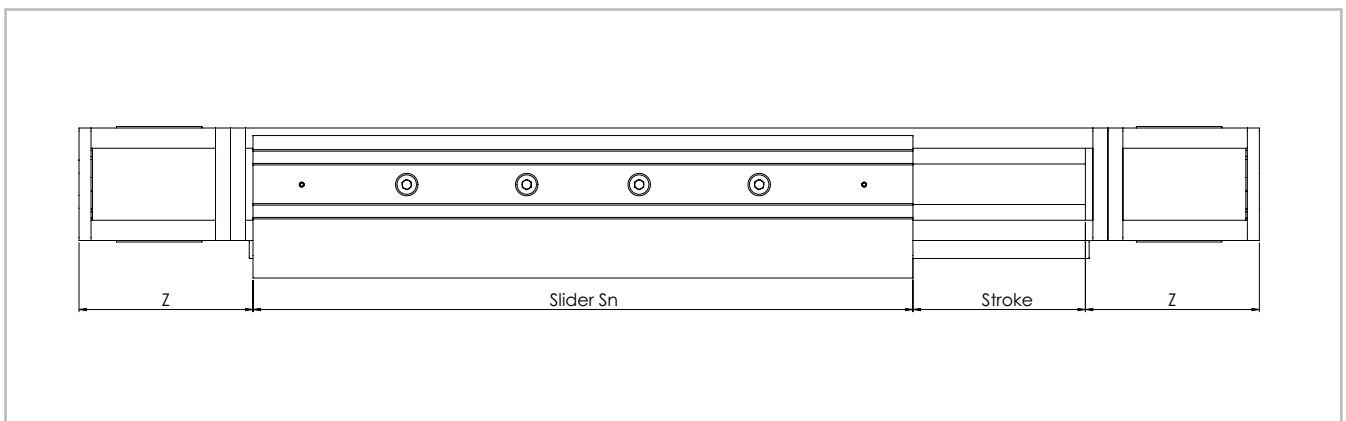

Fig. 32

Type	S _{min} [mm]	S _{max} [mm]	Sn [mm]	Z [mm]	Stroke* [mm]
E55L	310	500	$S_n = S_{min} + n \cdot 10$	108	2770
E75L	440	700	$S_n = S_{min} + n \cdot 10$	116	3000

* Maximum stroke for a single-piece guiding rail and a maximum slider plate length S_{max}. For longer strokes, see p. 45, tab. 48

Tab. 30

Type E version D with double slider

E55D – E75D system

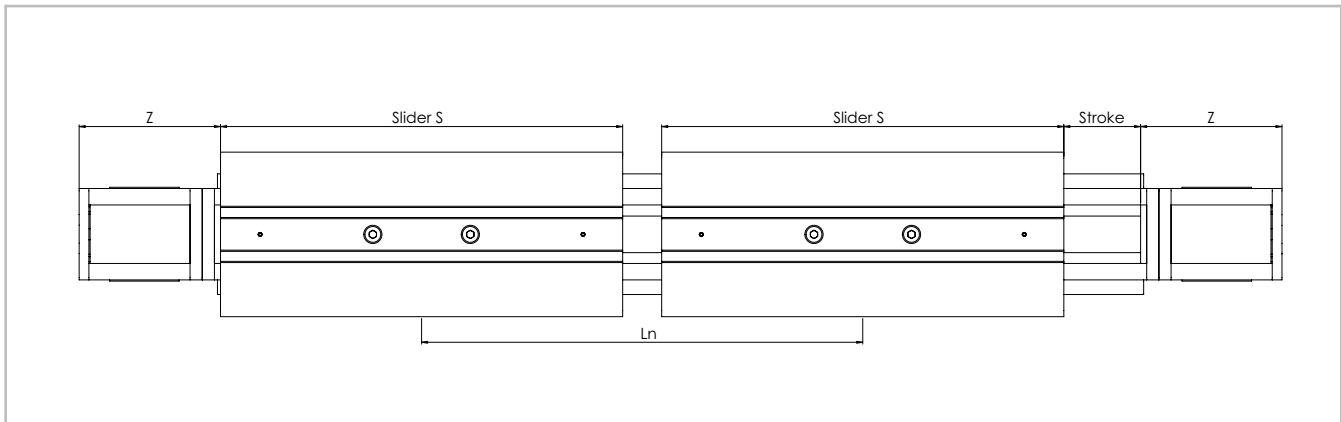

Fig. 33

Type	S [mm]	L_{\min} [mm]	L_{\max}^{**} [mm]	L_n [mm]	Z [mm]	Stroke* [mm]
E55D	200	300	3070	$L_n = L_{\min} + n \cdot 5$	108	2770
E75D	285	416	3416	$L_n = L_{\min} + n \cdot 8$	116	3000

* Maximum stroke for a single-piece guiding rail and a minimum slider plate distance L_{\min}
 ** Maximum distance L_{\max} between the centres of slider plates at a stroke of 0 mm
 For longer strokes, see p. 45, tab. 48

Tab. 31

Type ED

ED75 system

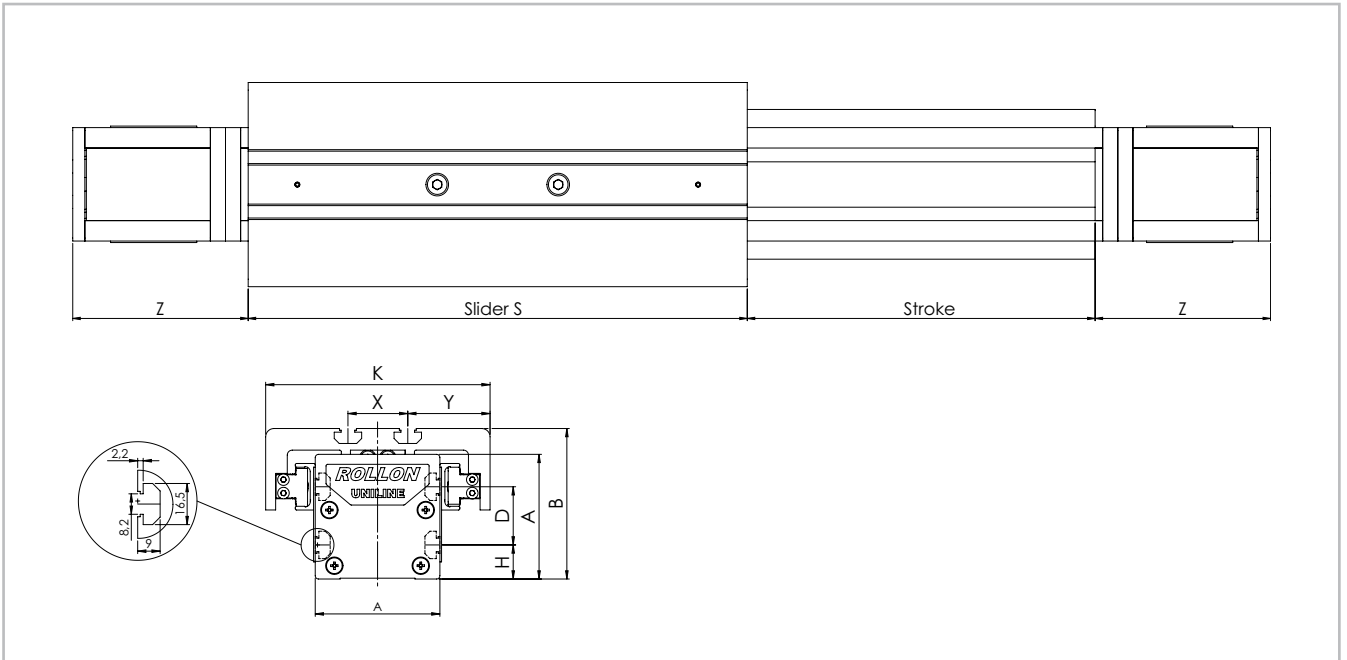

Fig. 34

Type	A [mm]	B [mm]	D [mm]	H [mm]	K [mm]	S [mm]	X [mm]	Y [mm]	Z [mm]	Stroke* [mm]
ED75	75	90	35	20	135	330	36	49.5	116	2900

* Maximum stroke for a single-piece guiding rail. For longer strokes, see p. 45, tab. 48

Tab. 32

ED75 motor connection

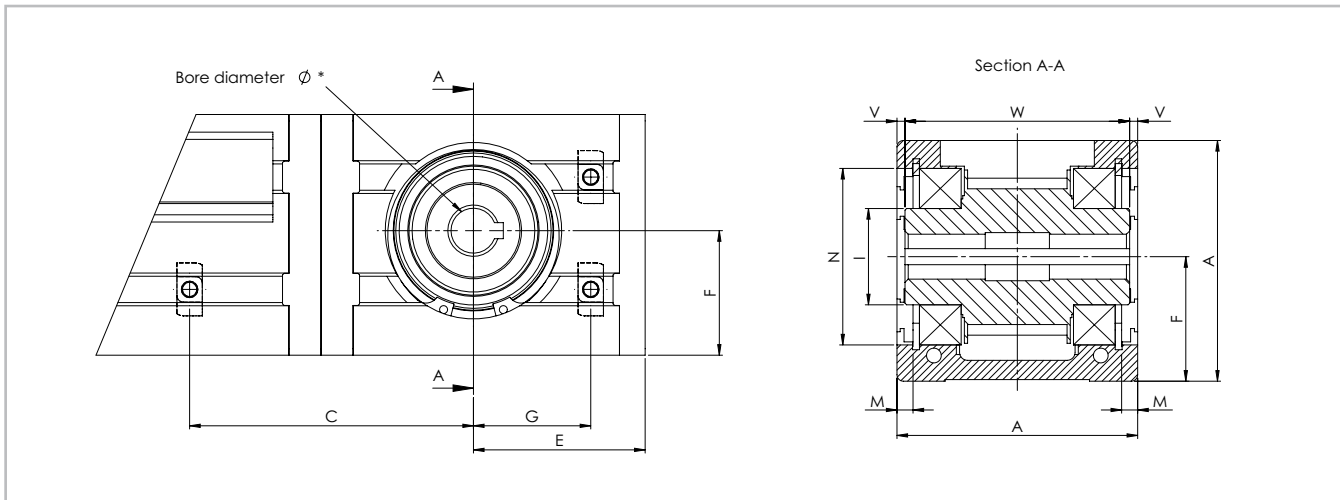

* For information on the motor connection bores, see ordering key

Fig. 35

Type	A [mm]	C* [mm]	E [mm]	F [mm]	G* [mm]	I [mm]	M [mm]	N [mm]	V [mm]	W [mm]
E75	75	71.5	53.5	38.8	34.5	∅ 29.5	4.85	∅ 55	2.3	70.4

* For the position of the T-nuts when using our motor adapter plates, see p. 34ff

Tab. 33

Type ED version L with long slider

ED75L system

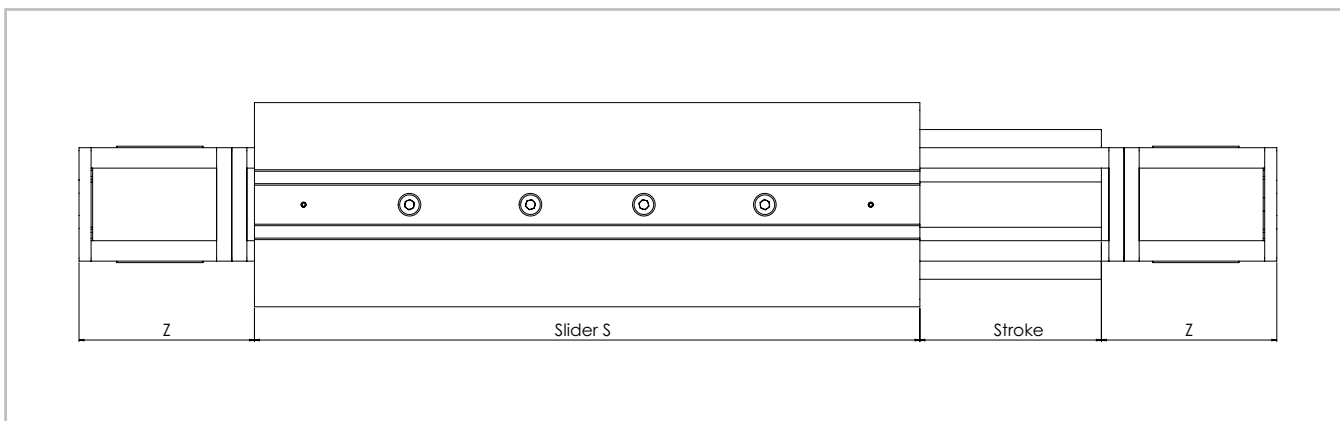

Fig. 36

Type	S _{min} * [mm]	S _{max} [mm]	S _n [mm]	Z [mm]	Stroke** [mm]
ED75L	440	700	$S_n = S_{min} + n \cdot 10$	116	2500

* The length of 440 mm is considered standard, all other lengths are considered special dimensions

** Maximum stroke for a single-piece guiding rail and a maximum slider plate length S_{max}. For longer strokes, see p. 45, tab. 48

Tab. 34

Type ED version D with double slider

ED75D system

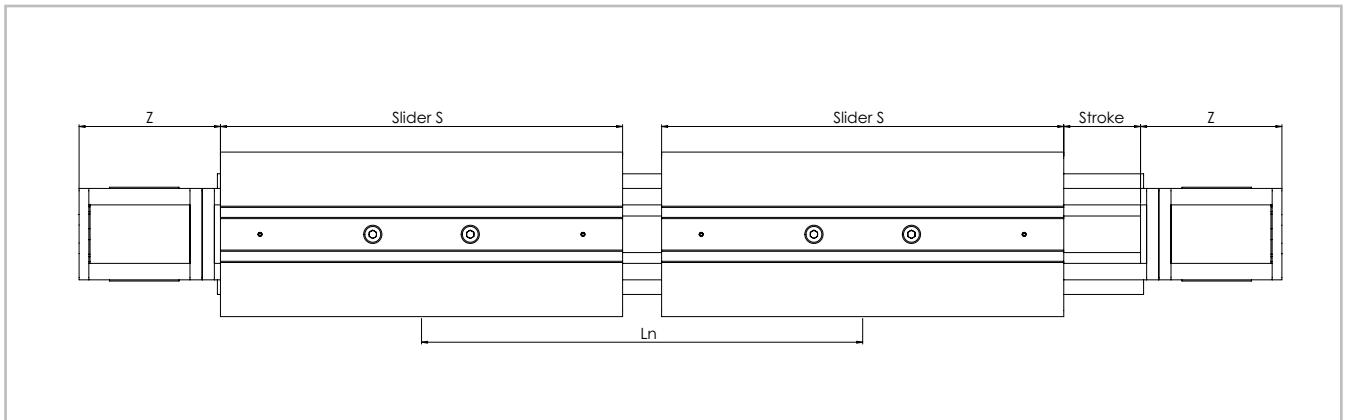

Fig. 37

Type	S [mm]	L_{\min} [mm]	L_{\max}^{**} [mm]	L_n [mm]	Z [mm]	Stroke* [mm]
ED75D	330	416	2864	$L_n = L_{\min} + n \cdot 8$	116	2450

* Maximum stroke for a single-piece guiding rail and a minimum slider plate distance L_{\min}
 ** Maximum distance L_{\max} between centres at a stroke of 0 mm
 For longer strokes, see p. 45, tab. 48

Tab. 35

Type H

H40 system

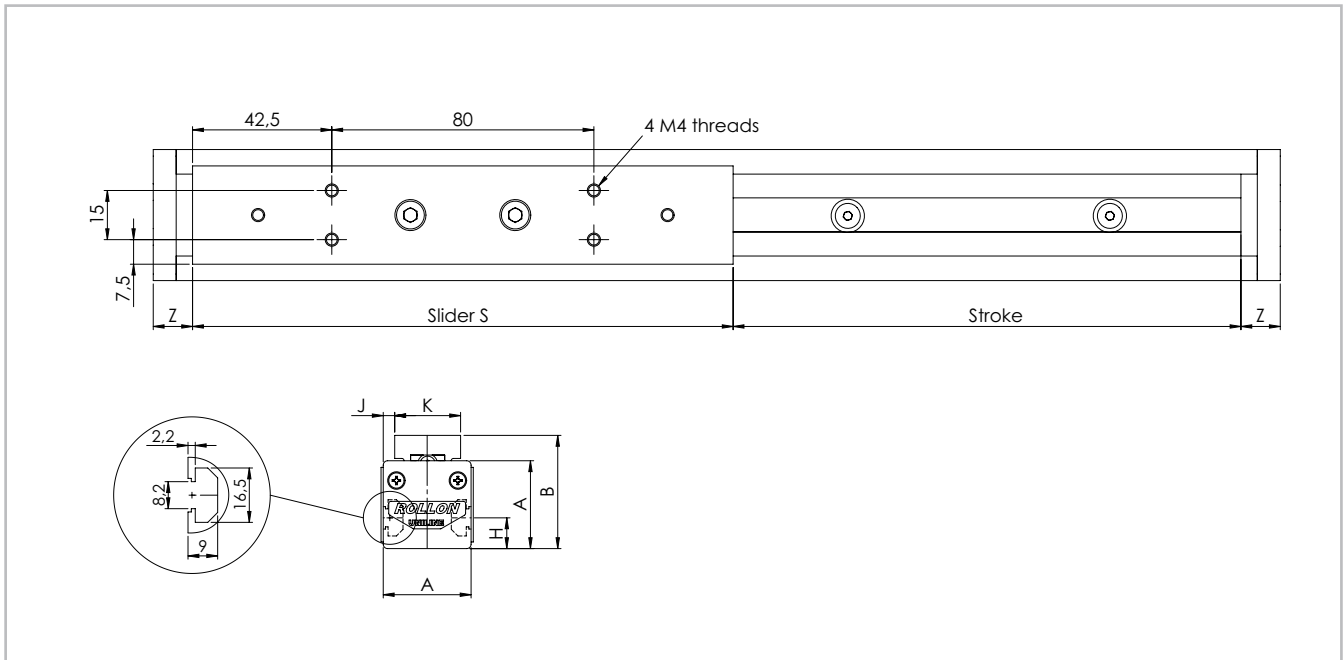

Fig. 38

H55 – 75 system

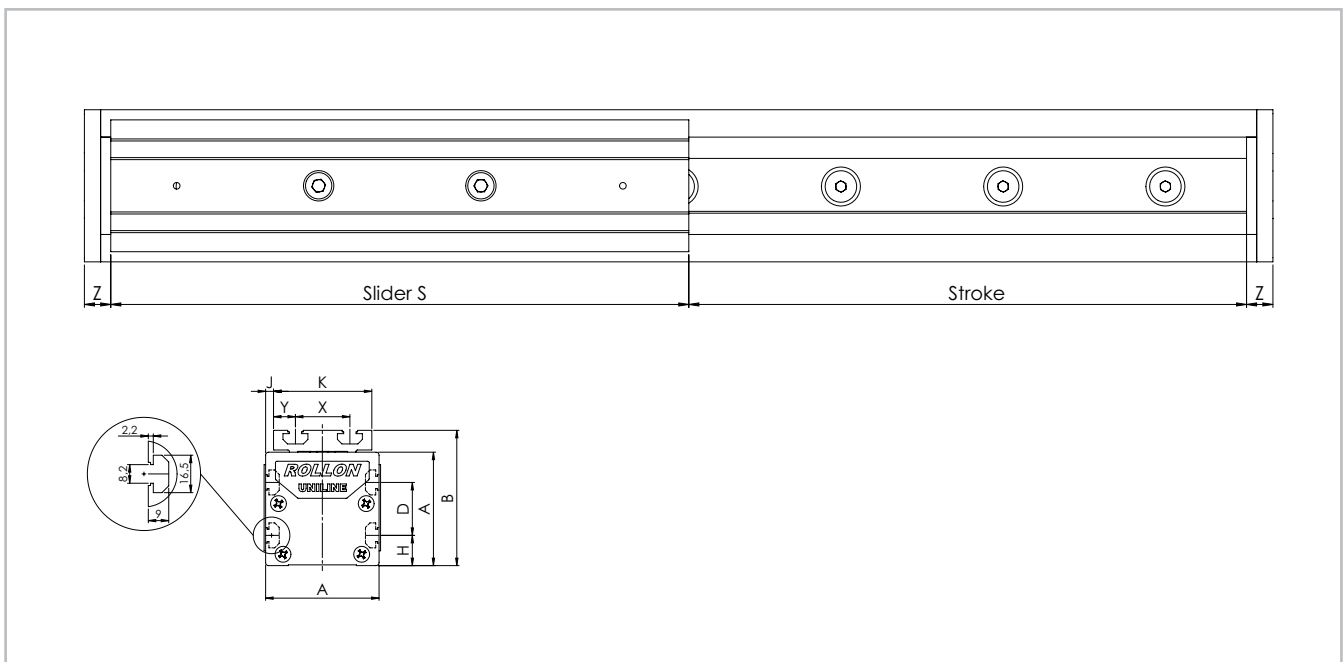

Fig. 39

Type*	A [mm]	B _{nom} [mm]	B _{min} [mm]	B _{max} [mm]	D [mm]	H [mm]	J [mm]	K [mm]	S [mm]	X [mm]	Y [mm]	Z [mm]	Stroke** [mm]
H40	40	51.5	51.2	52.6	-	14	5	30	165	-	-	12	1900
H55	55	71	70.4	72.3	25	15	1.5	52	200	28	12	13	3070
H75	75	90	88.6	92.5	35	20	5	65	285	36	14.5	13	3420

* Including long or double slider. See chapter 3 Product dimensions Types A...L and A...D, p. 20ff

** Maximum stroke for a single-piece guiding rail. For longer strokes, see p. 45, tab. 48

Tab. 36

Accessories

Adapter plates

Standard motor adapter plates AC2

Mounting plates for the most common motors or gearboxes. The connection bores for the motors or gearboxes must be made on site. All plates are delivered with M6 x 10 screws to DIN 912 and T-nuts for mounting on the linear units.

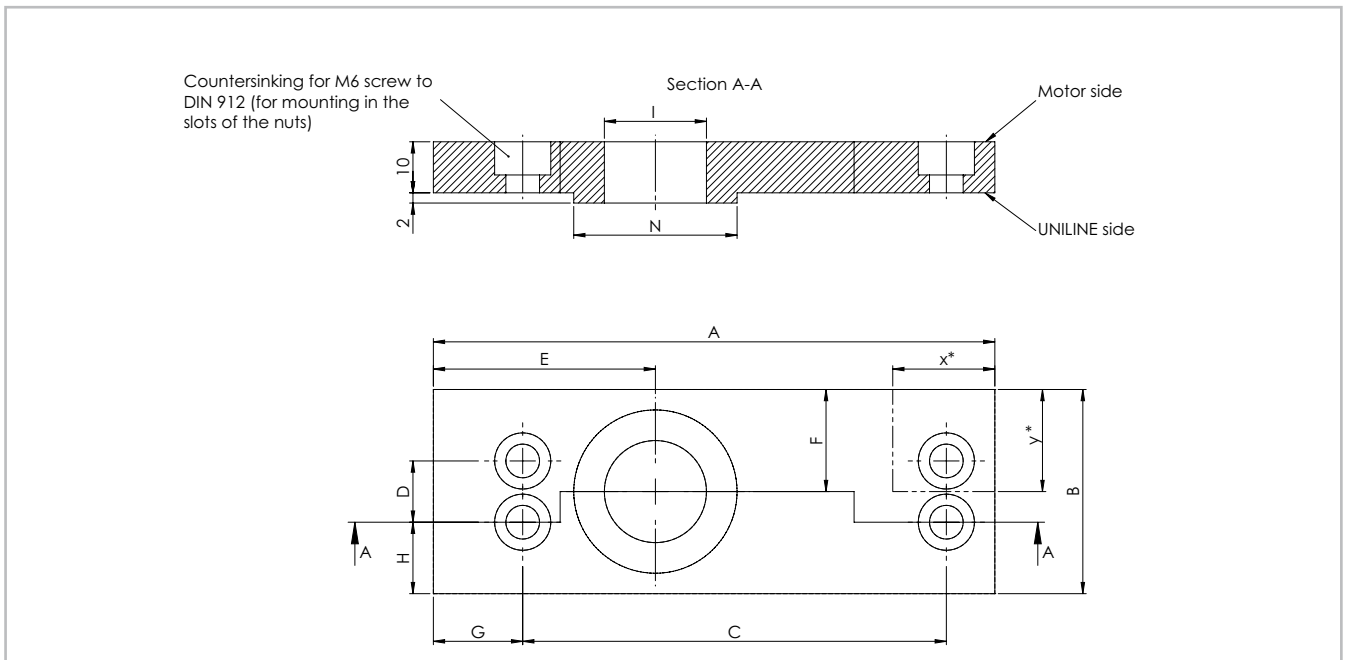

* The adapter plate must be provided with a recess in the X-Y area when using an ED75 linear unit.
X = 20 mm; Y = 35 mm

Fig. 40

Size	A [mm]	B [mm]	C [mm]	D [mm]	E [mm]	F [mm]	G [mm]	H [mm]	I [mm]	N [mm]
40	110	40	83	12	43.5	20	17.5	14	∅ 20	∅ 32
55	126	55	100	25	50.5	27.5	18	15	∅ 30	∅ 47
75	135	70	106	35	53.5	35	19	17.5	∅ 35	∅ 55

Tab. 37

NEMA plates AC1-P

Mounting plates for the most common motors or gearboxes to NEMA. These plates are delivered ready-to-mount on the linear axes. All plates are delivered with M6 x 10 screws to DIN 912 and T-nuts for mounting on the linear units.

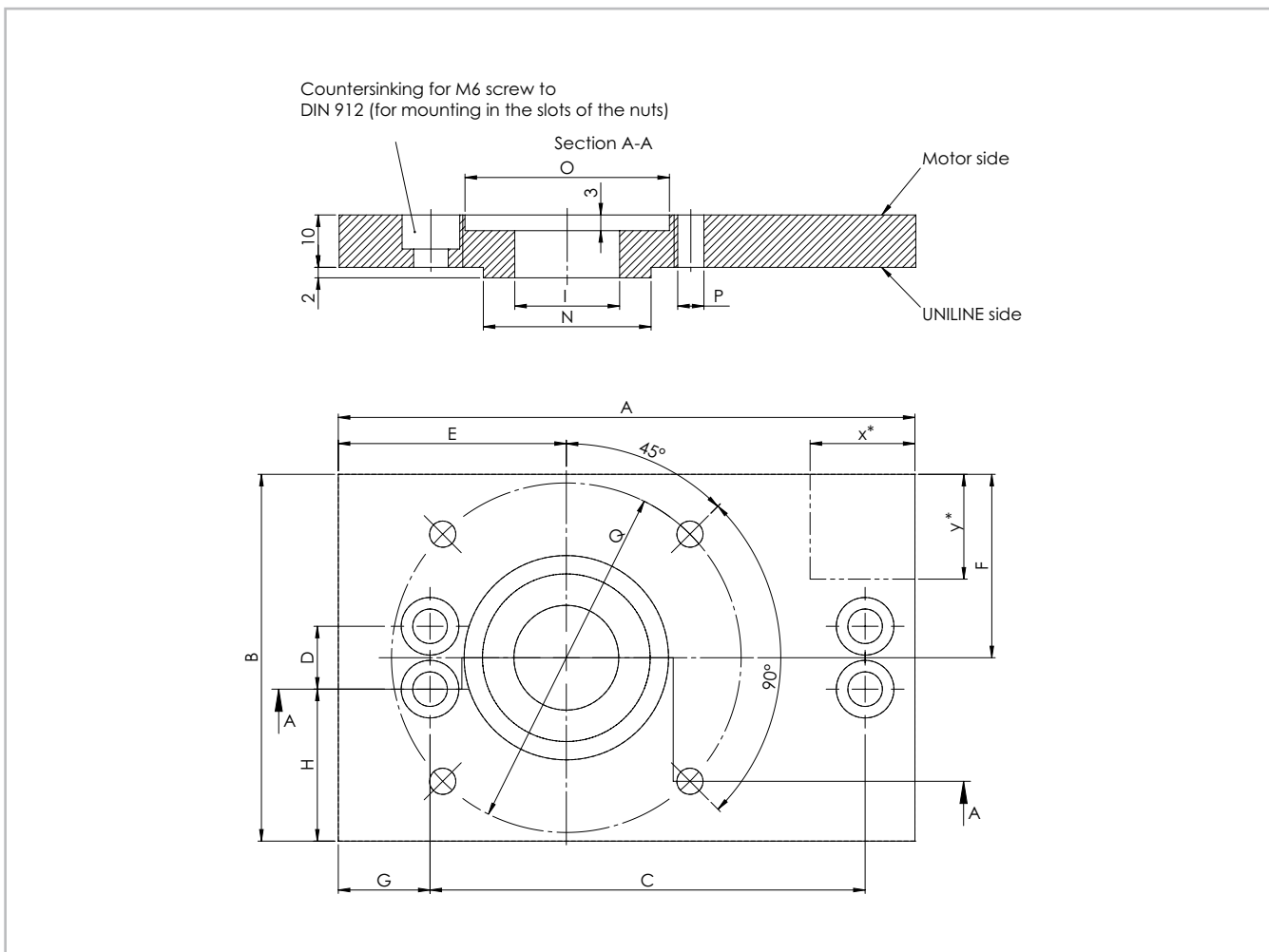

* The adapter plate must be provided with a recess in the X-Y area when using an ED75 linear unit. X = 20 mm; Y = 60 mm

Fig. 41

Size	NEMA Motors / Gearboxes
40	NEMA 23
55	NEMA 34
75	NEMA 42

Tab. 38

Size	A [mm]	B [mm]	C [mm]	D [mm]	E [mm]	F [mm]	G [mm]	H [mm]	I [mm]	N [mm]	O [mm]	P [mm]	Q [mm]
40	110	70	83	12	43.5	35	17.5	29	20	Ø 32	Ø 39	Ø 5	Ø 66.7
55	126	100	100	25	50.5	50	18	37.5	30	Ø 47	Ø 74	Ø 5.5	Ø 98.4
75	135	120	106	35	53.5	60	19	42.5	35	Ø 55	Ø 57	Ø 7.1	Ø 125.7

Tab. 39

Connection plates

T-connection plate APC-1

Connection plate for mounting the drive and deflection heads to the slider plate of a linear axis arranged at a right angle, relative to the latter (see p. 51). All plates are delivered with M6 x 10 screws to DIN 912 and T-nuts for mounting on the linear units.

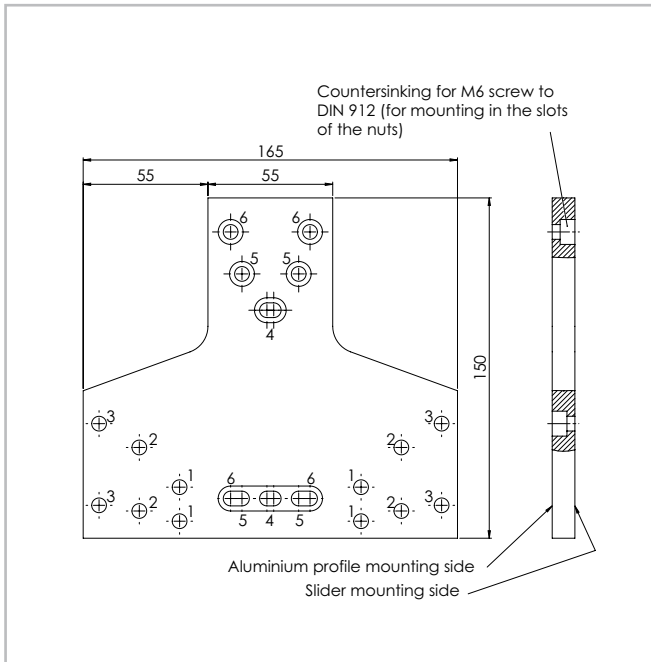

Fig. 42

Angle connection plate APC-2

Angle connection plate for mounting the slider plate with the aluminium profile to a linear axis arranged at a 90° angle (see p. 52). All plates are delivered with M6 x 10 screws to DIN 912 and T-nuts for mounting to the linear units.

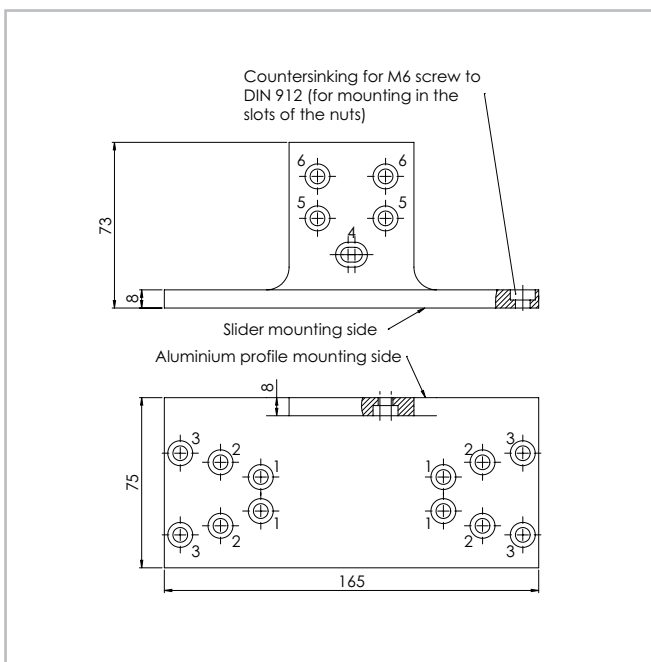

Fig. 43

Note

This adapter plate can be used with types E and ED only to a limited extent. For further information, please contact our Application Engineering Department.

Size	Fixing holes for the slider	Fixing holes for the profile
40	Holes 1	Holes 4
55	Holes 2	Holes 5
75	Holes 3	Holes 6

Tab. 40

Note

This adapter plate can be used with types E and ED only to a limited extent. For further information, please contact our Application Engineering Department.

Size	Fixing holes for the slider	Fixing holes for the profile
40	Holes 1	Holes 4
55	Holes 2	Holes 5
75	Holes 3	Holes 6

Tab. 41

X connection plate APC-3

X connection plate for mounting two sliders perpendicular to each other (see p. 53).

All plates are delivered with M6 x 10 screws to DIN 912 and T-nuts for mounting on the linear units.

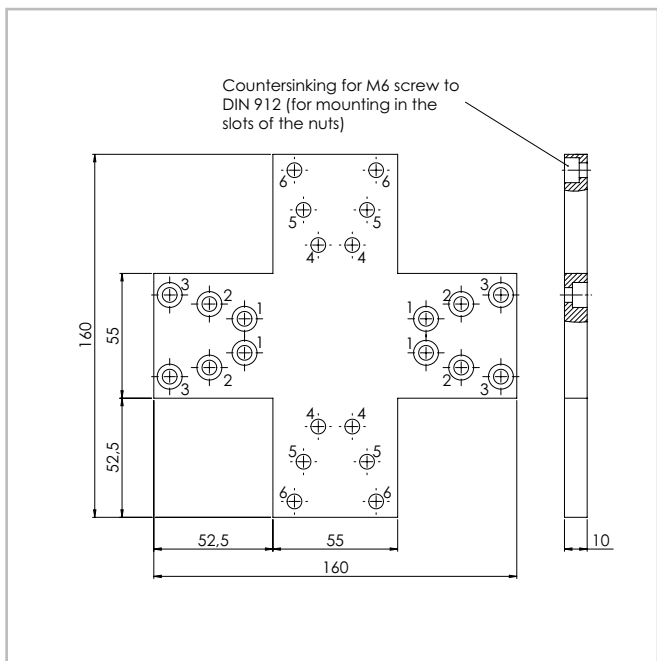

Fig. 44

Size	Fixing holes for the slider 1	Fixing holes for the slider 2
40	Holes 1	Holes 4
55	Holes 2	Holes 5
75	Holes 3	Holes 6

Tab. 42

Fixing clamp APF-2

Fixing clamp (for all sizes except A100) for simple mounting of a linear axis on a mounting surface or for connecting two units with or without connection plate (see p. 54).

A spacer* may be necessary.

*(Any spacer that may be necessary must be manufactured on site)

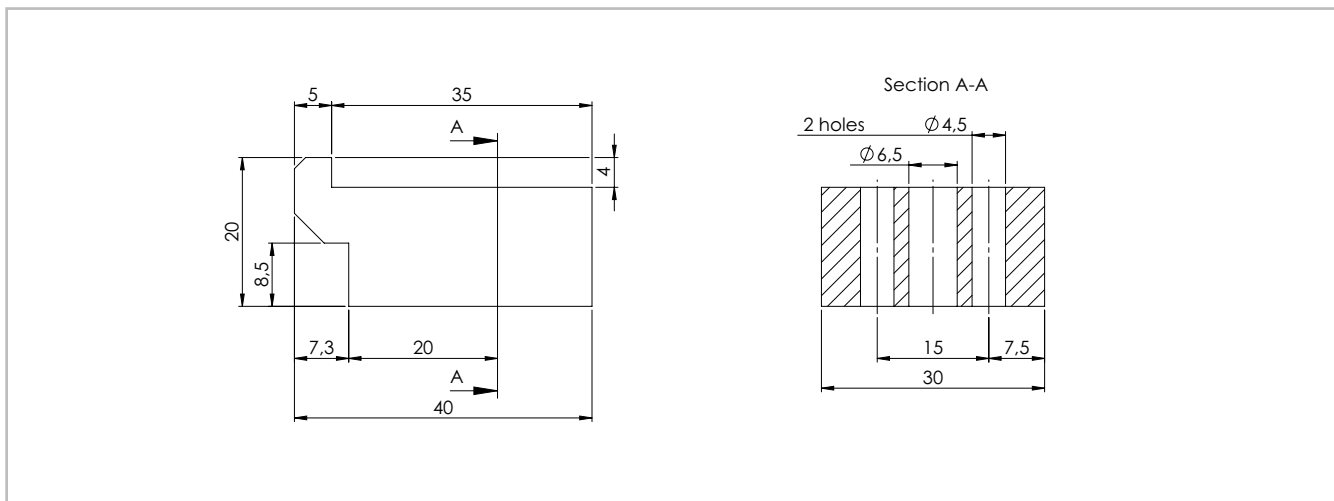

Fig. 45

T-nut

The maximum tightening torque is 10 Nm.

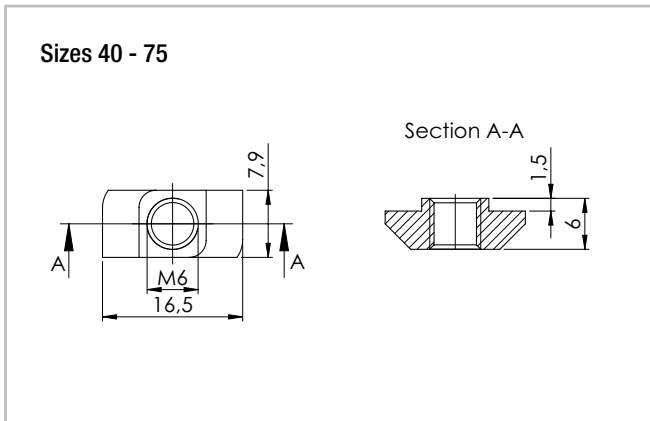
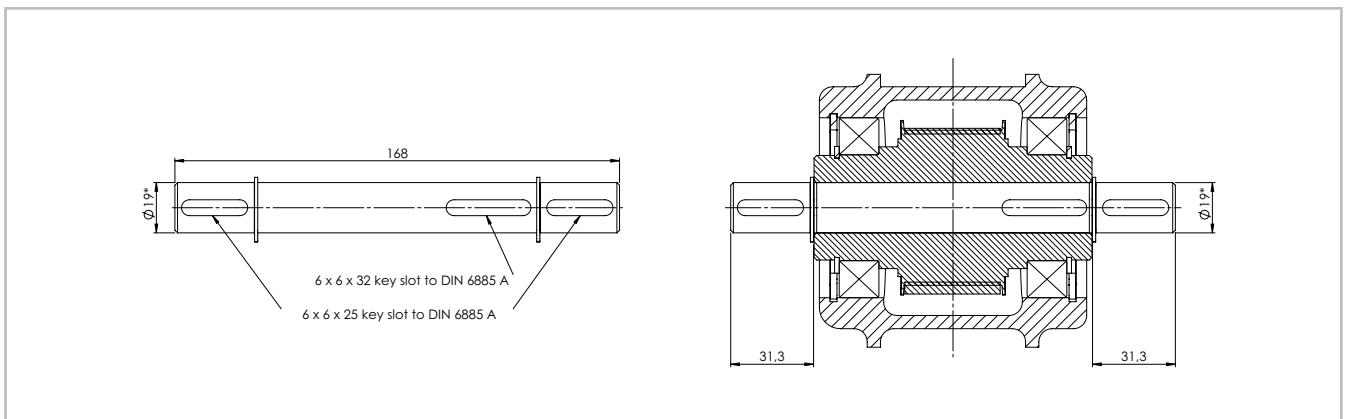

Fig. 46

A100 drive shaft

For type A100 with motor connection A only.



* Also available as shaft 20 mm in diameter

Fig. 47

A100 conical fitting device AC-10MA01

For type A100 with motor connection B only.

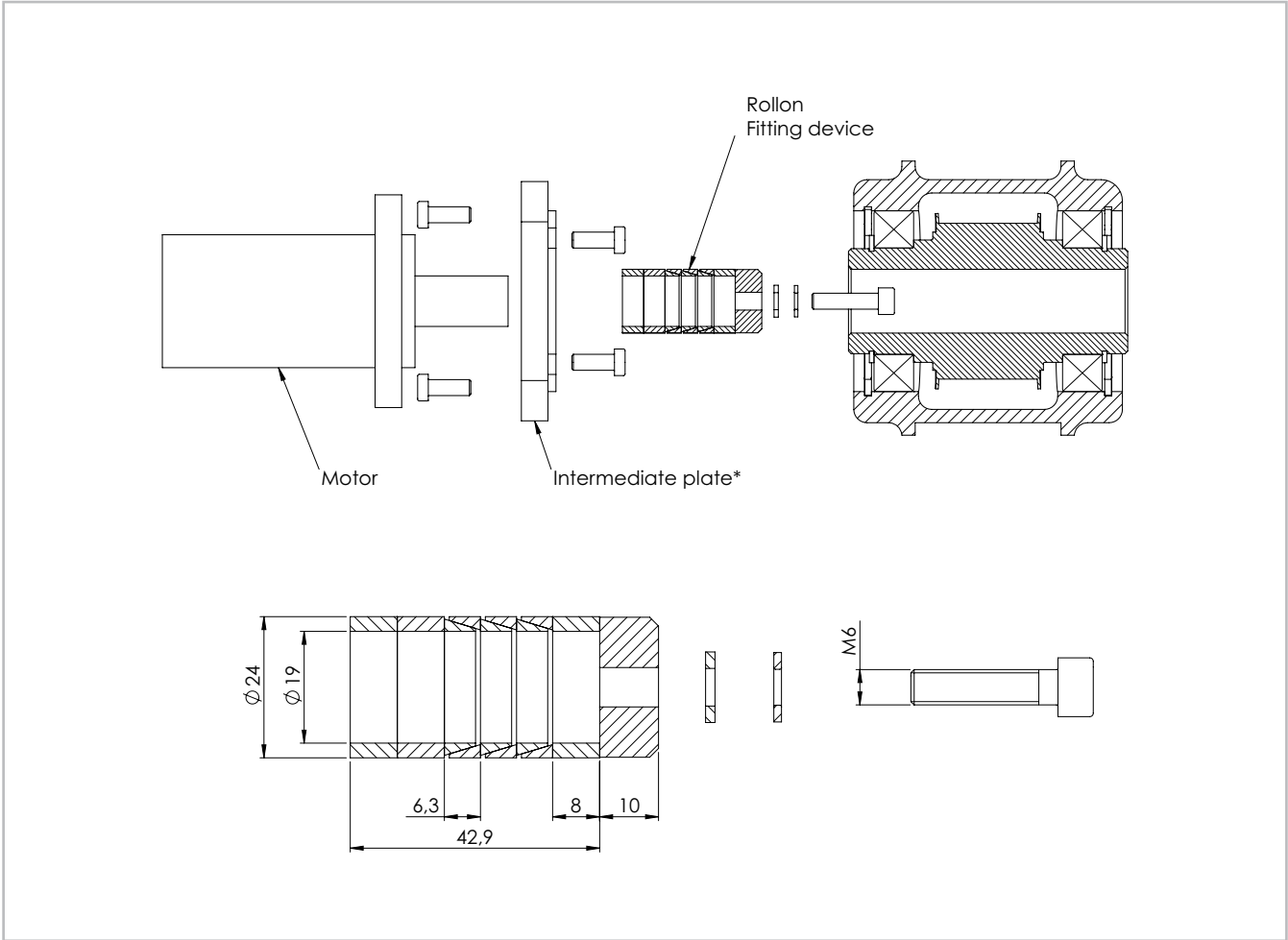

* Any intermediate plate that may be necessary must be manufactured on site.

Fig. 48

The maximum transferrable torque is 63 Nm.

Technical information

Static load

In the static load test, the radial load rating C_{Orad} , the axial load rating C_{Oax} , and the moments M_x , M_y and M_z indicate the maximum allowed load values (see p. 8ff). Higher loads will impair the running characteristics. To check the static load, a safety factor S_0 is used, which accounts for the special conditions of the application defined in more detail in the table below:

Safety factor S_0

Neither shocks nor vibrations, smooth and low-frequency change in direction High mounting accuracy, no elastic deformations	1 - 1.5
Normal assembly conditions	1.5 - 2
Shocks and vibrations, high-frequency changes in direction, substantial elastic deformations	2 - 3.5

Fig. 49

The ratio of the actual to the maximum allowed load must not be higher than the reciprocal value of the assumed safety factor S_0 .

$$\frac{P_{Orad}}{C_{Orad}} \leq \frac{1}{S_0} \quad \frac{P_{Oax}}{C_{Oax}} \leq \frac{1}{S_0} \quad \frac{M_1}{M_x} \leq \frac{1}{S_0} \quad \frac{M_2}{M_y} \leq \frac{1}{S_0} \quad \frac{M_3}{M_z} \leq \frac{1}{S_0}$$

Fig. 50

The above formulae apply to one load case. If one or more of the forces described are acting simultaneously, the following test must be carried out:

$$\frac{P_{Orad}}{C_{Orad}} + \frac{P_{Oax}}{C_{Oax}} + \frac{M_1}{M_x} + \frac{M_2}{M_y} + \frac{M_3}{M_z} \leq \frac{1}{S_0}$$

P_{Orad} = acting radial load (N)
 C_{Orad} = allowed radial load (N)
 P_{Oax} = acting axial load (N)
 C_{Oax} = allowed axial load (N)
 M_1, M_2, M_3 = external moments (Nm)
 M_x, M_y, M_z = maximum allowed moments in the different load directions (Nm)

Fig. 51

The safety factor S_0 can be at the lower limit given if the acting forces can be determined with sufficient accuracy. If shocks and vibrations act on the system, the higher value should be selected. In dynamic applications, higher safeties are required. For further information, please contact our Application Engineering Department.

Calculation formulae

Moments M_y and M_z for linear units with long slider plate

The allowed loads for the moments M_y and M_z depend on the length of the slider plate. The allowed moments M_{zn} and M_{yn} for each slider plate length are calculated by the following formulae:

$S_n = S_{min} + n \cdot \Delta S$ $M_{zn} = \left(1 + \frac{S_n - S_{min}}{K} \right) \cdot M_{zmin}$ $M_{yn} = \left(1 + \frac{S_n - S_{min}}{K} \right) \cdot M_{ymin}$	<p>M_{zn} = allowed moment (Nm)</p> <p>M_{zmin} = minimum values (Nm)</p> <p>M_{yn} = allowed moment (Nm)</p> <p>M_{ymin} = minimum values (Nm)</p> <p>S_n = length of the slider plate (mm)</p> <p>S_{min} = minimum length of the slider plate (mm)</p> <p>ΔS = factor of the change in slider length</p> <p>K = constant</p>
------------------------------------------------------------------------------------------------------------------------------------------------------------------------------	-----------------------------------------------------------------------------------------------------------------------------------------------------------------------------------------------------------------------------------------------------------------------------------------------------------------------------------------------------------------------------------------------------------------------------------------------

Fig. 52

Type	M_{ymin}	M_{zmin}	S_{min}	ΔS	K
A40L	22	61	240	10	74
A55L	82	239	310		110
A75L	287	852	440		155
C55L	213	39	310		130
C75L	674	116	440		155
E55L	165	239	310		110
E75L	575	852	440		155
ED75L (M_z)	1174	852	440		155
ED75L (M_y)	1174	852	440		270

Tab. 43

Moments M_y and M_z for linear units with two slider plates

The allowed loads for the moments M_y and M_z are related to the value for the distance between the centres of sliders. The allowed moments $M_{y,n}$ and $M_{z,n}$ for each distance between the centers of sliders are calculated by the following formulae:

$L_n = L_{min} + n \cdot \Delta L$ $M_y = \left(\frac{L_n}{L_{min}} \right) \cdot M_{y,min}$ $M_z = \left(\frac{L_n}{L_{min}} \right) \cdot M_{z,min}$	<p>M_y = allowed moment (Nm)</p> <p>M_z = allowed moment (Nm)</p> <p>$M_{y,min}$ = minimum values (Nm)</p> <p>$M_{z,min}$ = minimum values (Nm)</p> <p>L_n = distance between the centres of sliders (mm)</p> <p>L_{min} = minimum value for the distance between the centres of sliders (mm)</p> <p>ΔL = factor of the change in slider length</p>
----------------------------------------------------------------------------------------------------------------------------------------------------------	--------------------------------------------------------------------------------------------------------------------------------------------------------------------------------------------------------------------------------------------------------------------------------------------------------------------------------------------------------------------------------------------------------------------------------------------------

Fig. 53

Type	$M_{y,min}$	$M_{z,min}$	L_{min}	ΔL
A40D	70	193	235	5
A55D	225	652	300	5
A75D	771	2288	416	8
A100D	2851	4950	396	50
C55D	492	90	300	5
C75D	1809	312	416	8
E55D	450	652	300	5
E75D	1543	2288	416	8
ED75D	3619	2288	416	8

Tab. 44

Service life

Calculation of the service life

The dynamic load rating C is a conventional quantity used for calculating the service life. This load corresponds to a nominal service life of 100 km. The corresponding values for each liner unit are listed in Table 45 shown

below. The calculated service life, dynamic load rating and equivalent load are linked by the following formula:

$$L_{km} = 100 \text{ km} \cdot \left(\frac{C}{P} \cdot \frac{f_c}{f_i} \cdot f_h \right)^3$$

- L_{km} = theoretical service life (km)
- C = dynamic load rating (N)
- P = acting equivalent load (N)
- f_c = contact factor (see p. 44, tab. 47)
- f_i = service factor (see tab. 46)
- f_h = stroke factor (see p. 44, fig. 56)

Fig. 54

Type	A				C		E		ED	H		
Size	40	55	75	100	55	75	55	75	75	40	55	75
C* [N]	1530	4260	12280	30750	560	1470	4260	11280	9815	1530	4260	12280

* Note: for versions with long or double slider, the value for the dynamic load rating C must be doubled. An exception is the type A100L, see p. 8, tab. 1

Tab. 45

The effective equivalent load P is the sum of the forces and moments acting simultaneously on a slider. If these different load components are known, P is obtained from the following equation:

$$P = P_r + \left(\frac{P_a}{C_{0ax}} + \frac{M_1}{M_x} + \frac{M_2}{M_y} + \frac{M_3}{M_z} \right) \cdot C_{0rad}$$

Fig. 55

The external constants are assumed to be constant over time. Short-term loads that do not exceed the maximum load ratings have no relevant effect on the service life and can therefore be neglected in the calculation.

Service factor f_i

f_i	
neither shocks nor vibrations, smooth and low-frequency changes in direction; clean operating conditions; low speeds (<1 m/s)	1 - 1.5
slight vibrations; medium speeds; (1-2,5 m/s) and medium-high frequency of the changes in direction	1.5 - 2
shocks and vibrations; high speeds (>2.5 m/s) and high-frequency changes in direction; high contamination	2 - 3.5

Tab. 46

Contact factor f_c

f_c	
Standard slider	1
Long slider	0.8
Double slider	0.8

Tab. 47

Stroke factor f_h

The stroke factor f_h accounts for the higher stress on the raceways and rollers when short strokes are carried out at the same total run distance. The following diagram shows the corresponding values (for strokes above 1 m, f_h remains 1):

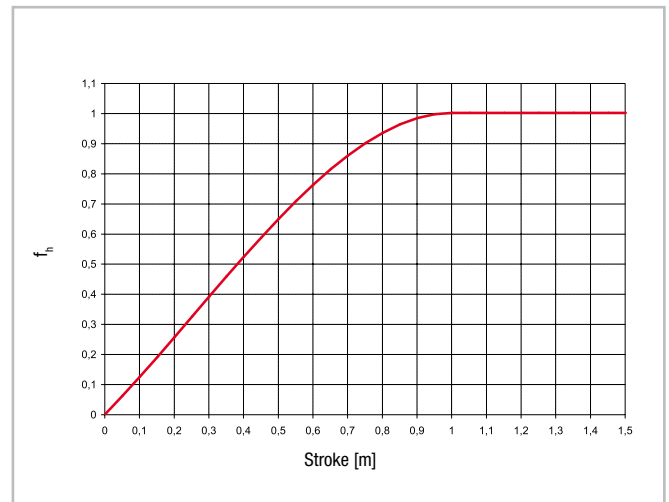

Fig. 56

Linear accuracy

The linear guiding accuracy for all types and sizes of the Uniline product family is 0.8 mm (see fig. 57).

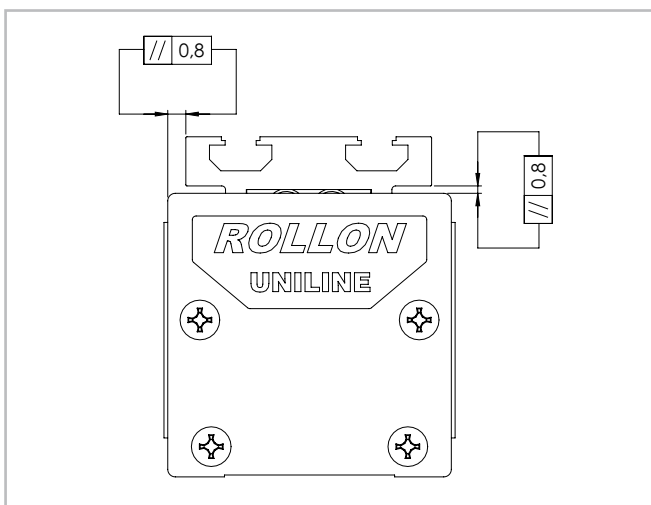

Fig. 57

Repeat accuracy

The repeat accuracy for all types and sizes of the Uniline product family is 0.1 mm.

Synchronous use of linear axes in pairs

If two axes are to be used in parallel using a connecting shaft, please specify when ordering, to make sure that the key slots can be aligned in the motor connection bores, relative to one another.

Linear units with longer strokes

A special joining technique of the slider rail and the aluminium profile provides combined linear axes with longer strokes. These units may be difficult to transport and may have to be shipped disassembled.

For the maximum strokes of the different sizes, please refer to the table below:

Size	Max. stroke [mm]
40	3500
55	5500
75	7500
100	5600

Tab. 48

Length and stroke tolerances

To always guarantee the required minimum stroke, the linear units have plus tolerances. These tolerances depend on the stroke:

For strokes <1 m: +0 to +10 mm

For strokes >1 m: +0 to +15 mm

For special lengths, the tolerances may be higher.

Please always make allowance for a sufficiently long stroke for limit switches, reference runs, etc.

Working temperature

The linear units can be used in a temperature range from -20 °C to +80 °C (-4 °F to +176 °F).

Lubrication

The raceways of the guide rails in the Uniline linear axes are prelubricated. To achieve the calculated service life, a lubrication film always has to be present between the raceway and the roller, which also provides anticorrosion protection to the ground raceways. An approximate value for the lubrication period is every 100 km or every six months. The recommended lubricant is a lithium-based roller bearing grease of medium consistency.

Lubrication of the raceways

Proper lubrication under normal conditions:

- reduces friction
- reduces wear
- reduces stress on the contact faces
- reduces running noise

Lubricants	Thickeners	Temperature range [°C]	Dynamic viscosity [mPas]
Roller bearing grease	Lithium soap	-30 to +170	<4500

Tab. 49

Relubrication of the guide rails of types A and E

These types have a lubricating conduit on the side of the slider plate (type A100 is equipped with lubricating nipple) through which the lubricant can be applied directly to the raceways. Lubrication can take place in one of two ways:

1. Relubrication using the grease gun:

This is done by introducing the tip of the grease gun into the conduit at the slider plate and pressing the grease inside (see fig. 58). Please note that prior to the actual lubrication of the rail raceways the conduit is filled, which is why a sufficient amount of grease must be used.

2. Automatic lubrication system:

The outlet of the lubrication system must be connected to the linear unit via an adapter*, which is screwed into the hole of the slider plate conduit. This solution has the advantage that the rail raceways can be relubricated without a machine stop.

*(Any adapter that may be necessary must be manufactured on site)



Fig. 58

Relubrication of the guide rails of types C and ED

1. Slide the slider plate to one side
2. Press the toothed belt at the height of half the traverse slightly inside, until you can see the internal rails (see Fig. 59). It may be necessary to release or loosen the belt tension. See chapter Belt tension (see p. 48).
3. Apply a sufficient amount of grease to the raceways.
4. If required-re-establish the recommended belt tension (see p. 48).



Fig. 59

5. Then slide the slider plate forth and back over the entire traverse, in order to distribute the grease over the entire rail length.

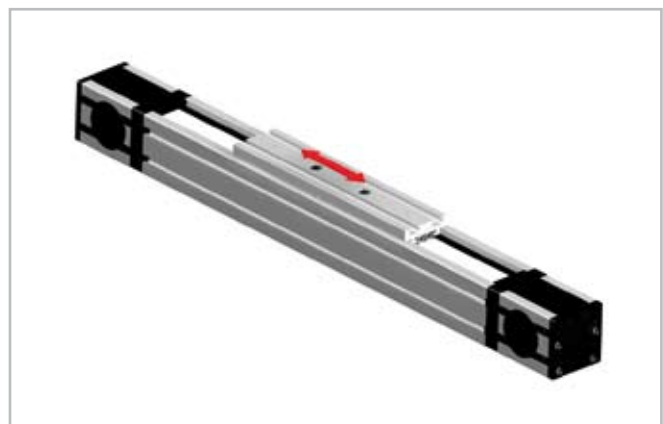

Fig. 60

Cleaning the guide rails

It is always recommended cleaning the slider rail prior to any relubrication, in order to remove grease residues. This can be done while performing maintenance work or a scheduled machine stop.

1. Unscrew the safety screws C (on top of the slider plate) from the belt tensioning device A (see fig. 61).
2. Also completely unscrew the belt tensioning screws B and remove the belt tensioning devices A from their housings.
3. Lift the toothed belt until the guide rails can be seen.
Important: Make sure that the side seal is not damaged.
4. Clean the rail raceways with a clean and dry cloth. Make sure that all grease and dirt residues from previous work processes are removed.
To ensure that the rails are cleaned over their entire length, the slider plate should be moved once over its entire length.
5. Apply a sufficient amount of grease to the raceways.
- 6- Re-insert the belt tensioning devices A into their housings and mount the belt tensioning screws B. Re-adjust the belt tension (see p. 48).
7. Fasten the safety screws C.

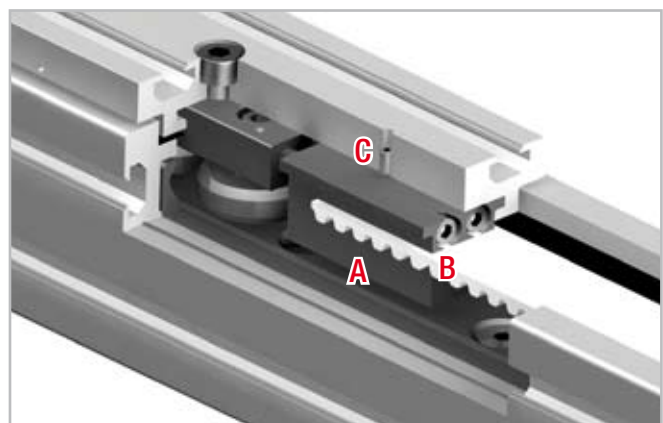

Fig. 61

Belt tension

All Uniline linear axes are delivered with a standard belt tension, which is sufficient for most applications (see tab. 50).

Size	40	55	75	ED75	100
Belt tension [N]	160	220	800	1000	1000

Tab. 50

The belt tensioning system for sizes 40 to 75 at the ends of the slider plates and at the deflection head for size 100 allows the toothed belt tension to be set in accordance with requirements.

To set it for sizes 40 to 75, the following steps must be followed (the reference values are standard values):

1. Determine the deviation of the belt tension from the standard value.
2. Figures 63 and 64 opposite show how often the belt tensioning screws B must be turned until the desired deviation of the belt tension is reached.
3. The toothed belt length (m) is:
 - $L = 2 \times \text{stroke (m)} + 0.515 \text{ m (size 40)}$;
 - $L = 2 \times \text{stroke (m)} + 0.630 \text{ m (size 55)}$;
 - $L = 2 \times \text{stroke (m)} + 0.792 \text{ m (size 75)}$.
4. Multiply the number of turns (see item 2) by the toothed belt length m (see item 3).
5. Unscrew the safety screw C.
6. Turn the belt tensioning screws B in accordance with the above explanation. Re-tighten the safety screw C.

Example:

Increasing the belt tension from 220 N to 330 N for an A55 - 1070:

1. deviation = $330 \text{ N} - 220 \text{ N} = 110 \text{ N}$.
2. Figures 63 and 64 show that the value by which the belt tensioning screws B must be turned to increase the belt tension by 110 N is 0.5 turns.
3. Formula for calculating the toothed belt length:
 - $L = 2 \times \text{stroke (m)} + 0.630 \text{ m} = 2 \times 1.070 + 0.630 = 2.77 \text{ m}$.

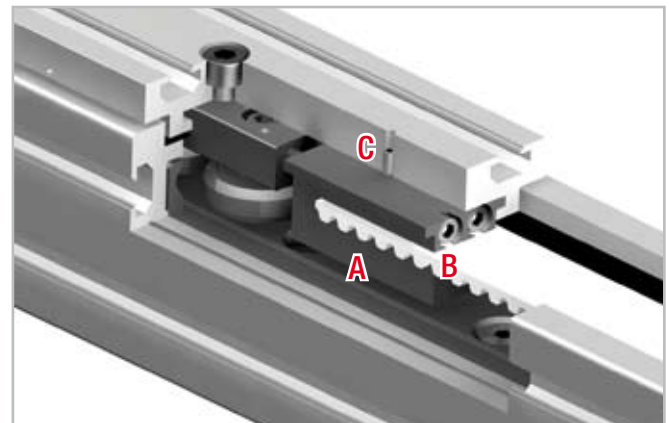

Fig. 62

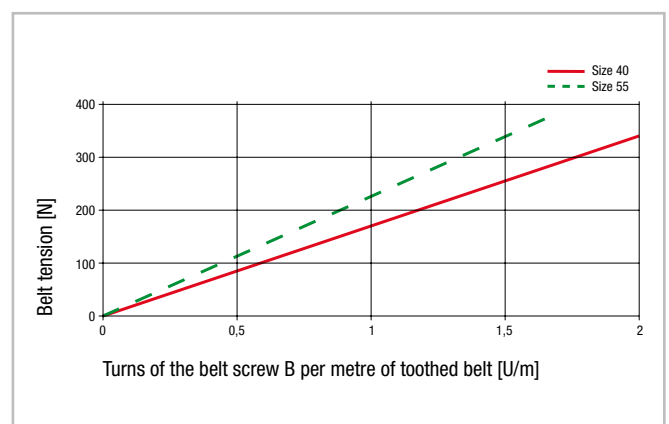

Fig. 63

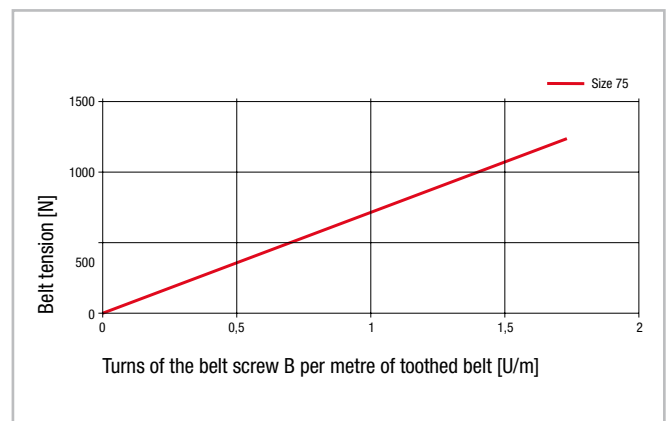

Fig. 64

4. This means that the required number of turns is:

$$0.5 \text{ rpm} \times 2.77 \text{ m} = 1.4 \text{ turns.}$$

5. Unscrew the safety screw C.

6. Turn the belt tensioning screws B by 1.4 turns with the aid of an external reference.

7. Re-tighten the safety screw C.

To set it for size 100, the following steps must be followed (the reference values are standard values):

1. Determine the deviation of the belt tension from the standard value.
2. Figure 66 opposite shows how far the belt deflection pulley must be offset at the deflection head via the set screws A, in order to obtain the desired belt tension.
3. Multiply the offset by the stroke length.
4. Turn the set screws A in accordance with the above explanation.



Fig. 65

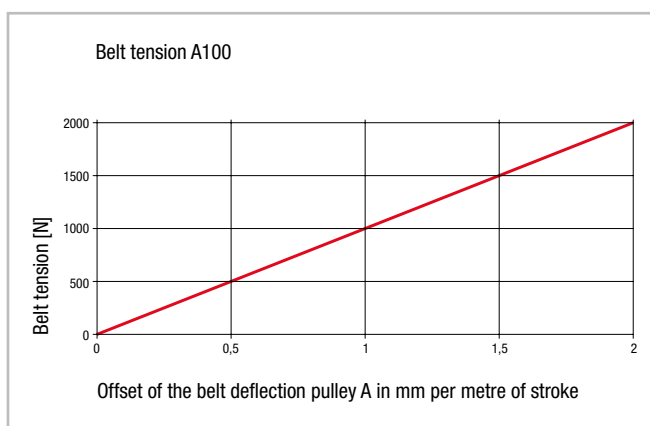

Fig. 66

Example:

Increasing the belt tension from 1000 N auf 1500 N for an A100-2000:

1. Deviation = 1500 N - 1000 N = 500 N.
2. The graphic shows that the offset of the belt deflection pulley required for increasing the belt tension by 500 N is 0.5 mm per metre of stroke.
 Offset = 0.5 mm x 2 (stroke) = 1 mm

Note:

If the linear unit is used such that the load acts directly on the toothed belt, it is important not to exceed the specified values for the belt tension, because otherwise the positional accuracy and stability of the toothed belt cannot be guaranteed. If higher values are required for the belt tension, please contact our Application Engineering Department.

Determination of the motor torque

The torque C_m required at the drive head of the linear axis is calculated by the following formula:

$$C_m = C_v + \left(F \cdot \frac{D_p}{2} \right)$$

C_m = torque of the motor (Nm)
 C_v = standard moment at no load (Nm)
 F = force acting on the toothed belt (N)
 D_p = pitch diameter of pulley (m)

Fig. 67

Max. motor torque at the standard belt tension

Size 40 [Nm]	Size 55 [Nm]	Size 75 [Nm]	Size ED75 [Nm]	Size 100 [Nm]
2.16	4.55	20.37	25.46	30.24

Tab. 51

Installation instructions

Motor adapter plates AC2 and AC1-P, sizes 40 - 75

To connect the linear units to the motor and gearbox, suitable adapter plates must be used. These plates are delivered by Rollon in two different designs (see p. 34ff, chapter Accessories), except for size A100. The standard plates are already provided with the holes required for mounting to the linear unit. The fixing holes must be made on site. Make sure that

the mounted plate does not collide with the stroke of the traversing slider plate.

Connection to motor and gearbox

1. Attach the motor adapter plate to the motor or gearbox.
2. Connect the T-nuts by introducing the screws without tightening them and align the nuts in parallel to the slots of the nuts.
3. Introduce the connecting shaft into the drive head by aligning the key in the key slot.
4. Attach the motor adapter plate to the drive head of the linear axis by means of nuts (see p. 38, Accessories). Ensure correct fit of the adapter plate.

Note:

- The connecting plates for the Uniline A40 are delivered with four fixing holes, even though only two holes are required for the connection. The presence of four holes give the plate a symmetric design.
- Owing to the constructive form of the aluminium profile, only three fixing holes can be used for the Uniline C series. (see p. 25, fig. 27).



Fig. 68

T-connection plate APC-1, sizes 40 - 75

Connecting two linear axes by means of the T-connection plate APC-1 (see p. 36, chapter Accessories). To mount the above-mentioned configuration, the following steps should be carried out:

1. Fix the connection plate by introducing the screws into the prepared holes on the APC-1 (see fig. 69).
2. Connect the T-nuts by introducing the screws without tightening them and align the nuts in parallel to the slots of the nuts of the unit.
3. Place the plate against the long side of unit 1 and tighten the screws. Please make sure that the nuts in the slots were rotated by 90°.
4. To fasten the plate to unit 2, introduce the screws from the the long side of unit 1 (see fig. 70).
5. Connect the T-nuts by introducing the screws without tightening them and align the nuts in parallel to the slots of the nuts of the slider plate of unit 2.
6. Place the plate against the slider plate and tighten the screws. Important: Please make sure that the nuts in the slots were rotated by 90°.



Fig. 69

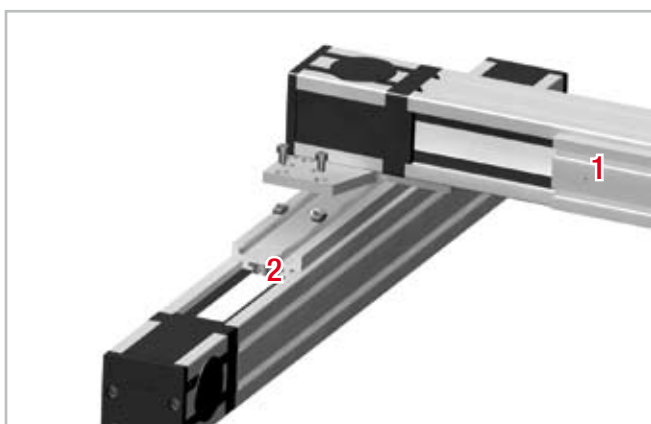

Fig. 70

Example 1 System consisting of 2 X axes and 1 Y axis

The connection of the two units is effected by means of the parallel slider plates and the drive heads. For this configuration, we recommend using our connection plate APC-1 (see p. 36).

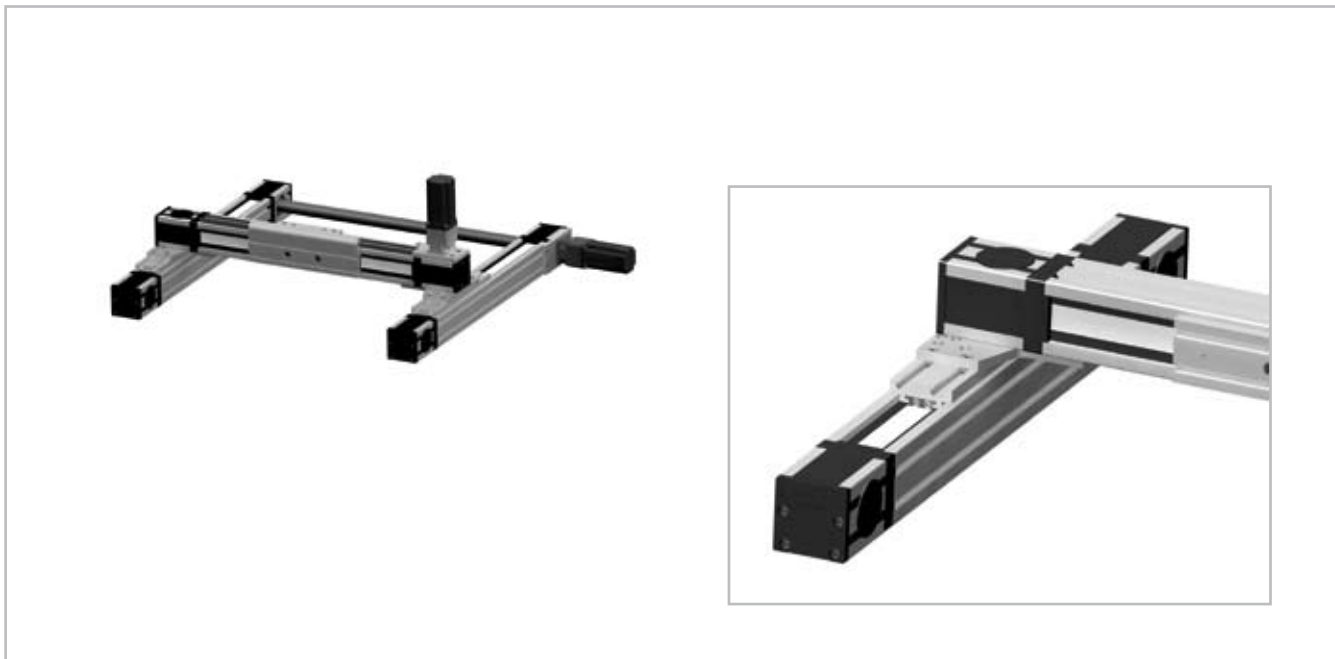

Fig. 71

Angle connection plate APC-2, sizes 40 - 75

Connecting two linear axes by means of the angle connection plate APC-2 (see p. 36). To mount the above-mentioned configuration, the following steps should be carried out:

1. Introduce the screws to be used for the connection to unit 1 into the prepared holes (see p. 72).
2. Connect the T-nuts by introducing the screws without tightening them and align the nuts in parallel to the slots of the nuts of the slider plates.
3. Place the plate against the slider plate and tighten the screws. Please make sure that the nuts in the slots were rotated by 90°.
4. To fix the connection plate to unit 2, introduce the screws into the prepared holes on the short plate side (see fig. 73).
5. Connect the T-nuts by introducing the screws without tightening them and align the nuts in parallel to the slots of the nuts of the aluminium profile of unit 2.
6. Place the connection plate against the slider plate and tighten the screws. Please make sure that the nuts in the slots were rotated by 90°.

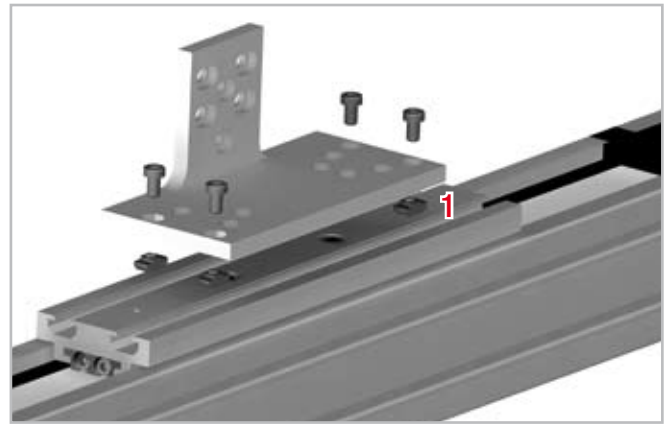

Fig. 72

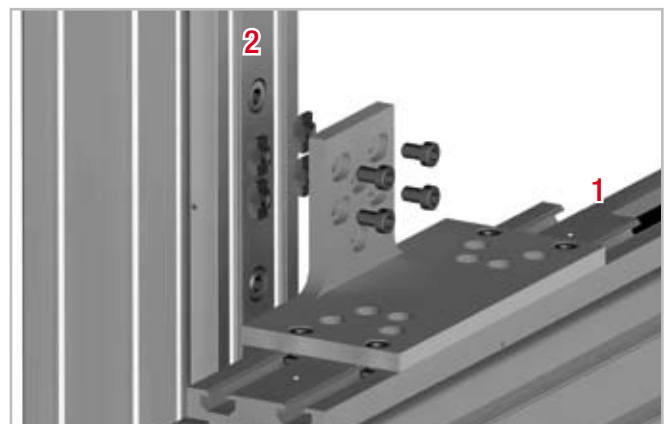

Fig. 73

Example 2 – System consisting of 1 X axis and 1 Z axis

With this configuration, the Z axis is connected to the slider plate of the X axis by means of the angle connection plate APC-2 (see p. 36).

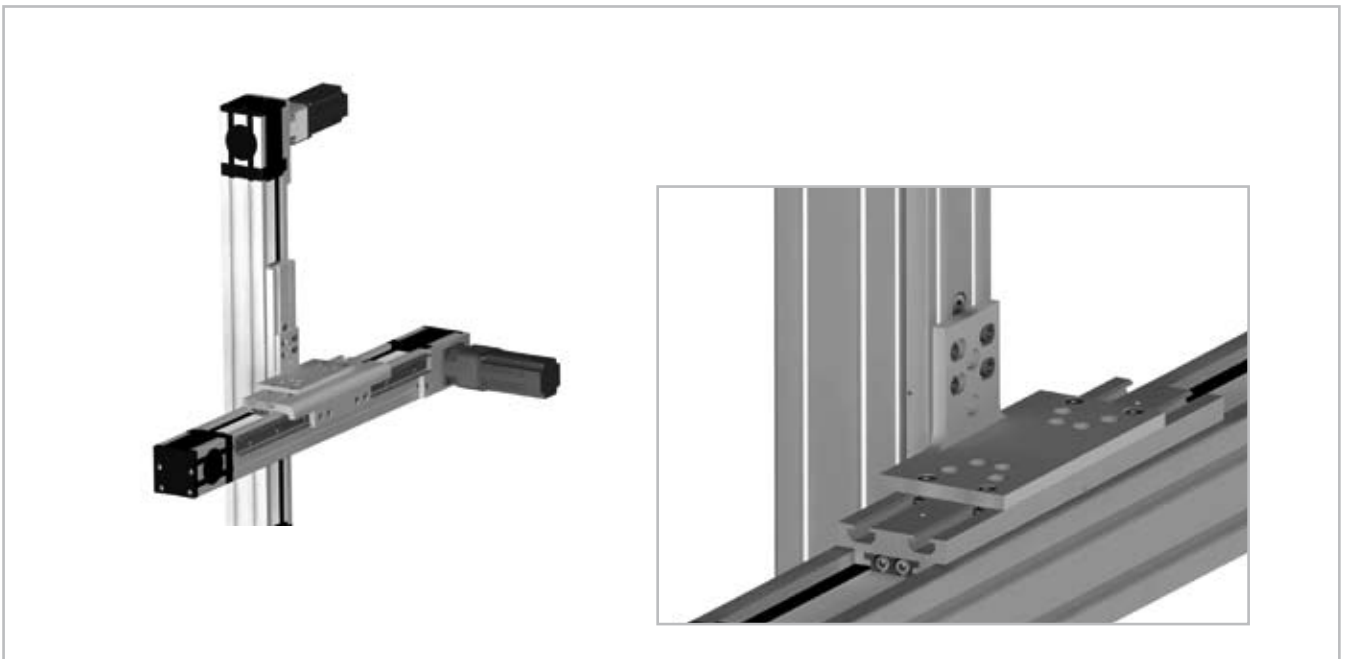

Fig. 74

X connection plate APC-3, sizes 40 - 75

Connecting two linear axes by means of the X connection plate APC-3 (see p. 37, chapter Accessories). To mount the above-mentioned configuration, the following steps should be carried out:

1. Introduce the the screws from one side of the connection plate into the prepared holes (see fig. 75).
2. Connect the T-nuts by introducing the screws without tightening them and align the nuts in parallel to the slots of the nuts of the slider plate of unit 1.
3. Place the connection plate against the slider plate and tighten the screws. Please make sure that the nuts in the slots were rotated by 90°.
4. Introduce the screws from the other side of the connection plate (see fig. 76).
5. Connect the T-nuts by introducing the screws without tightening them and align the nuts in parallel to the slots of the nuts of the slider plate of unit 2.
6. Place the connection plate against the slider plate and tighten the screws. Please make sure that the nuts in the slots were rotated by 90°.

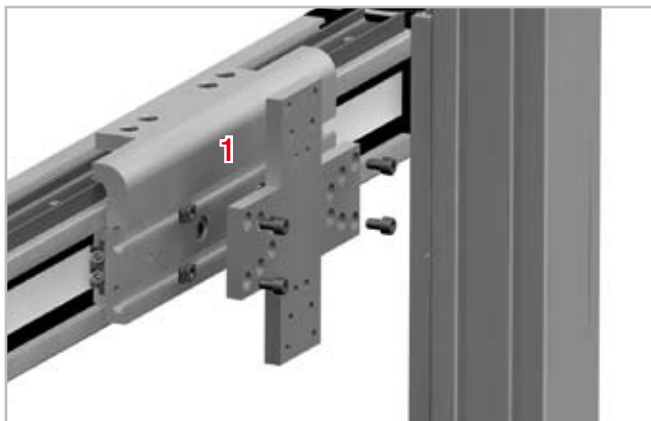

Fig. 75

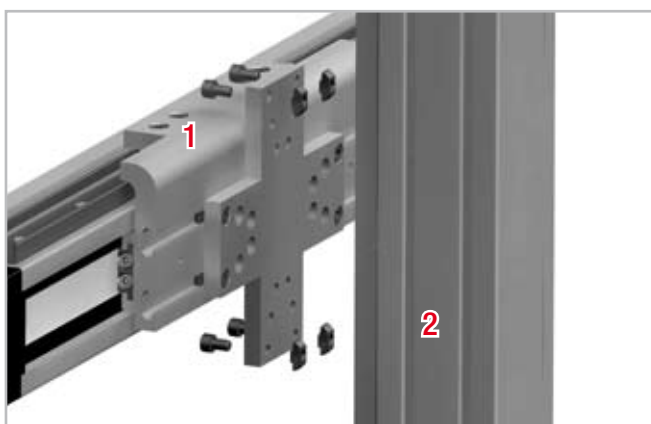

Fig. 76

Example 3 – System consisting of 2 X axes, 1 Y axis and 1 Z axis

Connecting four linear units to give a 3-axis gantry. The vertical axis is arranged self-supporting on the central unit. To do so, connect the two slider plates to each other, using the X connection plate APC-3.

The connection of the two parallel axes to the central unit is effected by means of the T-connection plate APC-1 (see p. 36ff).

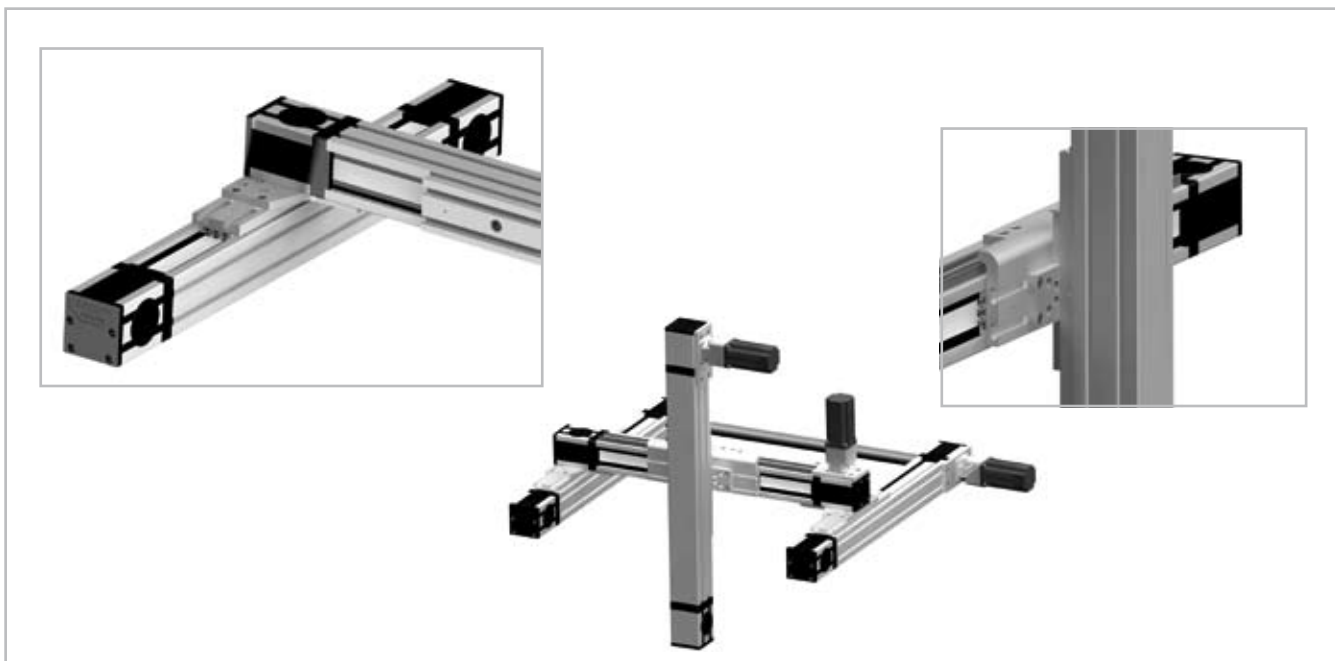

Fig. 77

Fixing clamp APF-2, sizes 40 - 75

Connecting two linear axes by means of the fixing clamps APF-2 (see p. 37, chapter Accessories). To mount the above-mentioned configuration, the following steps should be carried out:

1. Introduce the fastening screws into the clamp and, if necessary, place a spacer* between clamp and slider plate.
*(Any spacer that may be necessary must be manufactured on site)
2. Connect the T-nuts by introducing the screws without tightening them and align the nuts in parallel to the slots of the nuts of the slider plates.
3. Introduce the projecting part of the clamp into the lower slot of the nut of the aluminium profile of unit 1.
4. Position the clamp lengthwise according to the desired position of the slider plate of unit 2.
5. Tighten the fastening screws. Please make sure that the nuts in the slots were rotated by 90°.
6. Repeat this operation for the required number of fixing clamps.

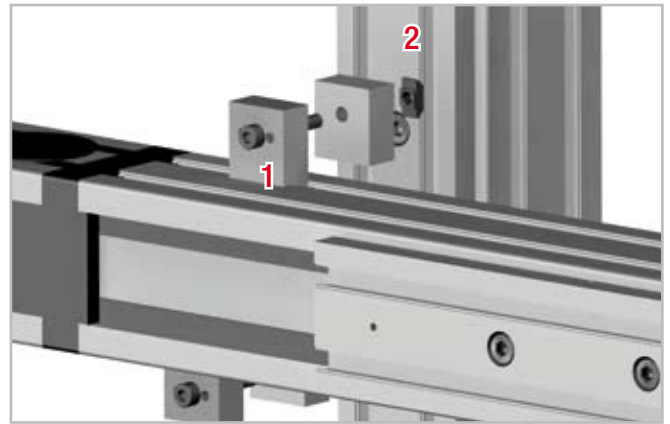

Fig. 78

Example 4 – System consisting of 1 Y axis and 2 Z axes

The connection of the Y axis to the parallel slider plates is effected via the fixing clamps APF-2 (see p. 37).

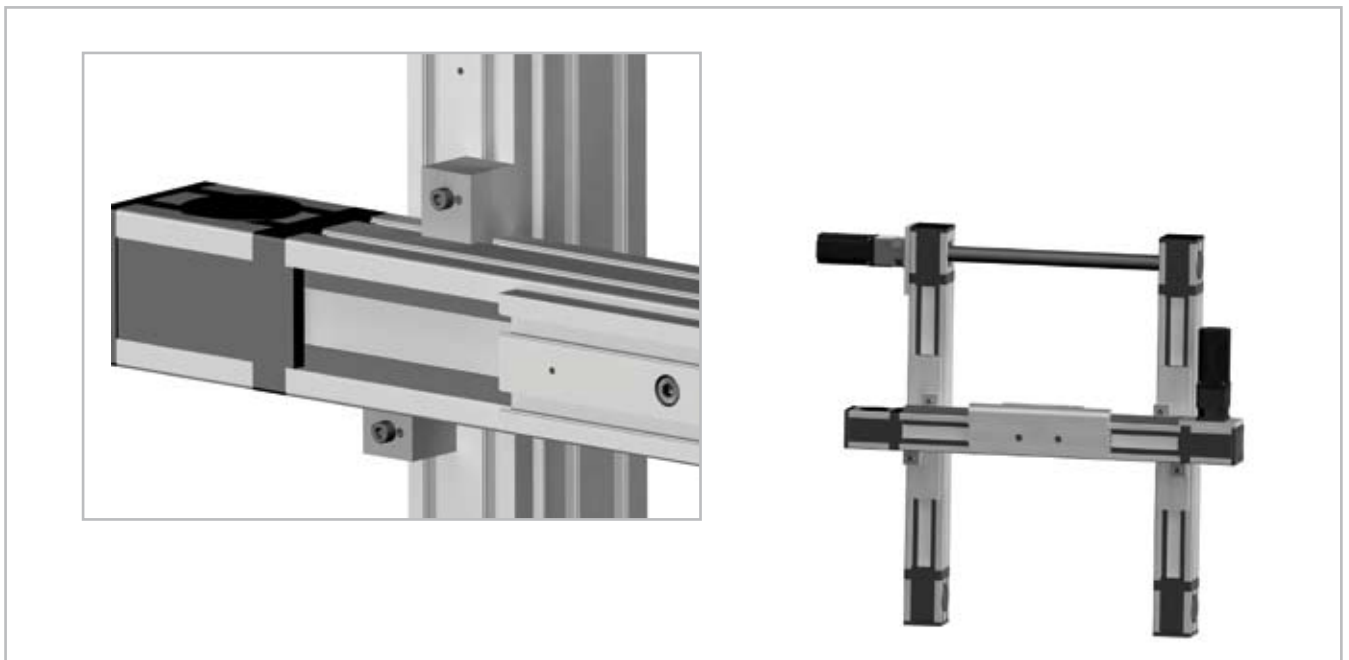

Fig. 79

 Notes

Ordering key

Version with standard slider

A	75	1530	P	
			Motor connection holes in inch, optional,	<i>see tab. 52</i>
		Stroke	<i>see p. 16ff Product dimensions</i>	
	Size	<i>see p. 8ff Technical data</i>		
Type	<i>see p. 8ff Technical data</i>			

Ordering example: A075-1530

Ordering information: The sizes are always specified with three digits, the strokes always with four digits with prefixed zeros.

Version with long slider

A	40	1400	400	L	P	
					Motor connection holes in inch, optional,	<i>s. tab. 52</i>
				Indices of long slider plate,	<i>chapter Product dimensions</i>	
			Length of slider plate	<i>see p. 16ff Product dimensions</i>		
		Stroke	<i>s. p. 16ff Product dimensions</i>			
	Size	<i>see p. 8ff Technical data</i>				
Type	<i>see p. 8ff Technical data</i>					

Ordering example: A040-1400-400L

Ordering information: The sizes are always specified with three digits, the strokes always with four digits with prefixed zeros.

Version with double slider

A	55	1190	500	D	P	
					Motor connection holes in inch, optional	<i>see tab. 52</i>
				Indices of double slider plate,	<i>chapter Product dimensions</i>	
			Distance of the centres of slider plates	<i>see p. 16ff Product dimensions</i>		
		Stroke	<i>see p. 16ff Product dimensions</i>			
	Size	<i>see p. 8ff Technical data</i>				
Type	<i>see p. 8ff Technical data</i>					

Ordering example: A055-1190-0500D

Ordering information: The sizes are always specified with three digits, the strokes and the distance of centres always with four digits with prefixed zeros

Accessories

Standard motor adapter plate

A	40	AC2	
	Size	<i>see p. 34</i>	
Type (except A100)			

Ordering example: A040-AC2

Ordering information: The sizes are always specified with three digits with prefixed zeros.

NEMA motor adapter plates

A	40	AC1	
	Size	<i>see p. 35</i>	
Type (except A100)			

Ordering example: A040-AC1

Ordering information: The sizes are always specified with three digits with prefixed zeros.

T-connection plate	Order code: APC-1 (for all sizes except A100), s. p. 36
Angle connection plate	Order code: APC-2 (for all sizes except A100), s. p. 36
X connection plate	Order code: APC-3 (for all sizes except A100), s. p. 37
Fixing clamp	Order code: APF-2 (for all sizes except A100), s. p. 37

Motor connection bores

Hole [Ø]	Size			
	40	55	75	100
Metric [mm] with slot for key	10G8 / 3js9	10G8 / 3js9	14G8 / 5js9	19G8 / 6js9
		12G8 / 4js9	16G8 / 5js9	20G8 / 6js9
		14G8 / 5js9	19G8 / 6js9	
Metric [mm] for compression coupling			18	
			24	
Inch [in] with slot for key	$\frac{3}{8}$ / $\frac{1}{8}$	$\frac{3}{8}$ / $\frac{1}{8}$	$\frac{5}{8}$ / $\frac{3}{16}$	
		$\frac{1}{2}$ / $\frac{1}{8}$		
		$\frac{5}{8}$ / $\frac{3}{16}$		

The highlighted connection bores are standard connections

Tab. 52

Metric: key seat for keys to DIN 6885 form A

Inch: key seat for keys to BS 46 Part 1: 1958

Portfolio



COMPACT RAIL

Rugged roller sliders with innovative self adjustment



MINIATURE MONO RAIL

Miniature format profile guideways with unique ball design



CURVILINE

Curvilinear rails for constant and variable radii



TELESCOPIC RAIL

Smooth-running telescopic linear bearing drawer slides with low deflection under heavy loads

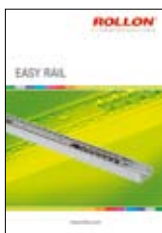

EASY RAIL

Compact, versatile linear bearings



X-RAIL

Roller embossed stainless steel profiles for the use in rough environments



MONO RAIL

Profile guideways for highest degrees of precision

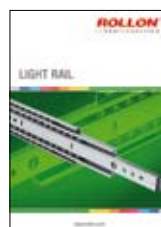

LIGHT RAIL

Full and partial extension, lightweight drawer slides

Fold-out ordering key

To make use of this product catalogue as simple as possible for you, we have included the following easy-to-read chart:

Your advantages:

- Description and order code easy to read at a glance
- Simplified selection of the right product
- Links to detailed descriptions in the catalog



Italy

ROLLON S.r.l.

Via Trieste 26
I-20871 Vimercate (MB)
Tel.: (+39) 039 62 59 1
Fax: (+39) 039 62 59 205
E-Mail: infocom@rollon.it
www.rollon.it

Germany

ROLLON GmbH

Bonner Strasse 317-319
D-40589 Düsseldorf
Tel.: (+49) 211 95 747 0
Fax: (+49) 211 95 747 100
E-Mail: info@rollon.de
www.rollon.de

France

ROLLON S.A.R.L.

Les Jardins d'Eole, 2 allée des Séquoias
F-69760 Limonest
Tel.: (+33) (0)4 74 71 93 30
Fax: (+33) (0)4 74 71 95 31
E-Mail: infocom@rollon.fr
www.rollon.fr

Netherlands

ROLLON B.V.

Ringbaan Zuid 8
6905 DB Zevenaar
Tel.: (+31) 316 581 999
Fax: (+31) 316 341 236
E-Mail: info@rollon.nl
www.rollon.nl

USA

ROLLON Corporation

101 Bilby Road. Suite B
Hackettstown, NJ 07840
Tel.: (+1) 973 300 5492
Fax: (+1) 908 852 2714
E-Mail: info@rolloncorp.com
www.rolloncorp.com

All addresses of our sales partners worldwide can also be found on the internet at www.rollon.com