

FMS Telemetry Systems

## RTM MP Bi-Directional, Radio-Based Signal Transmission for Rotating Machinery

- **Signals: Encoder, Digital, Analog, Force Sensor:**  
Parallel transmission to/from rotating machinery for various applications
- **Elimination of Slip-Rings:**  
Reliable radio-based transmission for highest reliability and process safety
- **Easy Retrofit:**  
Simple system concept and quick installation, compact components suite most any application
- **Maintenance-Free:**  
Robust design with embedded components provide for reliable service in the harshest environment



### RTM MP System

The RTM MP Telemetry System was developed for transmitting various signals in parallel from rotating machinery:

- 2 x Encoder
- 8 x Digital
- 1 x Analog
- 2 x Force sensor

The RTM MP System is applied where signal transmission utilizing slip rings is no longer practical. The costs involved for an expansion or and upgrade of existing slip ring signal transmission can be substantial due to the complexity of the required components or modifications to the machine itself.

Many RTM MP Systems are applied as a substitute for defective or aged slip-ring systems where the repairs are cost prohibitive or even impossible as spare parts are no longer available.

Through the use of robust components for maintenance free operation and a simple system concept for easy installation, the RTM MP System provides the telemetry solution of choice for the installed base of buncher and twister stranding machines.

### Functional description

The RTM MP System consists of only three main components: One transceiver inside the rotating part of the machine, and both one transceiver and one decoding module on the outside of the machine, normally mounted near the operator's station.

The transceiver located inside the rotating part of the machine is connected via cabling to each of the signal sources. Process signals can be sent in both directions between the rotating and static parts of the machine. The real time data transmission between the two transceivers is highly reliable, stable and insensitive to radio disturbances or other RTM MP Systems operating within close proximity.

The decoding module on the static side is responsible for the data processing and serves as the link to the PLC or other controllers.

**RTM MP** | System Overview

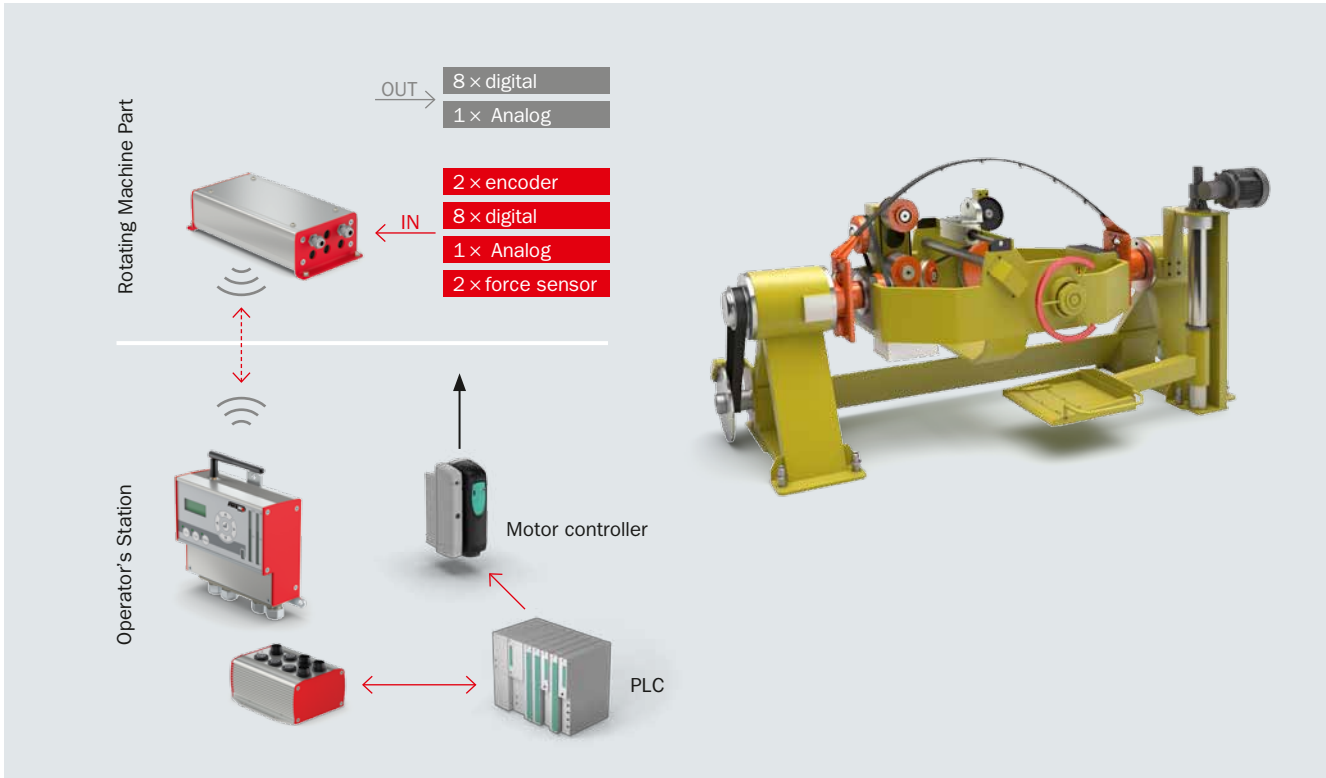

**RTM MP** | Main Modules

**RTM MP Transceiver  
 EMGZ482T.PLUS**

Located within the rotating machine section

**RTM MP Transceiver  
 EMGZ482R.MP**

Located near the operator's station

**RTM MP Decoding Module  
 EMGZ443.MP.R**

Located near the operator's station



- Compact dimensions
- Single housing with integrated antenna
- Inputs
  - 2 x Encoder
  - 1 x Analog
  - 8 x Digital
  - 2 x Force sensor
- Outputs
  - 1 x Analog
  - 8 x Digital
- Integrated measuring amplifiers for the force sensors
- Directly connected to 24 VDC power supply of machine

- Outputs
  - 2 x Analog (from force sensors)
- Interface to decoding module

- Outputs
  - 2 x Encoder
  - 1 x Analog
  - 8 x Digital
- Inputs
  - 1 x Analog
  - 8 x Digital

**RTM MP Transceiver (rotating section) EMGZ 482T.PLUS.MP | Technical Data**

<b>Encoder inputs</b>	2 channels max. 100 kHz
<b>Analog input</b>	0 to 10 VDC or 4 to 20 mA
<b>Force measuring roller inputs</b>	2 sensors with strain gauges @ 350 Ω (0 to 5.4 mV, max. 7.4 mV)
<b>Digital input</b>	8 x; 5 to 36 VDC
<b>Digital output</b>	8 x; max. 100 mA / output (source)
<b>Analog output</b>	0 to 10 VDC and 4 to 20 mA
<b>Wireless interface</b>	2.44 GHz
<b>Encoder supply</b>	HTL (15...30 VDC; max. 2 W)
<b>Sensor supply</b>	3.0 VDC, max. 20 mA, high precision
<b>Power supply</b>	24 VDC via slip-rings (18 to 36 VDC/ 10 W max. 0.5 A)
<b>Resolution A/D-converter</b>	± 8192 Digit (14 Bit)
<b>Measuring error</b>	< 0.05 % FS
<b>Temperature range</b>	0 to 50°C [32 to 122 °F]
<b>Protection class</b>	IP 52
<b>Weight</b>	1.50 kg [3.3 lbs]

**RTM MP Transceiver (operator's station) EMGZ 482R.MP | Technical Data**

<b>Force measuring roller outputs</b>	2 x 0 to 10 VDC or 4 to 20 mA
<b>Relay output (radio lost)</b>	1 relay contact; DC: 24 V/0.5 A/12 W; AC: 24 V/0.5 A/62.12 VA
<b>Displays</b>	LCD 2 x 8 digits, 5 mm(0.2 in.), 2 LED rows for tension indication Supply voltage indicator
<b>Wireless interface</b>	2.44 GHz
<b>Power supply</b>	24 VDC (18 to 36 VDC) / 10 W (max. 0.5 A)
<b>Propagation delay</b>	5.5 ms
<b>Resolution D/A-converter</b>	0 to 4096 (12 Bit)
<b>Temperature range</b>	0 to 50°C [32 to 122 °F]
<b>Protection class</b>	IP 52
<b>Weight</b>	0.65 kg [1.43 lbs]

**RTM MP Decoding Module EMGZ 443MP.R | Technical Data**

<b>Encoder outputs</b>	2 channels max. 100 kHz
<b>Analogue outputs</b>	0 to 10 VDC or 4 to 20 mA
<b>Digital outputs</b>	8 outputs; max. 100 mA / output (source)
<b>Digital inputs</b>	Digital inputs 5 to 36 VDC
<b>Analog input</b>	0 to 10 VDC or 4 to 20 mA
<b>Power supply</b>	24 VDC (18 to 36 VDC) max. 0.4 A
<b>Power consumption</b>	EMGZ 443MP.R = max. 15 W; EMGZ 443MP.T = max. 10 W
<b>Temperature range</b>	0 to 50°C [32 to 122 °F]
<b>Protection class</b>	IP 52
<b>Weight</b>	0.6 kg [1.32 lbs]

**RTM MP System | Radio Certification ETSI**

<b>Magnitude of Test (Coverage)</b>	Article 3.2 of Directive 1999/5/EC (R&TTE Directive)
<b>Certification</b>	ETSI EN 300 440-2 V1.5.1 (2009-03); ETSI EN 300 440-1 V1.3.1 (2009-03)

**RTM X42 System | FCC Certification USA, Canada**

<b>Magnitude of Test (Coverage)</b>	Class A digital device, pursuant to Part 15 of the FCC Rules
<b>Certification</b>	FCC Registration #: 0020311882

**RTM X42 System | CAB Radio Certification for Japan**

<b>Magnitude of Test (Coverage)</b>	Low power data communi. FXD; Art. 38-24, Paragraph 1 of radio law
<b>Certification</b>	Article 2, Clause 1 Item 19, Certification ID #: 202WWSM10126721

**Telemetry Systems** | RTM X42 System for Tension Measurement and Control for Cage and Tubular Type Stranding Machines

**RTM X42 Tension Measuring System**



**RTM X42.CC Control Center**



**RTM X42.BC Brake Control**



**Additional FMS Products for the Wire & Cable Industry**

FMS offers a wide range of measuring sensors that can be used in combination with our telemetry systems. With numerous styles and available load ratings from 3 to 8000 N, it is likely that we can provide a solution for your application. FMS measuring amplifiers and tension controllers are applicable when wireless data transmission is not required or when wiring of the components is not an issue. You can rely on our years of experience and proven technology in this field. Contact us directly to learn how we are able to assist you with your application.

**Telemetry Systems** | Accessories

**RMGZ 200  
 Measuring Rollers**



**RMGZ 300  
 Measuring Rollers**



**EMGZ Measuring Amplifiers**



**CMGZ Tension Controllers**



**RTM MP** | Typical Application in Bow Type Stranding Machine

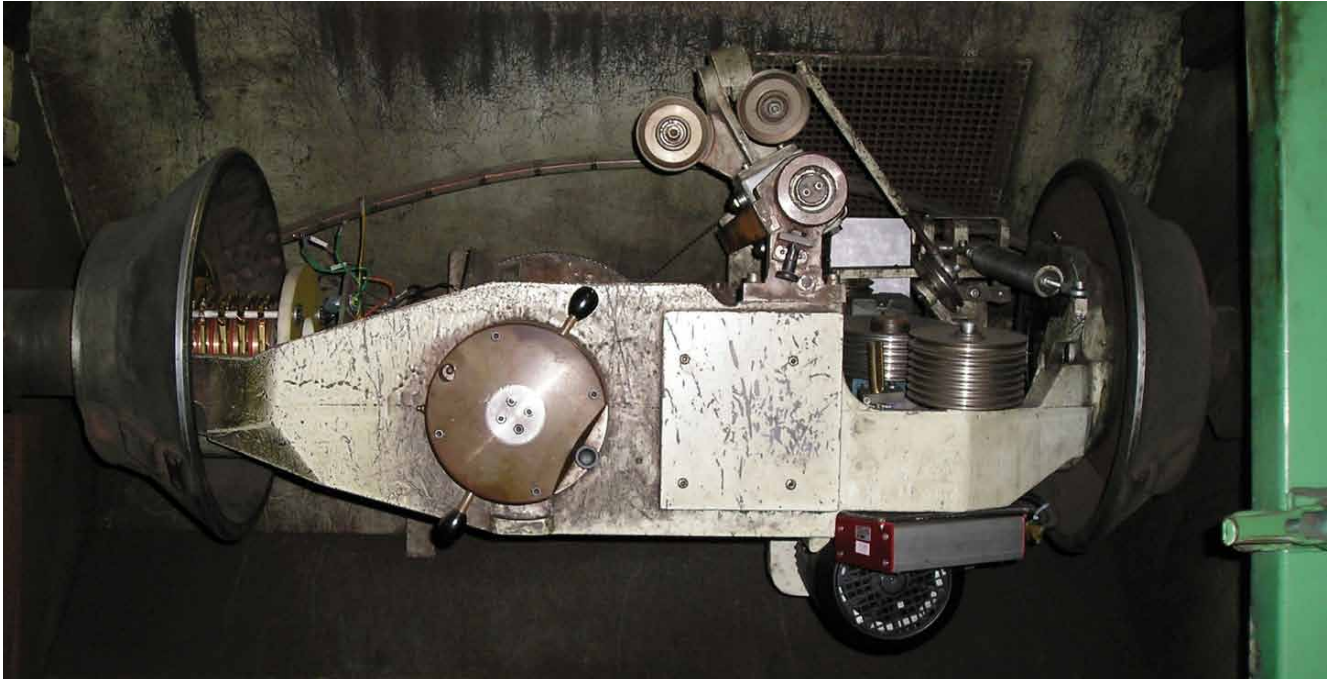

**RTM MP** | Typical Application in Bow Type Stranding Machine



**RTM MP Transceiver in Rotating Part EMGZ 482T.PLUS** | Dimensions in mm or [in]

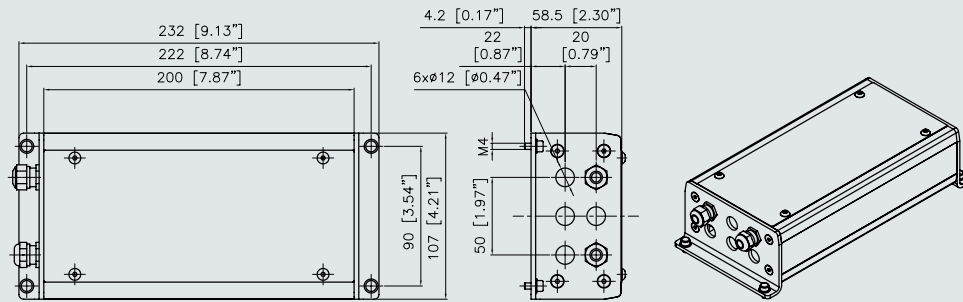

**RTM MP Transceiver near Operator's Station EMGZ 482R.MP.R** | Dimensions in mm or [in]

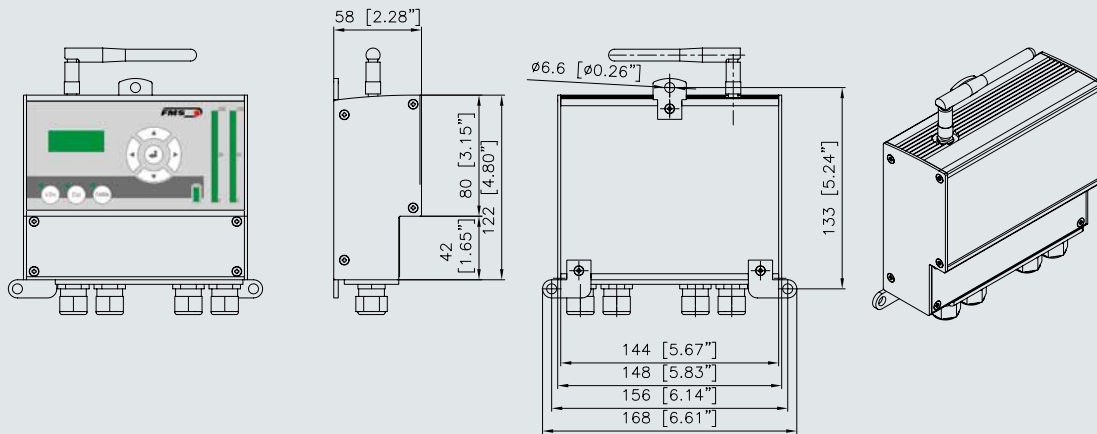

**RTM MP Decoding Module near Operator's Station EMGZ443MP** | Dimensions in mm or [in]

