

Belt Scales for Bulk Conveyors

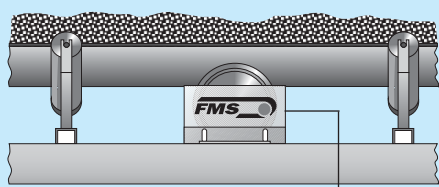

BMGZ 600 universal weighing electronic



4-20 mA
RS 232 etc.

Universal electronic unit for the measurement of daily and total throughput, actual flowrate and belt speed. Various interfaces, such as RS232, analogue outputs, pulse outputs for connection of printer, remote counter or analogue meter. Ready for installation in cabinets or wall-mounting.

BMGZ 600 in a steel cabinet

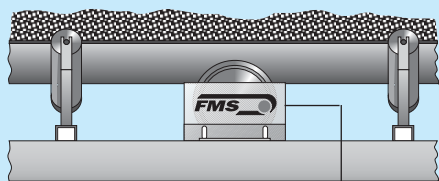

4-20 mA
RS 232 etc.

This version of the BMGZ 600 is especially suitable for tough working conditions in mobile units such as crushers and screening units. The electronic unit is available as a single or double channel version. As an option, a fitting frame with rubber buffers can be supplied.

Application of FMS Belt Scales for bulk conveyors

The FMS belt scale weighs every kind of bulk goods, such as gravel, broken stones, chalk, coal, dung or grain.

Owing to its compact dimension and the universal assembling parts which are also delivered, it can be mounted easily without difficulty in nearly every conveyor.

A microprocessor-based electronic unit determines through continuous detection of weight and speed of the belt among other the flowrate and integrates it to calculate the weight on the load and daily throughput.

All FMS belt scales are provided with analog and digital outputs and also a serial interface RS 232 as standard equipment. They are therefore also suitable for applications where materials must be proportionately discharged or controlled and regulated.

Example 1:
Shiploader for gravel and stones.
Capacity 800 t/h.
The FMS belt scale determines the quantity loaded on every ship.

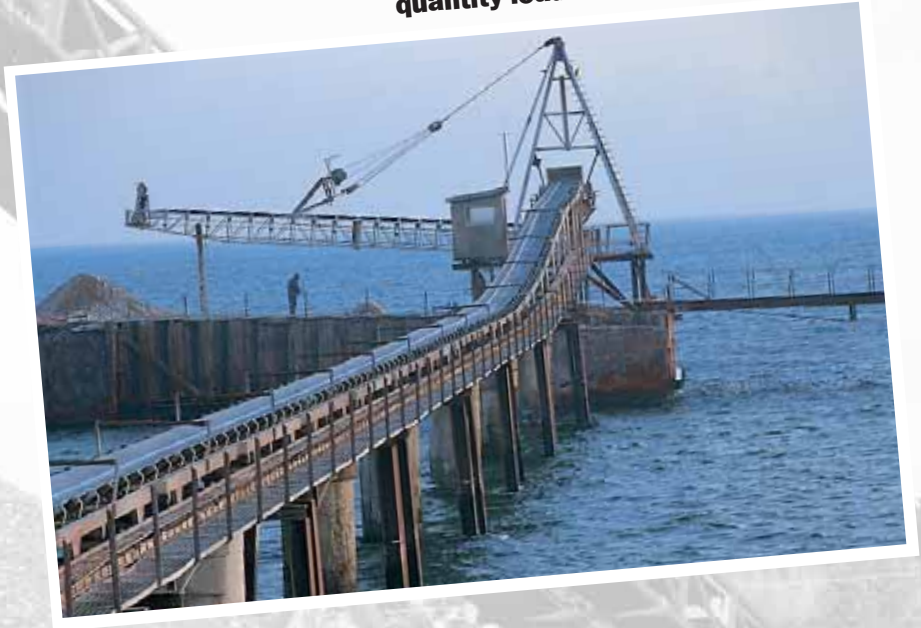

Example 2:
Mobile crusher for reconditioning of rubbish.
Capacity 150 t/h.
A FMS belt scale determines the recycled mass on which the crusher's turnover is based.



Application of FMS Belt Scales

Example 3:
FMS belt weigher
in mobile crusher
for stones.
Capacity 200 t/h.



Example 4:
FMS belt weigher in
discharging conveyor of
a stationary crusher.
Capacity 400 t/h.



Example 5:
FMS belt weigher in a
shiplouder at the Rhein
river. Capacity 700t/h.



FMS Belt Scales for Bulk Conveyors

Operational Principle Constructive Design

Functional principle

The FMS belt scale is operating according to the principle:

$$\text{Flowrate} = \text{weight} \times \text{speed}$$

The FMS measuring roller has to be fixed between two stations of idle rollers under the belt. The measuring roller whose shape corresponds to the shape of the belt is supported on both sides on FMS force measuring bearings. The measuring bearings take up the force directly at its origin and do not show any sensitivity to belt direction. The measurement of belt speed is achieved by means of a pulse generator which is integrated in one of the force measuring bearings.

Advantages

- Simple design through use of the FMS force measuring bearings
- Compact device through integration of force and speed measurement on the roller shaft
- Measuring bearings and cabling protected against down falling material
- Maintenance-free

Construction Design

The force measuring bearing consists of an inner ring which houses the bearing and an outer ring which is fixed to the frame of the scale. The inner and outer rings are elastically connected only by a web, which is the actual measuring element. When the bearing is loaded with force, the web is subjected to bending stresses. These stresses are measured with strain gauges attached to the web root. Dowel pins restrict the relative motion between inner and outer ring to prevent permanent deformation when the Force Measuring Bearing is overloaded.

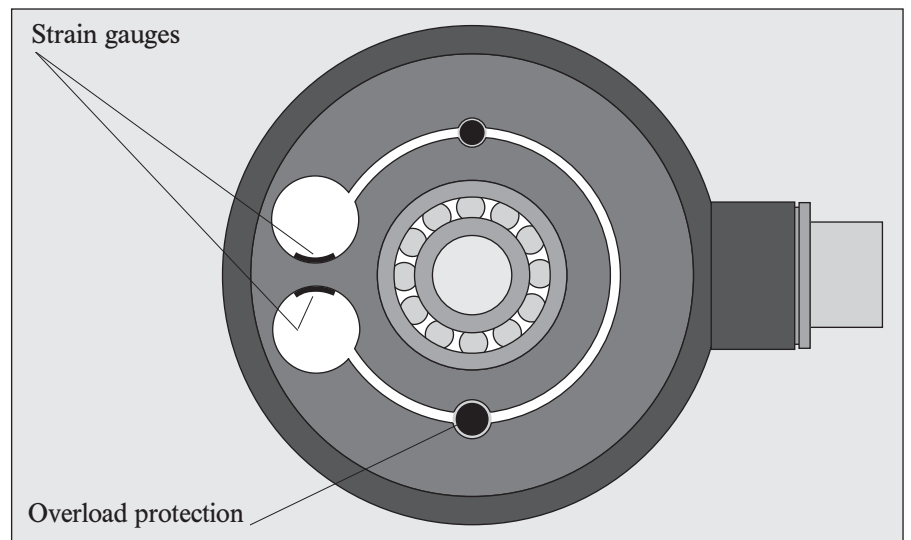
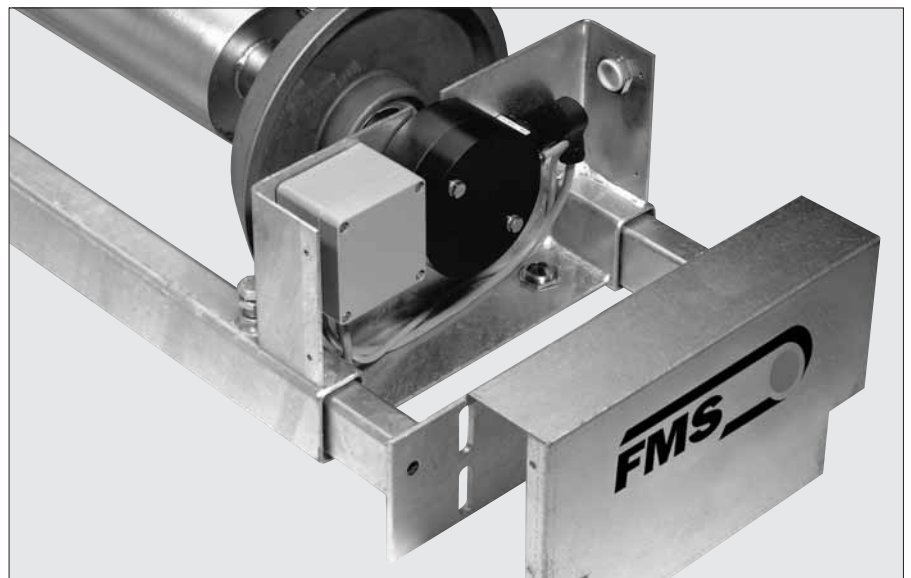
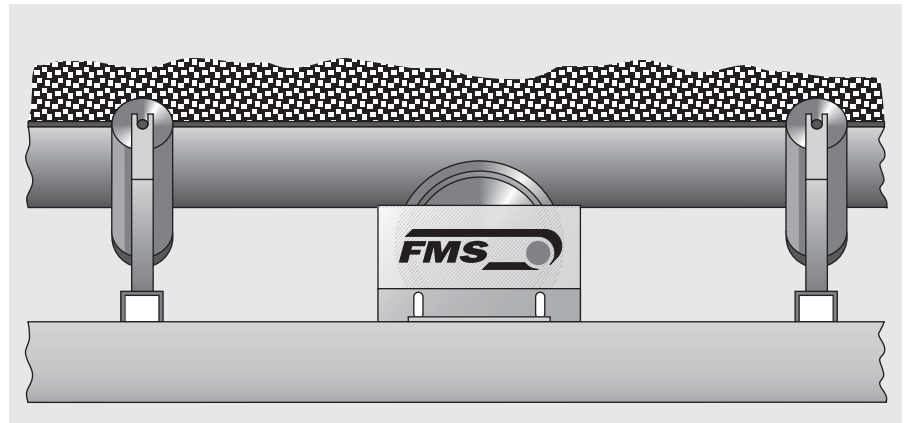



Flat FMS Measuring Roller

The mounting height of 150 mm makes it possible to embed the flat FMS measuring roller even in the most narrow of spaces, e.g. in movable screens or crushers.

The flat measuring roller is not only used on flat conveying belts, but it offers an alternative for troughed conveying belts.

The measuring roller support is adjustable and can therefore be mounted in any framework.

The universal mounting brackets (see page 7) supplied with the scale make it easy to fit it into already existing plants.

All parts are galvanised, to provide a durable protection against rust.

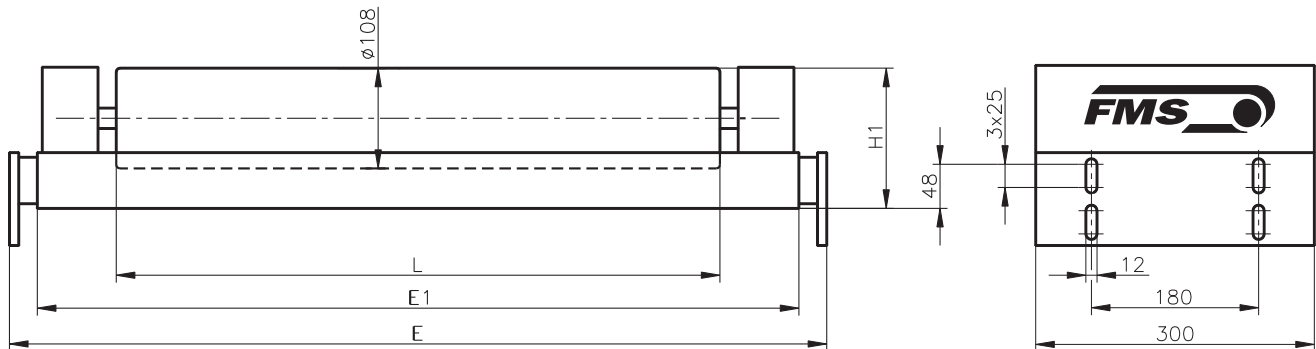

Dimensions (mm)

Width of belt	Type	l	e	e ₁	h ₁
400	BMGZ 021.020...*	400	600- 970	580	150
500	BMGZ 021.030...	500	700-1070	680	150
650	BMGZ 021.040...	650	850-1220	830	150
800	BMGZ 021.050...	800	1000-1370	980	150
1000	BMGZ 021.060...	1000	1200-1570	1180	150

*) Numbers for sizes of measuring bearings will be determined based on the application data.
Other designs on request.

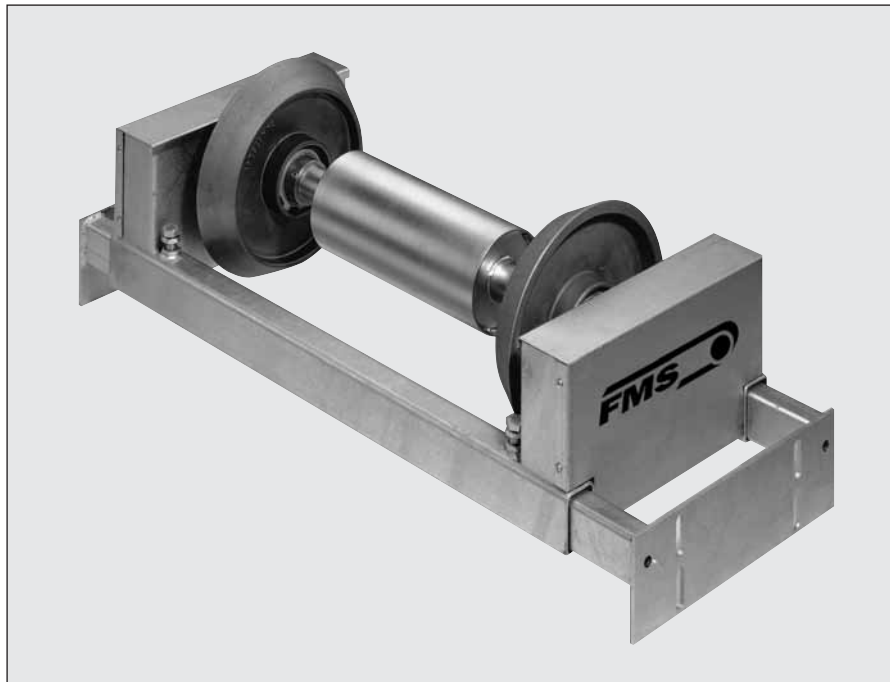

Troughed FMS Measuring Roller

The troughed FMS measuring roller is available for angles of inclination of 20° to 45°. Also the forces of the side parts of the belt are transmitted over conical slide disks separately supported on bearing exactly to the center shaft – and this way upon the force measuring bearings.

The conical slide disks are moveable on the shaft and can therefore be adapted to conveyors whose profile is not designed to a standard size.

All parts are galvanised, to provide a durable protection against rust.

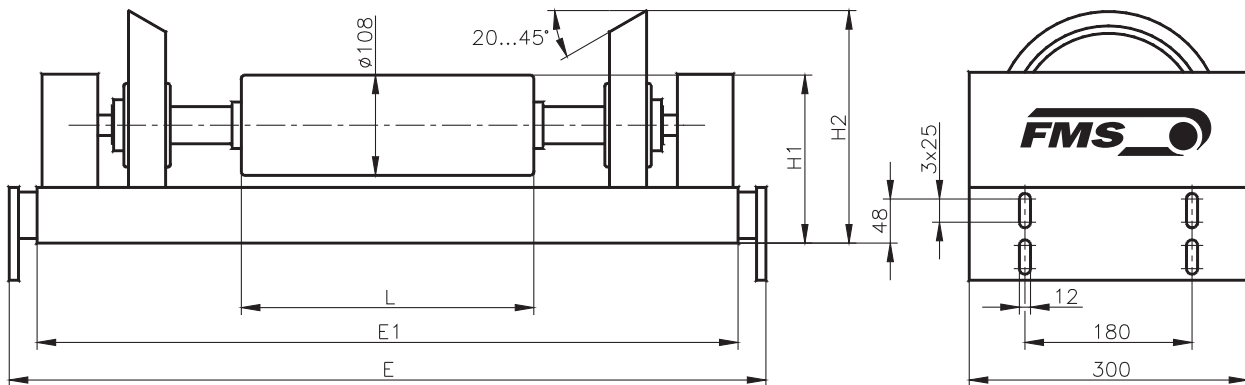

Dimensions (mm)

Width of belt	Type	l	e	e ₁	h ₁	h ₂
500	BMGZ 041.02...*	200	620- 990	600	180	232
650	BMGZ 041.03...	250	720-1090	700	180	250
800	BMGZ 041.04...	315	830-1200	810	180	250
1000	BMGZ 041.05...	380	1045-1415	1025	240	352
1200	BMGZ 041.06...	465	1180-1550	1160	240	352

*) Numbers for sizes of measuring bearings and angles of inclination will be determined based on the application data. Other designs on request.



BMGZ 610.W

Functional description

The versions BMGZ 610 / 611 provide evaluation of 1 measuring roller; while version BMGZ 620 provides evaluation of 2 measuring rollers. Versions BMGZ 611 provide additional digital inputs and outputs which can be used for extended control functions such as proportioning belt weighers, etc. All versions support an RS 232 interface as standard which may be used for remote controlling of all functions. For example a master computer (PC) or an external printer can be connected to the RS 232 interface. An additional board with PROFIBUS®-Bus interface is available as an option. Various mounting versions like wall or panel mounting or built in steel cabinet are available.

Functions

- Display of total amount conveyed [t]
- Display of daily amount [t]
- Display of momentary conveyor performance [t/h]
- Display of belt speed [m/s]
- Analog output proportional to conveyor performance
- Relay output for remote counter
- Printer output
- RS 232 interface or optional Profibus®

- **BMGZ 620 for connection to two measuring rollers**

**Functional Description
Taring / Calibration**

The BMGZ 600 Series electronic unit for belt scale bulk conveyors has an automatic tare program which is started by pressing a button. The tare program automatically calculates the tare value during two complete belt rotations. The calibration of the BMGZ 600 Series electronic unit is done by comparative weighing for example with a calibrated platform weigher. This reference value has to be set via the front keys into the BMGZ 600.

Measuring Principle

The BMGZ 600 Series electronic unit transforms and amplifies the measuring signals. The value is updated every 4 ms. The BMGZ 600 Series electronic unit subtracts the roller and the belt weight (tare) from the measuring value and multiplies the difference with the speed signal. The conveyor performance thus calculated is integrated and added to the current charge.



BMGZ 600 in cabinet

BMGZ 600 series electronic units can be supplied ready fitted in a steel cabinet (IP55).

Dimensions of cabinet for electronic unit:
400 x 400 x 275 mm (additional weight approx. 12 kg).

Order code for BMGZ 600 electronic units

Types of housing

The BMGZ 600 is available in the following versions:

- wall housing (aluminium housing in accordance with IP54)
- panel housing (aluminium housing for modular insertion with front IP 54 backside IP00)
- steel cabinet (dimensions 400 x 400 x 275 mm with IP 55)

BMGZ620.W.P.24V

Supply voltage:

unspecified = 230 VAC
24 V = 24 VDC

PROFIBUS® Interface:

unspecified = without PROFIBUS®
P = PROFIBUS®

Housings:

W = wall housing
S = panel housing
K = steel cabinet

Additional functions:

0 = standard version
1 = additional input and outputs for charge control and limit values

Number of measuring roller:

1 = single roller monitoring
2 = double roller monitoring

Features	BMGZ 610	BMGZ 611	BMGZ 620
Evaluation of 1 measuring roller	yes	yes	yes
Evaluation of 2 measuring rollers	–	–	yes
Min and Max limit relays	–	yes	–
Additional digital in- and outputs (galvanic insulated)	–	yes	–
Belt speed monitoring	yes	yes	yes
Operation	4 keys, LCD display 2 x 16 characters		
Display possibilities	total output conveyed [t], daily output resp. charge [t] actual flow rate [t/h], Belt speed [m/s]		
Daily output resp. charge counter	0...1000 t: Resolution 10 kg 1000...10000 t: Resolution 100 kg 10000...99999 t: Resolution 1000 kg		
Totalizator (Resolution 1000kg)	0...1 Mio t	0...1 Mio t	0...1 Mio t
Printer for charge protocol	external printer connected to RS232 (optional)		
Analogue output 1 (roller 1)	0...10 V,0 / 4...20 mA free scalable, 12 bit		
Analogue output 2 (roller 2)	–	–	0...10 V,0 / 4...20 mA free scalable, 12 bit
Analogue output 3 (roller 1)	–	–	–
Relay-driven pulse output (for ex. for telecounter)	contact bond strength 24 VDC / 1 A pulse length 100 ms		
Interface RS232	yes	yes	yes
Interface PROFIBUS®	optional	optional	optional
Measuring bearing connection	350 Ω force measuring bearings		
Measuring bearing excitation	5 VDC	5 VDC	5 VDC
Measuring bearing signal	0...9 mV (max. 12.5 mV)	0...9 mV (max. 12.5 mV)	0...9 mV (max. 12.5 mV)
Cycle time	4 ms	4 ms	4 ms
Power consumption	5 W	5 W	5 W
Temperature range	-10...+45 °C	-10...+45 °C	-10...+45 °C
Weight	1.5 kg	1.5 kg	1.5 kg
Power supply	24 VDC or 230 VAC	24 VDC or 230 VAC	24 VDC or 230 VAC

Mounting of the measuring roller

FMS belt scales have an adjustable support as standard. The width can thus be adjusted within a range of 370 mm.

Furthermore two universal brackets for installation, with which the position of the measuring roller can be adjusted in height, are delivered as parts of the measuring roller.

Especially for installation in existing conveyors where no mounting console for the belt scale is existing, the installation work – and thus the expense – is reduced to a minimum thanks to the user friendly design.

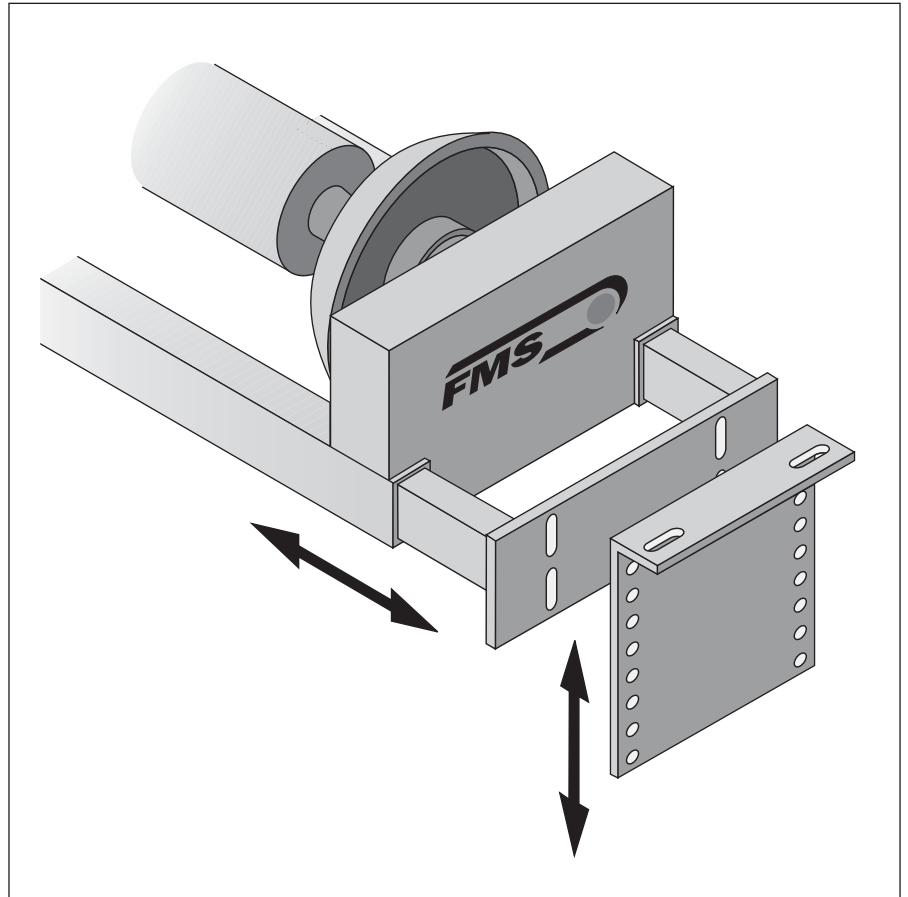

Dimension of mounting brackets

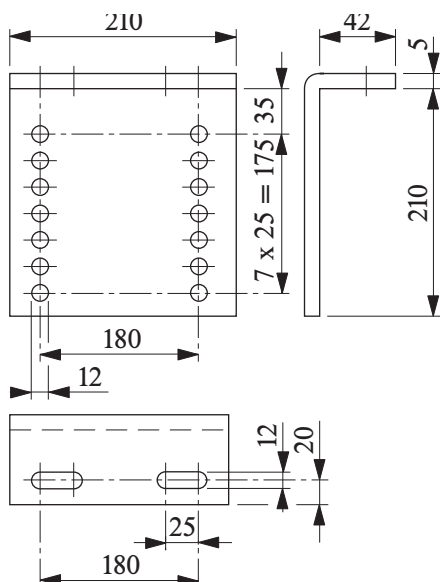

In order to guarantee a perfect performance with the minimal possible error, attention must be paid to the layout of the bulk conveyor regarding the following points:

- The tension of the belt must remain constant
- The inclination of the belt shall be only so great that no relative motion of the material to be conveyed occurs
- The flowrate shall be in a range of 20...100% of the nominal capacity
- The belt scale shall be mounted so far from loading of bulk that the material becomes stabilized again
- The belt scale shall stay as far as possible from the drive roller
- The belt scale shall have its place only on a straight forward rectilinear piece of the belt

FMS Belt Scales for Bulk Conveyors

Data required for tenders

FMS Force Measuring Systems AG
Aspstrasse 6 8154 Oberglatt (Switzerland)

Tel. ++41 1 852 80 80 Fax ++41 1 850 60 06
info@fms-technology.com www.fms-technology.com

In order to work out a quotation for a belt scale for bulk conveyors, FMS takes into consideration all the requirements of the user. FMS needs therefore this sheet filled out as completely as possible

Customer _____
 Project no/name _____
 Bulk material _____
 Contact _____ Date _____

Data for layout of measuring roller

Maximum flowrate	Q	=	_____	[t/h]
Belt speed	v	=	_____	[m/s]
Distance between the supporting roller stations	a	=	_____	[mm]
Weight of the belt per m ²	m _G	=	_____	[kg]
- or kind of belt (type, design)		=	_____	
Width of belt	b	=	_____	[mm]
Trough angle (0° for flat belt)	λ	=	_____	[Grad]
Width of center part	l ₃	=	_____	[mm]
Inclination of the belt	φ	=	_____	[Grad]
Admissible measuring error		=	± _____	[%]
Length of cable roller/electronic unit		=	_____	[m]

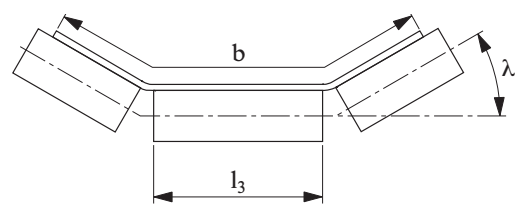
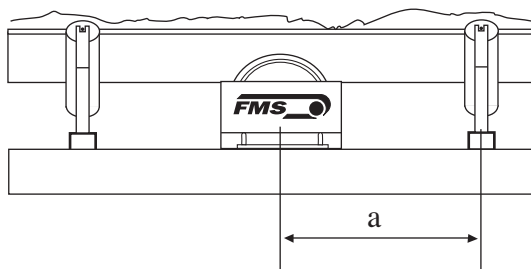

Data desired for electronic unit

Supply voltage	110-230 VAC	<input type="checkbox"/>	Printer	<input type="checkbox"/>
	24 VDC	<input type="checkbox"/>	Analog instrument	<input type="checkbox"/>
Wall mounted housing (W)		<input type="checkbox"/>	Remote counter	<input type="checkbox"/>
Panel housing (S)		<input type="checkbox"/>	Limit switches	<input type="checkbox"/>
Steel cabinet (K)		<input type="checkbox"/>	Analog output	<input type="checkbox"/>
19" OEM		<input type="checkbox"/>	Charge preselection	<input type="checkbox"/>
			Profibus® connection	<input type="checkbox"/>

Remarks _____



Hand printer
For printout of charge and totalizer values.



Remote counter
To display the charge value. The remote counter can be installed up to about 400 m away from the Scale Processor. Reset of the remote counter is possible at the remote counter itself. Optional built in a housing.



Analog instrument
To display the flowrate in tons per hour. According to standards up to 100, 500 and 1200 t/h. Optional built in a housing.



World Headquarters:
FMS Force Measuring Systems AG
Aspstrasse 6
8154 Oberglatt (Switzerland)
Phone + 41 44 852 80 80
Fax + 41 44 850 60 06
info@fms-technology.com

FMS USA, Inc.
2155 Stonington Avenue
Suite 119
Hoffman Estates, IL 60169
Phone + 1 847 519 4400
Fax + 1 847 519 4401
fmsusa@fms-technology.com

FMS UK
Highfield, Atch Lench Road
Church Lench
Evesham WR 11 4UG
Phone + 44 1386 871023
Fax + 44 1386 871021
fmsuk@fms-technology.com

FMS Italy
Via Baranzate 67
20026 Novate Milanese
Phone + 39 02 39487035
Fax + 39 02 39487035
fmsit@fms-technology.com