

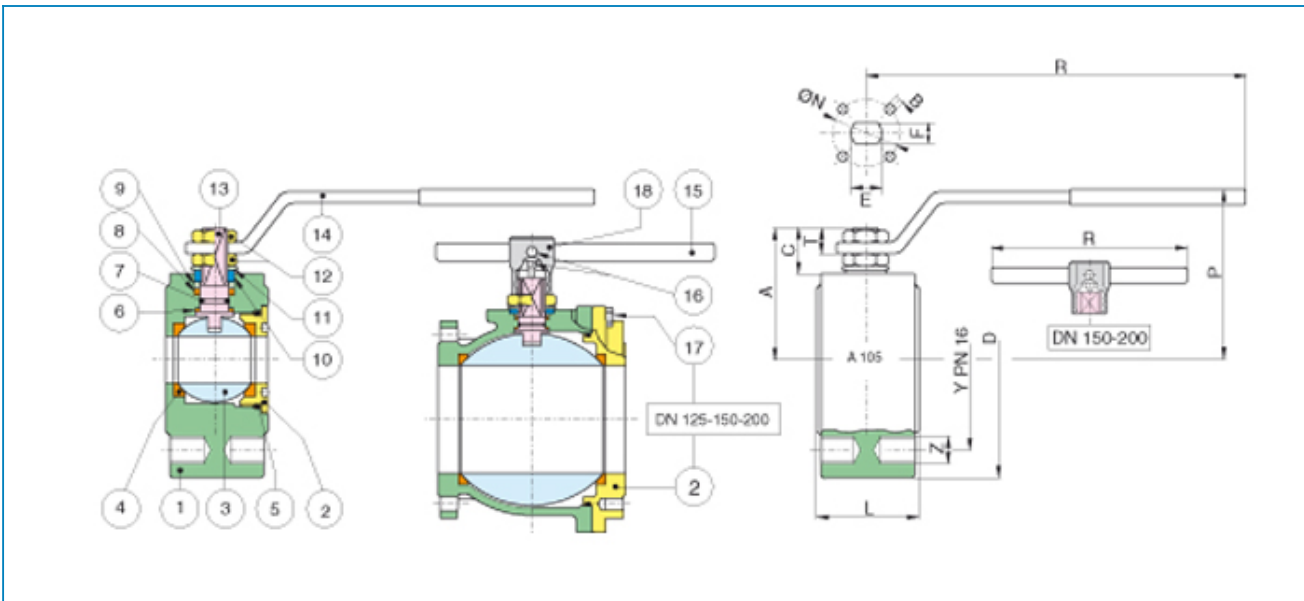

Serie **WAFER PN16.**

Articolo **720001**

Full bore flanged ball valve PN 16, in carbon steel ASTM A105.



Limiti di temperatura: -10° +160° - Temperature range: -10° +160° Vuoto: 10-3 torr. - Vacuum: 10-3 torr.

POS.	PART NAME	MATERIALE-MATERIALS MATERIAUX-WERKSTOFF- MATERIAL	N°P
1	BODY	ASTM A105 / A216-WCB	1
2	END CONNECTION	ASTM A105 / A216-WCB	1
3	BALL	CW 617 UNI EN 12165	1
4	BALL SEAT	P.T.F.E.	2
5	O-RING	FKM (VITON®)	1
6	THRUST WASHER	P.T.F.E.	1
7	RING	FKM (VITON®)	1
8	STEM SEAT	P.T.F.E.	1
9	PACKING GLAND	CARBON STEEL	1
10	END STOP	INOX AISI 430 (DN15 - DN50) CARBON STEEL DN65 - DN150)	2-1
11	SPRING WASHER	CARBON STEEL	2
12	NUT	CARBON STEEL	2
13	STEM	A182 - F304	1
14	HANDLE	CARBON STEEL	1
15	HANDLE DN 150-200	CARBON STEEL	1
16	SCREW	CARBON STEEL	1
17	SCREW	CARBON STEEL	8-12
18	BODY HANDLE DN 150-200	EN-GJL-250	1

MISURA SIZE	DN	D	Y	Z	L	R	P	A	C	T	E	F	ØN	B	Kv	PN	Kg
1/2"	15	90	65	4 x M12	35	131	65	47	15,5	9	10	7	32	4 X M5	16,3	16	1,30
3/4"	20	100	75	4 x M12	40	131	69	51,5	15,5	9	10	7	32	4 X M5	29,5	16	1,90
1"	25	110	85	4 x M12	46	174	80	61	19,5	11	12	8	42	4 X M5	43	16	2,70
1"1/4	32	130	100	4 x M16	54	174	84	65,5	16,5	11	12	8	42	4 X M5	89	16	4,20
1"1/2	40	140	110	4 x M16	63,5	250	102	78	24,5	13	16	10	50	4 XM6	230	16	5,90
2"	50	150	125	4 X M16	82	250	111	87	25	13	16	10	50	4 XM6	265	16	8,70
2"1/2	65	175	145	4 X M16	103	321	128	104,5	28	18	20	14	70	4 X M8	540	16	15,50
3"	80	190	160	8 X M16	122	321	138	115	28,5	18	20	14	70	4 X M8	873	16	20,50
4"	100	220	180	8 X M16	152	381	156	137	34,5	22	24	18	102	4 X M10	1390	16	34,20
5"	125	250	210	8 X M16	196	381	178	159	34	22	24	18	102	4 X M10	1707	16	52,50
6"	150	300	240	8 X M20	232	700	266	201,5	51,5	30	42	30	125	4 X M12	2024	16	61,80
8"	200	340	295	12 x Ø22	400	700	332	288	68	28	42	30	125	4 X M12	2720	16	104,00