



Serie **WAFER PN16.**

Articolo **720302**

CARBON STEEL

Full bore flanged ball valve PN16 Antistatic Device.

PER VAPORE-FOR STEAM

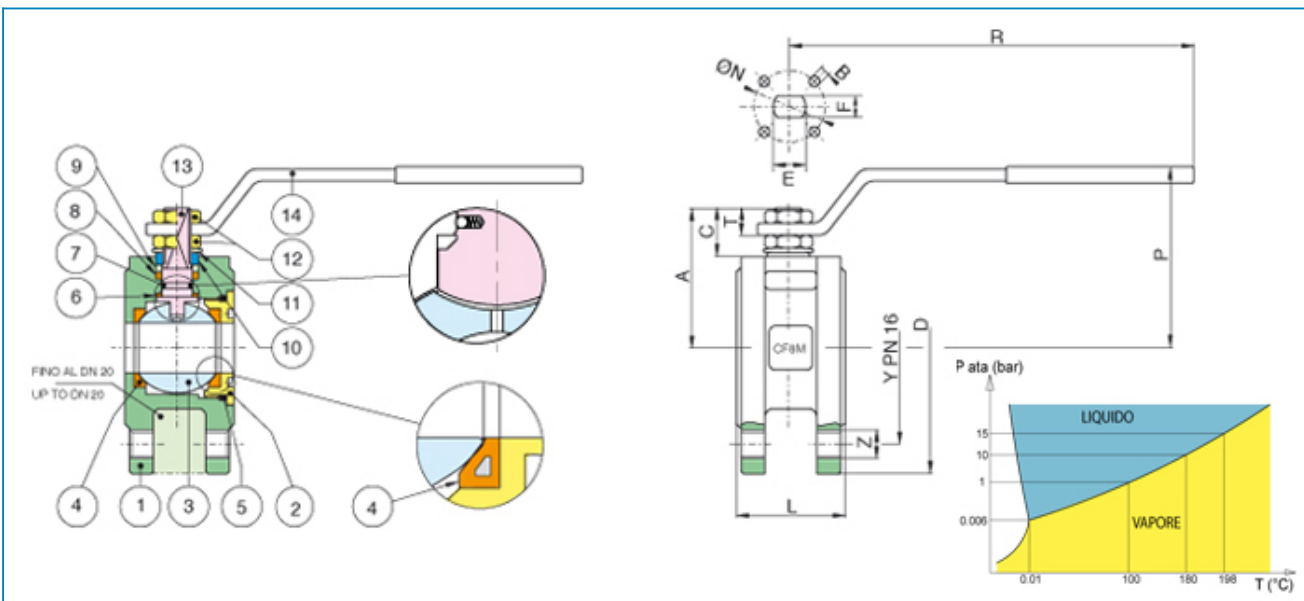

POS.	PART NAME	MATERIALE-MATERIALS MATERIAUX-WERKSTOFF- MATERIAL	N°P
1	BODY	ASTM A105	1
2	END CONNECTION	ASTM A105	1
3	BALL	A351-CF8/ A182-F304	1
4	BALL SEAT	P.T.F.E.+METAL	2
5	O-RING	EPDM	1
6	THRUST WASHER	P.T.F.E.+CARBOGRAFITE	1
7	O-RING	EPDM	1
8	STEM SEAT	P.T.F.E.+CARBOGRAFITE	1
9	PACKING GLAND	CARBON STEEL	1
10	END STOP	INOX AISI 430 (DN15 - DN50) CARBON STEEL (DN65 - DN100)	2-1
11	SPRING WASHER	CARBON STEEL	2
12	NUT	CARBON STEEL	2
13	STEM	A182 - F316	1
14	HANDLE	CARBON STEEL	1

MISURA SIZE	DN	D	Y	Z	L	R	P	A	C	T	E	F	ØN	B	Kv	PN	Kg
1/2"	15	90	65	4 X M12	35	131	65	47	15,5	9	10	7	32	4 X M5	16,3	16	1,30
3/4"	20	100	75	4 X M12	40	131	69	51,5	15,5	9	10	7	32	4 X M5	29,5	16	1,90
1"	25	115	85	4 X M12	46	174	80	61	17	11	12	8	42	4 X M5	43	16	2,70
1"1/4	32	140	100	4 X M16	54	174	84	64,5	15	11	12	8	42	4 X M5	89	16	4,20
1"1/2	40	150	110	4 X M16	63,5	250	102	78	24,5	13	16	10	50	4 X M6	230	16	5,90
2"	50	165	125	4 X M16	82	250	111	87	25	13	16	10	50	4 X M6	265	16	8,70
2"1/2	65	185	145	4 X M16	103	321	128	104,5	25	18	20	14	70	4 X M8	540	16	15,50
3"	80	200	160	8 X M16	122	321	138	115	28,5	18	20	14	70	4 X M8	873	16	20,50
4"	100	220	180	8 X M16	152	381	156	137	34,5	22	24	18	102	4 X M10	1390	16	34,20

PRESSIONE VAPORE bar STEM PRESSURE IN bar	1	2	3	4	5	6	7	8	9	10
TEMPERATURA VAPORE C° STEM TEMPERATURE IN C°	100	120	133	143	152	158	165	170	175	180