



Serie **SPLIT-BODY PN16...**

Articolo **760802**

**CARBON STEEL**

Flanged PN16 stainless steel AISI 316-CF8M and carbon steel WCB ball valve, full bore, EN 558 basic series 1 face to face dimension, Fire Safe, Antistatic Device.

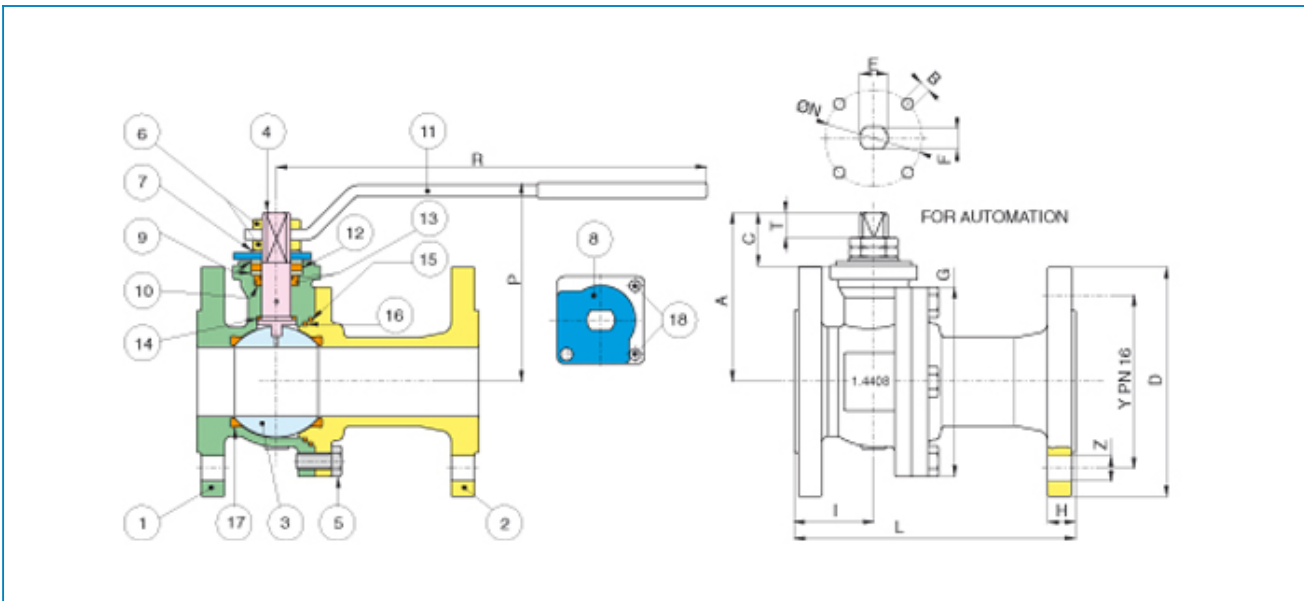

Limiti di temperatura: -10° +160° - Temperature range: -10° +160° Vuoto: 10-3 torr. - Vacuum: 10-3 torr.

POS.	PART NAME	MATERIALE-MATERIALS MATERIAUX-WERKSTOFF- MATERIAL	N°P
1	BODY	1.0619	1
2	END CONNECTION	1.0619	1
3	BALL	A182-F304 / A351-CF8	1
4	STEM	A182-F304	1
5	SCREW	CARBON STEEL DN15 - DN40 CARBON STEEL DN50 - DN100	4-8
6	NUT	CARBON STEEL	2
7	SPRING WASHER	CARBON STEEL	2
8	90° STOP	CARBON STEEL	1
9	PACKING GLAND	A182-F316	2
10	STEM SEAT	P.T.F.E.	1
11	HANDLE	CARBON STEEL	1
12	STEM SEAL	GRAPHOIL	1
13	O-RING	FKM (VITON®)	2
14	THRUST WASHER	P.T.F.E.	1
15	BODY SEAT	GRAPHOIL	1
16	BODY SEAT	P.T.F.E.	1
17	BALL SEAT	P.T.F.E.	2
18	SCREW	CARBON STEEL	2

MISURA SIZE	DN	D	Y	Z	H	I	L	G	P	R	A	C	T	E	F	ØN	B	Kv	PN	Kg
1/2"	15	95	65	4 X Ø14	16	49	130	71	88	131	52	19	8	M10	7	42-F04	M5	16,3	40	3,00
3/4"	20	105	75	4 X Ø14	18	51,5	150	73,5	93	131	56	19	8	M10	7	42-F04	M5	29,5	40	3,50
1"	25	115	85	4 X Ø14	18	53	160	90,5	89	174	72,5	27,5	13	M12	8	50-F05	M6	43	40	4,00
1"1/4	32	140	100	4 X Ø18	18	55	180	97	112	174	76	27,5	13	M12	8	50-F05	M6	89	40	6,10
1"1/2	40	150	110	4 X Ø18	18	51,5	200	114	133	250	107	30	10	M16	10	50-F05	M6	230	40	10,00
2"	50	165	125	4 X Ø18	20	57,5	230	136,5	144	321	122	38,5	18	M20	14	70-F07	M8	265	40	12,50
2"1/2	65	185	145	4 X Ø18	18	61	290	167,6	154	321	133	39,5	18	M20	14	70-F07	M8	540	16	15,00
3"	80	200	160	8 X Ø18	20	75,5	310	178,6	173	381	151	43	18	M24	18	102-F10	M10	873	16	23,00
4"	100	220	180	8 X Ø18	20	80	350	208,6	187	381	165	43	18	M24	18	102-F10	M10	1390	16	31,00