

Serie **COMBI-SFER.**

Articolo **776000 L - 776001 T**

**CARBON STEEL**

Three way flanged PN16 diverter ball valve, "L" and "T" port, with two seats, reduced port.

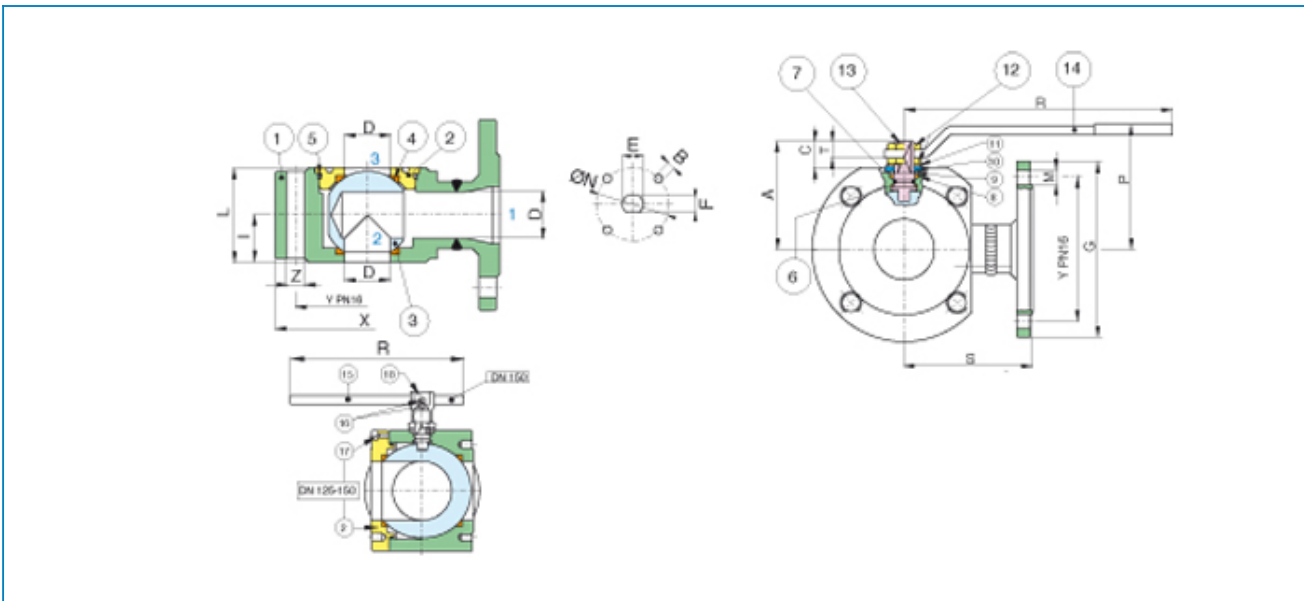

Limiti di temperatura: -10° +160° - Temperature range: -10° +160° Vuoto: 10-3 torr. - Vacuum: 10-3 torr.

POS.	PART NAME	MATERIALE - MATERIALS - MATERIAUX - WERKSTOFF - MATERIAL	N°P
1	BODY	ASTM A105	1
2	END CONNECTION	ASTM A105	1
3	BALL	A351-CF8M	1
4	BALL SEAT	P.T.F.E.	2
5	O-RING	FKM (VITON®)	1
6	THRUST WASHER	P.T.F.E.	1
7	O-RING	FKM (VITON®)	1
8	STEM SEAT	P.T.F.E.	1
9	PACKING GLAND	CARBON STEEL	1
10	END STOP	INOX AISI 430 DN 15- DN 5 CARBON STEEL DN 65 - DN 100	2 1
11	SPRING WASHER	CARBON STEEL	2
12	NUT	CARBON STEEL	2
13	STEM	A182-F304	1
14	HANDLE	CARBON STEEL	1
15	HANDLE DN 150	CARBON STEEL	1
16	SCREW	CARBON STEEL	1
17	SCREW	CARBON STEEL	8
18	BODY HANDLE DN150	EN-GJL 250	1

MISURA SIZE	DN	X	Y	Z	I	L	R	P	A	C	T	G	M	D	S	E	F	ØN	B	PN	Kg
1/2"	15	89	65	4 X M12	20	40	131,5	64,5	47	15,5	9	95	4 X Ø14	10	76	10	7	32	4 X M5	16	2,23
3/4"	20	99	75	4 X M12	20	40	131,5	67	49,5	13,5	9	105	4 X Ø14	15	82	10	7	32	4 X M5	16	2,86
1"	25	109	85	4 X M12	23	46	174,5	79	59	18	12,5	115	4 X Ø14	20	86	12	8	42	4 X M5	16	3,89
1"1/4	32	130	100	4 X M16	29	58	250,5	84	64	15,5	11,5	140	4 X Ø18	25	105	12	8	42	4 X M5	16	6,21
1"1/2	40	140	110	4 X M16	35,5	71	250,5	102,5	78	24,5	13	150	4 X Ø18	32	110	16	10	50	4 X M6	16	8,50
2"	50	160	125	4 X M16	41	82	321,5	109	85	25	13,5	165	4 X Ø18	40	115	16	10	50	4 X M6	16	12,27
2"1/2	65	180	145	4 X M16	53	106	321,5	128	104,5	28	18	185	4 X Ø18	50,2	125	20	14	70	4 X M8	16	19,10
3"	80	200	160	8 X M16	61	122	381,5	136,5	113	28	18	200	8 X Ø18	64	150	20	14	70	4 X M8	16	24,34
4"	100	220	180	8 X M16	76	152	381,5	155,5	136	34,5	22	220	8 X Ø18	76	159	24	18	102	4 X M10	16	38,45
5"	125	250	210	8 X M16	98	196	381,5	178,5	159	34,5	22	250	8 X Ø18	100	190	24	18	102	4 X M10	16	63,00
6"	150	306	240	8 X M20	116	242	700	252	201	59	29	285	8 X Ø22	125	210	42	30	125	4 X M12	16	108,00