

SMALL SIZE FLOW CONTROLLER FCM SERIES



SMALL SIZE FLOW CONTROLLER RAPIFLOW® FCM SERIES



FLOW CONTROLLER FCM (RAPIFLOW) SERIES

Neu!

Kleiner Durchfluss Regler

Kleines und leichtes Design (30*70*70mm, 200g)

Präzise und schnelle Ansprechzeit (0.5sec)

Geeignet für verschiedene Gas Klassen (AIR, N2, Ar, O2, CH4, C3H8)

Viele Funktionen erhältlich (integrating function, auto-shut-off-safety)

Äusserst zuverlässiger Durchfluss Regler (repeatability $\pm 1\%$ FS, accuracy $\pm 3\%$ FS)

Small flow controller

Miniature /light weight (30*70*70mm, 200g)

High speed response (0.5sec)

For various gas classes (AIR, N2, Ar, O2, CH4, C3H8)

Various functions available (integrating function, auto-shut-off-safety)

High reliable flow control (repeatability $\pm 1\%$ FS, accuracy $\pm 3\%$ FS)

COMPARISON WITH CONVENTIONAL PARTS

VOLUME IS 30% OF
CONVENTIONAL
PARTS

WEIGHT IS 20% OF
CONVENTIONAL
PARTS



Compact, high-speed, multifunction solution

Reach high accuracy and multifunction with microcomputers

High-speed-response micro processing sensor chip



Stainless steel body

Applicable fluids/Flow rates

AIR **N₂**
0.015~50 l/min

Ar
0.015~50 l/min

O₂ **13A** **CH₄** **C₃H₈**
0.015~10 l/min

Weight: 480 g

Rectifying ensures low-pressure loss and realizes repeatability

Resin body

Applicable fluids/Flow rates

AIR **N₂**
0.015~100 l/min

Weight: 200 g

Ultimate ideal multi-functions flow controller

Small size flow controller

FCM Series

Compact Flow Controller FCM Series
Combining compact flow rate sensor FCM and compact solenoid valve technology.
High performance and cost efficient sensing, proportional control, and valve functions, this will match customer's needs.



New Low differential pressure model

The flow rate of combustion gas with low supply pressure is controlled, such as for controlling burner flame.

Compact and lightweight

Just 70_70_30mm (H_D_W), this controller is installed in small spaces or movable sections, enabling equipment to be downsized and lightened.

Volume
30% compared to conventional model
Weight
20% compared to conventional model



0.5 s high-speed control

The platinum sensor chip with silicon micromachining is capable of 0.5 s high-speed control. This controller is used for different applications.

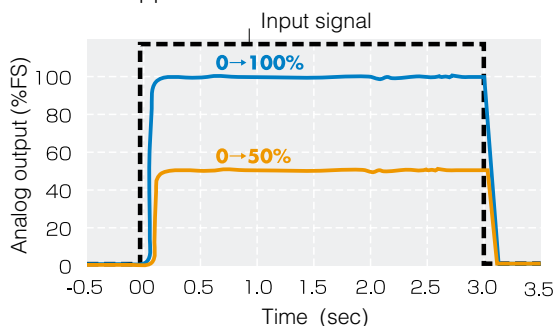

Dedicated power not necessary

This controller uses a 24V DC power supply, and is operated with a general-purpose single power supply.

Highly reliable flow control

CKD's original rectifying mechanism improves repeatability affecting flow control.

Repeatability $\pm 1\%$ FS
Accuracy $\pm 3\%$ FS

Compatible with different fluids

This controller is used with air, nitrogen, and gases such as argon, oxygen, methane, butane, and propane, enabling use with different applications.

RoHS Directive-compliant **RoHS**

All substances, such as lead and hexavalent chrome, that could adversely affect the global environment have been eliminated from materials used in this controller.

FCM Series INDEX

Specifications 1

Dimensions 4

Explanation of functions 8

Operation method 9

Digital display for easy confirmation of control

- The flow rate is shown on a 3-digit display.
- Errors and the output state (switch output ON-OFF) are displayed.

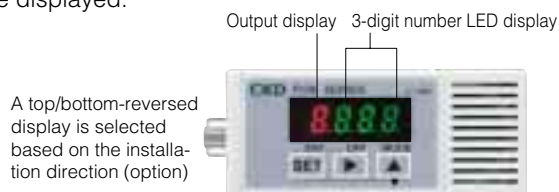

Parallel input is standard

Control is possible with parallel input PLC, etc., ON/OFF signal, 10-bit resolution 1024. Analog input/output devices, such as D/A converters, are not required.



Realize multi-functions with microcomputer

Error display

Error occurrence is indicated with displays and electric signals.

Zero span adjustment

The input signal's zero span is adjusted based on the application.

Preset input

When four random flow rate points are set, the flow rate is controlled by inputting a 2-bit signal from an external source (signals from PLC, etc.).

Direct memory

Even without input signals from an external source, control flow rate is freely adjusted with the product's operation keys.

Switch output

A switch output using flow rate upper/lower limit settings is incorporated. Integrated overcurrent protection.

Flow rate integrator function

A flow rate integration display (6 digits maximum) and integrating pulse output are possible.

Automatic shutoff

If an emergency, such as an error occurs, the valve is automatically shut off.

Examples of applications

Useful in different fields

This small size flow controller is used for different applications including machinery, automobile, and precision device fields, advanced fields such as semiconductors and biotechnology, medicine and food.

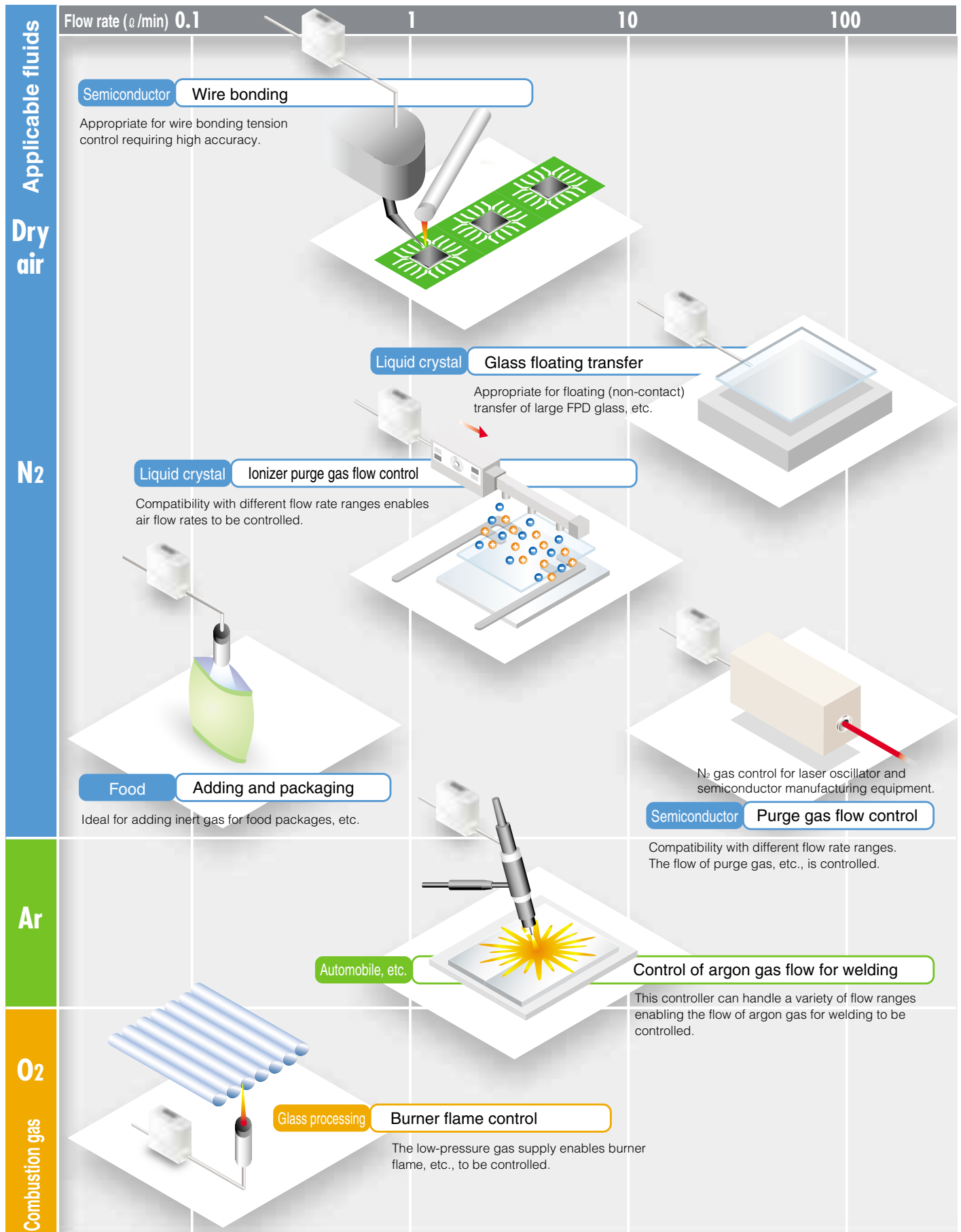

FCM Series

Applicable fluids and flow control ranges

Model No.	Applicable fluids	Flow rate control range (ℓ/min)					Body material	Port size
		0.01	0.1	1	10	100		
FCM-9500 AI	Air Nitrogen					0.015 to 0.5	Resin	Resin ø6 push in ø8 push in
FCM-0001 AI						0.03 to 1		
FCM-0002 AI						0.06 to 2	SUS	SUS Rc1/4 9/16-18 UNF
FCM-0005 AI						0.15 to 5		
FCM-0010 AI						0.3 to 10		
FCM-0020 AI						0.6 to 20		
FCM-0050 AI						1.5 to 50		
FCM-0100 AI (only resin type)						3 to 100		
FCM-9500 AR	Argon					0.015 to 0.5	SUS	Rc1/4 9/16-18 UNF
FCM-0001 AR						0.03 to 1		
FCM-0002 AR						0.06 to 2		
FCM-0005 AR						0.15 to 5		
FCM-0010 AR						0.3 to 10		
FCM-0020 AR						0.6 to 20		
FCM-0050 AR						1.5 to 50		
FCM-9500 O2/LN/C1/C3	Oxygen City gas Methane Propane					0.015 to 0.5	SUS	Rc1/4 9/16-18 UNF
FCM-0001 O2/LN/C1/C3						0.03 to 1		
FCM-0002 O2/LN/C1/C3						0.06 to 2		
FCM-0005 O2/LN/C1/C3						0.15 to 5		
FCM-0010 O2/LN/C1/C3						0.3 to 10		

Input/output specifications

Input	Model No.	Output		
		Output type	Specifications	Error output
Analog: 0 to 10 V Pre-set: 4 points (2bit) (Note)	FCM-*-0AN	Analog	1 to 5 V	NPN
	FCM-*-0AP			PNP
	FCM-*-0SN	Switch	NPN	NPN
				FCM-*-0SP
Analog: 0 to 5 V Pre-set: 4 points (2bit) (Note)	FCM-*-1AN	Analog	1 to 5 V	NPN
	FCM-*-1AP			PNP
	FCM-*-1SN	Switch	NPN	NPN
				FCM-*-1SP
Analog: 4 to 20 mA Pre-set: 4 points (2bit) (Note)	FCM-*-2AN	Analog	1 to 5 V	NPN
	FCM-*-2AP			PNP
	FCM-*-2SN	Switch	NPN	NPN
				FCM-*-2SP
Parallel: 10bit	FCM-*-PAN	Analog	1 to 5 V	NPN
	FCM-*-PAP			PNP
	FCM-*-PSN	Switch	NPN	NPN
				FCM-*-PSP

Note: Preset 8-point (3-bit) input is used customized. The external integration reset signal input cannot be used. Contact your CKD Sales Office for details.



Flow controller

Safety Precautions

Always read before starting use

Small size flow controller FCM series

Design & Selection

1. Working fluid

DANGER

- Do not feed gas at the explosion limit. There is a risk of explosion.
- Do not feed oxygen gas to wetted sections that are not oil-prohibited. There is a risk of fire. Even if the product has oil prohibited, if gas other than oxygen gas has passed even once, do not use the product for oxygen gas.

WARNING

- This product cannot be used as a business meter. This product does not comply with Measurement Laws, and cannot be used for commercial business.
- Do not use any fluids not specified because accuracy and controllability, etc., cannot be satisfied.
- Prevent entry of foreign matter into this product. If foreign matter gets into this product (dirt, water, or oil mist into pipes), accuracy and controllability could drop or the product could fail. If foreign matter could enter the product, install a filter, dryer, or oil mist filter upstream from the product.
 - The mesh provided in this product is used to rectify the flow in pipes. It is not a filter for removing foreign matter.
 - Compressed air from the compressor contains drainage (water, oxidized oil, foreign matter, etc.), so install a filter, air dryer, and oil mist filter (microalescer) upstream from the product.

<Recommended circuit >

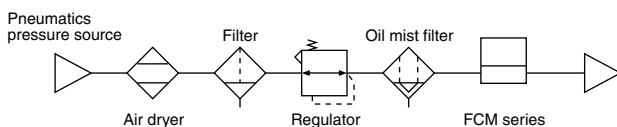

- When using a valve on the primary side of this product, only use an oil-prohibit specification valve. This controller could malfunction or fail if subject to splattering grease or oil, etc.
- When using this controller for liquified gas such as propane gas, evaporate the gas. This controller could fail if liquified gas is fed.
- When using this product to control burner air-fuel ratio, take measures in the design stages to prevent backfire, and to prevent adverse effect to this product even if a backfire should occur. A rise in the pipe's internal pressure and flame caused by a burner's backfire could damage this product.

2. Working environment

WARNING

- Corrosive environment
Do not use this product in an environment containing corrosive gases such as sulfurous acid.
- Ambient temperature, fluid temperature
Keep the ambient temperature and fluid temperature within 0 to 50°C.
Even if the temperature is within the specified range, do not use this product if the ambient temperature and fluid temperature could suddenly change and cause dew to condense.
- Guaranteed withstanding pressure and operating pressure difference range.
Using this product at a level exceeding the guaranteed withstanding pressure and operating pressure difference could cause damage. Follow the specified range.
- Drip-proof environment
This product's protective structure is IP40 or equivalent. Do not install it where it could be subject to water, salt, dust, or cutting chips, or a compressed or decompressed environment. This product cannot be used where the temperature changes sharply or in a highly humid environment as dew condensation in the product could cause damage.
- This product's solenoid proportional valve does not have a complete close-stop.
If a complete close-stop is required, provide a separate external shutoff valve.
When the external shutoff valve is closed, wait with this product's valve fully closed (set flow rate: zero). If this product is left in normal control while this external shutoff valve is closed, an instant overflow could occur when the external shutoff valve is opened.
When using for applications that turn ON/OFF at a high frequency, the life of the proportional valve may be shortened depending on use. Contact CKD when using for applications that turn ON/OFF at a high frequency.

- Do not install this product at a place that moves or vibrates. Vibration or impact could cause this controller to malfunction.

CAUTION

- Check the leakage current to prevent malfunction caused by current leaking from other controllers.
When using a programmable controller, etc., the leakage current could cause this product to malfunction.
- Due to wiring, the current input power ground and signal common are the same.
When driving several of these products with one PLC and D/A unit, depending on the D/A unit's circuit, the correct signal may not be input because of wiring problems. Consult with the PLC maker before using.



Flow controller

Safety Precautions

Always read before starting use

Small flow controller FCM series

Design & Selection

2. Working environment

⚠ CAUTION

- Current input is used with input signal 1-5 V, but unlike other voltage input, the input impedance is small at 250 Ω , so a signal generator that matches this impedance must be used.
- Monitor the pipe's pressure loss
When piping this product, check that the differential pressure between the upstream side and downstream side is within the operating pressure difference range (refer to page 2). Controller may not operate properly if used outside of the operating pressure difference range.

3. Flow unit

⚠ CAUTION

- This controller's flow rate is measured with mass flow not affected by pressure. The unit is l/min , that is the mass flow converted to volumetric flow at 20°C 1 barometric pressure (101 kPa).

Installation & Adjustment

1. Wiring

⚠ DANGER

- Use the power voltage and output within the specified voltage. If a voltage exceeding the specified voltage is applied, the product could malfunction, be damaged, or electric shock or fires could occur. Do not use loads that exceed the output rating. The output could be damaged or fires could start.

⚠ WARNING

- Check the connector pin and cable core wire color when wiring. Incorrect connections could result in sensor damage, problems, and malfunctions, so check the wire color against the instruction manual before wiring.
- Check wiring insulation.
Check that wires do not contact other circuits, that there is no ground fault, and that the insulator between terminals is not defective. An overload could flow to the product, and result in damage.
- Use a DC stabilized power supply, within the specified rating, insulated from the AC power supply. Failure to insulate the power supply could result in electric shock. If power is not stabilized, the peak could be exceeded during the summer. This could damage this product or cause accuracy to drop.
- Stop controller and devices, and turn power OFF before wiring. Starting operation suddenly could result in unpredictable operation and hazards. Conduct an energized test with controllers and devices stopped, and set target switch data. Discharge any static electricity accumulated by personnel or tools before and during work. Connect and wire bending

resistant material, such as robot wire material, for movable sections.

- Do not use this controller at levels exceeding the power voltage range. If voltage exceeding the specified range is applied, or if an AC power (100V AC) is applied, the controller could break or burn.
- Separate this product and its wiring as far away from sources of noise such as power distribution wires. Provide separate measures for surge applied to the power cable.
- Do not short-circuit the load. This product could break or burn.
- Use stabilized DC power completely separated from the AC primary side for stainless steel construction. Connect either the plus or minus side of the power supply to the FG. A varistor (limit voltage. 40 V) is connected between the stainless steel internal power circuit and stainless steel device to prevent dielectric breakdown of the sensor. Do not conduct a withstand voltage test or insulation resistance test between the internal power circuit and stainless steel device. Disconnect wiring if this testing is required. An excessive potential difference between the power and stainless steel device will cause the internal parts to burn.
After installing, connecting, and wiring the stainless steel device, electrical welding of the device or frame or short-circuit accidents, etc., could cause the welding current, the excessive high voltage caused by welding, or a surge voltage, etc., to run through wiring or ground wire connected between the above devices. This could result in damage to wires or devices. Conduct any work such as electrical welding after removing this device and disconnecting all electric wires connected to the FG.

Installation & Adjustment

1. Wiring

⚠ CAUTION

- The option shield cable connector is a shielded wire. Insulate wires that are not being used so that they do not contact other wires, including shielded wires. If inadvertently connected to the ground, etc., the controller could malfunction or break.
- Securely insert the D-sub connector into the back.
- Lock the D-sub connector so that it does not dislocate. Before loosening the lock, fix the fixing block with a tool, etc.

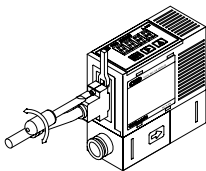

2. Piping

⚠ CAUTION

- Pipe based on the fluid direction and the direction indicated on the device.
- Before piping, clean pipes with compressed air to remove any foreign matter of cutting chips, etc. The rectifying unit or platinum sensor could be damaged if foreign matter or cutting chips get in.
- When attaching piping to this product, use the following torques as reference so that excessive screwing torque or load torque is not applied to the connection port.

Set screw	Tightening torque N·m
Rc1/4	6-8
9/16-18UNF	6-8

- When piping, put a wrench, etc., on the stainless steel device so that force is not applied to the resin section.

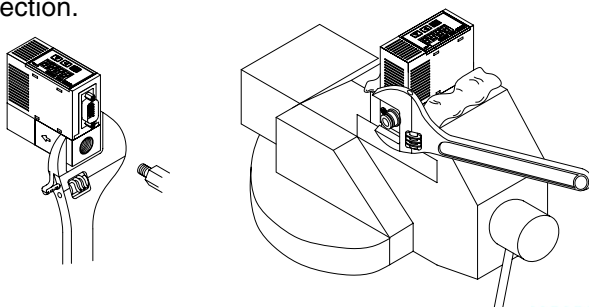

- Check that sealing tape or adhesive does not get inside when piping.

When winding fluorine resin sealing tape around threads, wind the sealing tape one to two times, leaving two to three threads open at the end of the screw. Press down on the tape to stick it onto threads. When using liquid sealing agent, leave one to two threads open from the end, and avoid applying too much. Check that the sealing agent does not get on the device's threads.

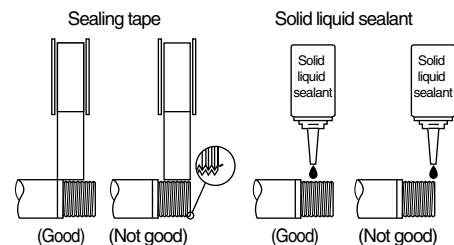

- Connect a joint even when using the stainless steel device with the OUT side opened. The port filter could come off.
- When using resin body, do not bend the tube near the push-in joint. If strain could be applied to the tube near the push-in joint, attach an insert ring onto the tube and insert into the push-in joint.
- When using resin body, accurately insert the tube and confirm that it does not dislocate even when pulled. Cut the tube at a right angle with a dedicated cutter before using.
- After piping, confirm that no gas is leaking.
- When using this product for oxygen gas, monitor the following points.
 - Piping work must be completed by personnel with expertise on handling oxygen gas.
 - Use oil-treated pipes.
 - Remove any dirt or burrs from piping before attaching to this product.
 - Attach a filter to the primary side of this product.



Flow controller

Safety Precautions

Always read before starting use

Small flow controller FCM series

During use & Maintenance

⚠ CAUTION

- Output accuracy is affected by the temperature characteristics and heat self-generated when energized. Provide a standby time (10 minutes or longer after turning power ON) when using.
- If a failure occurs during operation, turn power OFF immediately and stop use. Contact your dealer.
- This product does not flow control for two seconds after power is turned ON so it completes self-diagnosis. Provide a control circuit and program that ignore signals for two seconds after power is turned ON.
- Keep this product's flow within the rated flow range.
- Use this product within the operating differential pressure range.
- When the setting is changed, control devices could operate unintentionally. Stop devices before changing settings.
- Regularly inspect the product at least once a year and confirm that it is operating correctly.
- Do not disassemble or modify this product. Doing so could result in faults.
- This case is made of resin. Do not use solvent, alcohol, or detergent to remove any dirt, etc., as the resin could be impregnated. Wipe off any dirt with a rag soaked in a diluted neutral detergent solution and wrung out well.
- Monitor leading of the surge current
When controller power is shared with an inductive load that generates a surge, such as a solenoid valve or relay, if the circuit is cut off while the inductive load is functioning, the surge current could enter the output circuit and cause damage depending on where the surge absorption element is installed.

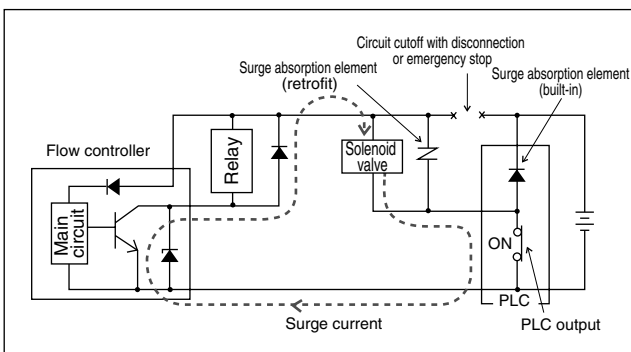

Take the following types of measures to prevent damage from surge current led in.

- ① Separate the power supply for output comprising the inductive load, such as the solenoid valve and relay, and input, such as the flow controller.
- ② If separate power supplies cannot be used, directly install a surge absorption element for all inductive loads. Note that the surge absorption element connected to the PLC, etc., protects only that device.
- ③ Connect a surge absorption element to the following on power wiring as shown below as a measure against disconnections in unspecified areas.

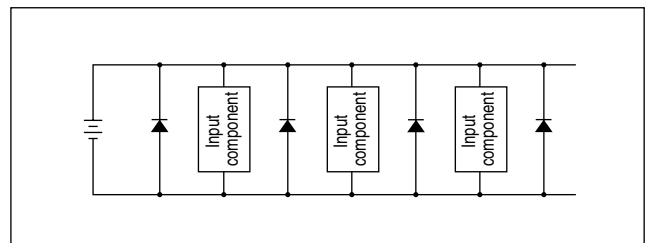

When devices are connected to a connector, the output circuit could be damaged by the above if the connector is disconnected while power is ON. Turn power OFF before connecting or disconnecting the connector.



Small size flow controller

FCM Series

- Flow rate: 0.5, 1, 2, 5, 10, 20, 50, 100 ℓ/min

Specifications

Descriptions		FCM-[*1] [*2]-[*3] [*4] [*5]										
Valve drive type		Proportional solenoid valve When not energized: Closed										
		Flow range	Al (air, nitrogen)	AR (argon)	O ₂ (oxygen)	LN (city gas)	C ₁ (methane)	C ₃ (propane)				
Full scale flow rate Note 1	*1	Standard model	9500	0 to 500 m ℓ/min	●	●	●	●	●			
			0001	0 to 1 ℓ/min	●	●	●	●	●			
			0002	0 to 2 ℓ/min	●	●	●	●	●			
			0005	0 to 5 ℓ/min	●	●	●	●	●			
			0010	0 to 10 ℓ/min	●	●	●	●	●			
			0020	0 to 20 ℓ/min	●	●	●	●	●			
			0050	0 to 50 ℓ/min	●	●	●	●	●			
			0100	0 to 100 ℓ/min (only resin type)	●	●	●	●	●			
			Low differential press. (only stainless steel)	*1	Standard model	L9500	0 to 500 m ℓ/min	●	●	●	●	●
						L0001	0 to 1 ℓ/min	●	●	●	●	●
L0002	0 to 2 ℓ/min	●				●	●	●	●			
L0005	0 to 5 ℓ/min	●				●	●	●	●			
L0010	0 to 10 ℓ/min	●				●	●	●	●			
Applicable fluids Note 2	*2	Al	Compressed air, nitrogen	●								
		AR	Argon		●							
		O ₂	Oxygen (oil-prohibit specifications)			●						
		LN	City gas (13A) Note 3				●					
		C ₁	Methane (CH ₄ 100%)					●				
		C ₃	Propane (C ₃ H ₈ 100%)						●			
Port size, Body material	*3	H6	ø6 push in, resin (excluding 50, 100 ℓ/min)	●								
		H8	ø8 push in, resin	●								
		8A	Rc1/4, stainless steel	●	●	●	●	●				
		UF	9/16-18UNF, stainless steel	●	●	●	●	●				
Control	Control range		3 to 100% F.S.									
	Responsiveness	*1	9500 to 0020, L9500 to L0020	Within 0.5 sec at setting ±5%F.S. (TYP)								
			0050 to 0100, L0050 to L0100	Within 1 sec at setting ±5%F.S. (TYP)								
	Accuracy		±3% F.S. or less									
	Repeatability		±1% F.S. or less									
	Temperature characteristics		±0.1% F.S./°C or less (25°C standard)									
Pressure characteristics		±1%F.S. or less per 98kPa (standard differential pressure reference)										
Pressure	Standard differential pressure		Note 4 Refer to separate table.									
	Operation differential pressure range		Note 5 Refer to separate table.									
	Withstanding pressure	*3	H6/H8 (resin body)	490 kPa								
8A/UF (SUS body)			980 kPa									
Ambient temperature and humidity			0 to 50 °C, 90% RH or less (with no dew condensation)									
Input/output	Input signal/ Pre-set input	*4	0	0 to 10 VDC (6.7kΩ)/4 points (2bit)								
			1	0 to 5 VDC (10kΩ)/4 points (2bit)								
			2	4 to 20 mA DC (250 Ω)/4 points (2bit)								
			P	Parallel 10bit/none								
	Output signal	*5	AN	Analog output: 1-5V (connected load impedance 500kΩ and over) Error output: NPN open collector output, 50mA or less, voltage drop 2.4V or less								
AP			Analog output: 1-5V (connected load impedance 500kΩ and over) Error output: PNP open collector output, 50mA or less, voltage drop 2.4V or less									
SN			Switch output: NPN open collector output, 50mA or less, voltage drop 2.4V or less Error output: NPN open collector output, 50mA or less, voltage drop 2.4V or less									
SP			Switch output: PNP open collector output, 50mA or less, voltage drop 2.4V or less Error output: PNP open collector output, 50mA or less, voltage drop 2.4V or less									
Flow rate display	Display method		3-digit 7-segment LED, display accuracy: control accuracy ± 1 digit									
	Display range and resolution		Refer to separate table.									
Integrating function			Refer to separate table.									
Power supply	Power supply voltage		24VDC±10% (stabilized power with ripple rate 2% or less)									
	Current consumption		250 mA or less									
Installation attitude			Free									
Wetted area material	*3	H6/H8 (resin body)	Polyamide resin, fluoro rubber, stainless steel, alumina, silicon, solder									
		8A/UF (SUS body)	Stainless steel, fluoro rubber, alumina, silicon, solder									
Weight	*3	H6/H8 (resin body)	Approx. 200g									
		8A/UF (SUS body)	Approx. 480g									
Protective structure			IEC standards IP40									
Protective circuit			Note 6 Power reverse connection protection, switch output reverse connection protection, switch output load short-circuit protection									
EMC Directive			EN55011, EN61000-6-2, EN61000-4-2/3/4/6/8									

Pressure

Standard differential pressure and operation differential pressure Note 4, 5

(Standard model)

		Flow rate range *1								
		9500	0001	0002	0005	0010	0020	0050	0100	
Applicable fluids *2	AI	Standard differential pressure (kPa)	50	100	100	100	100	150	200	300
		Operation differential pressure (kPa)	20 to 150	50 to 200	50 to 250	50 to 250	50 to 250	100 to 300	150 to 300	250 to 350
	AR	Standard differential pressure (kPa)	50	100	100	100	100	150	200	
		Operation differential pressure (kPa)	20 to 150	50 to 200	50 to 250	50 to 250	50 to 250	100 to 300	150 to 300	
	O2	Standard differential pressure (kPa)	50	100	100	100	100			
		Operation differential pressure (kPa)	20 to 150	50 to 200	50 to 250	50 to 250	50 to 250			
LN/C1	Standard differential pressure (kPa)	50	50	50	50	50				
	Operation differential pressure (kPa)	20 to 150	20 to 150	20 to 150	20 to 150	30 to 150				
C3	Standard differential pressure (kPa)	50	50	50	50	50				
	Operation differential pressure (kPa)	20 to 150	20 to 150	20 to 150	20 to 150	30 to 150				

(Low differential pressure model)

		Flow rate range *1					
		L9500	L0001	L0002	L0005	L0010	
Applicable fluids *2	AI/O2	Standard differential pressure (kPa)	20	20	20	20	20
	LN/C1						
	C3	Operation differential pressure (kPa)	5 to 50	5 to 50	5 to 50	5 to 50	10 to 50

Display and integrating function

		Flow rate range *1							
		9500 L9500	0001 L0001	0002 L0002	0005 L0005	0010 L0010	0020	0050	0100
Flow rate display	Display range	0 to 500 m l/min	0.00 to 1.00 l/min	0.00 to 2.00 l/min	0.00 to 5.00 l/min	0.0 to 10.0 l/min	0.0 to 20.0 l/min	0.0 to 50.0 l/min	0 to 100 l/min
	Display resolution	1 m l/min	0.01 l/min	0.01 l/min	0.01 l/min	0.1 l/min	0.1 l/min	0.1 l/min	1 l/min
Integrating function	Display range	999999 m l	9999.99 l	9999.99 l	9999.99 l	99999.9 l	99999.9 l	99999.9 l	999999 l
	Display resolution	1 m l	0.01 l	0.01 l	0.01 l	0.1 l	0.1 l	0.1 l	1 l
	Pulse output rate	5 m l	0.01 l	0.02 l	0.05 l	0.1 l	0.2 l	0.5 l	1 l

Note 1: Converted to volumetric flow at 20°C 1 barometric pressure (101 kPa).

Note 2: When using compressed air, use clean air complying with JIS B 8392-1:2003 Class 1.1.1 to 1.6.2. Compressed air from the compressor contains drainage (water, oxidized oil, foreign matter, etc.). Install a filter (filtration: 5 µm), air dryer (minimum pressure dew point 10°C or less) and oil mist filter (maximum oil concentration 0.1 mg/m³) on the primary side of this product to maintain product function.

<Recommended circuit >

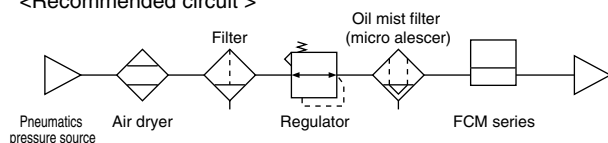

<Recommended component >

Air filter: F series

Oil mist filter: M series

When using for purposes other than compressed air, use dry gas that does not contain corrosive elements such as chlorine, sulfur or acids, and clean gas that does not contain dust or oil mist.

Note 3: City gas 13 A is for methane (CH₄) 88% gas generated from LNG.

Note 4: The standard differential pressure is the differential pressure when this product is calibrated.

Note 5: The operating differential pressure is the differential pressure required for this product to operate normally. Contact CKD when using this product at a level exceeding the operating differential pressure.

Note 6: This product's protective circuit is effective only for specific incorrect connections and load short-circuits. It does not necessarily provide protection for all incorrect connections.

How to order

FCM - 9500 AI - H6 0 AN R 1 B T

Model No.

① Traceability

⑧ Bracket

⑨ Flow rate range

⑩ Applicable fluids

⑪ Port/body material

⑫ Input specifications

⑬ Output specifications

⑭ Display direction

⑮ Cable

Symbol	Descriptions					
⑨ Flow rate range						
Applicable fluids						
	AI	AR	O2	LN	C1	C3
9500	●	●	●	●	●	●
0001	●	●	●	●	●	●
0002	●	●	●	●	●	●
0005	●	●	●	●	●	●
0010	●	●	●	●	●	●
0020	●	●				
0050	●	●				
0100	●					
	Standard model					
	0 to 0.5 ℓ /min					
	0 to 1 ℓ /min					
	0 to 2 ℓ /min					
	0 to 5 ℓ /min					
	0 to 10 ℓ /min					
	0 to 20 ℓ /min					
	0 to 50 ℓ /min					
	0 to 100 ℓ /min (only resin body)					
	Low differential press. (Only stainless steel)					
L9500	●		●	●	●	●
L0001	●		●	●	●	●
L0002	●		●	●	●	●
L0005	●		●	●	●	●
L0010	●		●	●	●	●
⑩ Applicable fluids						
AI	Compressed air, nitrogen gas					
AR	Argon					
O2	Oxygen (oil-prohibit specifications)					
LN	City gas (13A)					
C1	Methane (CH ₄)					
C3	Propane (C ₃ H ₈)					
⑪ Port/body material						
Applicable fluids						
	AI	AR	O2	LN	C1	C3
H6	●					
H8	●					
8A	●	●	●	●	●	●
UF Note 1	●	●	●	●	●	●
⑫ Input specifications						
0	Analog 0 to 10 VDC					
1	Analog 0 to 5 VDC					
2	Analog 4 to 20 mADC					
P	Parallel 10bit					
⑬ Output specifications						
AN	1 to 5 V analog error (NPN)					
AP	1 to 5 V analog error (PNP)					
SN	Switch (NPN), error (NPN)					
SP	Switch (PNP), error (PNP)					
⑭ Display direction						
Blank	Positive direction					
R	Reverse direction					
⑮ Cable						
Blank	None					
1	1 m					
3	3 m					
⑯ Bracket						
Blank	None					
B	With bracket					
⑰ Traceability						
Blank	None					
T	Traceability certificate, system diagram, inspection results included					
K	Inspection results included					

<Example of model No.>

FCM-0001AI-H81ANR1BK

Model: Small size flow controller FCM series

- ⑨ Flow rate range : 0 to 1 ℓ /min
- ⑩ Applicable fluids : Compressed air, nitrogen
- ⑪ Port/body material : Push in (ø8), resin body
- ⑫ Input specifications: Analog 0 to 5 VDC
- ⑬ Output specifications: 1 to 5 V analog, error (NPN)
- ⑭ Display direction : Reverse direction
- ⑮ Cable : 1 m
- ⑯ Bracket : With bracket
- ⑰ Traceability : Inspection results included

⚠ Note on model No. selection

Note 1: Refer to the dimensions on page 4 for the 9/16-18UNF screw shape.

Discrete option model

FCM - AC1

Symbol	Descriptions
AC1	9-conductor analog cable 1m
AC3	9-conductor analog cable 3m
PC1	15-conductor parallel cable 1m
PC3	15-conductor parallel cable 3m
LB1	Bracket

Dimensions

Body material: Resin, port size: $\phi 6$, $\phi 8$

● FCM-*H8/H6*

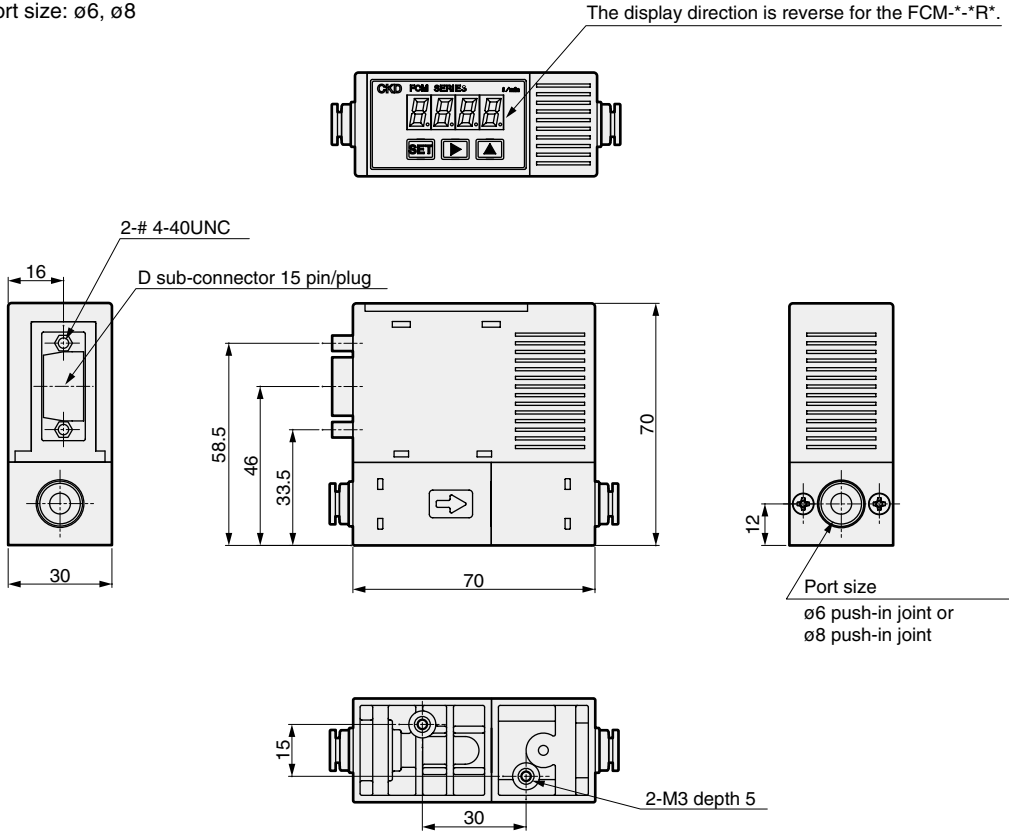

Body material: Stainless steel, port size: Rc1/4, 9/16-18UNF

● FCM-*8A/UF

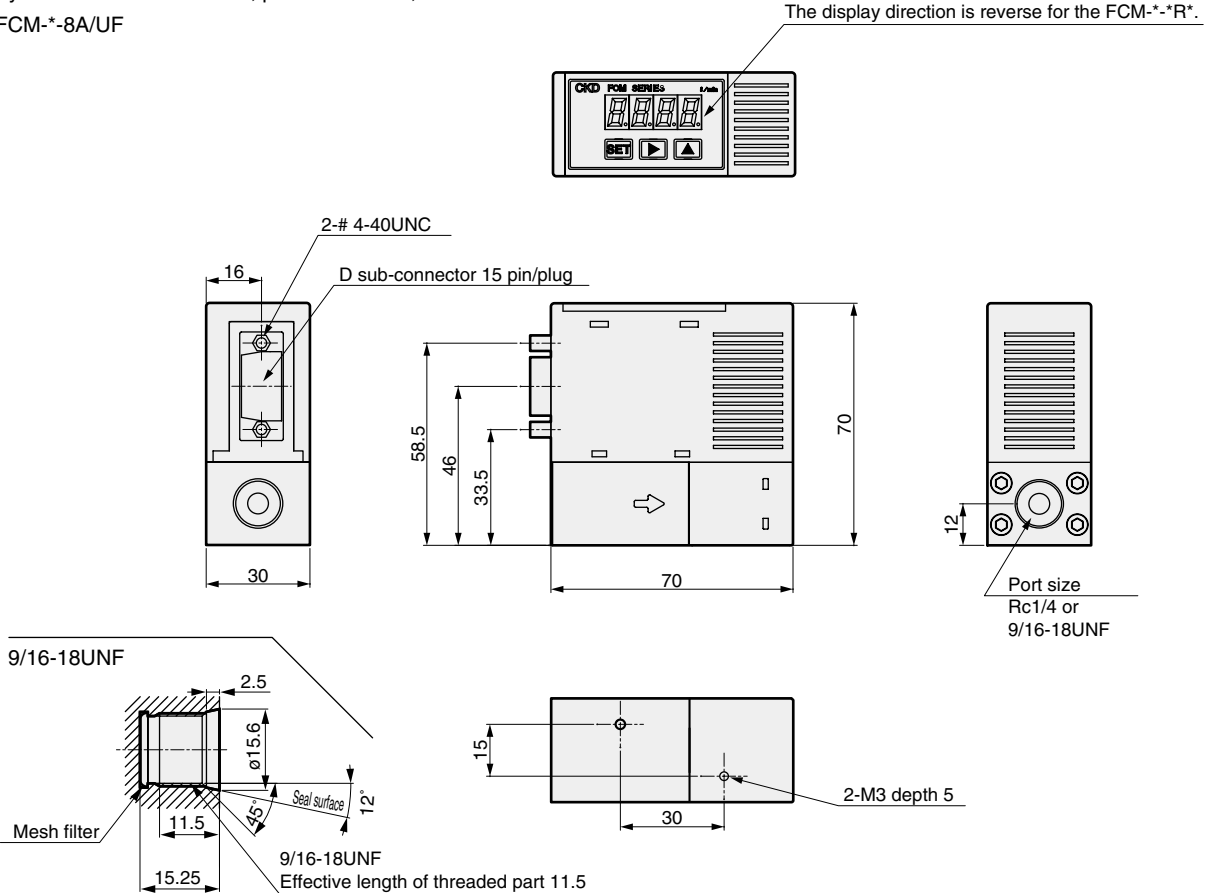

Dedicated bracket (Floor installation type)

Discrete model: FCM-LB1

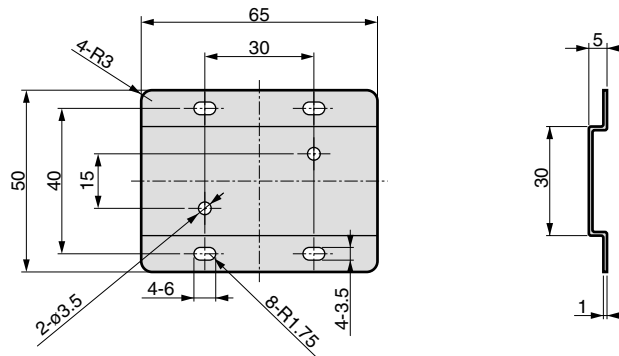

Cable option dimension drawing

- 9-conductor cable for analog input type
Discrete option model: FCM-AC1, AC3

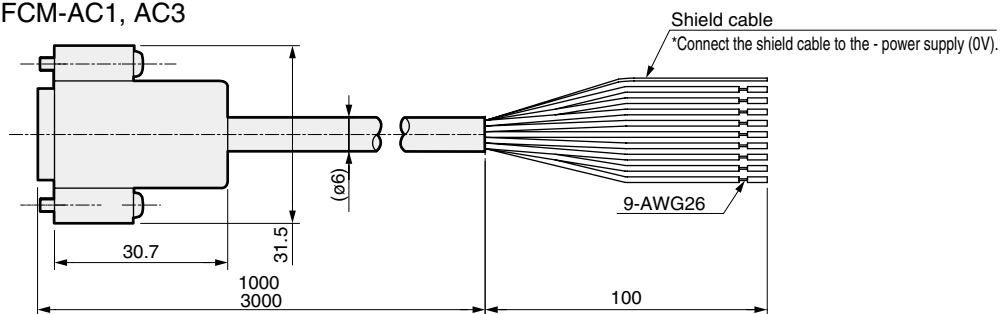

D sub socket pin No.	1	2	3	4	5	6	7	8	9	10	11	12	13	14	15
Insulator color	Brown	Orange	Yellow	-	Red	-	-	-	-	Gray	White	-	Green	Blue	Black
Name	Pre-set input function		Integration reset signal	Not used	Power supply+	Not used	Not used	Not used	Not used	Common	Input signal zero/span adjustment function	Not used	Analog input	Switch output	Error output
Type of input	Bit 1	Bit 2			+24 VDC						0 to 10 VDC	0 to 5 VDC	1 to 5 VDC	NPN or PNP output	NPN or PNP output
											4 to 20 mADC				Power supply- (0V)

Note: The No. 1 pin common is common for the preset input and integration reset signal (No 1 to 3 pins).

- 15-conductor cable for parallel input type
Discrete option model: FCM-PC1, PC3

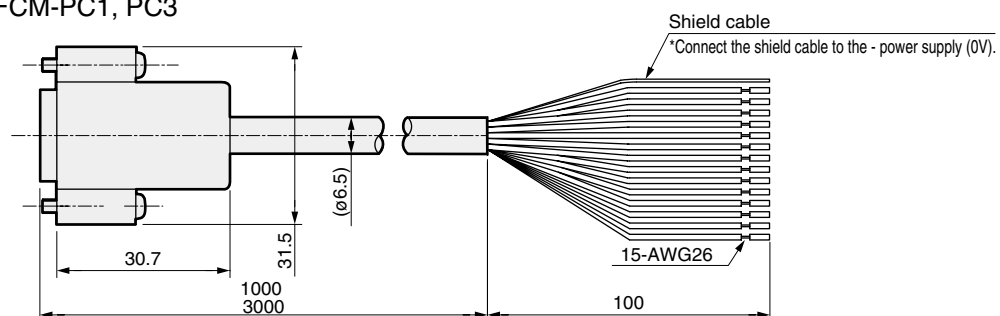

D sub Socket Pin No.	1	2	3	4	5	6	7	8	9	10	11	12	13	14	15	
Insulator color	Brown	Orange	Yellow	Purple	Red	Light blue	Pink	White (with black line)	Red (with black line)	Gray	White	Green (with black line)	Green	Blue	Black	
Name	Parallel input signal				Power supply+	Parallel input signal				Common	Parallel input signal		Analog input function	Switch output function	Error automatic shutdown applicable error (Note)	Power supply- (0V)
Type of input	Bit 1	Bit 2	Bit 3	Bit 4	+24 VDC	Bit 5	Bit 6	Bit 7	Bit 8		Bit 9	Bit 10	1 to 5 VDC	NPN or PNP output	NPN or PNP output	

Note: The No. 10 pin common is common for the parallel input signals (No. 1 to 4, 6 to 9, 11, 12 pins).

Wiring method

Example of internal circuit and load connection, analog input type

FCM-*0/1/2 AN*
(Analog input, analog output + error output type NPN output)

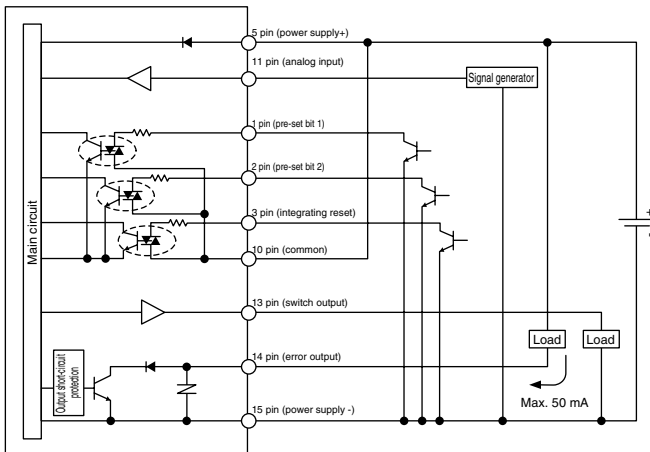

FCM-*0/1/2 AP*
(Analog input, analog output + error output type PNP output)

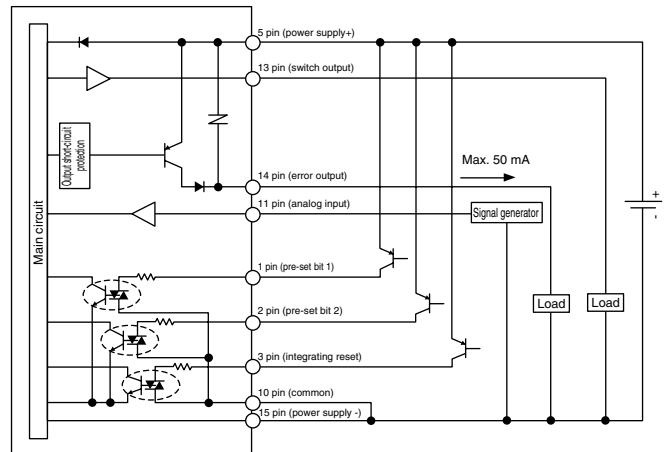

FCM-*0/1/2 SN*
(Analog input, switch output + error output type NPN output)

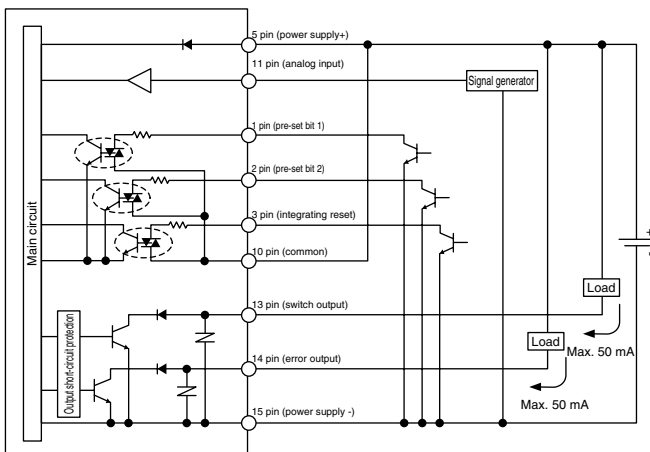

FCM-*0/1/2 SP*
(Analog input, switch output + error output type PNP output)

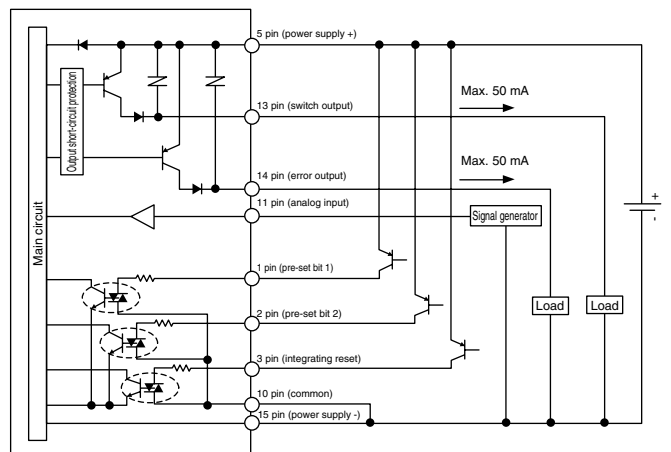

■ Connector pin layout (body side)
[Analog input type]

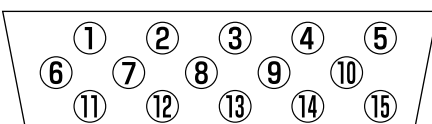

The analog input type does not have the 4, 6, 7, 8, 9 or 12 pins.

Example of internal circuit and load connection, parallel input type

FCM-*-*PAN*
(Parallel input, analog output + error output type NPN output)

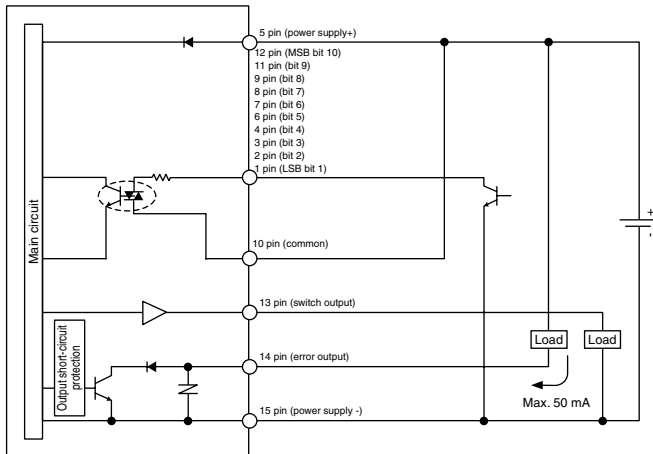

FCM-*-*PAP*
(Parallel input, analog output + error output type PNP output)

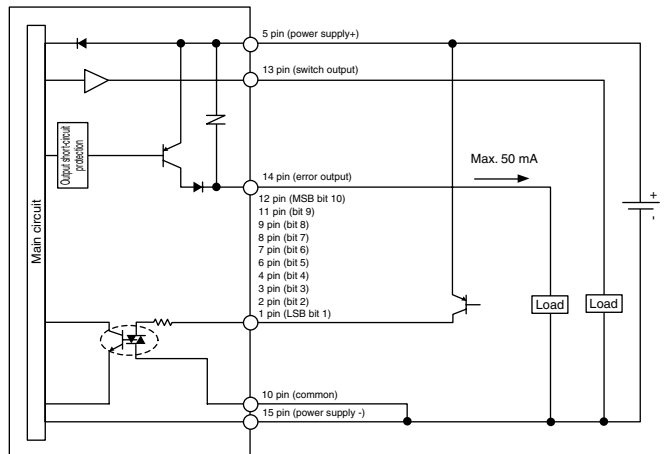

FCM-*-*PSN*
(Parallel input, switch output + error output type NPN output)

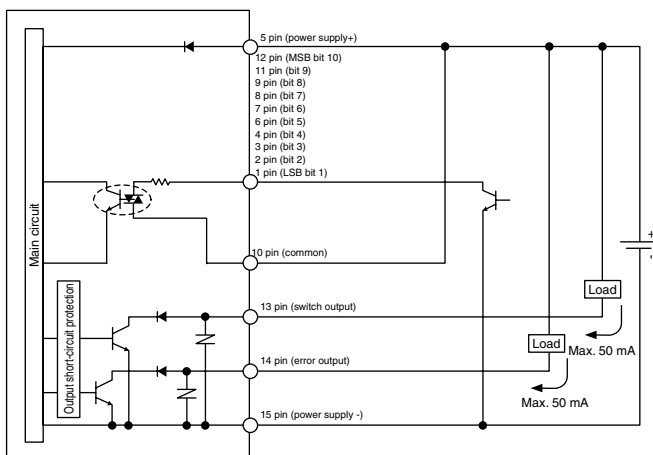

FCM-*-*PSP*
(Parallel input, switch output + error output type PNP output)

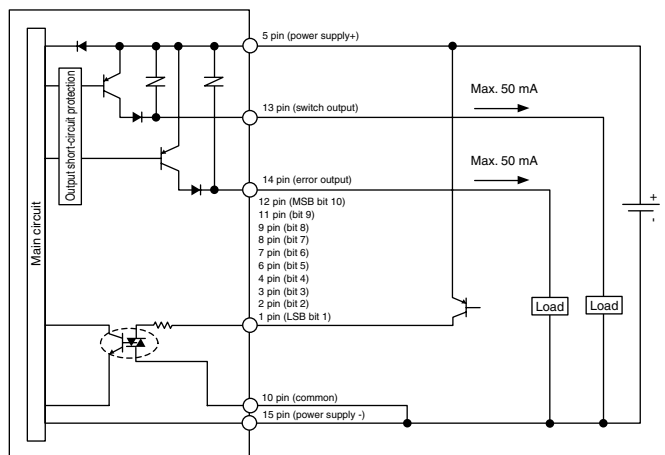

■ Connector pin layout (body side)
[Parallel input type]

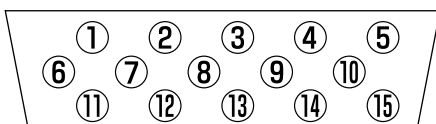

Small Flow Controller FCM Series Functions

Explanation of functions

Function	Details	Compatible models				Operation
		Analog input		Parallel input		
		Analog output function	Switch output function	Analog output function	Switch output function	
Direct memory function	The target is input with keys. Even if input signals from an external source are not used, control flow rate is freely adjusted with controller operation keys.	○	○	○	○	P10, 11 P21
Preset input function	When four random flow rate points are set, the flow rate is controlled by inputting a 2-bit signal from an external source (signals from PLC, etc.).	○	○			P12 P21
Analog input function	The flow rate is controlled with analog input signals.	○	○			P14 P21
Parallel input function	The flow rate is controlled with a parallel 10-bit (signal from PLC, etc.) Expensive input/output devices, such as a D/A converter, are not required.			○	○	P15 P21
Integrating function	The flow rate is integrated. The following functions are used in addition to the integrated flow display. <ul style="list-style-type: none"> The solenoid valve is closed and stopped at the set integrated flow. Integrated pulse function (only switch output) Switch ON at set integrated flow (only switch output) Resetting the integrated value <ul style="list-style-type: none"> Analog input: External input, button operations Parallel input: Only button operations 	No integrated pulse switch	○	No integrated pulse switch	○	P16 P17 P20 P22 P23
Switch output function	The following switch functions are selected. <ul style="list-style-type: none"> (1) Tolerance mode: The switch turns ON when the level is within the tolerance (randomly set) of control target. (2) Range designation mode: The switch turns ON when the level is not within the designated flow rate range. (3) Integrated pulse: The integrated pulse is output during integration. (4) ON when higher than set integration: The switch turns ON at the set integrated flow. <p>See page 2 for details on the pulse output rate.</p>		○		○	P17 P18 P19 P22
Input signal zero/span adjustment function	The input signal's zero point and span point is changed. 	○	○			P22
Zero point adjustment	The flow rate output's zero point is adjusted.	○	○	○	○	P23
Automatic power off	The flow rate display turns OFF if there are no operations for one minute. (Control does not stop when the auto power OFF function activates.) Power is saved since the display is turned OFF when not needed.	○	○	○	○	P22
Error display function	The error state is displayed. The following functions are used for the error display. <ul style="list-style-type: none"> Error output is turned ON if an error occurs Control stops automatically an error occurs 	○	○	○	○	P9 P23
Error automatic shutoff	If an error occurs, control is stopped, the valve is fully opened, and error output is turned ON.	○	○	○	○	P23
Key lock	Setting changes are disabled to prevent incorrect operations.	○	○	○	○	P20
Setting reset	Settings are returned to defaults.	○	○	○	○	P20

Names and functions of display and operation section

Output display (red)

- "F" is displayed while confirming function settings.
- "*" is displayed when switch output is ON.
(Only switch output)
* The display blinks when overcurrent is detected.
* The display does not blink with integrated pulse output.
- "E" is displayed when error output is ON.
* The display blinks when overcurrent is detected.

* If an upper/lower limit applies when setting the function, or when displaying both the high-order digit and low-order digit of the integrated flow display, H or L is displayed.

3-digit number LED display (green)

- The instantaneous flow rate display and function setting details are displayed in the RUN mode (instantaneous flow rate display).
- * The setting mode No. and setting details are displayed when displaying details of function settings.
- Values, etc., are displayed when setting each data.
- The error code No. is displayed when the error is displayed.

<Instantaneous flow rate display>

<Setting details display>

Setting details
Setting mode No.

<Error output>

Code No.

<Invalid display>

Setting details
Setting mode No.

UP key (MODE key)

- Press to count up the value, etc.
- Press to change the setting mode.
- Press to change the setting item.

SET key

- Press to set the setting mode.
- Press to set the setting item.
- Press to change to the integrated display.

Shift key (OFF key)

- Press to select the digit for a number, etc.
- When forced OFF (control stop) is executed, this key is pressed to restore operation from the forced OFF state.

SET + Shift key (ENT key)

- Press to set the value.
- Press to unlock the key lock.
- Press to execute integration reset.

SET + UP key (DOWN key)

- Press to count down the value, etc.
- Press to lock keys.

Shift + UP key

- Press to initialize values.

Error code table

Error display	Cause	Measures	Errors subject to error automatic shutoff (Note)
	The supplied power voltage is not within the rating.	● Check controller power specifications, set power voltage within the rating range, and turn power ON again.	○
	The input signal exceeds the rating range.	● Check the controller input signal type, set the input signal within the rating range, and turn power ON again.	○
	An error occurred during EEPROM reading or writing.	● Contact your nearest CKD Sales Office or dealer.	
	An error occurred during memory reading or writing.	● Contact your nearest CKD Sales Office or dealer.	
	The flow rate did not reach the setting for five and over consecutive seconds.	<ul style="list-style-type: none"> ● Check the primary pressure, supply pressure within the rated operating differential pressure range, and turn power ON again. ● Check that there are no leaks from piping, joints, or other devices, correct connect pipes, and turn power ON again. ● Contact your nearest CKD Sales Office or dealer. 	○
	An output error is occurring in the sensor.	<ul style="list-style-type: none"> ● Stop the supply of fluids to the controller, set the flow rate to zero, and turn the controller power ON again. If this error occurs again, contact your nearest CKD Sales Office or dealer. 	○
	Switch output overcurrent protection circuit is activated.	● Check whether load current exceeds the rating, correctly connect the controller, and turn power ON again.	

Errors are basically automatically reset. However, if the error is not reset, turn power OFF, check the cause and correct the error. Then, turn power ON again.
 Note: The default is error automatic shutoff set to OFF (valve fully closed if an error occurs). See page 23 for details.

Controlling the flow rate

(1) Controlling the flow rate with direct memory

The target is input with keys. Even if input signals from an external source are not used, control flow rate is freely adjusted with controller operation keys. Direct memory has two operation modes.

- Direct memory (1): Settings are applied when the value is changed. (Even if the value is not set, the flow rate is adjusted by changing the value. This is handy for finely adjusting the flow rate. Set the setting once the flow rate is determined.)
- Direct memory (2): Changes are applied when the value is set. (The flow rate does not change unless the value is set.)

<Direct memory (1) operation>

(1) Turn power ON. The instantaneous flow rate is displayed.

(2) When the  key is pressed, the <F1: Input signal confirmation> screen is displayed. The current input signal setting state is displayed.

The current input signal type and input are alternately displayed.



(The instantaneous flow rate display is displayed if 3 seconds pass without a button being pressed.)

(3) "F1.dr" blinks when the  key is held down for 2 seconds.

(4) Hold down the  key for 2 seconds and open the <Direct Memory 1 Setting screen>.

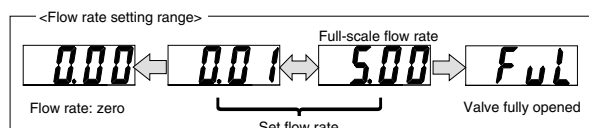
(5) The flow rate changes when the value is change. The flow rate is adjusted by changing the value even if the value is not set.



(6) Hold down the  and  keys together for 2 seconds, and set the value. The <F1: input signal confirmation> screen is displayed.

(7) The instantaneous flow rate display is redisplayed after 3 seconds.

Forced OFF (flow rate zero)

The controller is forcibly stopped (flow rate zero) by holding down the  key for 2 seconds in the flow control state (instantaneous flow rate display).

The flow control state is entered again by holding down the  key for 2 seconds in the flow control stopped state (forced OFF).

<Instantaneous flow rate display >

0.00

The instantaneous flow rate display is redisplayed after 3 s.

<F1: Input signal confirmation>

F1.dr

<Input display>

0.00

 Hold down for 2 s.

F1.dr

 Hold down for 2 s.

0.00

5.00

  Hold down for 2 s.

<F1: Input signal confirmation>

F1.dr

<Input display>

5.00

<Instantaneous flow rate display >

5.00

<Instantaneous flow rate display>

Flow control state

5.00

 Hold down for 2 s.

<Forced OFF display>

Flow control stopped state

OFF

The solenoid valve forced OFF state is displayed. Control is forcibly stopped even the input signal is input.

Controlling the flow rate

<Direct memory (2) operation>

(1) Turn power ON. The instantaneous flow rate is displayed.

<Instantaneous flow rate display >

0.00

The instantaneous flow rate display is redisplayed after 3 s.

- (2) When the  key is pressed, the <F1: Input signal confirmation> screen is displayed. The current input signal setting state is displayed. The current input signal type and input are alternately displayed. (The instantaneous flow rate display is displayed if 3 seconds pass without a button being pressed.)

<F1: Input signal confirmation>

F1.dr

<Input display>

0.00

Alternate display

Hold down for 2 s.

<Input signal type >

Direct memory input	: dr
Analog input 0 to 10V	: A0
Analog input 0 to 5V	: A1
Analog input 4 to 20 mA	: A2
Parallel input	: PA
Pre-set input	: P1

- (3) "F1.dr" blinks when the  key is held down for 2 seconds.





F1.dr

Hold down for 2 s.

- (4) Hold down the  and  keys for 2 seconds, and open the <direct memory (2) setting screen>.

20.00



<Target setting>

	key : Moves the digit
	key : Counts up the value
 	key : Count down the value

- (5) Change the value. (The flow rate does not change unless the value is set.)

25.00

Hold down for 2 s.

- (6) Hold down the  and  keys together for 2 seconds, and set the value. The <F1: input signal confirmation> screen is displayed.

<F1: Input signal confirmation>

F1.dr

<Input display>

5.00

Alternate display

- (7) The instantaneous flow rate display is redisplayed after 3 seconds.

<Instantaneous flow rate display >

5.00

Forced OFF (flow rate zero)

The controller is forcibly stopped (flow rate zero) by holding down the  key for 2 seconds in the flow control state (instantaneous flow rate display).

The flow control state is entered again by holding down the  key for 2 seconds in the flow control stopped state (forced OFF).

<Instantaneous flow rate display >

Flow control state

5.00

<Forced OFF display>

Flow control stopped state

off

Hold down for 2 s.

The solenoid valve forced OFF state is displayed. Control is forcibly stopped even the input signal is input.

Note:

- Control does not stop while setting direct memory. Take safety into consideration, and stop control (forced stop) if necessary.
- The flow control/forced OFF state (setting) is held even if power is turned OFF.

Controlling the flow rate

(2) Controlling the flow rate with preset input (only analog input)

When four random flow rate points are set, the flow rate is controlled by inputting a 2-bit signal from an external source.

Example: To control 0, 1, 2, and 5 ℓ /min with preset input, select Preset Input for the input setting mode, and set each of the following:

P1: 0 ℓ /min P2: 1 ℓ /min

P3: 2 ℓ /min P4: 5 ℓ /min

When signals are input from a PLC, etc., as indicated in the table at right, the flow rate is controlled to each preset flow rate.

D-sub socket pin No.	2	1	Pre-set memory No.
Cable option insulator color	Orange	Brown	
Type of input	Bit 2	Bit 1	
Input signal	OFF	OFF	P1
	OFF	ON	P2
	ON	OFF	P3
	ON	ON	P4

<Controlling with the preset input signal>

- Turn power ON. The instantaneous flow rate is displayed.
- When the key is pressed, the <F1: Input signal confirmation> screen is displayed. The current input signal setting state is displayed. The current input signal type and input are alternately displayed. (The instantaneous flow rate display is displayed if 3 seconds pass without a button being pressed.)
- "F1.dr" blinks when the key is held down for 2 seconds.
- When the key is pressed twice, "F1.P1" will blink.
- Hold down the key for 2 seconds, and open the P1 setting confirmation screen.
- Hold down the key for 2 seconds, and open the target input screen. Input the target.
- When the and key are held down for 2 seconds, the target is set in memory, and the P2 setting confirmation screen is displayed. Set all of the targets up to P4 with this.
- The instantaneous flow rate display is redisplayed after 3 seconds. The flow is controlled with preset input.

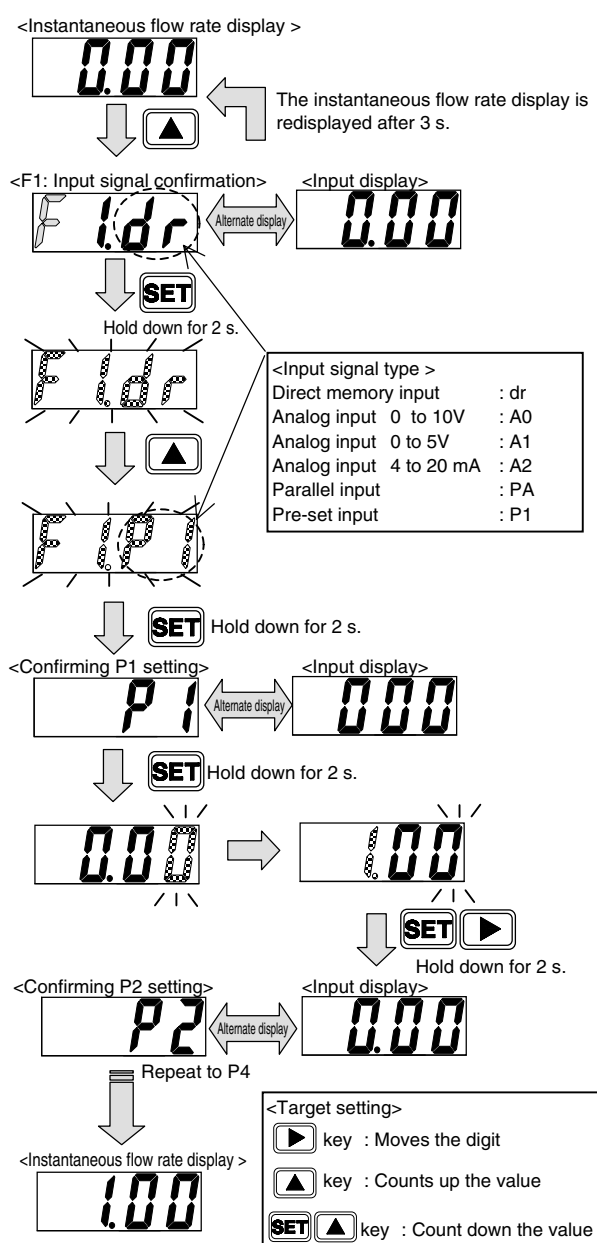

Controlling the flow rate

(3) Changing settings with shortcut keys (only when using direct memory and preset input)



When controlling the flow using direct memory or preset input, the setting change screen is opened with a single key operation.

Note: The input signal setting change screen opens the instant that the shortcut key is pressed.
 (Example: The P2 setting change screen opens when controlling the flow with the preset input P2.)
 This cannot be used when controlling the flow with analog input or parallel input.

<Changing the setting with a shortcut>









(1) Turn power ON. The instantaneous flow rate is displayed.
 (This is used only when controlling with direct memory or preset input.)



<Instantaneous flow rate display >
 Control when flowing with preset memory P2





(2) When the  key is held down for 3 seconds, and the  key is pressed, the input signal setting change screen is displayed.

↓  Hold down for 3 s.
 <F1: input signal confirmation> and <input display> are alternately displayed during this time.

(3) The flow rate changes when the value is change. The flow rate is adjusted by changing the value even if the value is not set.

↓     Hold down for 2 s.
 <Target setting>
 key : Moves the digit
 key : Counts up the value
  key : Count down the value

(4) Hold down the  and  keys together for 2 seconds, and set the value. The <F1: input signal confirmation> screen is displayed.

↓   Hold down for 2 s.
 <F1: Input signal confirmation> <Input display>
 ↔ Alternate display ↔ 

(5) The instantaneous flow rate display is redisplayed after 3 seconds.

↓ <Instantaneous flow rate display >

Note: Do not change the preset external input while changing the setting with the shortcut key.
 The setting could be set into an incorrect preset No.
 Data is not saved in memory if power is turned OFF before setting the value. Set the value before turning power OFF.

Controlling the flow rate

(4) Controlling the flow rate with analog input (Only analog input)

The flow rate is controlled with analog input signals.

<Controlling with analog input signals>

(1) Turn power ON. The instantaneous flow rate is displayed.

(2) When the  key is pressed, the <F1: Input signal confirmation> screen is displayed. The current input signal setting state is displayed. The current input signal type and input are alternately displayed. (The instantaneous flow rate display is displayed if 3 seconds pass without a button being pressed.)

(3) "F1.dr" blinks when the  key is held down for 2 seconds.

(4) When the  key is pressed once, "F1.A 0" will blink. (The number shown in differs based on the model.)

(5) Hold down the  key for 2 seconds and set the value. The <F1: input signal confirmation> screen is displayed.

(6) The instantaneous flow rate display is redisplayed after 3 seconds. The flow rate is controlled with analog input.

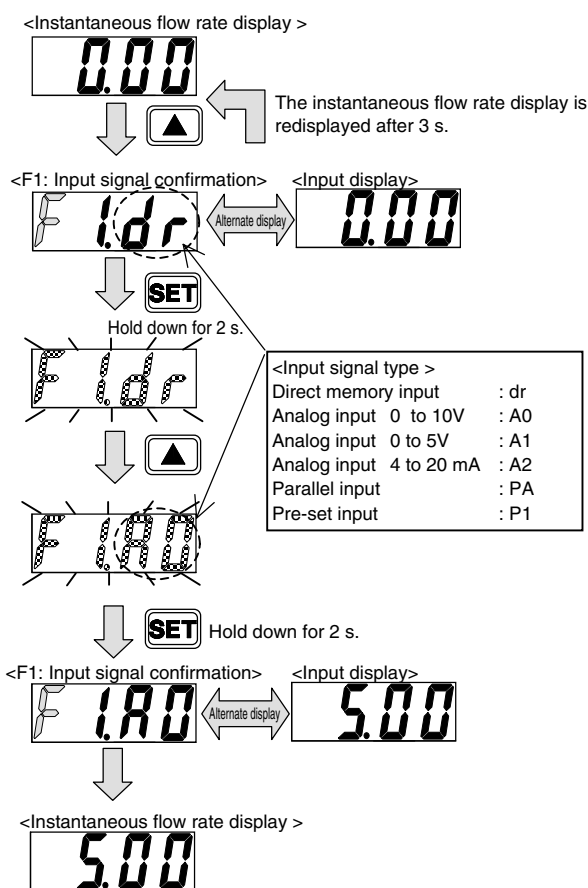

Note: Fully open (FUL) cannot be set with analog input.

Controlling the flow rate

(5) Controlling the flow rate with parallel input (Only parallel input)

The flow rate is controlled with a parallel 10-bit (signal from PLC, etc.) Expensive input/output devices, such as a D/A converter, are not required. The parallel input signal is a 10-point signal so when converted to a decimal, it becomes 0-1023. A 0.1% resolution is attained.

$$\text{Input signal} = \text{Set flow/full-scale flow} \times 1023$$

Example: To set 300 m³ /min with a full-scale flow 500 m³ /min

$$300 \text{ (m}^3 \text{ /min)} / 500 \text{ (m}^3 \text{ /min)} \times 1023 = 613.8 \rightarrow 614$$

When 614 (decimal) is converted to binary, it becomes 1001100110. 1 sets the input signal ON, and 0 sets the input signal OFF. (Refer to following table.)

D-sub socket pin No.	12	11	9	8	7	6	4	3	2	1
Cable option insulator color	Green (Black line)	White	Red (Black line)	White (Black line)	Pink	Light blue	Purple	Yellow	Orange	Brown
Type of input	Bit 10 MSB	Bit 9	Bit 8	Bit 7	Bit 6	Bit 5	Bit 4	Bit 3	Bit 2	Bit 1 LSB
Decimal [For 614 (decimal)]	1	0	0	1	1	0	0	1	1	0
Input signal	ON	OFF	OFF	ON	ON	OFF	OFF	ON	ON	OFF

<Controlling with parallel input signals>

(1) Turn power ON. The instantaneous flow rate is displayed.

(2) When the  key is pressed, the <F1: Input signal confirmation> screen is displayed. The current input signal setting state is displayed. The current input signal type and input are alternately displayed. (The instantaneous flow rate display is displayed if 3 s pass without a button being pressed.)

(3) "F1.dr" blinks when the  key is held down for 2 s.

(4) When the  key is pressed once, "F1.PA" will blink.

(5) Hold down the  key for 2 s and set the value. The <F1: input signal confirmation> screen is displayed.

(6) The instantaneous flow rate display is redisplayed after 3 seconds. The flow rate is controlled with parallel input.

Note: Fully open (FUL) cannot be set with parallel input.

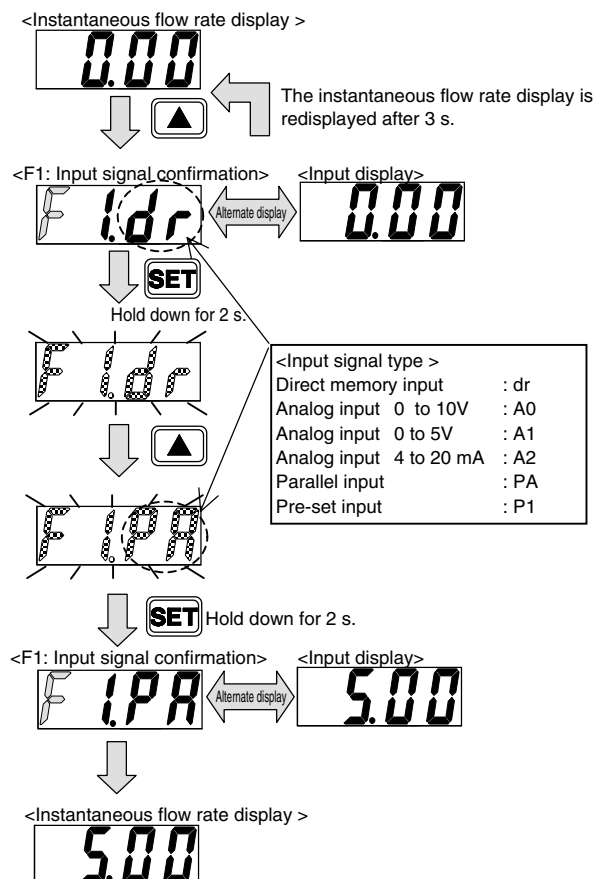

<Reference>

If a high resolution is not required, the number of input points is reduced.

Example: If 2% resolution is acceptable, operate with a 6-point input (0-63 when converted to decimal).

Bits 5 to 1 in the above table are shorted in a bundle. When turned ON and OFF as one bit (LSB), control is executed with 6 points.

Integrating the flow rate

(1) Displaying the integrated flow

The flow rate is integrated and displayed. The display range is shown below.

Model No. FCM-		9500 L9500	0001 L0001	0002 L0002	0005 L0005	0010 L0010	0020	0050	0100
Flow rate display	Display range	0 to 500 m l /min	0.00 to 1.00 l /min	0.00 to 2.00 l /min	0.00 to 5.00 l /min	0.0 to 10.0 l /min	0.0 to 20.0 l /min	0.0 to 50.0 l /min	0 to 100 l /min
Integrating function	Display range	999999 m l	9999.99 l	9999.99 l	9999.99 l	99999.9 l	99999.9 l	99999.9 l	999999 l
	Display resolution	1 m l	0.01 l	0.01 l	0.01 l	0.1 l	0.1 l	0.1 l	1 l
	Pulse output rate	5 m l	0.01 l	0.02 l	0.05 l	0.1 l	0.2 l	0.5 l	1 l

<Integrated display>

- Instantaneous flow rate display**
The integration starts when power is turned ON.
(The integrated value is reset when power is turned OFF.)
- The integrated display screen opens when the **SET** key is held down for 2 seconds. Press the **SET** key for 2 seconds to return to the instantaneous flow rate display. The display digit changes when the **▶** key is pressed.
- Integration is reset when the **SET** and **▶** keys are held down for 2 seconds. With analog, integration is reset with the external input (No. 3 pin). Integration is also reset when power is turned OFF.

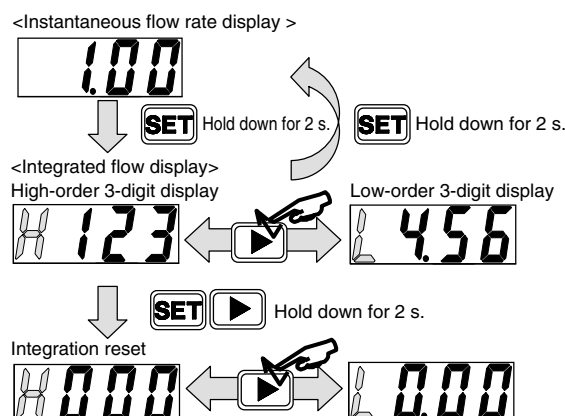

(2) Closing and stopping the solenoid valve with set integrated flow

The solenoid valve is closed and stopped when the set integrated flow is attained. This is suitable for processes in which a set amount is supplied, etc.

<Operation>

- Instantaneous flow rate display**
- Press the **▲** key five times and open the <F5: integration automatic shutoff setting screen>. If integration automatic shutoff is valid, "F5.on" and the current setting are alternately displayed. (The instantaneous flow rate display is displayed if 3 seconds pass without a button being pressed.)
- When the **SET** key is held down for 2 seconds, "F5.--" blinks. When not using integration automatic shutoff, hold down the **SET** key for 2 seconds. The <F5 screen> is redisplayed, and after 3 seconds, the instantaneous flow rate screen is displayed.
- To use integration automatic shutoff, press the **▲** key so that "F5.on" blinks. Then, hold down the **SET** key for 2 s.
After setting the high-order digit, hold down the **SET** key and **▶** key for 2 seconds.
After setting the low-order digit, hold down the **SET** key and **▶** key for 2 seconds.
The <F5 screen> is displayed, and after 3 seconds, the instantaneous flow rate screen is displayed.

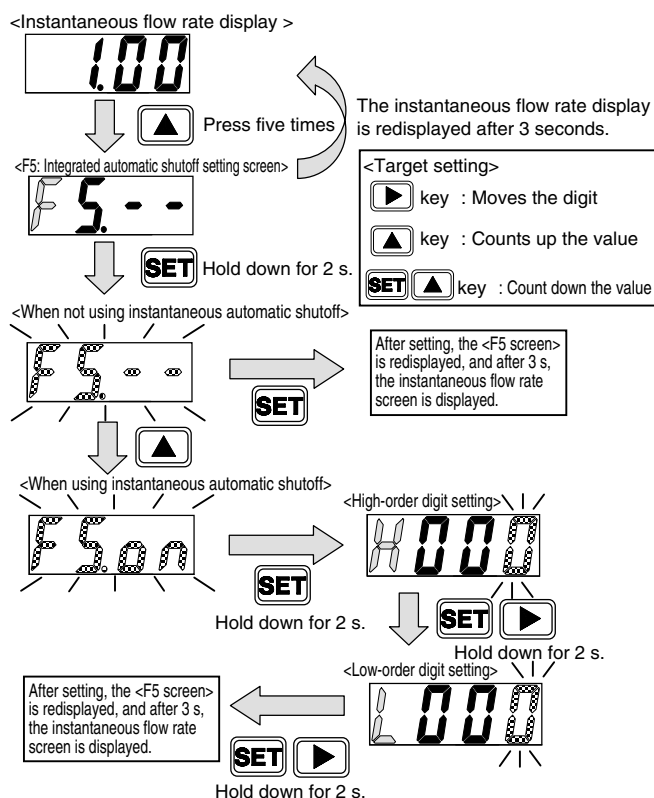

* Only in this mode, the integrated value is reset when the input signal reaches zero. (Valid only after automatic shutoff.)

* The solenoid valve is automatically shut off and the switch functions when the set integrated flow is reached.

* If the display for automatic shutoff is "OFF", the switch output lamp does not turn ON. The flow rate display is redisplayed when the integrated value is reset (button operation or external input).

* Even if automatic shutoff is invalidated during automatic shutoff, it does not function until the integrated value is reset.

* The integrated value is reset when automatic shutoff is set to "on" and the value is set.





Integrating the flow rate

(3) Outputting the integrated pulse (Only switch output)

The integrated pulse is output. Refer to the table on page 16 for the pulse rate.

Refer to the connection (page 5), examples of internal circuit and load connection (pages 6 and 7) for details on connecting switch output.

<Operation >

- (1) Instantaneous flow rate display
- (2) Press the  key four times and open the <F4: switch output setting screen>. If switch output setting is valid, "F4.□" and the current setting are alternately displayed. (The instantaneous flow rate display is displayed if 3 s pass without a button being pressed.)
- (3) Hold down the  key for 2 seconds, and enter switch output setting mode.
- (4) When the  key is pressed three times, "F4.3" blinks. When the  key is held down for 2 s, the integrated pulse output is set. The <F4 screen> is redisplayed, and after 3 s, the instantaneous flow rate screen is displayed.

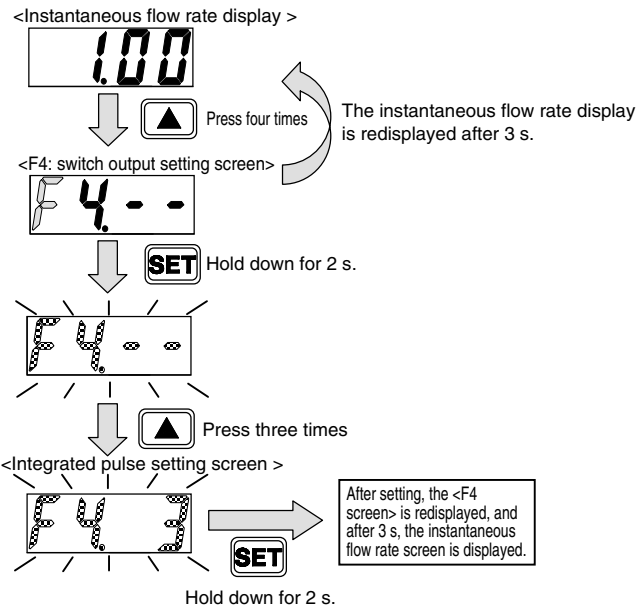









(4) Turning the set integrated flow ON with a switch (Only switch output)

Switch output is turned ON at the set integrated flow.

See the connection (page 5), examples of internal circuit and load connection (pages 6 and 7) for details on connecting switch output.

<Operation >

- (1) Instantaneous flow rate display
- (2) Press the  key four times and open the <F4: switch output setting screen>. If switch output setting is valid, "F4.□" and the current setting are alternately displayed. (The instantaneous flow rate display is displayed if 3 s pass without a button being pressed.)
- (3) Hold down the  key for 2 s, and enter switch output setting mode.
- (4) When the  key is pressed four times, "F4.4" blinks. Hold down the  key for 2 seconds, and open the target setting screen. After setting the high-order 3 digits of the target, hold down the  and  keys for 2 s. After setting the low-order 3 digits of the target, hold down the  and  keys for 2 s. The integrated value is reset after the target is set.
- (5) The <F5 screen> is displayed, and after 3 s, the instantaneous flow rate screen is displayed.

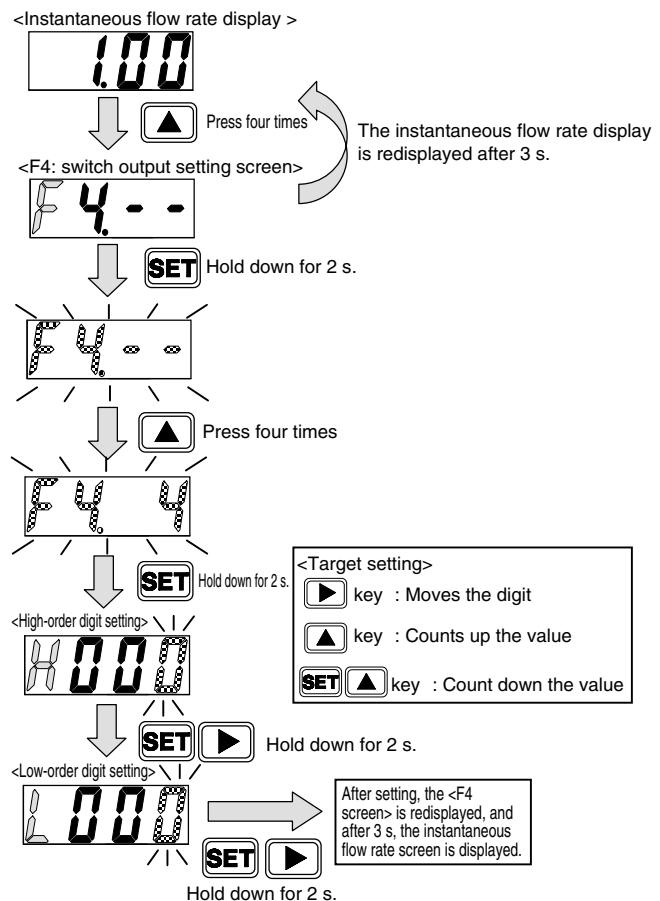

Using switch output (Only switch output)

(1) Using the tolerance mode

Switch output turns ON when the level is within the tolerance of the input signal setting.

The tolerance is set for both the plus side and minus side as a %FS (full-scale)

See the connection (page 5), examples of internal circuit and load connection (pages 6 and 7) for details on connecting switch output.

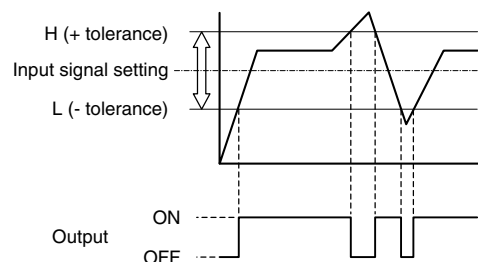

<Operation >

(1) Instantaneous flow rate display

(2) Press the key four times and open the <F4: switch output setting screen>. If switch output setting is valid, "F4.□" and the current setting are alternately displayed. (The instantaneous flow rate display is displayed if 3 s pass without a button being pressed.)

(3) Hold down the key for 2 s, and enter switch output setting mode.

(4) When the key is pressed once, "F4.1" blinks. Hold down the key for 2 s, and open the target setting screen.

(5) After setting the tolerance (minus side), hold down the and keys for 2 s.
Minus side setting range: -50 to 0% FS

(6) After setting the tolerance (plus side), hold down the and keys for 2 s.
Plus side setting range: 0 to 50% FS

(7) The <F4 screen> is redisplayed, and after 3 s, the instantaneous flow rate screen is displayed.

<Instantaneous flow rate display >

1.00

Press four times

<F4: switch output setting screen >

F4.□

Hold down for 2 s.

F4.□

Press once

F4.1

Hold down for 2 s.

<- tolerance setting (%)>

L - 00

Hold down for 2 s.

<+ tolerance setting (%)>

H 00

Hold down for 2 s.

<F4 screen>

F4.□

Hold down for 2 s.

After setting, the <F4 screen> is redisplayed, and after 3 seconds, the instantaneous flow rate screen is displayed.

The instantaneous flow rate display is redisplayed after 3 s.

<Target setting>

- key : Moves the digit
- key : Counts up the value
- key : Count down the value

Using switch output (Only switch output)

(2) Using the range designation mode

The switch turns ON when the level is not within the designated flow rate range. The upper and lower limit values are set regardless of the input signal setting (control target).

Both the upper limit and lower limit are set as % FS (full-scale).

Refer to the connection (page 5), examples of internal circuit and load connection (pages 6 and 7) for details on connecting switch output.

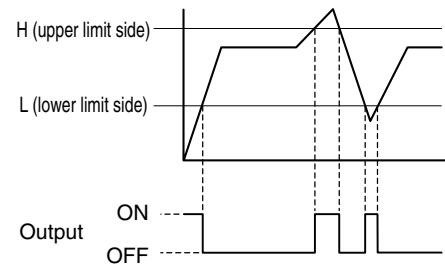

<Operation >

(1) Instantaneous flow rate display

(2) Press the key four times and open the <F4: switch output setting screen>. If switch output setting is valid, "F4.□" and the current setting are alternately displayed. (The instantaneous flow rate display is displayed if 3 s pass without a button being pressed.)

(3) Hold down the key for 2 s, and enter switch output setting mode.

(4) When the key is pressed twice, "F4.2" blinks. Hold down the key for 2 s, and open the target setting screen.

(5) After setting the lower limit value, hold down the and keys for 2 s.
Lower limit value setting range: 0 to 90% FS

(6) After setting the upper limit value, hold down the and keys for 2 s.
Upper limit value setting range: 10 to 100% FS
Note that the gap between the upper and lower limits must be 10% FS and over.

(7) The <F4 screen> is redisplayed, and after 3 s, the instantaneous flow rate screen is displayed.

<Instantaneous flow rate display >

1.00

Press four times

The instantaneous flow rate display is redisplayed after 3 s.

<F4: switch output setting screen >

F4.□

Hold down for 2 s.

F4.□

Press twice

F4.2

Hold down for 2 s.

F4.2

<Lower limit setting (%)>

00

Hold down for 2 s.

<Upper limit setting (%)>

100

Hold down for 2 s.

After setting, the <F4 screen> is redisplayed, and after 3 s, the instantaneous flow rate screen is displayed.

<Target setting>	
	key : Moves the digit
	key : Counts up the value
	key : Count down the value

Operation (List)

- Note:
- Keys are unlocked when the controller is shipped. Lock keys if necessary. The key lock/unlock state is held even if power is turned OFF.
 - Control does not stop during the F1: input signal selection or F2: input signal zero/span setting. Take safety into consideration and stop control (forced stop) if necessary.
 - The flow control/forced OFF state is held even if power is turned OFF.

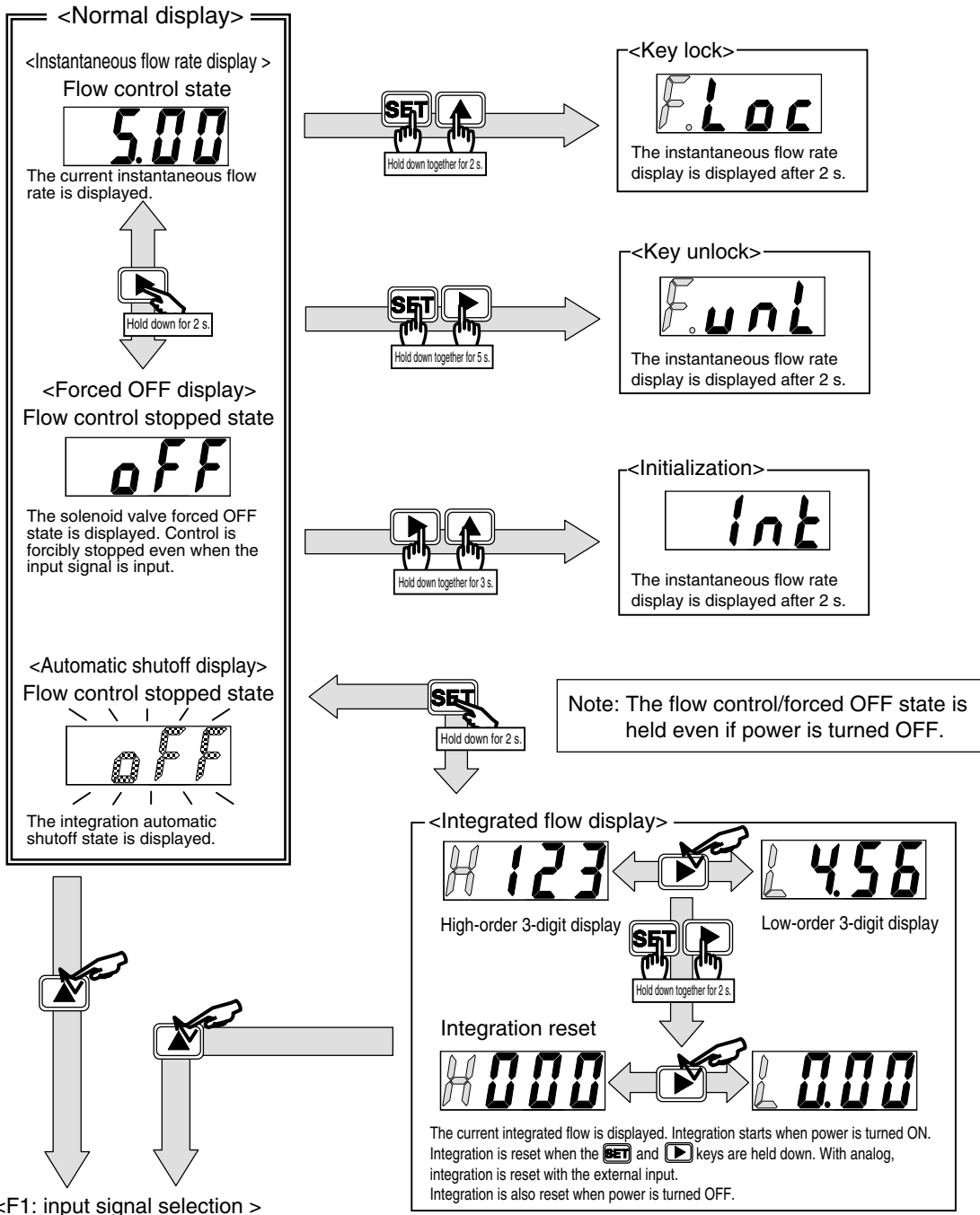

Operation (List)

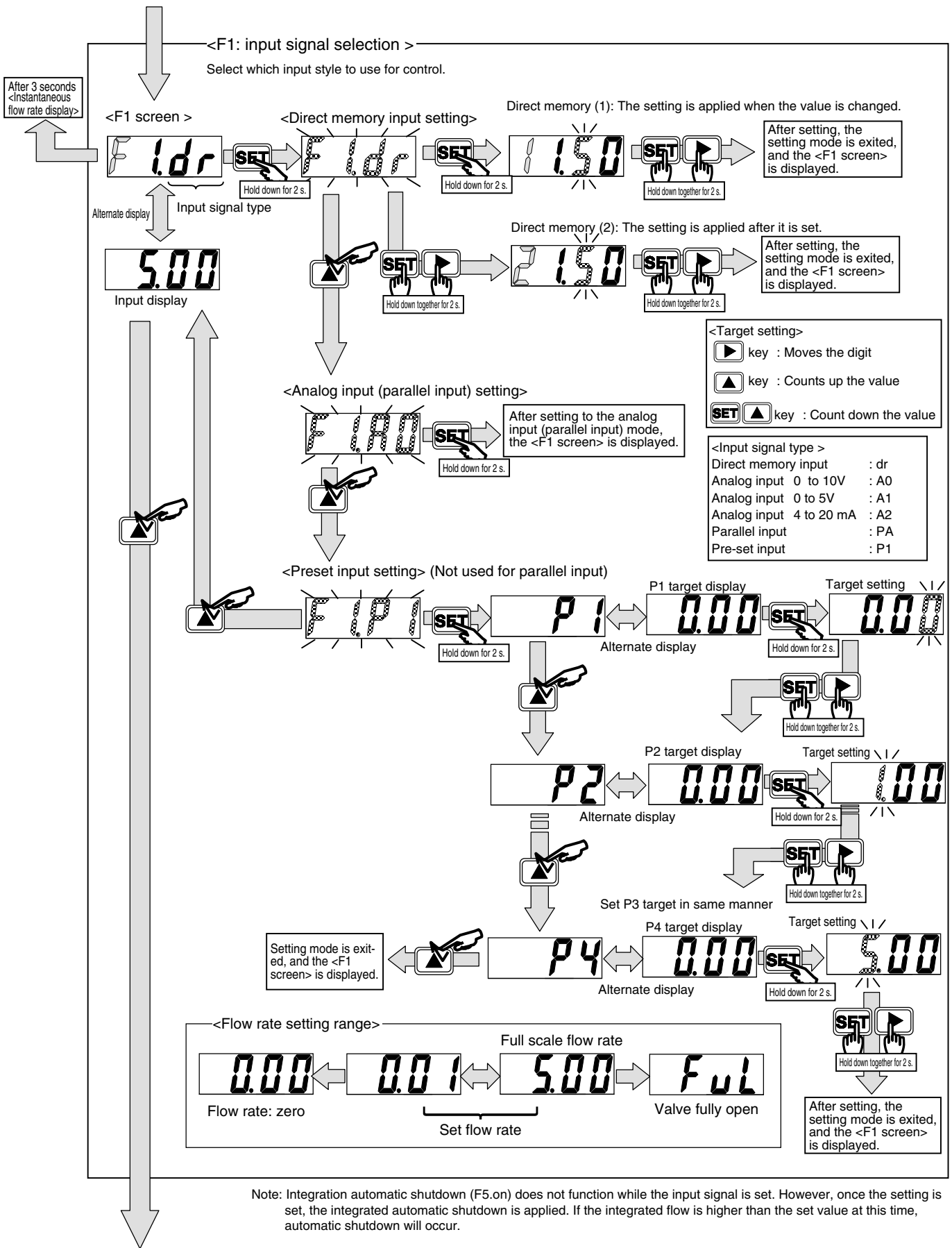

<F2: input signal zero span adjustment >

Operation (List)

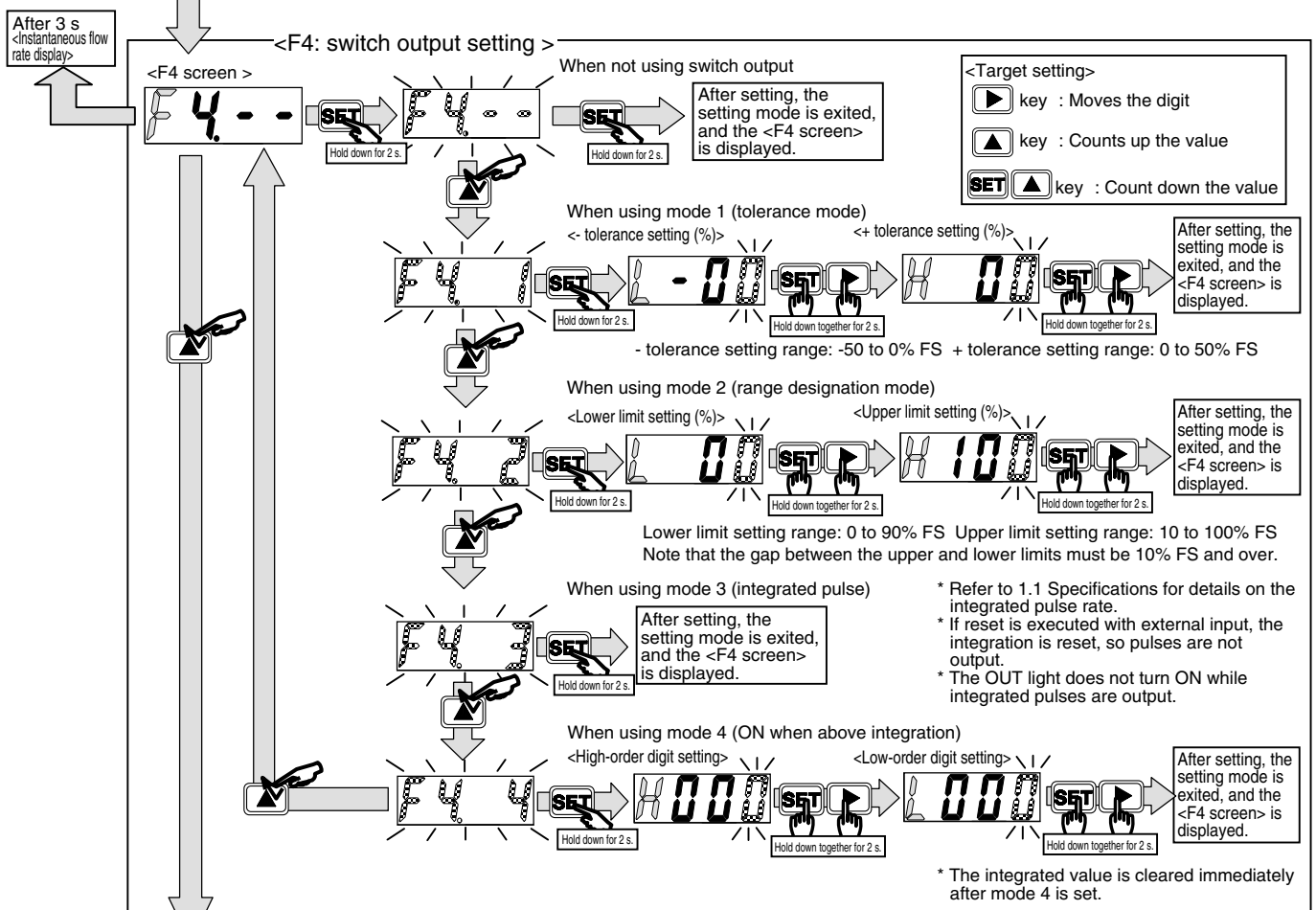
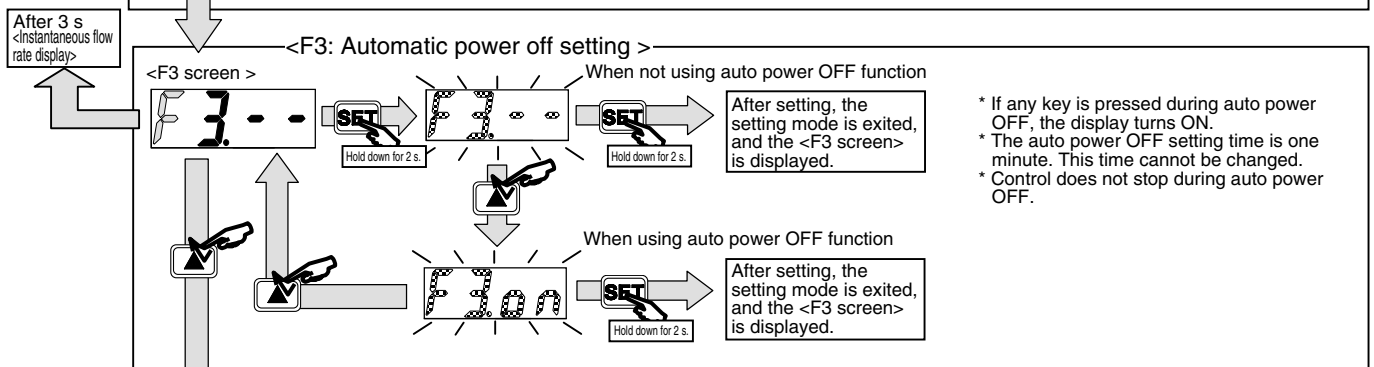
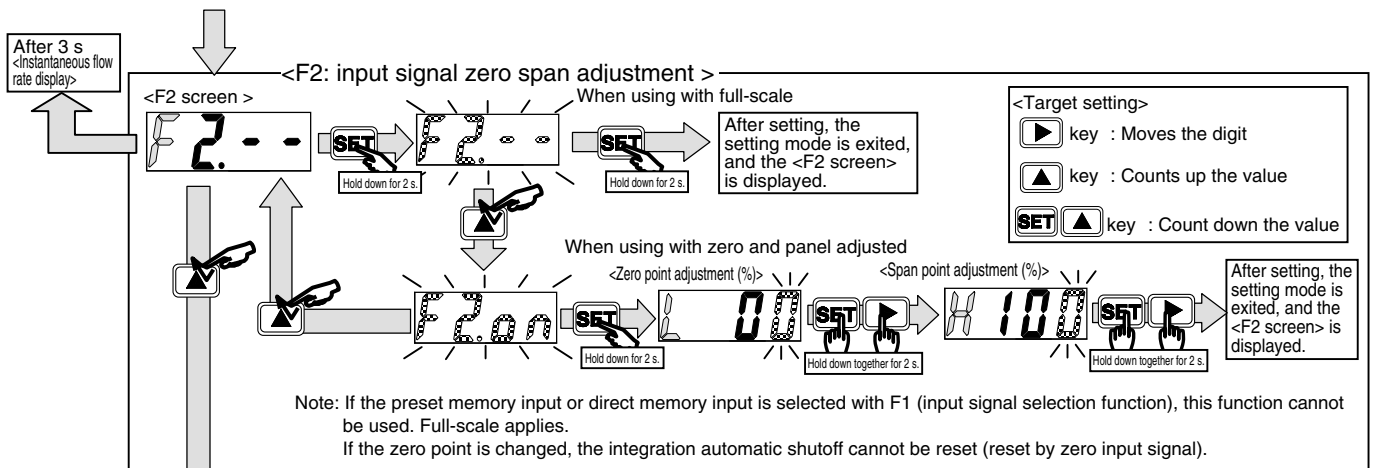

Note: Switch output setting mode cannot be entered with the analog output.

<F5: Integrated automatic shutoff setting screen>

Operation (List)

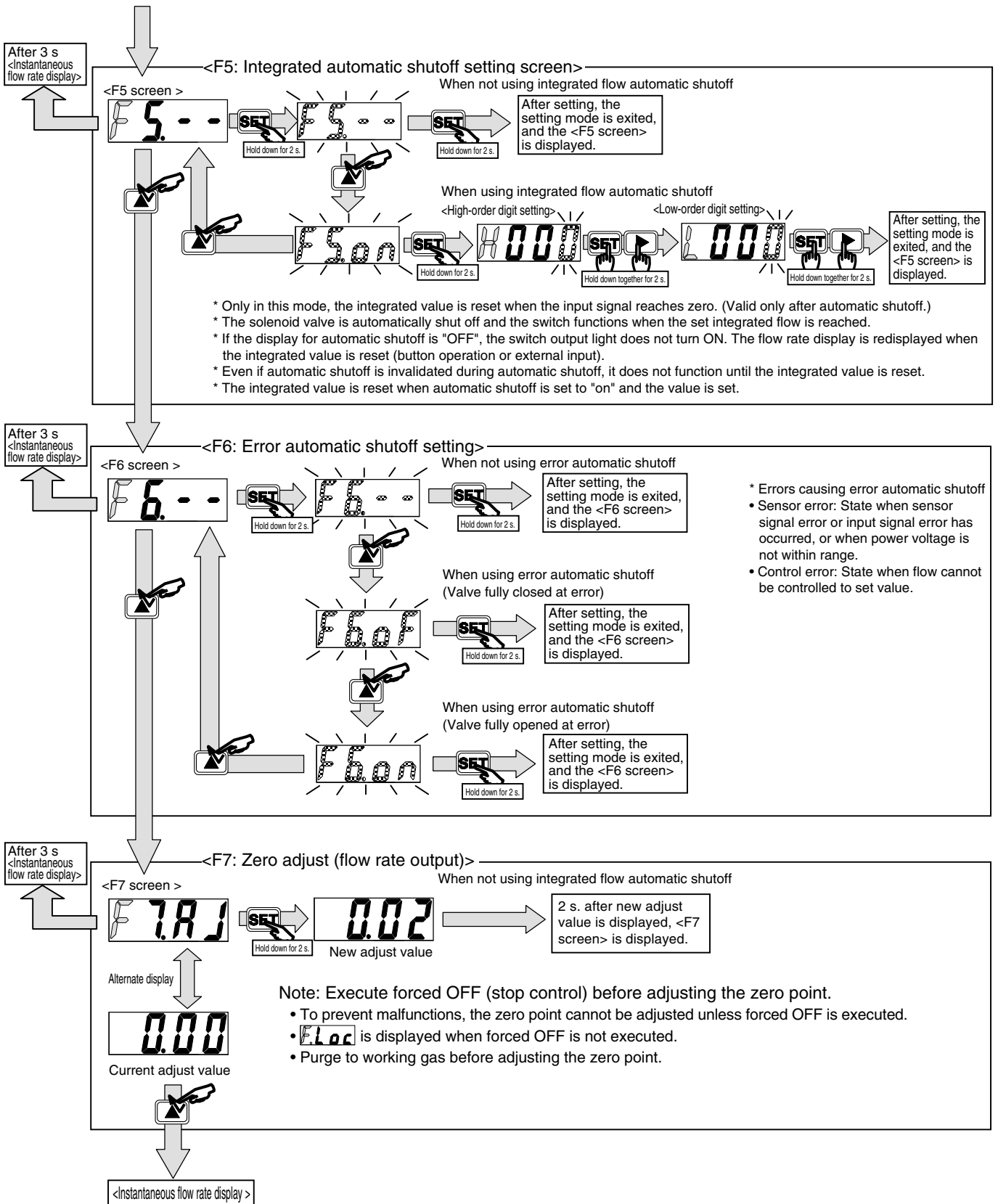

Custom-order Parts

Custom-order parts with the following functions are used. Contact the CKD Sales Office for details.

8-point preset input

This type is compatible with eight preset points. (Note that the external integration reset signal input cannot be used with this type.)

Oil-prohibition specifications (Only stainless steel body)

This option is available for stainless steel body (excluding oxygen models).

Related Products

Small size flow sensor FSM series

Three compact flow sensor series compatible with different applications

FSM-H series

- Compact, high-speed, extremely small flow
Detect extremely small flows of 1m ℓ /min or less at a high speed
- Positive/negative pressure types both used

FSM series

- Compact, high-speed response
- Compatible with argon (Ar) and carbon oxide (CO₂)

FSM-V series

- Ultra-compact, super high-speed response
Capable of 5 ms high-speed response

Catalog No. CC-687A



Inline Clean Filter FCS500/FCS1000 Series

Ideal as the final filter in different clean applications (For air and inert gas)

- 0.01 μm high filtration, 99.99% removal efficiency
A 0.01 μm filtration accuracy and 99.99% removal efficiency are attained with the hollow fiber membrane element.
- Long life
The greatly improved life is 5 times longer than the flat membrane type.
- Compact, lightweight, large flow
A filtration area 3 to 10 times larger than the flat membrane type with same capacity is adopted, enabling large flows to be processed with a low pressure loss. With the same capacity, the unit is downsized and lightened.
- Oil-prohibition specifications
All parts have been degreased and washed. All production from assembly to packaging is done in a clean room.
- Easy maintenance
The resin type has a transparent cover so element contamination is visually confirmed.
- Ample variations
The available variations include the 500 and 1000 flow rates, resin or stainless steel, and a push-in joint, male thread pipe or female thread pipe installation.

