

Stainless Steel

GS 2-WAY NEEDLE VALVES



GS G 1/2 DN13 S6000 316L/316L

Type and way of valve  
GS 2-way needle valves

Valves dimension of pressure(psi)

GAS	ANSI/ASME
DIN/ISO 228	B1.20.1 NPT
G 1/4	N 1/4
G 3/8	N 3/8
G 1/2	N 1/2
G 3/4	N 3/4
G 1"	N 1"
G 1"1/4	N 1"1/4
G 1"1/2	N 1"1/2

Nominal dimension

- DN6
- DN10
- DN13
- DN20
- DN25
- DN32
- DN40

Pressure

- S3000
- S6000

Body/Stem material

- 316L 1,4404
- 316L 1,4404

Specifications

- Type: needle valve GS 2way
- Body: square
- Material: 1,4404
- Ball seats: from DN6 up to DN40
- Operating pressure: S3000 (210 Bar) S6000 (350 Bar) depending on valve size and seal materials selected
- Temp range: -60°C to +230°C depending on seal material selected

"The company reserves the right to operate dimensional changes without prior notice".

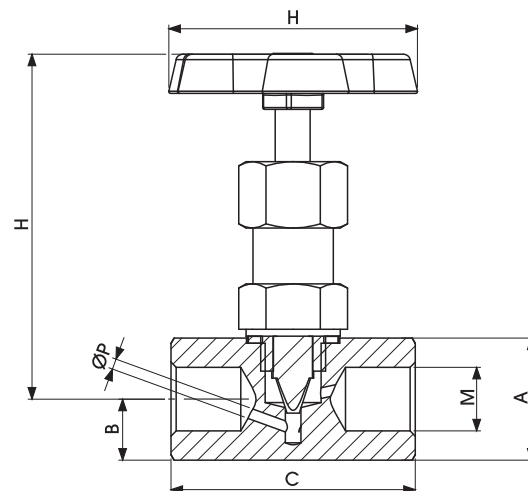

**GS DIN ISO 228  
S3000**
*Standard*

TYPE	PN	DN	A	B	C	H	I	M	ØP	Kg	ITEM CODE
GS G 1/4	21 MPa	6	30	15	61	70	100	G 1/4	5	0,55	BS2GGT1F044F000
GS G 3/8	21 MPa	10	30	15	61	70	100	G 3/8	6	0,55	BS2GGT2F044F000
GS G 1/2	21 MPa	13	35	17,5	70	70	100	G 1/2	8	0,75	BS2GGT3F044F000
GS G 3/4	21 MPa	20	40	20	78	80	115	G 3/4	9	1,1	BS2GGT4F044F000
GS G 1"	21 MPa	25	50	25	90	90	145	G 1"	11	2	BS2GGT5F044F000
GS G 1" 1/4	21 MPa	32	60	30	100	100	150	G 1" 1/4	15	2,5	BS2GGT6F044F000
GS G 1" 1/2	21 MPa	40	70	35	130	125	160	G 1" 1/2	19	3	BS2GGT7F044F000
GS G 2"	21 MPa	50	80	40	140	150	170	G 2"	22	3,5	BS2GGT8F044F000

**GS DIN ISO 228  
S6000**
*Standard*

TYPE	PN	DN	A	B	C	H	I	M	ØP	Kg	ITEM CODE
GS G 1/4	42 MPa	6	35	17,5	70	70	100	G 1/4	8	0,75	BS2GGT1G044F000
GS G 3/8	42 MPa	10	35	17,5	70	70	100	G 3/8	8	0,75	BS2GGT2G044F000
GS G 1/2	42 MPa	13	40	20	78	80	115	G 1/2	9	1,1	BS2GGT3G044F000
GS G 3/4	42 MPa	20	50	25	90	90	145	G 3/4	11	2	BS2GGT4G044F000
GS G 1"	42 MPa	25	60	30	100	100	150	G 1"	15	2,5	BS2GGT5G044F000
GS G 1" 1/4	42 MPa	32	70	35	130	125	160	G 1" 1/4	19	3	BS2GGT6G044F000
GS G 1" 1/2	42 MPa	40	80	40	140	130	170	G 1" 1/2	22	3,5	BS2GGT7G044F000

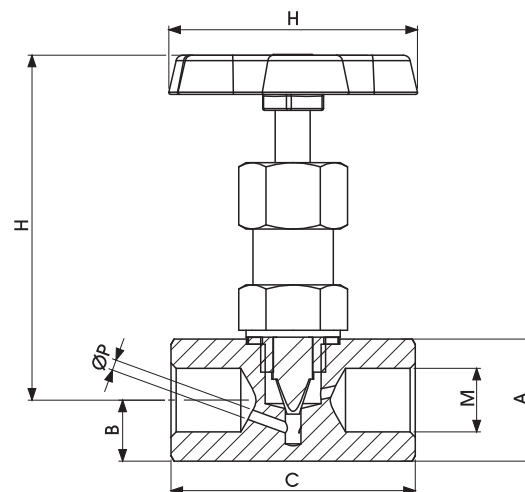
"The company reserves the right to operate dimensional changes without prior notice".



**GS ANSI ASME B1.20.1  
S3000**

Standard

TYPE	PN	DN	A	B	C	H	I	M	ØP	Kg	ITEM CODE
GS N 1/4	21 MPa	6	30	15	61	70	100	N 1/4	5	0,55	BS2NNT1F044F000
GS N 3/8	21 MPa	10	30	15	61	70	100	N 3/8	6	0,55	BS2NNT2F044F000
GS N 1/2	21 MPa	13	35	17,5	70	70	100	N 1/2	8	0,75	BS2NNT3F044F000
GS N 3/4	21 MPa	20	40	20	78	80	115	N 3/4	9	1,1	BS2NNT4F044F000
GS N 1"	21 MPa	25	50	25	90	90	145	N 1"	11	2	BS2NNT5F044F000
GS N 1" 1/4	21 MPa	32	60	30	100	100	150	N 1" 1/4	15	2,5	BS2NNT6F044F000
GS N 1" 1/2	21 MPa	40	70	35	130	125	160	N 1" 1/2	19	3	BS2NNT7F044F000
GS N 2"	21 MPa	50	80	40	140	150	170	N 2"	22	3,5	BS2NNT8F044F000

**GS ANSI ASME B1.20.1  
S6000**

Standard

TYPE	PN	DN	A	B	C	H	I	M	ØP	Kg	ITEM CODE
GS N 1/4	42 MPa	6	35	17,5	70	70	100	N 1/4	8	0,75	BS2NNT1G044F000
GS N 3/8	42 MPa	10	35	17,5	70	70	100	N 3/8	8	0,75	BS2NNT2G044F000
GS N 1/2	42 MPa	13	40	20	78	80	115	N 1/2	9	1,1	BS2NNT3G044F000
GS N 3/4	42 MPa	20	50	25	90	90	145	N 3/4	11	2	BS2NNT4G044F000
GS N 1"	42 MPa	25	60	30	100	100	150	N 1"	15	2,5	BS2NNT5G044F000
GS N 1" 1/4	42 MPa	32	70	35	130	125	160	N 1" 1/4	19	3	BS2NNT6G044F000
GS N 1" 1/2	42 MPa	40	80	40	140	130	170	N 1" 1/2	22	3,5	BS2NNT7G044F000

"The company reserves the right to operate dimensional changes without prior notice".

## GS 2-WAY NEEDLE VALVES

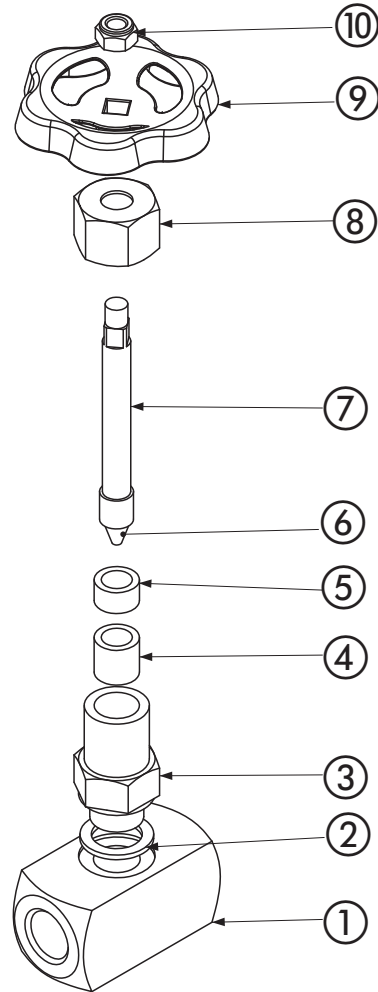

Pos	Description	Material	Q.tà
1	Body	1,4404	1
2	Gasket	GLINGERITE	1
3	Bonnet	1,4404	1
4	Gland	GRAPHITE	1
5	Gland press	1,4404	1
6	Wedge	1,4404	1
7	Stem	1,4404	1
8	Packing nut	DIN6921 A2	1
9	Handle	1,0116	1
10	Nut	DIN6921 A2	1

### On request

- Special Threads

• For further special requests please consult our technical/commercial service

"The company reserves the right to operate dimensional changes without prior notice".