

HySense® – Sensors for all applications

HySense is the new name for all sensors made by Hydrotechnik. It is synonymous with quality without compromise and with unlimited reliability.

Many features are integrated into the new names, as shown below:

The new systematic naming of the sensors indicates the sensor type.

PR 100

Measurand

The two letters at the beginning of the model name indicate the sensor type:

PR	pressure	QL	load valves
PS	pressure switch	RS	rotational speed
TE	temperature	TQ	torque
TP	pressure and temperature	PO	position
QG	volume flow (gear)	FO	force
QT	volume flow (turbine)	VB	vibration
QO	volume flow (oval wheel)	AC	accessories

Model series

The first digit of the model name indicates the model series. The current model series are numbered consecutively starting with 1.

Measurand-specific identifier

The second digit of the model name is reserved for an identifier that indicates either the type of the connecting plug (for all sensors, except volume flow sensors), or the output signal of the sensor (for volume flow sensors).

The coding is shown at the beginning of each section of this catalogue.

Special versions

The third digit of the model name indicates special versions of the sensor:

5	explosion-proof
6	CAN output signal
7	high-temperature
8	increased IP protection
9	DESINA conform version

Pressure is a central factor in fluid technology. By measuring the pressure, basic settings in systems and installations can be made and it is also very important for diagnosis of the complete system.

Hydrotechnik offers a broad range of piezo-resistive sensors where the deformation of a metal membrane

influences electrical resistance which can be used to determine pressure values and dynamic changes.

The offered sensors are separated into three product families:



HySense PR 1xx (former product name HT-PD)

Proven standard sensors for industrial use, equipped with a measuring cell made of high-grade steel. Special versions for explosive environments, with increased IP protection and CAN output signal.



HySense PR 2xx

High-precision sensor with very small dimensions. Ideal for all applications with reduced installation space.



HySense PR 3xx (former product name PR 15)

Our top model for measuring tasks requiring the highest accuracy. We use a piezo-resistive silicon chip protected from environmental influences by a high-grade steel casing. A thin flexible metal membrane in the casing separates the transmission fluid from the medium.

Connector versions

The second digit of the model name indicates the connector type:

0	6 pole device connector, M16 x 0,75
1	5 pole device connector, M16 x 0,75
2	5 pole device connector, M12 x 1
3	4 pole device connector, M12 x 1
4	4 pole device connector, EN 175301-803 type A, Pg9
5	4 pole device connector, EN 175301-803 type C, Pg7
8	other connector versions
9	open wires

HySense PR 130*

4 pole device connector, M12 x 1



Dimensions

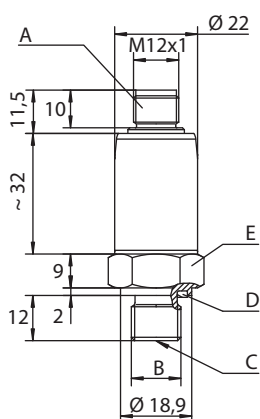

- A 4 pole device connector
- B ISO 228 – G $\frac{1}{4}$ A
- C Restrictor insert \varnothing 0.6 for measuring ranges > 0 ... 60 bar (0 ... 6.0 MPa)
- D Profile seal acc. to DIN 3869, FKM
- E SW 22

Qualities

Measuring principle	piezo-resistive (poly-cristalline silicon thin film structure on high-grade steel membrane)
Pressure type	relative pressure
Output signal	4 ... 20 mA / 0 ... 10 VDC
Electrical measuring connector	4 pole device connector, M12 x 1
Mechanical connection thread	ISO 228 – G $\frac{1}{4}$ A
Sealing material	profile seal ring acc. to DIN 3869, FKM
Protection type (EN 60529 / IEC 529)	IP 67 (when connector is screwed)
Casing material	non-corrosive high-grade steel
Membrane material	non-corrosive high-grade steel
Tightening torque	40 Nm (\pm 5 Nm)
Weight	~ 85 g

Pin assignment



Pin assignment	4 ... 20 mA (two wires)	0 ... 10 V (three wires)
1	+ Ub / signal +	+ Ub
2	free	free
3	- Ub / signal -	- Ub / signal - / GND
4	free	Signal +

Measuring range		Order number	
bar	MPa	4 ... 20 mA	0 ... 10 V
-1 ... 6	-0.1 ... 0.6	3403-32-I5.37S	3403-32-I5.39S
0 ... 10	0 ... 1.0	3403-26-I5.37S	3403-26-I5.39S
0 ... 25	0 ... 2.5	3403-40-I5.37S	3403-40-I5.39S
0 ... 60	0 ... 6.0	3403-21-I5.37S	3403-21-I5.39S
0 ... 100	0 ... 10	3403-16-I5.37S	3403-16-I5.39S
0 ... 250	0 ... 25	3403-17-I5.37S	3403-17-I5.39S
0 ... 400	0 ... 40	3403-15-I5.37S	3403-15-I5.39S
0 ... 600	0 ... 60	3403-18-I5.37S	3403-18-I5.39S
0 ... 1.000	0 ... 100	3403-29-I5.37S	3403-29-I5.39S

Common technical data on page 14. Further output signals on request.
Measuring ranges > 1000 ... 4000 bar (100 ... 400 MPa) on request.

*: former product name HT-PD

HySense PR 140*

4 pole device connector, DIN EN 175301-803 type A, Pg9



Dimensions

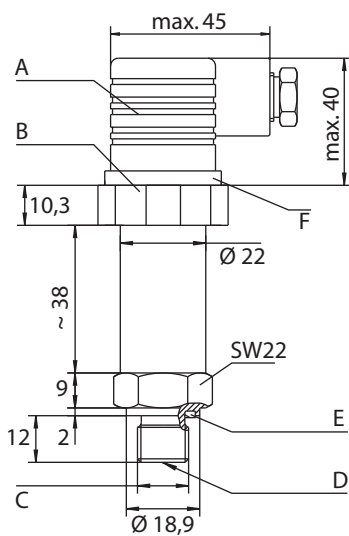

- A Contact box, Typ EN 175301-803, type A
 B Device connector SW 33,5
 C ISO 228 – G $\frac{1}{4}$ A
 D Restrictor insert \varnothing 0.6 for measuring ranges > 0 ... 60 bar (0 ... 6.0 MPa)
 E Profile seal acc. to DIN 3869, FKM
 F Profile seal

Qualities

Measuring principle	piezo-resistive (poly-crystalline silicon thin film structure on high-grade steel membrane)
Pressure type	relative pressure
Output signal	4 ... 20 mA / 0 ... 10 VDC
Electrical measuring connector	4 pole device connector, DIN EN 175301-803, type A, Pg9
Mechanical connection thread	ISO 228 – G $\frac{1}{4}$ A
Sealing material	profile seal ring acc. to DIN 3869, FKM
Protection type (EN 60529 / IEC 529)	IP 65 (with connecting cable \varnothing 6 ... 8 mm)
Casing material	non-corrosive high-grade steel
Membrane material	non-corrosive high-grade steel
Tightening torque	40 Nm (\pm 5 Nm)
Weight	~ 117 g

Pin assignment

	4 ... 20 mA (two wires)	0 ... 10 V (three wires)
	1 + Ub / signal +	1 + Ub
	2 – Ub / signal –	2 – Ub / signal – / GND
	3 free	3 Signal +

Measuring ranges		Order number	
bar	MPa	4 ... 20 mA	0 ... 10 V
-1 ... 6	-0.1 ... 0.6	3403-32-D1.37S	3403-32-D1.39S
0 ... 10	0 ... 1.0	3403-26-D1.37S	3403-26-D1.39S
0 ... 25	0 ... 2.5	3403-40-D1.37S	3403-40-D1.39S
0 ... 60	0 ... 6.0	3403-21-D1.37S	3403-21-D1.39S
0 ... 100	0 ... 10	3403-16-D1.37S	3403-16-D1.39S
0 ... 250	0 ... 25	3403-17-D1.37S	3403-17-D1.39S
0 ... 400	0 ... 40	3403-15-D1.37S	3403-15-D1.39S
0 ... 600	0 ... 60	3403-18-D1.37S	3403-18-D1.39S
0 ... 1.000	0 ... 100	3403-29-D1.37S	3403-29-D1.39S

Common technical data on page 14. Further output signals on request.
 Measuring ranges > 1000 ... 4000 bar (100 ... 400 MPa) on request.

*: former product name HT-PD



HySense PR 150*

4 pole device connector, DIN EN 175301-803 type C, Pg7



Dimensions

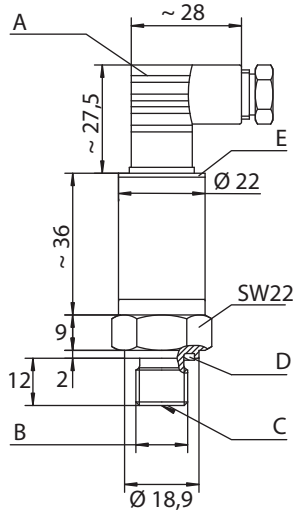

- A 4 pole device connector, Typ EN 175301-803, type C
- B ISO 228 – G $\frac{1}{4}$ A
- C Restrictor insert \varnothing 0.6 for measuring ranges > 0 ... 60 bar (0 ... 6.0 MPa)
- D Profile seal acc. to DIN 3869, FKM
- E Profile seal

Qualities

Measuring principle	piezo-resistive (poly-cristalline silicon thin film structure on high-grade steel membrane)
Pressure type	relative pressure
Output signal	4 ... 20 mA / 0 ... 10 VDC
Electrical measuring connector	4 pole device connector, DIN EN 175301-803, type C, Pg7
Mechanical connection thread	ISO 228 – G $\frac{1}{4}$ A
Sealing material	profile seal ring acc. to DIN 3869, FKM
Protection type (EN 60529 / IEC 529)	IP 65 (with connecting cable \varnothing 4,5 ... 6 mm)
Casing material	non-corrosive high-grade steel
Membrane material	non-corrosive high-grade steel
Tightening torque	40 Nm (\pm 5 Nm)
Weight	~ 97 g

Pin assignment

	4 ... 20 mA (two wires)	0 ... 10 V (three wires)
3	+ Ub / signal +	+ Ub
2	- Ub / signal -	- Ub / signal - / GND
1	free	Signal +

Measuring ranges		Order number	
bar	MPa	4 ... 20 mA	0 ... 10 V
-1 ... 6	-0.1 ... 0.6	3403-32-D5.37S	3403-32-D5.39S
0 ... 10	0 ... 1.0	3403-26-D5.37S	3403-26-D5.39S
0 ... 25	0 ... 2.5	3403-40-D5.37S	3403-40-D5.39S
0 ... 60	0 ... 6.0	3403-21-D5.37S	3403-21-D5.39S
0 ... 100	0 ... 10	3403-16-D5.37S	3403-16-D5.39S
0 ... 250	0 ... 25	3403-17-D5.37S	3403-17-D5.39S
0 ... 400	0 ... 40	3403-15-D5.37S	3403-15-D5.39S
0 ... 600	0 ... 60	3403-18-D5.37S	3403-18-D5.39S
0 ... 1.000	0 ... 100	3403-29-D5.37S	3403-29-D5.39S

Common technical data on page 14. Further output signals on request.
Measuring ranges > 1000 ... 4000 bar (100 ... 400 MPa) on request.

*: former product name HT-PD



Dimensions

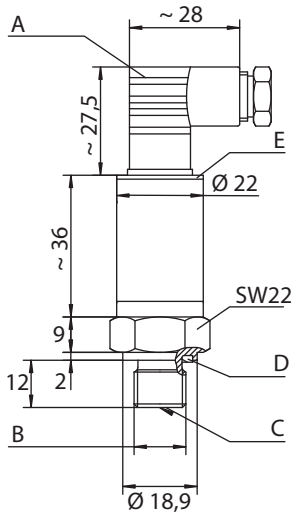

- A 4 pole device connector EN 175301-803, type C
 B ISO 228 – G¼ A
 C Restrictor insert Ø 0.6 for measuring ranges
 > 0 ... 60 bar (0 ... 6.0 MPa)
 D Profile seal acc. to DIN 3869, FKM
 E Profile seal

Qualities

Measuring principle	piezo-resistive (poly-crystalline silicon thin film structure on high-grade steel membrane)
Pressure type	relative pressure
Output signal	4 ... 20 mA
Electrical measuring connector	4 pole device connector, DIN EN 175301-803, type C, Pg7
Mechanical connection thread	ISO 228 – G ¼ A
Sealing material	Profile seal ring acc. to DIN 3869, FKM
Protection type (EN 60529 / IEC 529)	IP 65 (with connecting cable Ø 4.5 ... 6 mm)
Casing material	non-corrosive high-grade steel
Membrane material	non-corrosive high-grade steel
Tightening torque	40 Nm (± 5 Nm)
Weight	~ 100 g
Ex-approval	Ex II 2G
Explosion protection	EEx ia IIC T4
Approval number	IBExU 06 ATEX 1159

Pin assignment

4 ... 20 mA (two wires)

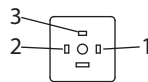

- 1 free
 2 – Ub / signal – / GND
 3 + Ub / signal +

Measuring range		Order number
bar	MPa	4 ... 20 mA
-1 ... 1	-0.1 ... 0.1	3X03-20-03.37
0 ... 25	0 ... 2.5	3X03-40-03.37
0 ... 60	0 ... 6.0	3X03-21-03.37
0 ... 100	0 ... 10	3X03-16-03.37
0 ... 250	0 ... 25	3X03-17-03.37
0 ... 400	0 ... 40	3X03-15-03.37
0 ... 600	0 ... 60	3X03-18-03.37
0 ... 1.000	0 ... 100	3X03-29-03.37

Common technical data on page 14. Further output signals on request.
 Measuring ranges > 1000 ... 2000 bar (100 ... 200 MPa) on request.

HySense PR 190*

Open cable ends, 4 wire



Dimensions

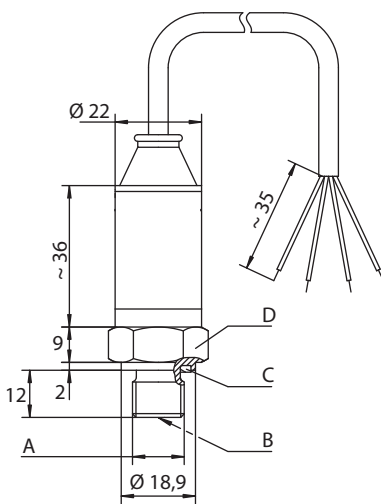

- A ISO 228 – G $\frac{1}{4}$ A
- B Restrictor insert \varnothing 0.6 for measuring ranges > 0 ... 60 bar (0 ... 6.0 MPa)
- C Profile seal acc. to DIN 3869, FKM
- D SW 22

Qualities

Measuring principle	piezo-resistive (poly-cristalline silicon thin film structure on high-grade steel membrane)
Pressure type	relative pressure
Output signal	4 ... 20 mA / 0 ... 10 VDC
Electrical measuring connector	open ends, 4 wires, connection cable 1.5 m
Mechanical connection thread	ISO 228 – G $\frac{1}{4}$ A
Sealing material	profile seal ring acc. to DIN 3869, FKM
Protection type (EN 60529 / IEC 529)	IP 68 K
Casing material	non-corrosive high-grade steel
Membrane material	non-corrosive high-grade steel
Tightening torque	40 Nm (\pm 5 Nm)
Weight	\sim 120 g

Wire assignment

Wire color	4 ... 20 mA (two wires)	0 ... 10 V (three wires)
white	free	Signal +
black	– Ub / signal –	– Ub / signal – / GND
green	free	free
red	+ Ub / signal +	+ Ub

Measuring range		Order number	
bar	MPa	4 ... 20 mA	0 ... 10 V
-1 ... 6	-0.1 ... 0.6	3403-32-D6.37S	3403-32-D6.39S
0 ... 10	0 ... 1.0	3403-26-D6.37S	3403-26-D6.39S
0 ... 25	0 ... 2.5	3403-40-D6.37S	3403-40-D6.39S
0 ... 60	0 ... 6,0	3403-21-D6.37S	3403-21-D6.39S
0 ... 100	0 ... 10	3403-16-D6.37S	3403-16-D6.39S
0 ... 250	0 ... 25	3403-17-D6.37S	3403-17-D6.39S
0 ... 400	0 ... 40	3403-15-D6.37S	3403-15-D6.39S
0 ... 600	0 ... 60	3403-18-D6.37S	3403-18-D6.39S
0 ... 1.000	0 ... 100	3403-29-D6.37S	3403-29-D6.39S

Common technical data on page 14. Further output signals on request.
Measuring ranges > 1000 ... 4000 bar (100 ... 400 MPa) on request.

*: former product name HT-PD

Common technical data

The technical data shown here is valid for the sensors in the HySense® PR 1xx range, mentioned on the previous pages:

- PR 130
- PR 140
- PR 150
- HT-PDX-20 (PR 155)
- PR 190

Technical data	PR 130 / PR 140 / PR 150 / PR 190	HT-PDX-20
Overload range	1.5 x nominal pressure	
Burst pressure	3 x nominal pressure	
Signal type	Two wire analog (4 ... 20 mA), three wire analog (0 ... 10 VDC)	
Supply voltage U_b		
... at 4 ... 20 mA	10 ... 30 VDC	30 V
... at 0 ... 10 VDC	12 ... 32 VDC	–
Current consumption	6.5 mA	50 mA
Overvoltage protection	32 VDC	
Error limit (of final value)	comprises the influences non-linearity, hysteresis, repeatability, zero-point- and span error	
... at +22 °C (room temperature)	± 0.5 %	
... at -15 ... +85 °C	< ± 1.0 %	
... at +85 ... +100 °C	< ± 2.5 %	
... at -40 ... -15 °C	< ± 2.5 %	
Temperature error (-20 ... +80 °C)	< ± 0,03 %/°C	
Compensation temperature range	-40 ... +100 °C	
Non-linearity	< ± 0.4 % of final value	
Reproducibility	< ± 0.1 % of final value	
Hysteresis	< ± 0.1 % of final value	
Long-term stability	< ± 0.1 % of final value/year	
Response time	< = 1 ms (10 ... 90 %)	
Frequency range	< = 1 kHz	
Isolation resistance	min. 100 MΩ	
Total resistance	$R_g = (U_b - 10 V) / 20 \text{ mA}$ (at output signal 4 ... 20 mA)	
Load resistance	$R_L = > 5 \text{ k}\Omega$ (at output signal 0 ... 10 VDC)	
Number of load cycles	> 10×10^6	
Medium temperature	-40 ... +125 °C	
Environmental temperature	-40 ... +105 °C (short term +125 °C)	-40 ... +85 °C
Storage temperature	-40 ... +125 °C	
EMV test	EN 50081-2, EN 50082-2	
Vibrational stability	5 mm 10 ... 32 Hz, 20 g 32 ... 500 Hz, DIN EN 60068-2-6	
Shock stability	50 g (11 ms half-sine)	
Mounting orientation	arbitrary	



5 pole device connector, M12 x 1



Dimensions

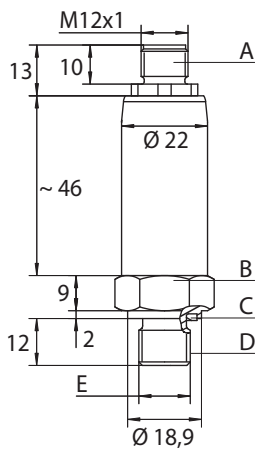

- A 5 pole device connector, M12 x 1
- B SW 22
- C Profile seal ring acc. to DIN 3869, FKM
- D Restrictor insert $\varnothing 0.6$
- E ISO 228 G $\frac{1}{4}$ A

Qualities

Measuring principle	piezo-resistive (poly-cristalline silicon thin film structure on high-grade steel membrane)
Pressure type	relative pressure
Output signal	CANopen
Electrical measuring connector	5 pole device connector, M12 x 1
Mechanical connection thread	ISO 228 – G $\frac{1}{4}$ A
Sealing material	profile seal ring acc. to DIN 3869, FKM
Protection type (EN 60529 / IEC 529)	IP 67 (with screwed connector)
Casing material	non-corrosive high-grade steel
Membrane material	non-corrosive high-grade steel
Tightening torque	40 Nm (± 5 Nm)
Weight	~ 100 g
CAN bus	LSS slave function
Baud rate	10 ... 500 kBaud (settable)
CAN interface	acc. to DIN 11898

Pin assignment

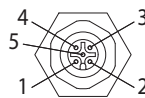

CANopen

- 1 CAN_SHLD
- 2 CAN_V+
- 3 CAN_GND
- 4 CAN_H
- 5 CAN_L

Measuring range

Order number

bar	MPa	CANopen
0 ... 100	0 ... 10	3403-16-D2.60
0 ... 400	0 ... 40	3403-15-D2.60
0 ... 600	0 ... 60	3403-18-D2.60

*: former product name HT-PD

Technical data

Technical data	PR 126
Overload range	2 x nominal pressure
Burst pressure	3 x nominal pressure
Signal type	CANopen, digital
Supply voltage U_b	12 ... 27 VDC
Current consumption	10 ... 30 mA, depends on CAN bus load
Overvoltage protection	± 40 VDC
Error limit (of final value)	comprises the influences non-linearity, hysteresis, repeatability, zero-point- and span error
... at +22 °C (room temperature)	± 0.5 %
... at -15 ... +85°C	± 0.5 %
... at +85 ... +100°C	± 1.0 %
... at -40 ... -15°C	± 1.0 %
Compensation temperature range	-15 ... +85 °C
Non-linearity	$< \pm 0.2$ % of final value
Reproducibility	$< \pm 0.1$ % of final value
Hysteresis	$< \pm 0.1$ % of final value
Long-term stability	$< \pm 0.1$ % of final value/year
Response time	$< = 1$ ms (0 ... 90 %)
Frequency range	$< = 1$ kHz
Isolation resistance	> 100 MOhm
Number of load cycles	1×10^7
Medium temperature	-40 ... +105 °C
Environmental temperature	-40 ... +105 °C
Storage temperature	-40 ... +125 °C
EMV test	EN 50081-2 and EN 50082-2
Vibrational stability	IEC 68-2-6 and IEC 68-2-36, 20 g
Mounting orientation	arbitrary

HySense PR 280

Miniature pressure sensor

This sensor is ideal for applications where very low weight and minimized dimensions are required (e.g. in regulating valves).

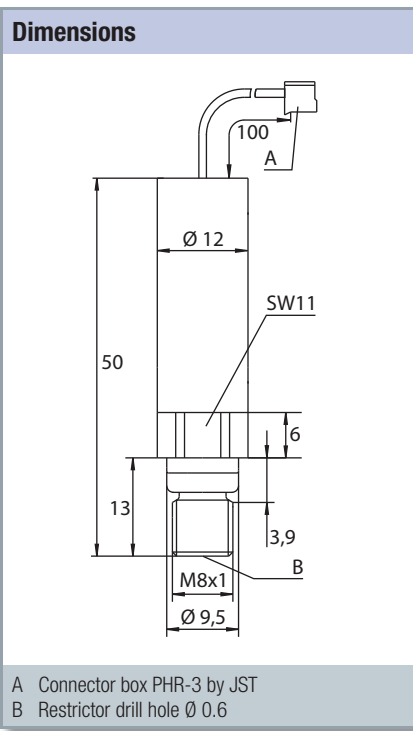

Qualities	
Measuring principle	piezo-resistive (poly-cristalline silicon thin film structure on high-grade steel membrane)
Pressure type	relative pressure
Output signal	0.5 ... 4.5 VDC
Electrical measuring connector	connector box JST PHR-3
Mechanical connection thread	M8 x 1
Sealing material	O ring FKM
Protection type (EN 60529 / IEC 529)	IP 00
Casing material	1.4571
Membrane material	non-corrosive high-grade steel
Tightening torque	8 Nm (± 2 Nm)
Weight	~ 22 g

Pin assignment

Connector box PHR-3	0.5 ... 4.5 V DC (three wires)
	Pin 1 = Ub
	Pin 2 = GND
	Pin 3 = signal

Ø D	Measuring range		Order number
	bar	MPa	
mm			0.5 ... 4.5 V DC
15	0 ... 20	0 ... 2	34B3-27-03.49
12	0 ... 100	0 ... 10	34B3-16-03.49
	0 ... 160	0 ... 16	34B3-19-03.49
	0 ... 250	0 ... 25	34B3-17-03.49
	0 ... 400	0 ... 40	34B3-15-03.49

Due to EMC requirements, it is necessary to install the sensor in a capsuled metal casing.

Technical data

Technical data	PR 280
Overload range	2 x nominal pressure
Burst pressure	4 x nominal pressure
Signal type	three wire
Supply voltage U_b	12 ... 30 VDC
Current consumption	< 10 mA
Error limit (of final value)	comprises the influences non-linearity, hysteresis, repeatability, zero-point- and span error
... at +22 °C (room temperature)	± 0.5 %
... at -15 ... +85 °C	± 0.5 %
... at +85 ... +100 °C	± 1.0 %
... at -40 ... -15 °C	± 1.0 %
Compensation temperature range	0 ... +80 °C
Non-linearity	< ± 0.2 % of final value
Reproducibility	< ± 0.05 % of final value
Hysteresis	< ± 0.1 % of final value
Long-term stability	< ± 0.2 % of final value/year
Response time	< = 1 ms
Frequency range	> 1 kHz
Isolation resistance	> 100 MΩ
Load resistance	2.3 kΩ
Number of load cycles	> 1 x 10 ⁷
Medium temperature	-20 ... +90 °C
Environmental temperature	-40 ... +125 °C
Storage temperature	-40 ... +140 °C
EMV test	DIN EN 61000-4-2 / -3 / -4 / -6 / -8
Vibrational stability	1 mm oscillation way (10 ... 50 Hz) 20 g (20 ... 2,000 Hz)
Shock stability	50 g (6 ms half-sine)
Mounting orientation	arbitrary