



HySense QG 100* / QG 110*



Gear volume flow sensor

QG



Delivery with f/l-converter for output signal 4...20 mA***

Qualities	
Measuring principle	displacement
Viscosity range	10 ... 500 mm ² /s (cSt)
Medium temperature	-20 ... +120 °C
Environmental temperature	max. +80 °C
Storage temperature	-20 ... +85 °C
Output signal	frequency (rectangle) / 4 ... 20 mA
Supply voltage U _b	12 ... 24 VDC
Electrical measuring connector	5 pole device connector, M16 x 0.75
Protection type (EN 60529 / IEC 529)	IP 40
Tightening torque	< 0.5 Nm, thread pin (clamping piece) T 3362000
Calibration viscosity	30 mm ² /s (cSt)
Material casing cover	1.4305
Material middle / bottom part	0.7060
Material sealings	FKM
Material gear wheels	1.7131
Suitable measuring cable	MK 01

The volume flow sensor QG 100 with frequency output signal allows detection of the medium flow direction and impulse duplication when used with Hydrotechnik measuring instruments. A possible application is the positioning during cylinder traverse paths.

Pin assignment	QG 100 (frequency)	QG 110 (4 ... 20 mA)
	Pin 1 = signal +	Pin 1 = signal +
	Pin 2 = - U _b / signal - / GND	Pin 2 = signal - / GND
	Pin 3 = + U _b	Pin 3 = + U _b
	Pin 4 = free	Pin 4 = free
	Pin 5 = free	Pin 5 = free

Measuring range	Non-linearity	Geometric gear volume	Allowed working pressure		Impulses per liter	Hydraulic connector	Error limit*
			bar	MPa			
0.05 ... 5.0	± 0.5 %	~ 0.191	630	63	5,250	ISO 228-G¼	± 0.5 %
0.2 ... 30.0**		~ 0.609	160	16	1,640	ISO 228-G ³ / ₈	
0.2 ... 30.0			630	63			
0.7 ... 70.0	± 0.4 %	~ 2.222	420	42	450	ISO 228-G ³ / ₄	± 0.4 %
3 ... 300	± 0.5 %	~ 8.750			100	SAE-Flansch 1¼	± 0.5 %

*: for QG 100 and factory calibrated viscosity
 **: casing material AlCuMgPb F37
 ***: for QG 110 additional ± 0.2 % of final value (error of f/l-converter)
 Factory standard calibration for mineral oil at 30 cSt.
 Other calibration viscosity optional.

Measuring range	Order number / weight			
	QG 100 (frequency)	g	QG 110 (4 ... 20 mA)	g
0.05 ... 5.00	3143-02-35.030	3,000	3185-02-35.030	3,155
0.2 ... 30.0	3843-03-35.030**	1,481	3885-03-35.030**	1,641
0.2 ... 30.0	3143-03-35.030	4,074	3185-03-35.030	4,186
0.7 ... 70.0	3143-04-35.030	9,000	3185-04-35.030	9,100
3 ... 300	3143-05-35.030	32,330	3185-05-35.030	32,490

*: former product name GFM

Dimensions

QG 100

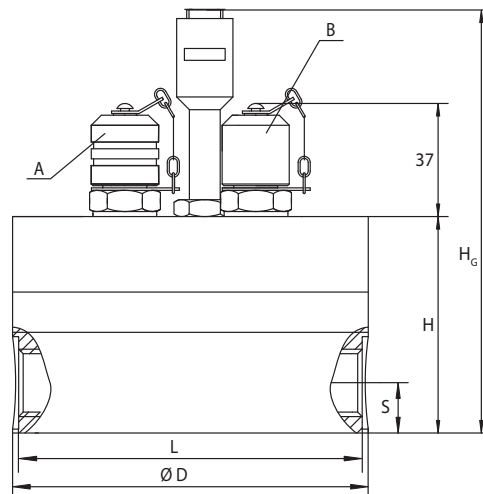

- A MINIMESS® p/T test point, series 1620
- B MINIMESS® test point, series 1620

QG 110

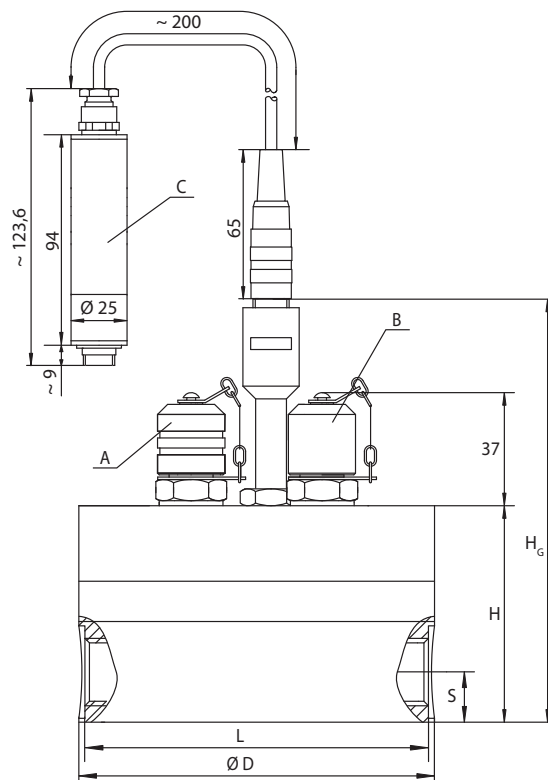

- A MINIMESS® p/T test point, series 1620
- B MINIMESS® test point, series 1620
- C f/l-converter

Measuring range	D	H	H _G	L	S	Type
l/min	mm					see below
0.05 ... 5.00	96	59	125	93	13	A
0.2 ... 30.0	106	67	133	102,5	15	A
0.7 ... 70.0	136	93	153	131	20	A
3 ... 300	210	145	190	210	42	B

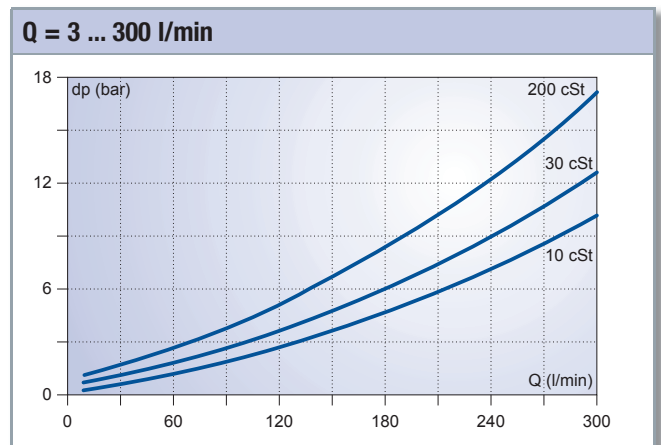
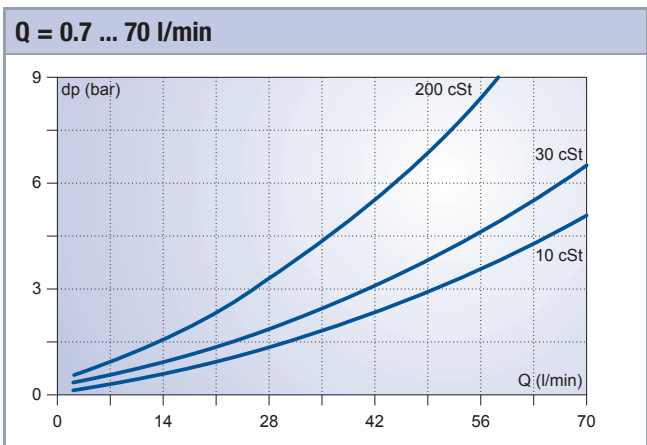
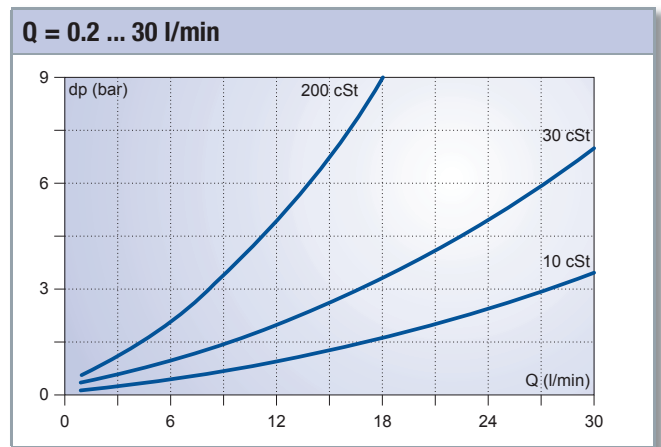
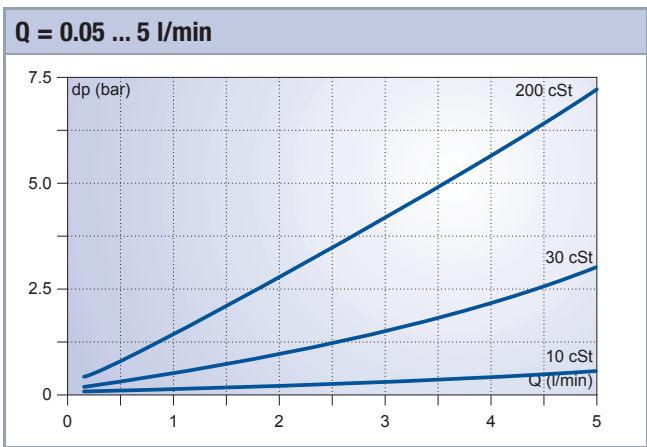
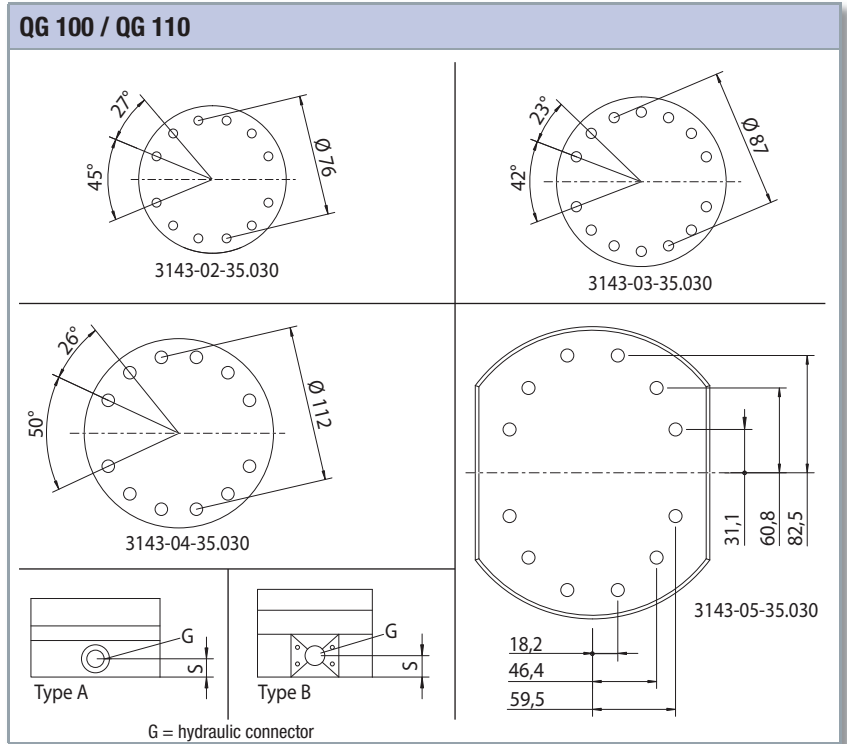

HySense QG 107*

Gear volume flow sensor for high-temperature applications



Qualities	
Measuring principle	displacement
Viscosity range	10 ... 500 mm ² /s (cSt)
Medium temperature	-20 ... +160 °C
Environmental temperature	max. +50 °C (amplifier)
Storage temperature	-20 ... +85 °C
Output signal	frequency (rectangle)
Supply voltage U _b	10 ... 30 VDC
Electrical measuring connector	4 pole device connector, M12 x 1
Protection type (EN 60529 / IEC 529)	IP 64
Tightening torque	8 Nm (± 2 Nm)
Calibration viscosity	30 mm ² /s (cSt)
Material casing cover	1.4305
Material middle / bottom part	0.7060
Material sealings	FKM
Material gear wheels	1.7131
Suitable measuring cable	customer-specific

Pin assignment	Frequency
	Pin 1 = + U _b
	Pin 2 = signal
	Pin 3 = - U _b / GND
	Pin 4 = free

Measuring range	Geometric gear volume	Allowed working pressure		Impulses per liter	Hydraulic connector	Error limit*
		bar	MPa			
l/min	cm ³					of current value
0.2 ... 30.0	~ 0.609	630	63	1,640	ISO 228-G ³ /8	± 0.5 %
0.7 ... 70.0	~ 2.222	420	42	450	ISO 228-G ³ /4	± 0.4 %

Measuring range	Weight	Order number
l/min	g	
0.2 ... 30.0	3,700	3189-03-35.030
0.7 ... 70.0	8,600	3189-04-35.030

*: former product name GFM

*: for factory calibrated viscosity
Factory standard calibration for mineral oil at 30 cSt. Other calibration viscosities optional.

- A MINIMESS® p/T test point, series 1620
- B MINIMESS® test point, series 1620
- C Frequency sensor, high-temperature version

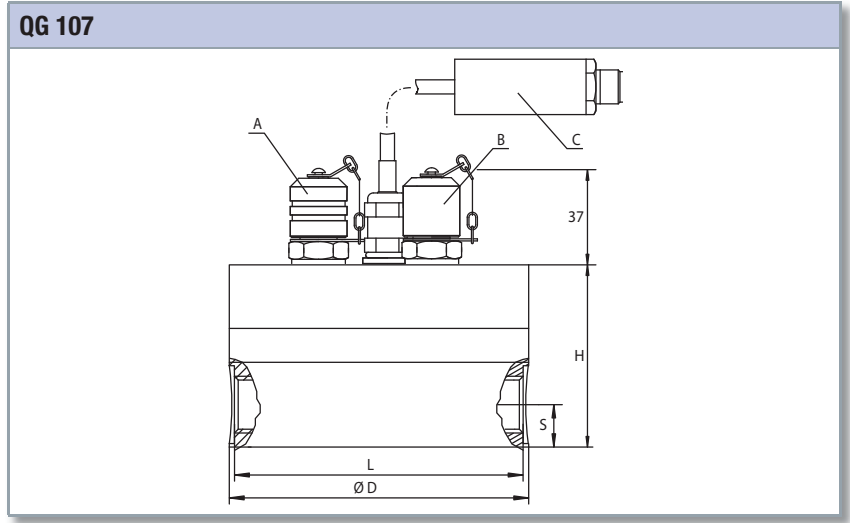

Measuring range	D	H	H _G	L	S	Weight	Type
l/min	mm					g	
0.2 ... 30.0	106	67	133	102.5	15	4,074	A
0.7 ... 70.0	136	93	153	131	20	9,000	A

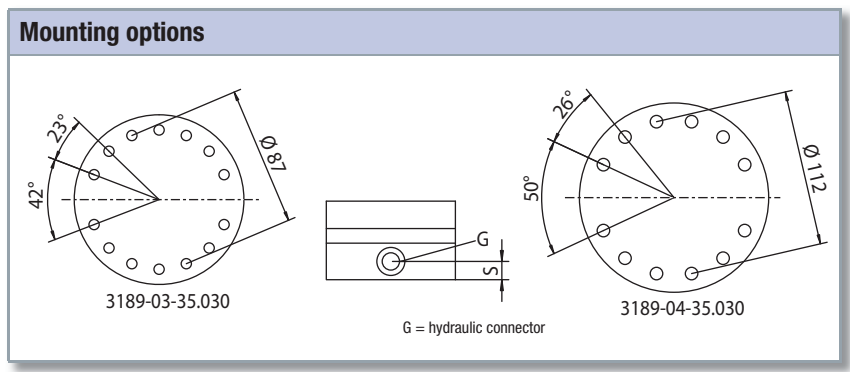

On page 27 you can find the delta-P curves for the volume flow sensors QG 100 / QG 110. These are valid for the sensors QG 107, too.

HySense QO 100

Oval wheel counter for minimal flow rates

The oval wheel counter QO 100 has been developed for the accurate measurement of minimal volume flow rates. They are robust and characterized by their simplicity and user-friendliness. Typical media are water and watery media, but they can also be used for oil, grease and petrol.



Similar illustration

Qualities	
Measuring principle	displacement
Viscosity range	1 ... 150 cSt
Medium temperature	-10 ... +70 °C
Environmental temperature	-10 ... +60 °C
Storage temperature	-10 ... +70 °C
Output signal	REED, NPN
Allowed working pressure	40 bar / 4 MPa
Error limit (calibrated)	< ± 0.5 % of current value
Repeatability	0.1 % of measured value
Electrical measuring connector	depends on output signal
Protection type (EN 60529 / IEC 529)	IP 67
Process connection	inside thread G 1/8" or 1/4"
Calibration viscosity	1 mm ² /s (cSt)
Materials	Aluminium, PPS
EMC test	DIN EN 60947-5-2
Sealings	FKM

Available in several versions:

- different output signals
- different materials
- different calibration viscosities
- on-site display



Q = 0.1 ... 1.0 l/min

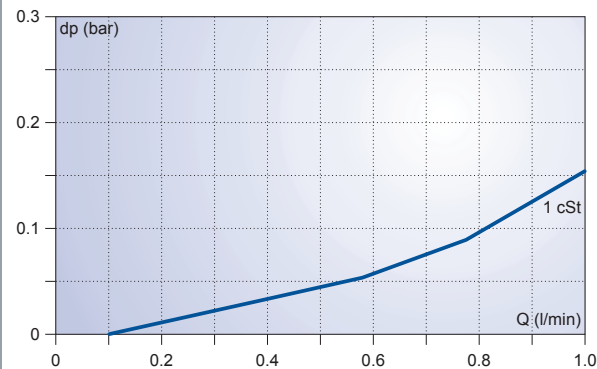

Measuring range	Output signal	Weight	Order number
l/min		g	
0.1 ... 1.0	REED	820	F130-11-11.11
	NPN		F140-11-11.11



HySense QO 200

Oval wheel counter for low volume flow rates



Similar illustration

The oval wheel counters QO 200 are built up modularly to make them suitable for a broad range of applications. They are very robust and user-friendly as a result of their simplicity.

Qualities	
Measuring principle	displacement
Viscosity range	1.5 ... 150 cSt
Medium temperature	-10 ... +80 °C
Environmental temperature	-10 ... +55 °C
Storage temperature	-10 ... +55 °C
Output signal	REED, NPN
Allowed working pressure	40 bar / 4 MPa
Supply voltage U_b	10 ... 30 VDC
Error limit (calibrated)	$< \pm 0.5$ % of current value
Process connection	inside thread G 1/2"
Electrical measuring connector	depends on output signal
Protection type (EN 60529 / IEC 529)	IP 67
Calibration viscosity	1 mm ² /s (cSt)
Materials	Aluminium, PPS
Sealings	NBR

Available in several versions:

- different output signals
- different materials
- different calibration viscosities
- different measuring ranges
- on-site display



Q = 1 ... 10 l/min

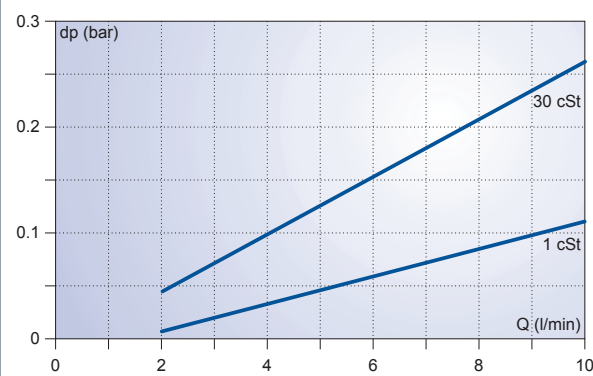

Messbereich	Ausgangssignal	Gewicht	Bestellnummer
l/min		g	
0.2 ... 2.0	REED	2,200	F230-16-13.31
	NPN		F240-16-13.31
0.5 ... 5.0	REED	2,400	F330-16-13.31
	NPN		F340-16-13.31
1.0 ... 10	REED	2,700	F430-16-13.31
	NPN		F440-16-13.31

HySense QO 300

High-precision oval wheel counter for low volume flow rates

The oval wheel counters QO 300 work with very high precision and can be used for many applications. They are suitable for oily media, as long as they do not corrode aluminium; e.g. for hydraulic and grease oils, and petrols in process and laboratory environments.



Similar illustration



Important note:

Please consider when applying the QO 300 that it may not be used for media that corrode Aluminium.

Qualities	
Measuring principle	displacement
Viscosity range	3 ... 2,300 cSt
Medium temperature	-10 ... +80 °C (up to +130 °C on request)
Environmental temperature	-20 ... +65 °C
Storage temperature	-20 ... +65 °C
Output signal	REED, NPN
Allowed working pressure	16 bar / 1.6 MPa
Supply voltage U_b	10 ... 30 VDC
Error limit (of current value)	$\pm 0.3\% \dots \pm 1.0\%$ ($\pm 0.05\%$ on request)
Process connection	inside thread G 3/4"
Electrical measuring connector	depends on output signal
Protection type (EN 60529 / IEC 529)	IP 50
Calibration viscosity	3 mm ² /s (cSt)
Materials	Aluminium
Sealings	compound 19457

Available in several versions:

- different output signals
- different materials
- different calibration viscosities
- on-site display



Q = 1 ... 10 l/min

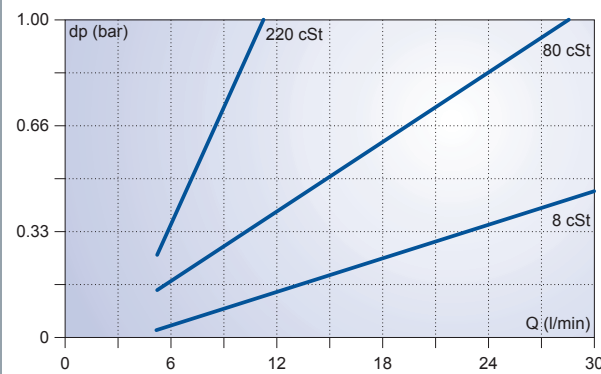

Measuring range	Output signal	Weight	Order number
l/min		g	
1 ... 30	REED	1,400	F770-57-35.64
	NPN		on request