



Rexnord Tollok Locking Assemblies





Why Choose Rexnord Tollok Locking Assemblies?

Why Choose Rexnord?

When it comes to providing highly engineered products that improve productivity and efficiency for industrial applications worldwide, Rexnord is the most reliable in the industry. Our commitment to customer satisfaction and superior value extends to every area of our business.

Delivering Lowest Total Cost of Ownership

The highest quality products are designed to help prevent equipment downtime, increase productivity and deliver dependable operation.

Valuable Expertise

An extensive product offering is accompanied by global sales specialists, customer service and maintenance support teams, available anytime.

Solutions to Enhance Ease of Doing Business

Our commitment to operational excellence means you benefit from getting the right products to the right place at the right time.

Proven Reliability, Dependable Expertise, Broad Range of Options

For more than 35 years, Tollok® products have led the industry in locking assemblies. Our robust product offering features a wide range of options from simple and compact designs to advanced features. Our full line of locking assemblies can be customized to fit our customers ever-changing application needs and are ideal for use in heavy-duty and specially engineered environments.

Deliver Lower Total Cost of Ownership

Tollok designs its product by using state-of-the-art analysis tools to assure the most accurate designs possible. CAD drawings are directly integrated in a production system through CAD-CAM technology. This combined with the latest manufacturing methodology ensures high precision products with a short lead time.

Connecting Technology with Application Solutions

Tollok offers a broad range of internal locking assemblies, shrink discs and rigid couplings to fit to a wide range of applications. Tollok locking assemblies could be an alternative to a shaft/hub connection such as: key, splined, press fit, QD bushing or Taper Lock bushing. Tollok products are dimensionally interchangeable with most industry standard units.

Connecting Technology with the Best Service

Our product line is complemented with industry leading service. Each unit is protected, packed and suitably prepared for shipping. Tollok products are distributed worldwide. Regardless of the location, our customers can rely on our experienced application engineers for technical support.

Industries Served

Aggregates
Agriculture
Air Handling
Cement
Forest Products
Mining

Oil & Gas
Petrochemical
Primary Metals
Power Generation
Water Treatment

Locking assemblies

TLK110
Page 8

Self-centering
Medium-high torque
Available from 1/4 to 4 15/16 inch diameter
Available from 6 to 140 mm diameter
Low surface pressures

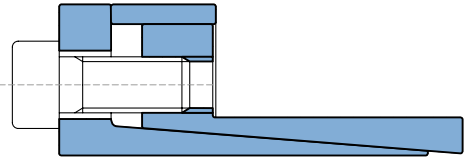

TLK 111
Page 11

Self-centering
Medium torque
Available from 14 mm to 65 mm diameter
Restricted radial encumbrance

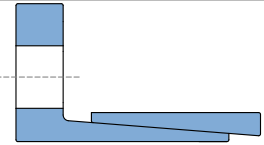

TLK130
Page 13

Self-centering
High torque
Available from 3/4 to 4 inch diameter
Available from 20 to 220 mm diameter
Quick installation
Excellent shaft/hub perpendicularity

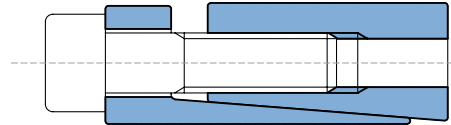

TLK131
Page 13

Self-centering
Medium-high torque
Available from 3/4 to 4 inch diameter
Available from 20 to 220 mm diameter
Low surface pressures
Excellent shaft/hub perpendicularity

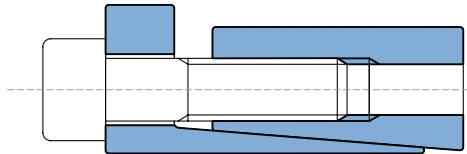

TLK132/139
Page 16 / Page 24

Self-centering
Medium torque
TLK 132: Available from 3/4 to 8 inch diameter
TLK 132: Available from 20 to 220 mm diameter
TLK 139: Available from 18 to 90 mm diameter
Compact space

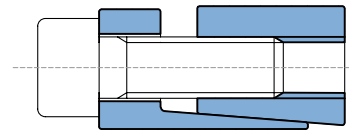

TLK133/134
Page 16 / Page 19

Self-centering
Medium torque
TLK 133: Available from 3/4 to 8 inch diameter
TLK 133: Available from 20 to 220 mm diameter
TLK 134: Available from 14 to 50 mm diameter
Compact space, excellent substitute for TLK200

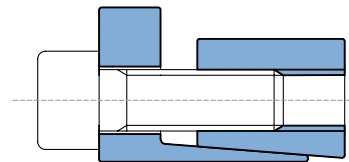

TLK 136
Page 20

Self-centering
High torque
High capacity to absorb bending moment
Available from 100 mm to 600 mm diameter

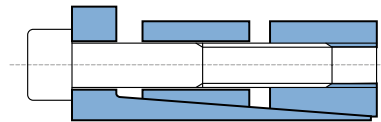

TLK138
Page 22

Self-centering
Medium-low torque
TLK 138: Available from 1/4 to 1 3/8 inch diameter
TLK 138: Available from 6 to 35 mm diameter
Excellent solution for inch hub i.d.

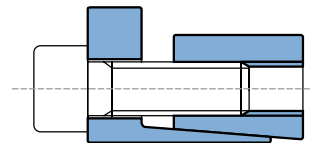

TLK200
Page 25

Not self-centering
Medium torque
Available from 3/4 to 8 inch diameter
Available from 19 to 900 mm diameter
Self-releasing, compact space

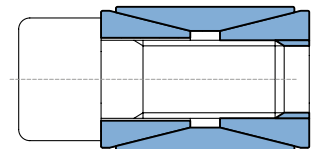

TLK250/250L
Page 28

Low torque
Available from 14 to 70 mm diameter
TLK 250: not self-centering; self-releasing
TLK 250L: self-centering
Quick installation

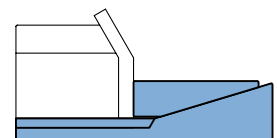

Locking assemblies

TLK300
Page 30

Not self-centering
Low torque
Available from 5 to 540 mm diameter
Compact space, self-releasing

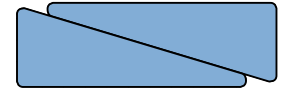

TLK350
Page 32

Self-centering
Medium-high torque
Available from 1/4 to 1 15/16 inch diameter
Available from 6 to 50 mm diameter
Quick installation

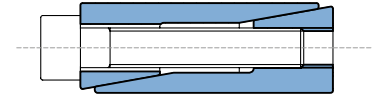

TLK400/401
Page 34

Self-centering
Very high torque
TLK400: Available from 45 to 400 mm diameter
TLK401: Available from 70 to 340 mm diameter
Even pressures distribution

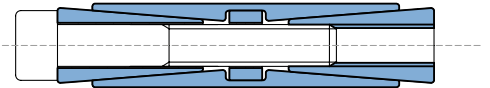

TLK450/451/452
Page 36

Self-centering
Very high torque
TLK450: Available from 1 to 8 inch diameter
TLK450: Available from 25 to 400 mm diameter
TLK451: Available from 70 to 600 mm diameter
TLK452: Available from 1 to 8 inch diameter
Economically advantageous

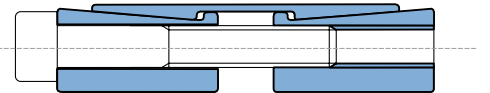

Shrink discs

TLK500
Page 42

Rigid coupling
Medium torque
Available from 14 to 80 mm diameter
Quick installation and dismantling

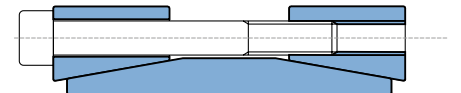

TLK601/602/603
Page 43

Self-centering
High / very high torque
Available from 14 mm to 480 mm diameter
Quick installation

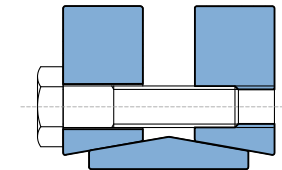

TLK622/623

Page 50

Self-centering
High / very high torque
Available from 12 mm to 620 mm diameter
Quick installation

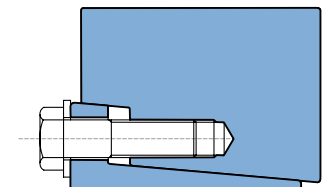

Application examples

Locking assemblies

EA01

Bearing axial fastening and gear locking by means of model TLK 350

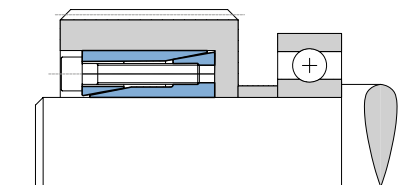

EA02

Chain sprocket locking by means of model TLK 130 with no split outside ring

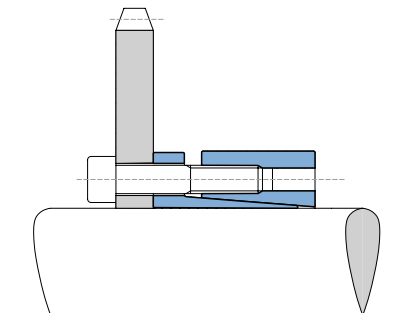

EA03

Thin plate locking by means of model TLK 133 with adapter ring

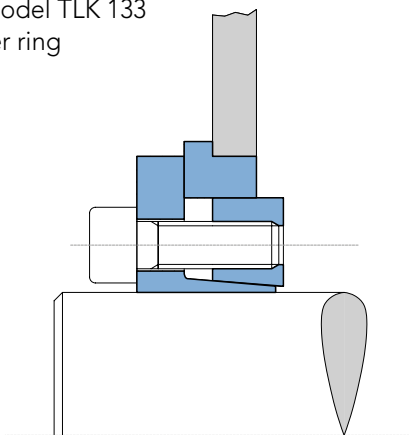

EA04

Break disc locking by means of special model TLK 700

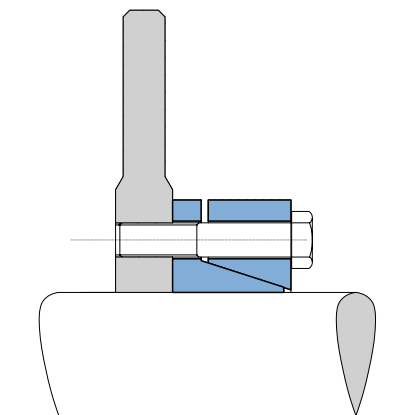

EA05

Hub locking by means of model TLK 200 with a special centering ring

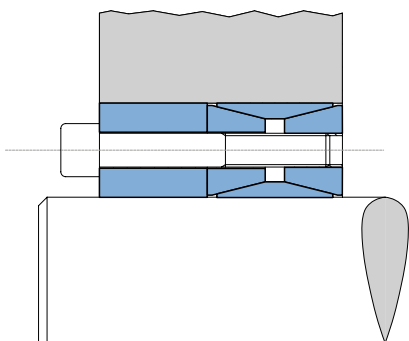

EA06

Large hub locking by means of special version of model TLK 400

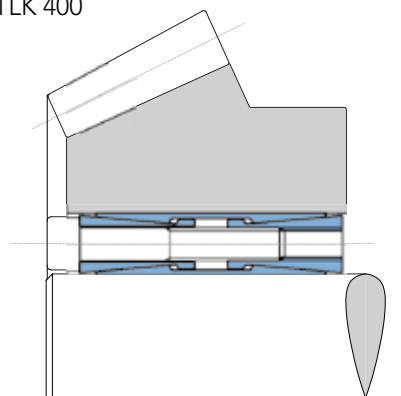

EA07

Cam locking by means of special model TLK 133

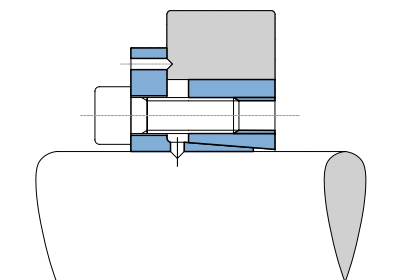

EA08

Use of model TLK 300 without spacer

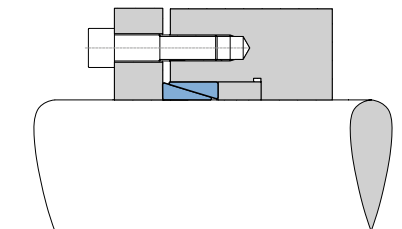

EA09

Use of several locking assemblies in presence of very heavy torque

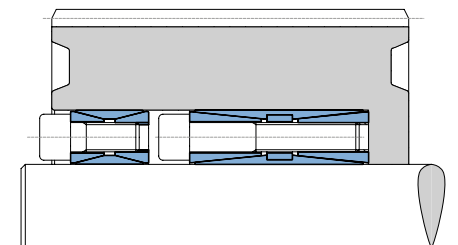

EA10

Use of model TLK 110 in presence of high rpm

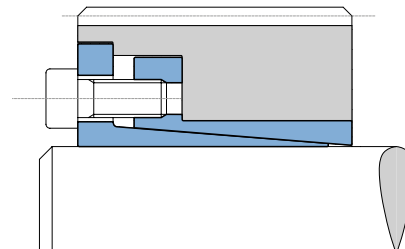

EA11

Special version of model TLK 132 with screws protection ring

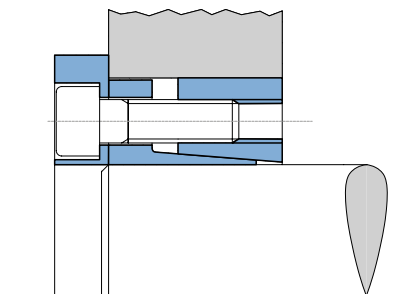

EA12

Special version of model TLK 132 with retaining ring

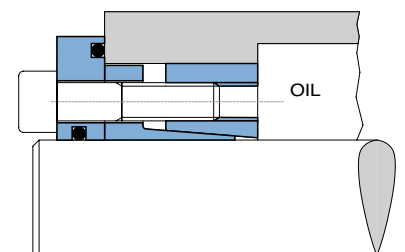

TLK 110

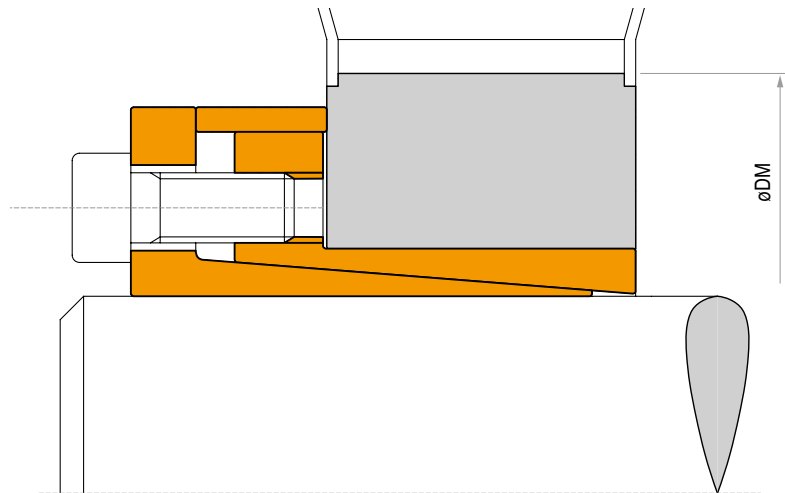

Characteristics

- Medium-high torque
- Restricted hub diameter
- Limited installation time
- Very low surface pressure

Installation

Carefully clean the hub and shaft contact surfaces and apply a thin film of light-weight oil. Slide the locking assembly into the hub bore, insert the shaft and tighten all screws gradually and regularly in crossed sequence to reach the tightening torque M_s as indicated in the rating table.

The values M_t and F_{ax} indicated in the rating table are valid only in case of oil installation. Do not use any oil with **molibdenum bisulphide**, high pressure additives or grease. Above substances notably reduce the coefficient of friction. For additional information on installation refer to page 58.

Dismantling

Loosen the clamping screws. Insert the screws into the dismantling threading and tighten gradually and regularly in crossed sequence until the back cone is released.

If the element is to be reused, relubricate both screws and threadings. For additional information on dismantling refer to page 58.

Tolerances, surface finish

A good surface finish by machine tool is sufficient.
Maximum allowable surface finish:
Rt max 16 μm (Ra 3 μm - Rz 13 μm)

Maximum permissible tolerances:

h8 for shaft
H8 for hub

Axial movement

TLK 110: during screws tightening the hub has no axial movement with respect to the shaft.

DM hub calculation

The pressure P_n in the hub can be compared to the inside pressure on a thick hollow cylinder.

For DM calculation see page 58.

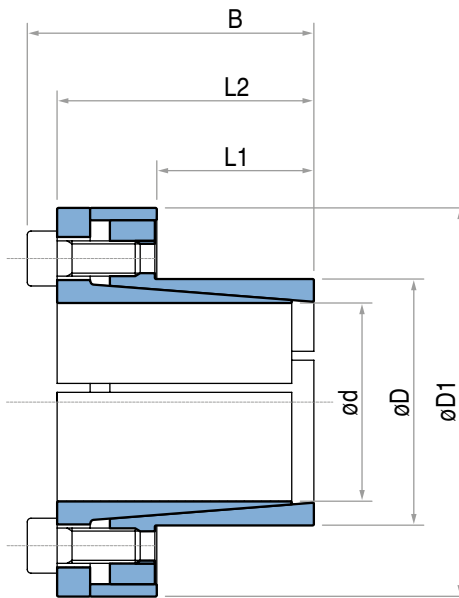

TLK 110 DIMENSIONS

Dimensions							Torque	Axial force	Surface pressures on		Tightening screws		Weight
d x D mm	d inch	D inch	L1 inch	L2 inch	B inch	D1 inch			P _s psi	P _h psi	N° x Type	M _t Lb-ft	
1/4	0,2500	0,551	0,354	0,827	0,945	0,984	13	1266	37922	17200	4 x M3	1	0,1
5/16	0,3125	0,591	0,472	0,984	1,142	1,063	21	1663	29887	15815	3 x M4	4	0,1
3/8	0,3750	0,630	0,551	1,024	1,181	1,102	34	2218	28463	16945	4 x M4	4	0,1
7/16	0,4375	0,709	0,551	1,024	1,181	1,260	40	2218	24397	15062	4 x M4	4	0,2
1/2	0,5000	0,906	0,551	1,024	1,181	1,496	46	2218	21348	11788	4 x M4	4	0,3
5/8	0,6250	0,945	0,630	1,417	1,654	1,732	133	5113	34450	22787	4 x M6	13	0,5
3/4	0,7500	1,063	0,709	1,496	1,732	1,929	159	5113	25518	18004	4 x M6	13	0,6
7/8	0,8750	1,260	0,984	1,772	2,008	2,126	186	5113	15748	10938	4 x M6	13	0,7
15/16	0,9375	1,339	0,984	1,772	2,008	2,205	199	5113	14698	10294	4 x M6	13	0,8
1	1,0000	1,339	0,984	1,772	2,008	2,205	212	5113	13780	10294	4 x M6	13	0,9
1 1/8	1,1250	1,535	0,984	1,772	2,008	2,402	359	7669	18373	13462	6 x M6	13	1
1 3/16	1,1875	1,614	0,984	1,772	2,008	2,441	379	7669	17406	12805	6 x M6	13	1
1 1/4	1,2500	1,693	0,984	1,772	2,008	2,559	399	7669	16536	12210	8 x M6	13	1
1 3/8	1,3750	1,850	1,181	1,969	2,205	2,717	586	10226	16703	12412	8 x M6	13	1
1 7/16	1,4375	1,969	1,181	1,969	2,205	2,835	612	10226	15977	11667	8 x M6	13	1
1 1/2	1,5000	1,969	1,181	1,969	2,205	2,835	639	10226	15311	11667	8 x M6	13	2
1 5/8	1,6250	2,165	1,260	2,047	2,362	3,071	1279	18894	24481	18372	8 x M8	30	2
1 11/16	1,6875	2,323	1,575	2,559	2,874	3,346	1328	18894	18860	13701	8 x M8	30	3
1 3/4	1,7500	2,323	1,575	2,559	2,874	3,346	1377	18894	18186	13701	8 x M8	30	3
1 7/8	1,8750	2,441	1,772	2,756	3,071	3,425	1476	18894	15088	11590	8 x M8	30	3
1 15/16	1,9375	2,559	1,772	2,756	3,071	3,622	1907	23618	18251	13818	10 x M8	30	3
2	2,0000	2,795	1,969	2,953	3,268	3,858	1968	23618	15913	11386	10 x M8	30	4
2 1/8	2,1250	2,795	1,969	2,953	3,268	3,858	2091	23618	14977	11386	10 x M8	30	4
2 3/16	2,1875	3,031	1,969	2,953	3,268	4,094	2152	23618	14549	10498	10 x M8	30	4
2 3/8	2,3750	3,031	1,969	2,953	3,268	4,094	2337	23618	13400	10498	10 x M8	30	4
2 7/16	2,4375	3,307	1,969	2,953	3,268	4,370	2399	23618	13057	9624	10 x M8	30	5
2 1/2	2,5000	3,307	1,969	2,953	3,268	4,370	2460	23618	12730	9624	10 x M8	30	5
2 5/8	2,6250	3,543	2,362	3,583	3,976	4,685	4102	37500	16042	11885	10 x M10	61	7
2 3/4	2,7500	3,543	2,362	3,583	3,976	4,685	4296	37500	15313	11885	10 x M10	61	7
2 7/8	2,8750	3,740	2,362	3,583	3,976	4,961	4492	37500	14647	11259	10 x M10	61	7
2 15/16	2,9375	3,740	2,362	3,583	3,976	4,961	4590	37500	14336	11259	10 x M10	61	7
3	3,0000	3,740	2,362	3,583	3,976	4,961	4687	37500	14037	11259	10 x M10	61	7
3 1/8	3,1250	3,937	2,559	3,780	4,173	5,157	5859	45000	14927	11848	12 x M10	61	8
3 1/4	3,2500	4,173	2,559	3,780	4,173	5,394	6094	45000	14353	11178	12 x M10	61	8
3 3/8	3,3750	4,173	2,559	3,780	4,173	5,394	6328	45000	13821	11178	12 x M10	61	8
3 7/16	3,4375	4,409	2,559	3,780	4,173	5,669	8056	56250	16962	13223	15 x M10	61	9
3 1/2	3,5000	4,409	2,559	3,780	4,173	5,669	8203	56250	16659	13223	15 x M10	61	9
3 5/8	3,6250	4,409	2,559	3,780	4,173	5,669	8496	56250	16085	13223	15 x M10	61	9
3 3/4	3,7500	4,724	2,559	3,780	4,173	5,866	8789	56250	15549	12342	15 x M10	61	10
3 7/8	3,8750	4,921	2,559	3,780	4,173	6,063	10898	67500	18057	14218	18 x M10	61	10
3 15/16	3,9375	4,921	2,559	3,780	4,173	6,063	11074	67500	17770	14218	18 x M10	61	11
4	4,0000	4,921	2,559	3,780	4,173	6,063	11250	67500	17492	14218	18 x M10	61	13
4 1/4	4,2500	5,512	3,543	5,039	5,512	7,087	11602	65520	11541	8899	12 x M12	107	19
4 3/8	4,3750	5,512	3,543	5,039	5,512	7,087	11943	65520	11212	8899	12 x M12	107	20
4 7/16	4,4375	6,102	3,543	5,039	5,512	7,795	12114	65520	11054	8038	12 x M12	107	23
4 1/2	4,5000	6,102	3,543	5,039	5,512	7,795	12285	65520	10900	8038	12 x M12	107	24
4 3/4	4,7500	6,102	3,543	5,039	5,512	7,795	12967	65520	10326	8038	12 x M12	107	24
4 15/16	4,9375	6,496	3,543	5,039	5,512	8,189	17972	87360	13246	10068	16 x M12	107	25

For larger diameter please contact our application engineering department.

TLK 110

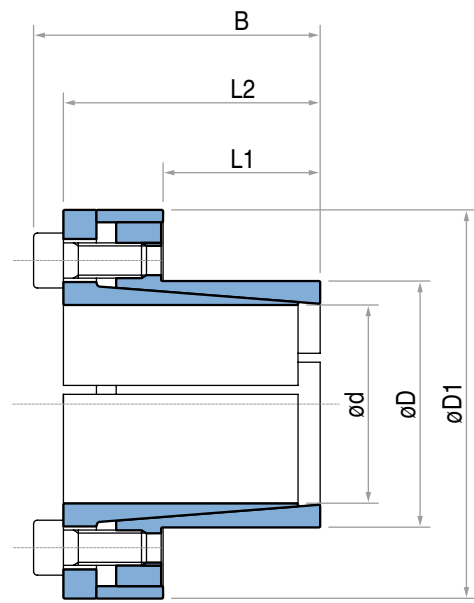

TLK 110 DIMENSIONS

Dimensions							Torque	Axial force	Surface pressures on		Tightening screws		Weight
d x D	d	D	L1	L2	B	D1			Shaft	Hub	DIN912 12.9	Tightening torque	
mm	inch	inch	inch	inch	inch	inch	M _t Lb-ft	F _{ax} Lbf	P _s psi	P _h psi	N° x Type	M _t Lb-ft	Lb
6 x 14	0,236	0,551	0,354	0,827	0,945	0,984	12	1266	40134	17200	4 x M3	1	0,1
7 x 15	0,276	0,591	0,472	0,984	1,142	1,063	18	1663	33889	15815	3 x M4	4	0,1
8 x 15	0,315	0,591	0,472	0,984	1,142	1,063	21	1663	29653	15815	3 x M4	4	0,1
9 x 16	0,354	0,630	0,551	1,024	1,181	1,102	32	2218	30124	16945	4 x M4	4	0,1
10 x 16	0,394	0,630	0,551	1,024	1,181	1,102	36	2218	27111	16945	4 x M4	4	0,1
11 x 18	0,433	0,709	0,551	1,024	1,181	1,260	39	2218	24647	15062	4 x M4	4	0,2
12 x 18	0,472	0,709	0,551	1,024	1,181	1,260	43	2218	22593	15062	4 x M4	4	0,2
13 x 23	0,512	0,906	0,551	1,024	1,181	1,496	46	2218	20855	11788	4 x M4	4	0,2
14 x 23	0,551	0,906	0,551	1,024	1,181	1,496	50	2218	19365	11788	4 x M4	4	0,2
15 x 23	0,591	0,906	0,551	1,181	1,378	1,535	89	3623	29526	19256	4 x M5	7	0,3
15 x 24	0,591	0,945	0,630	1,417	1,654	1,732	125	5113	36459	22787	4 x M6	13	0,5
16 x 24	0,630	0,945	0,630	1,417	1,654	1,732	133	5113	34180	22787	4 x M6	13	0,5
17 x 26	0,669	1,024	0,709	1,496	1,732	1,850	140	5113	28595	18697	4 x M6	13	0,6
18 x 26	0,709	1,024	0,709	1,496	1,732	1,850	148	5113	27007	18697	4 x M6	13	0,5
19 x 27	0,748	1,063	0,709	1,496	1,732	1,929	155	5113	25585	18004	4 x M6	13	0,6
19 x 28	0,748	1,102	0,709	1,496	1,693	1,929	111	3623	18130	12302	4 x M5	7	0,6
20 x 28	0,787	1,102	0,709	1,496	1,732	1,969	162	5113	24306	17361	4 x M6	13	0,6
22 x 32	0,866	1,260	0,984	1,772	2,008	2,126	184	5113	15909	10938	4 x M6	13	0,7
24 x 34	0,945	1,339	0,984	1,772	2,008	2,205	199	5113	14584	10294	4 x M6	13	0,8
25 x 34	0,984	1,339	0,984	1,772	2,008	2,205	207	5113	14000	10294	4 x M6	13	0,8
28 x 39	1,102	1,535	0,984	1,772	2,008	2,402	350	7669	18750	13462	6 x M6	13	1,1
30 x 41	1,181	1,614	0,984	1,772	2,008	2,441	376	7669	17500	12805	6 x M6	13	1,1
32 x 43	1,260	1,693	0,984	1,772	2,008	2,559	531	10226	21875	16279	8 x M6	13	1,0
35 x 47	1,378	1,850	1,181	1,969	2,205	2,717	583	10226	16667	12412	8 x M6	13	1,3
38 x 50	1,496	1,969	1,181	1,969	2,205	2,835	634	10226	15351	11667	8 x M6	13	1,3
40 x 53	1,575	2,087	1,181	1,969	2,205	2,953	664	10226	14584	11007	8 x M6	13	1,5
42 x 55	1,654	2,165	1,260	2,047	2,362	3,071	1291	18894	24059	18372	8 x M8	30	1,7
45 x 59	1,772	2,323	1,575	2,559	2,874	3,346	1394	18894	17964	13701	8 x M8	30	2,6
48 x 62	1,890	2,441	1,772	2,756	3,071	3,425	1482	18894	14970	11590	8 x M8	30	2,6
50 x 65	1,969	2,559	1,772	2,756	3,071	3,622	1918	23618	17964	13818	# x M8	30	3,1
55 x 71	2,165	2,795	1,969	2,953	3,268	3,858	2102	23618	14698	11386	# x M8	30	3,5
60 x 77	2,362	3,031	1,969	2,953	3,268	4,094	2323	23618	13473	10498	# x M8	30	4,0
65 x 84	2,559	3,307	1,969	2,953	3,268	4,370	2508	23618	12437	9624	# x M8	30	4,6
70 x 90	2,756	3,543	2,362	3,583	3,976	4,685	4278	37500	15280	11885	# x M10	61	6,6
75 x 95	2,953	3,740	2,362	3,583	3,976	4,961	4573	37500	14262	11259	# x M10	61	6,6
80 x 100	3,150	3,937	2,559	3,780	4,173	5,157	5900	45000	14810	11848	# x M10	61	7,7
85 x 106	3,346	4,173	2,559	3,780	4,173	5,394	6269	45000	13939	11178	# x M10	61	7,9
90 x 112	3,543	4,409	2,559	3,780	4,173	5,669	8298	56250	16456	13223	# x M10	61	8,6
95 x 120	3,740	4,724	2,559	3,780	4,173	5,866	8740	56250	15590	12342	# x M10	61	9,7
100 x 125	3,937	4,921	2,559	3,780	4,173	6,063	11063	67500	17772	14218	# x M10	61	10,1
110 x 140	4,331	5,512	3,543	5,039	5,512	7,087	11801	65520	11326	8899	# x M12	107	19,2
120 x 155	4,724	6,102	3,543	5,039	5,512	7,795	12907	65520	10382	8038	# x M12	107	23,4
130 x 165	5,118	6,496	3,543	5,039	5,512	8,189	18439	87360	12778	10068	# x M12	107	24,9

For larger diameter please contact our application engineering department. * upon request

TLK 111

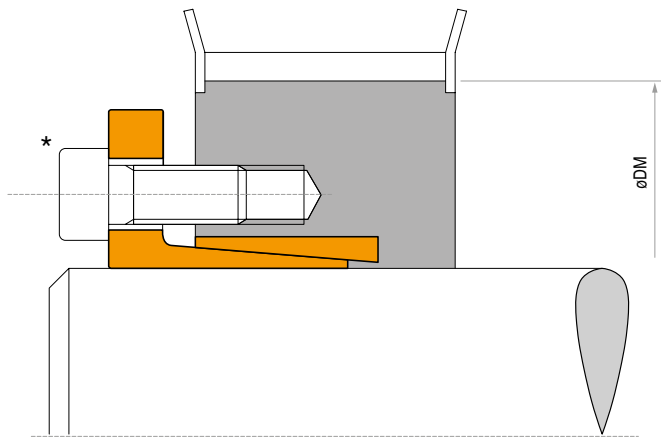

* Upon request.

Characteristics

- Medium torque
- Restricted hub diameter
- Limited installation time
- Very low surface pressure

Installation

Carefully clean the hub and shaft contact surfaces and apply a thin film of light-weight oil. Slide the locking assembly into the hub bore, insert the shaft and the screws (not included in the supply), tighten them gradually and regularly in crossed sequence to reach the tightening torque M_s as indicated in the table.

The values M_t and F_{ax} indicated in the table are valid only in case of screws quality 10.9 or 12.9 and in case of oil installation. Do not use any oil with **molybdenum bisulphide** or high pressure additives and not grease. Above substances notably reduce the friction coefficient.

Dismantling

Loosen the clamping screws. Insert the screws into the dismantling threading and tighten gradually and regularly in crossed sequence until the back cone is released.

If the element is to be reused, relubricate both screws and threadings.

Tolerances, surface finish

A good surface finish by machine tool is sufficient.
Maximum allowable surface finish:
 R_t max 16 μm (R_a 3 μm - R_z 13 μm)

Maximum permissible tolerances:

h8 for shaft

H8 for hub

Axial movement

TLK 111: during screws tightening the hub has a slight axial movement with respect to the shaft.

DM hub calculation

The pressure P_n in the hub can be compared to the inside pressure on a thick hollow cylinder.

For DM calculation see page 54.

Locking assembly - Self-centering

TLK 111

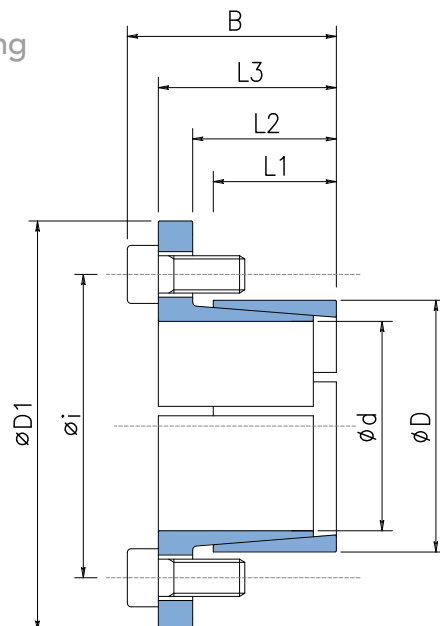

TLK 111 DIMENSIONS

Dimensions								Tightening screws	Screws Class: 10.9					Screws Class: 12.9					Weight
									Tightening torque	Torque	Axial force	Surface pressures on Shaft / Hub		Tightening torque	Torque	Axial force	Surface pressures on Shaft / Hub		
d x D mm	d inch	D inch	L1 inch	L2 inch	L3 inch	D1 inch	i inch	N° x Type	Ms Lb-ft	Mt Lb-ft	Fax Lbf	Ps psi	Ph psi	Mt Lb-ft	Mt Lb-ft	Fax Lbf	Ps psi	Ph psi	Lb
14 x 25	0,5512	0,984	0,630	0,787	1,024	1,654	1,299	4 x M4	3	66	2961	22620	12667	4	81	3558	27186	15224	0,2
15 x 25	0,5906	0,984	0,630	0,787	1,024	1,654	1,299	4 x M4	3	70	2961	21112	12667	4	85	3558	25373	15224	0,2
16 x 25	0,6299	0,984	0,630	0,787	1,024	1,654	1,299	4 x M4	3	77	2961	19793	12667	4	92	3558	23787	15224	0,2
18 x 25	0,7087	0,984	0,630	0,787	1,024	1,654	1,299	4 x M4	3	85	2961	17593	12667	4	103	3558	21144	15224	0,2
19 x 25	0,7480	0,984	0,630	0,787	1,024	1,654	1,299	4 x M4	3	92	2961	16667	12667	4	111	3558	20032	15224	0,2
20 x 30	0,7874	1,181	0,630	0,787	1,024	1,969	1,535	4 x M5	6	159	4862	26003	17335	7	188	5813	31087	20725	0,3
22 x 30	0,8661	1,181	0,630	0,787	1,024	1,969	1,535	4 x M5	6	173	4862	23639	17335	7	207	5813	28261	20725	0,2
24 x 30	0,9449	1,181	0,630	0,787	1,024	1,969	1,535	4 x M5	6	188	4862	21669	17335	7	229	5813	25906	20725	0,2
25 x 36	0,9843	1,417	0,630	0,787	1,024	2,165	1,772	4 x M5	6	199	4862	20802	14446	7	236	5813	24870	17271	0,3
28 x 36	1,1024	1,417	0,630	0,787	1,024	2,165	1,772	4 x M5	6	221	4862	18573	14446	7	266	5813	22205	17271	0,3
30 x 36	1,1811	1,417	0,630	0,787	1,024	2,165	1,772	4 x M5	6	236	4862	17335	14446	7	284	5813	20725	17271	0,3
32 x 42	1,2598	1,654	0,630	0,787	1,102	2,441	2,008	4 x M5	6	254	4862	16252	12382	7	302	5813	19429	14803	0,5
35 x 42	1,3780	1,654	0,630	0,787	1,102	2,441	2,008	4 x M5	6	277	4862	14859	12382	7	332	5813	17764	14803	0,4
36 x 42	1,4173	1,654	0,630	0,787	1,102	2,441	2,008	4 x M5	6	284	4862	14446	12382	7	343	5813	17271	14803	0,4
38 x 44	1,4961	1,732	0,630	0,787	1,102	2,598	2,126	4 x M6	10	424	6845	19267	16640	13	509	8203	23090	19941	0,4
40 x 48	1,5748	1,890	0,630	0,787	1,102	2,756	2,283	4 x M6	10	446	6845	18304	15253	13	535	8203	21935	18279	0,5
42 x 48	1,6535	1,890	0,630	0,787	1,102	2,756	2,283	4 x M6	10	468	6845	17432	15253	13	564	8203	20891	18279	0,4
45 x 55	1,7717	2,165	0,787	0,984	1,378	3,228	2,638	4 x M8	26	929	12604	23966	19608	30	1114	15157	28821	23581	0,9
48 x 55	1,8898	2,165	0,787	0,984	1,378	3,228	2,638	4 x M8	26	988	12604	22468	19608	30	1187	15157	27020	23581	0,7
50 x 62	1,9685	2,441	0,787	0,984	1,378	3,504	2,913	4 x M8	26	1033	12604	21569	17395	30	1239	15157	25939	20918	1,1
55 x 62	2,1654	2,441	0,787	0,984	1,378	3,504	2,913	4 x M8	26	1136	12604	19608	17395	30	1364	15157	23581	20918	0,8
60 x 72	2,3622	2,835	0,787	0,984	1,378	3,898	3,307	4 x M8	26	1239	12604	17974	14979	30	1490	15157	21616	18013	1,2
65 x 72	2,5591	2,835	0,787	0,984	1,378	3,898	3,307	4 x M8	26	1342	12604	16592	14979	30	1615	15157	19953	18013	1,0

For larger diameter please contact our application engineering department.

* upon request

TLK 130

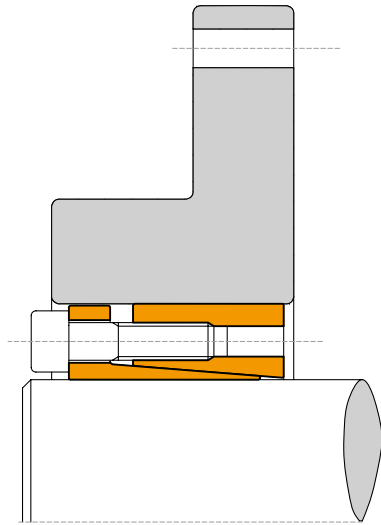

Characteristics

- High torque
- Application economically advantageous
- Quick installation time, low surface pressures
- Excellent shaft-hub perpendicularity

Installation

Carefully clean the hub and shaft contact surfaces and apply a light oil film. Slide the locking assembly into the hub bore, insert the shaft and tighten gradually and regularly incrossed sequence all screws to reach the tightening torque M_s as indicated in the table.

The values M_t and F_{ax} indicated in the table are valid only in case of oil installation. Do not use any oil with **molibdenum bisulphide** or high pressure additives and not grease. Above substances notably reduce the friction coefficient. For additional information on installation refer to page 54.

Dismantling

Loosen the clamping screws. Insert the screws into the dismantling threading and tighten gradually and regularly in crossed sequence until the back cone is released. If the element is to be reused, relubricate both screws and threads. For additional information on dismantling refer to page 58.

TLK 131

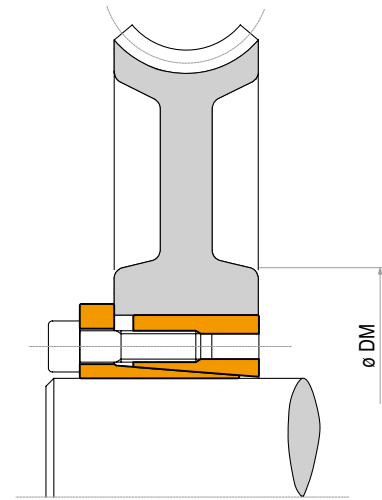

Tolerances, surface finish

A good surface finish by the machine tool is sufficient.
Maximum allowable surface finish:
 R_t max $16 \mu m$ (R_a $3 \mu m$ - R_z $13 \mu m$)

Maximum permissible tolerances:

h8 for shaft

H8 for hub

For exact tolerance values see page 57.

Axial movement

TLK 130: during screws tightening the hub has a slight axial movement with respect to the shaft.

TLK 131: during screws tightening the hub has no axial movement with respect to the shaft.

DM hub calculation

The pressure P_h in the hub can be compared to the inside pressure on a thick hollow cylinder.

For DM calculation see page 54.

TLK 130

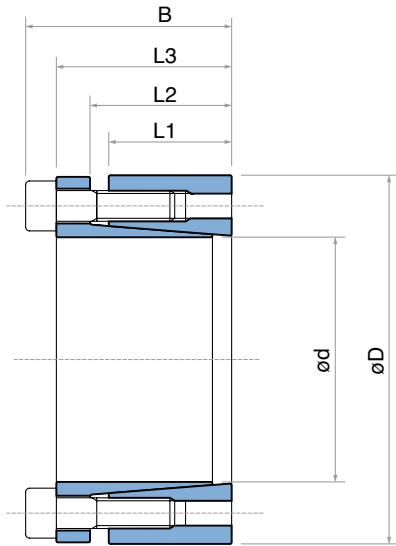

TLK 131

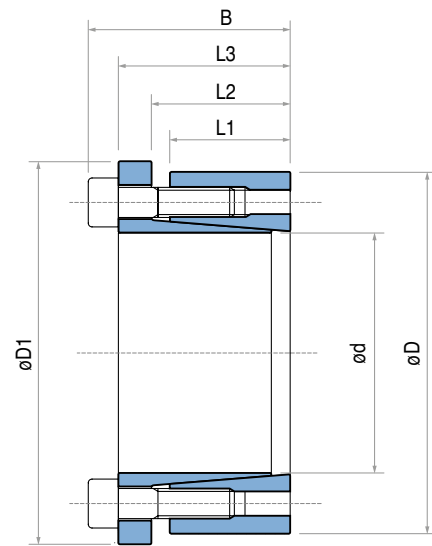

TLK 130 - TLK 131 DIMENSIONS

Dimensions							Only TLK 131	Tightening screws		Torque	Axial force	Surface pressures on		Weight	Torque	Axial force	Surface pressures on		Weight
d	d	D	L1	L2	L3	B		D1	N° x Type			M _s Lb-ft	M _t Lb-ft				F _{ax} Lbf	P _s psi	
7/8	0,8750	1,850	1,024	1,181	1,614	1,850	2,087	6 x M6	13	443	12301	36432	17228	1	273	7669	22714	10741	1
1	1,0000	1,969	1,024	1,181	1,614	1,850	2,205	6 x M6	13	509	12301	31878	16194	1	317	7669	19875	10096	1
1 1/8	1,1250	2,165	1,024	1,181	1,614	1,850	2,402	6 x M6	13	575	12301	28336	14722	1	354	7669	17666	9179	1
1 3/16	1,1875	2,165	1,024	1,181	1,614	1,850	2,402	6 x M6	13	605	12301	26845	14722	1	376	7669	16737	9179	1
1 1/4	1,2500	2,362	1,024	1,181	1,614	1,850	2,598	8 x M6	13	848	16402	34004	17994	1	531	10226	21200	11218	2
1 3/8	1,3750	2,362	1,024	1,181	1,614	1,850	2,598	8 x M6	13	937	16402	30912	17994	1	583	10226	19272	11218	2
1 7/16	1,4375	2,559	1,024	1,181	1,614	1,850	2,795	8 x M6	13	981	16402	29568	16609	2	612	10226	18435	10355	2
1 1/2	1,5000	2,559	1,024	1,181	1,614	1,850	2,795	8 x M6	13	1018	16402	28336	16609	2	634	10226	17666	10355	2
1 5/8	1,6250	2,953	1,181	1,378	1,929	2,244	3,189	6 x M8	30	1534	22729	31414	17288	2	959	14171	19585	10778	3
1 11/16	1,6875	2,953	1,181	1,378	1,929	2,244	3,189	6 x M8	30	1593	22729	30250	17288	2	996	14171	18860	10778	3
1 3/4	1,7500	2,953	1,181	1,378	1,929	2,244	3,189	6 x M8	30	1652	22729	29170	17288	2	1033	14171	18186	10778	3
1 7/8	1,8750	3,150	1,181	1,378	1,929	2,244	3,386	8 x M8	30	2368	30305	36301	21610	2	1475	18894	22632	13473	3
1 15/16	1,9375	3,150	1,181	1,378	1,929	2,244	3,386	8 x M8	30	2441	30305	35130	21610	2	1519	18894	21902	13473	3
2	2,0000	3,150	1,181	1,378	1,929	2,244	3,386	8 x M8	30	2522	30305	34032	21610	2	1571	18894	21217	13473	3
2 1/8	2,1250	3,346	1,181	1,378	1,929	2,244	3,583	8 x M8	30	2677	30305	32030	20339	3	1667	18894	19969	12680	3
2 3/16	2,1875	3,346	1,181	1,378	1,929	2,244	3,583	8 x M8	30	2758	30305	31115	20339	3	1719	18894	19399	12680	3
2 1/4	2,2500	3,543	1,181	1,378	1,929	2,244	3,780	8 x M8	30	2840	30305	30250	19209	3	1770	18894	18860	11976	3
2 3/8	2,3750	3,543	1,181	1,378	1,929	2,244	3,780	8 x M8	30	2995	30305	28658	19209	3	1866	18894	17867	11976	3
2 7/16	2,4375	3,740	1,181	1,378	1,929	2,244	3,976	8 x M8	30	3076	30305	27923	18198	3	1918	18894	17409	11346	4
2 1/2	2,5000	3,740	1,181	1,378	1,929	2,244	3,976	8 x M8	30	3157	30305	27225	18198	3	1962	18894	16974	11346	4
2 9/16	2,5625	3,740	1,181	1,378	1,929	2,244	3,976	8 x M8	30	3231	30305	26561	18198	4	2014	18894	16560	11346	5
2 11/16	2,6875	4,331	1,575	1,772	2,323	2,717	4,606	8 x M10	61	5384	48119	30160	18716	5	3356	30000	18803	11669	6
2 3/4	2,7500	4,331	1,575	1,772	2,323	2,717	4,606	8 x M10	61	5510	48119	29474	18716	5	3437	30000	18376	11669	6
2 7/8	2,8750	4,528	1,575	1,772	2,323	2,717	4,803	8 x M10	61	5760	48119	28193	17902	6	3592	30000	17577	11161	7
2 15/16	2,9375	4,528	1,575	1,772	2,323	2,717	4,803	8 x M10	61	5886	48119	27593	17902	6	3666	30000	17203	11161	7
3	3,0000	4,528	1,575	1,772	2,323	2,717	4,803	8 x M10	61	6011	48119	27018	17902	6	3747	30000	16845	11161	7
3 1/4	3,2500	4,921	1,575	1,772	2,323	2,717	5,197	10 x M10	61	8143	60149	31175	20588	6	5074	37500	19436	12836	7
3 3/8	3,3750	4,921	1,575	1,772	2,323	2,717	5,197	10 x M10	61	8452	60149	30020	20588	6	5266	37500	18716	12836	7
3 7/16	3,4375	5,118	1,575	1,772	2,323	2,717	5,394	10 x M10	61	8615	60149	29474	19796	6	5369	37500	18376	12342	8
3 1/2	3,5000	5,118	1,575	1,772	2,323	2,717	5,394	10 x M10	61	8770	60149	28948	19796	7	5465	37500	18048	12342	8
3 3/4	3,7500	5,315	1,575	1,772	2,323	2,717	5,591	10 x M10	61	9397	60149	27018	19063	8	5856	37500	16845	11885	9
3 15/16	3,9375	5,709	1,811	2,047	2,677	3,150	6,024	8 x M12	107	11491	70061	26062	17976	9	7162	43680	16249	11207	10
4	4,0000	5,709	1,811	2,047	2,677	3,150	6,024	8 x M12	107	11676	70061	25655	17976	9	7280	43680	15995	11207	11

NOTE: it is possible to reduce the screws tightening torque down to 60% of the values indicated in the above table; as a result the M_t, F_{ax}, P_s, P_h are reduced proportionally.

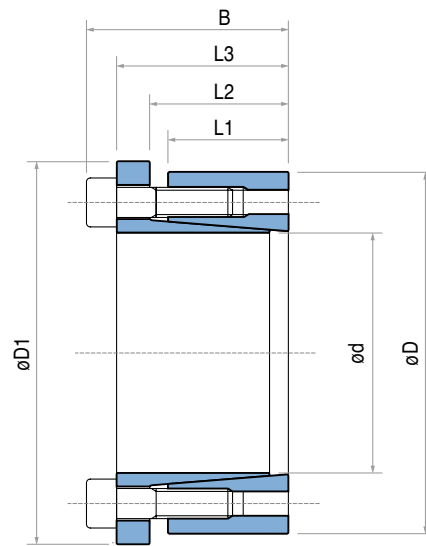
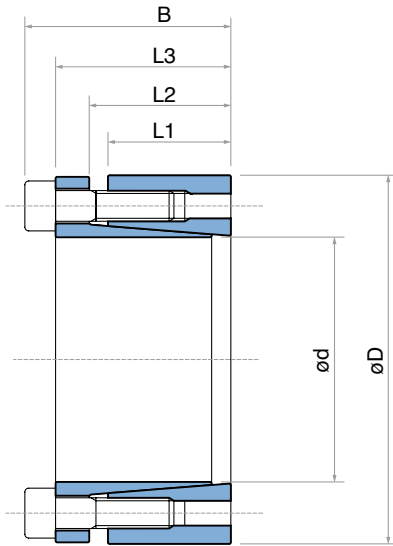

TLK 130 - TLK 131 DIMENSIONS

Dimensions							Only TLK 131	Tightening screws		Torque	Axial force	Surface pressures on		Weight	Torque	Axial force	Surface pressures on		Weight
								DIN912 12.9	Tightening torque			Shaft	Hub				Shaft	Hub	
d x D mm	d inch	D inch	L1 inch	L2 inch	L3 inch	B inch	D1 inch	N° x Type	M _s Lb-ft	M _t Lb-ft	F _{ax} Lbf	P _s psi	P _h psi	Lb	M _t Lb-ft	F _{ax} Lbf	P _s psi	P _h psi	Lb
18 x 47	0,709	1,850	1,024	1,181	1,614	1,850	2,087	6 x M6	13	361	12301	44984	17228	1	221	7669	28045	10741	1
19 x 47	0,748	1,850	1,024	1,181	1,614	1,850	2,087	6 x M6	13	376	12301	42616	17228	1	236	7669	26569	10741	1
20 x 47	0,787	1,850	1,024	1,181	1,614	1,850	2,087	6 x M6	13	398	12301	40486	17228	1	251	7669	25241	10741	1
22 x 47	0,866	1,850	1,024	1,181	1,614	1,850	2,087	6 x M6	13	443	12301	36805	17228	1	273	7669	22946	10741	1
24 x 50	0,945	1,969	1,024	1,181	1,614	1,850	2,205	6 x M6	13	479	12301	33738	16194	1	295	7669	21034	10096	1
25 x 50	0,984	1,969	1,024	1,181	1,614	1,850	2,205	6 x M6	13	502	12301	32388	16194	1	310	7669	20193	10096	1
28 x 55	1,102	2,165	1,024	1,181	1,614	1,850	2,402	6 x M6	13	561	12301	28918	14722	1	347	7669	18029	9179	1
30 x 55	1,181	2,165	1,024	1,181	1,614	1,850	2,402	6 x M6	13	605	12301	26990	14722	1	376	7669	16827	9179	1
32 x 60	1,260	2,362	1,024	1,181	1,614	1,850	2,598	8 x M6	13	856	16402	33738	17994	1	531	10226	21034	11218	2
35 x 60	1,378	2,362	1,024	1,181	1,614	1,850	2,598	8 x M6	13	937	16402	30846	17994	1	583	10226	19231	11218	1
38 x 65	1,496	2,559	1,024	1,181	1,614	1,850	2,795	8 x M6	13	1018	16402	28411	16609	1	634	10226	17713	10355	2
40 x 65	1,575	2,559	1,024	1,181	1,614	1,850	2,795	8 x M6	13	1069	16402	26990	16609	1	664	10226	16827	10355	1
42 x 75	1,654	2,953	1,181	1,378	1,929	2,244	3,189	6 x M8	30	1564	22729	30872	17288	2	974	14171	19247	10778	3
45 x 75	1,772	2,953	1,181	1,378	1,929	2,244	3,189	6 x M8	30	1674	22729	28814	17288	2	1040	14171	17964	10778	2
48 x 80	1,890	3,150	1,181	1,378	1,929	2,244	3,386	8 x M8	30	2382	30305	36017	21610	2	1482	18894	22455	13473	3
50 x 80	1,969	3,150	1,181	1,378	1,929	2,244	3,386	8 x M8	30	2486	30305	34576	21610	2	1549	18894	21557	13473	2
55 x 85	2,165	3,346	1,181	1,378	1,929	2,244	3,583	8 x M8	30	2729	30305	31433	20339	2	1704	18894	19597	12680	3
60 x 90	2,362	3,543	1,181	1,378	1,929	2,244	3,780	8 x M8	30	2980	30305	28814	19209	3	1859	18894	17964	11976	3
65 x 95	2,559	3,740	1,181	1,378	1,929	2,244	3,976	8 x M8	30	3231	30305	26597	18198	3	2014	18894	16582	11346	3
70 x 110	2,756	4,331	1,575	1,772	2,323	2,717	4,606	8 x M10	61	5524	48119	29411	18716	5	3444	30000	18336	11669	6
75 x 115	2,953	4,528	1,575	1,772	2,323	2,717	4,803	8 x M10	61	5915	48119	27450	17902	6	3688	30000	17114	11161	6
80 x 120	3,150	4,724	1,575	1,772	2,323	2,717	5,000	8 x M10	61	6314	48119	25735	17156	6	3931	30000	16044	10696	6
85 x 125	3,346	4,921	1,575	1,772	2,323	2,717	5,197	10 x M10	61	8386	60149	30276	20588	6	5222	37500	18876	12836	6
90 x 130	3,543	5,118	1,575	1,772	2,323	2,717	5,394	10 x M10	61	8880	60149	28594	19796	6	5532	37500	17827	12342	7
95 x 135	3,740	5,315	1,575	1,772	2,323	2,717	5,591	10 x M10	61	9367	60149	27089	19063	6	5841	37500	16889	11885	7
100 x 145	3,937	5,709	1,811	2,047	2,677	3,150	6,024	8 x M12	107	11491	70061	26066	17976	9	7162	43680	16251	11207	10
110 x 155	4,331	6,102	1,811	2,047	2,677	3,150	6,417	8 x M12	107	12642	70061	23696	16816	9	7877	43680	14773	10484	11
120 x 165	4,724	6,496	1,811	2,047	2,677	3,150	6,811	10 x M12	107	17237	87576	27152	19747	11	10746	54600	16928	12311	12
130 x 180	5,118	7,087	1,811	2,047	2,677	3,150	7,402	12 x M12	107	22407	105091	30076	21721	11	13969	65520	18751	13542	13
140 x 190	5,512	7,480	1,969	2,244	2,992	3,543	7,835	10 x M14	170	27592	120163	29378	21647	14	17185	74916	18316	13496	17
150 x 200	5,906	7,874	1,969	2,244	2,992	3,543	8,228	12 x M14	170	35477	144195	32903	24677	15	22127	89899	20514	15385	17
160 x 210	6,299	8,268	1,969	2,244	2,992	3,543	8,622	12 x M14	170	37837	144195	30847	23502	15	23602	89899	19232	14653	18
170 x 225	6,693	8,858	1,969	2,244	2,992	3,543	9,213	14 x M14	170	46909	168228	33871	25591	19	29244	104882	21117	15955	22
180 x 235	7,087	9,252	1,969	2,244	2,992	3,543	9,606	14 x M14	170	49675	168228	31989	24502	20	30978	104882	19944	15276	22
190 x 250	7,480	9,843	1,969	2,244	2,992	3,543	10,197	15 x M14	170	56165	180244	32470	24677	23	35034	112374	20244	15385	25
200 x 260	7,874	10,236	1,969	2,244	2,992	3,543	10,591	16 x M14	170	63062	192260	32903	25310	23	39312	119865	20514	15780	25
210 x 270	8,268	10,630	1,969	2,244	2,992	3,543	10,984	16 x M14	170	66233	192260	31336	24373	24	41303	119865	19537	15195	26
220 x 285	8,661	11,220	2,520	2,835	3,701	4,331	11,575	12 x M16	262	72318	200407	24359	18803	36	45102	124944	15187	11723	39
240 x 305	9,449	12,008	2,520	2,835	3,701	4,331	12,362	15 x M16	262	98612	250508	27911	21963	40	61476	156181	17401	13693	42

For larger diameter please contact our application engineering department.

NOTE: it is possible to reduce the screws tightening torque down to 60% of the values indicated in the above table; as a result the M_t, F_{ax}, P_s, P_h are reduced proportionally.

TLK 132

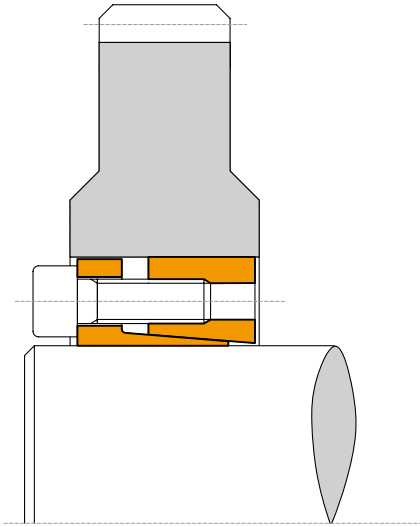

Characteristics

- Medium-high torque
- Application economically advantageous
- Limited installation time
- Interchangeable with TLK 200

Installation

Carefully clean the hub and shaft contact surfaces and apply a light oil film. Slide the locking assembly into the hub bore, insert the shaft and tighten gradually and regularly in crossed sequence all screws to reach the tightening torque M_s as indicated in the table.

The values M_t and F_{ax} indicated in the table are valid only in case of oil installation. Do not use any oil **with molybdenum bisulphide** or high pressure additives and not grease. Above substances notably reduce the friction coefficient. For additional information on installation refer to page 58.

Dismantling

Loosen the clamping screws. Insert the screws into the dismantling threading and tighten gradually and regularly in crossed sequence until the back cone is released. If the element is to be reused, relubricate both screws and threads. For additional information on dismantling refer to page 58.

TLK 133

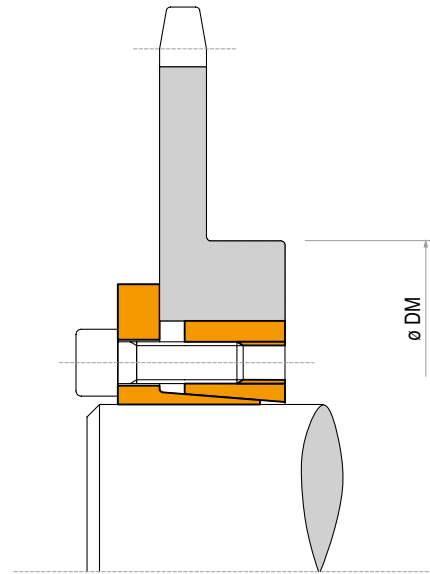

Tolerances, surface finish

A good surface finish by the machine tool is sufficient.
Maximum allowable surface finish:
Rt max 16 μm (Ra 3 μm - Rz 13 μm)

Maximum permissible tolerances:
h8 for shaft
H8 for hub

For exact tolerance values see page 57.

Axial movement

TLK 132: during screws tightening the hub has a slight axial movement with respect to the shaft.

TLK 133: during screws tightening the hub has no axial movement with respect to the shaft.

DM hub calculation

The pressure P_n in the hub can be compared to the inside pressure on a thick hollow cylinder.

For DM calculation see page 54.

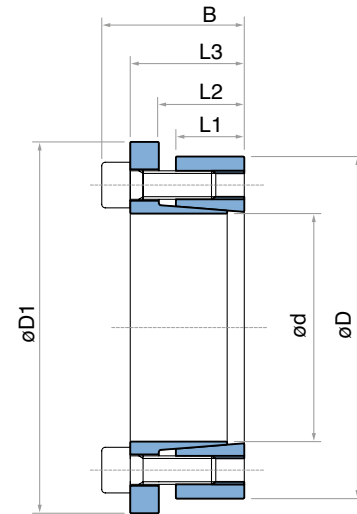
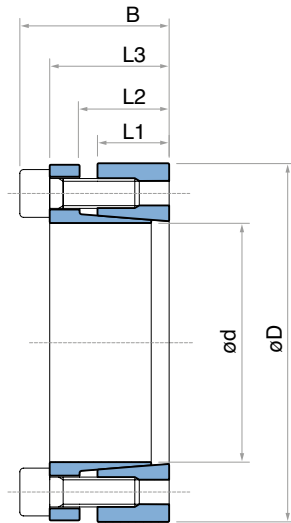

TLK 132 - TLK 133 DIMENSIONS

Dimensions							Only TLK 133	Tightening screws		Torque	Axial force	Surface pressures on		Weight	Torque	Axial force	Surface pressures on		Weight
								DIN912 12.9	Tightening torque			Shaft	Hub				Shaft	Hub	
d inch	d inch	D inch	L1 inch	L2 inch	L3 inch	B inch	D1 inch	N° x Type	M _t Lb-ft TLK 132 TLK 133	M _t Lb-ft	F _{ax} Lbf	P _s psi	P _h psi	Lb	M _t Lb-ft	F _{ax} Lbf	P _s psi	P _h psi	Lb
3/4	0,7500	1,850	0,669	0,866	1,102	1,339	2,087	5 x M6	10 13	258	8442	44613	18082	1	199	6391	33774	13689	1
7/8	0,8750	1,850	0,669	0,866	1,102	1,339	2,087	6 x M6	10 13	369	10131	45887	21699	1	273	7669	34739	16427	1
1	1,0000	1,969	0,669	0,866	1,102	1,339	2,205	6 x M6	10 13	420	10131	40151	20397	1	317	7669	30397	15441	1
1 1/8	1,1250	2,165	0,669	0,866	1,102	1,339	2,402	6 x M6	10 13	472	10131	35690	18543	1	354	7669	27019	14038	1
1 3/16	1,1875	2,165	0,669	0,866	1,102	1,339	2,402	6 x M6	10 13	494	10131	33812	18543	1	376	7669	25597	14038	1
1 1/4	1,2500	2,362	0,669	0,866	1,102	1,339	2,638	8 x M6	10 13	701	13507	42828	22663	1	531	10226	32423	17157	1
1 3/8	1,3750	2,362	0,669	0,866	1,102	1,339	2,638	8 x M6	10 13	767	13507	38935	22663	1	583	10226	29476	17157	2
1 7/16	1,4375	2,559	0,669	0,866	1,102	1,339	2,835	8 x M6	10 13	804	13507	37242	20920	1	612	10226	28194	15837	2
1 1/2	1,5000	2,559	0,669	0,866	1,102	1,339	2,835	8 x M6	10 13	841	13507	35690	20920	1	634	10226	27019	15837	2
1 5/8	1,6250	2,953	0,787	0,984	1,299	1,614	3,228	8 x M8	26 30	1748	25870	53634	29516	2	1276	18894	39170	21557	2
1 11/16	1,6875	2,953	0,787	0,984	1,299	1,614	3,228	8 x M8	26 30	1814	25870	51647	29516	2	1328	18894	37720	21557	2
1 3/4	1,7500	2,953	0,787	0,984	1,299	1,614	3,228	8 x M8	26 30	1881	25870	49803	29516	2	1372	18894	36372	21557	2
1 7/8	1,8750	3,150	0,787	0,984	1,299	1,614	3,425	8 x M8	26 30	2021	25870	46482	27672	2	1475	18894	33948	20209	2
1 15/16	1,9375	3,150	0,787	0,984	1,299	1,614	3,425	8 x M8	26 30	2087	25870	44983	27672	2	1519	18894	32853	20209	2
2	2,0000	3,150	0,787	0,984	1,299	1,614	3,425	8 x M8	26 30	2154	25870	43577	27672	2	1571	18894	31826	20209	3
2 1/8	2,1250	3,346	0,787	0,984	1,299	1,614	3,622	8 x M8	26 30	2286	25870	41014	26044	2	1667	18894	29954	19021	3
2 3/16	2,1875	3,346	0,787	0,984	1,299	1,614	3,622	8 x M8	26 30	2353	25870	39842	26044	2	1719	18894	29098	19021	3
2 1/4	2,2500	3,543	0,787	0,984	1,299	1,614	3,819	8 x M8	26 30	2419	25870	38735	24597	2	1770	18894	28290	17964	3
2 3/8	2,3750	3,543	0,787	0,984	1,299	1,614	3,819	8 x M8	26 30	2559	25870	36697	24597	2	1866	18894	26801	17964	3
2 7/16	2,4375	3,740	0,787	0,984	1,299	1,614	4,016	9 x M8	26 30	2950	29104	40225	26215	2	2154	21256	29378	19146	3
2 1/2	2,5000	3,740	0,787	0,984	1,299	1,614	4,016	9 x M8	26 30	3031	29104	39220	26215	2	2213	21256	28643	19146	3
2 9/16	2,5625	3,740	0,787	0,984	1,299	1,614	4,016	9 x M8	26 30	3105	29104	38263	26215	2	2264	21256	27945	19146	3
2 11/16	2,6875	4,331	0,945	1,181	1,575	1,969	4,606	8x M10	52 61	4543	40583	42393	26308	4	3356	30000	31339	19448	6
2 3/4	2,7500	4,331	0,945	1,181	1,575	1,969	4,606	8 x M10	52 61	4647	40583	41430	26308	4	3437	30000	30626	19448	6
2 7/8	2,8750	4,528	0,945	1,181	1,575	1,969	4,803	8 x M10	52 61	4861	40583	39628	25164	4	3592	30000	29295	18602	6
2 15/16	2,9375	4,528	0,945	1,181	1,575	1,969	4,803	8 x M10	52 61	4964	40583	38785	25164	4	3666	30000	28672	18602	6
3	3,0000	4,724	0,945	1,181	1,575	1,969	5,000	8 x M10	52 61	5067	40583	37977	24115	4	3747	30000	28074	18272	6
3 1/4	3,2500	4,921	0,945	1,181	1,575	1,969	5,197	10 x M10	52 61	6867	50728	43820	28939	4	5074	37500	32393	21393	6
3 3/8	3,3750	4,921	0,945	1,181	1,575	1,969	5,197	10 x M10	52 61	7132	50728	42197	28939	4	5266	37500	31194	21393	6
3 7/16	3,4375	5,118	0,945	1,181	1,575	1,969	5,394	10 x M10	52 61	7265	50728	41430	27826	5	5369	37500	30626	20570	6
3 1/2	3,5000	5,118	0,945	1,181	1,575	1,969	5,394	10 x M10	52 61	7398	50728	40690	27826	5	5465	37500	30079	20570	7
3 3/4	3,7500	5,315	0,945	1,181	1,575	1,969	5,591	10 x M10	52 61	7921	50728	37977	26795	5	5856	37500	28074	19808	7
3 15/16	3,9375	5,709	1,024	1,260	1,732	2,205	5,984	8 x M12	92 107	9905	60397	39750	27417	6	7162	43680	28748	19828	9
4	4,0000	5,709	1,024	1,260	1,732	2,205	5,984	8 x M12	92 107	10060	60397	39129	27417	6	7280	43680	28298	19828	9
4 7/16	4,4375	6,102	1,024	1,260	1,732	2,205	6,378	8 x M12	92 107	11167	60397	35271	25648	7	8069	43680	25508	18549	9
4 3/4	4,7500	6,496	1,024	1,260	1,732	2,205	6,772	9 x M12	92 107	13446	67947	37070	27106	7	9721	49140	26809	19603	10
4 15/16	4,9375	7,087	1,339	1,575	2,126	2,598	7,362	12 x M12	92 107	18638	90596	36361	25334	11	13475	65520	26297	18322	15
5 7/16	5,4375	7,480	1,339	1,575	2,126	2,677	7,756	9 x M14	140 170	20239	89338	32559	23668	11	15275	67424	24573	17862	16
5 15/16	5,9375	7,874	1,339	1,575	2,126	2,677	8,150	10 x M14	140 170	24553	99265	33130	24982	12	18528	74916	25004	18854	17
6 7/16	6,4375	8,858	1,732	1,969	2,520	3,071	9,134	12 x M14	140 170	31944	119118	28335	20592	18	24111	89899	21385	15541	25
6 15/16	6,9375	9,252	1,732	1,969	2,520	3,071	9,528	12 x M14	140 170	34429	119118	26293	19715	18	25984	89899	19843	14879	26
7 7/16	7,4375	9,843	1,732	1,969	2,520	3,071	10,118	15 x M14	140 170	46142	148897	30656	23166	21	34820	112374	23137	17483	30
7 15/16	7,9375	10,236	1,732	1,969	2,520	3,071	10,512	15 x M14	140 170	49240	148897	28725	22275	22	37158	112374	21679	16811	31
8	8,0000	10,236	1,732	1,969	2,520	3,071	10,512	15 x M14	140 170	49631	148897	28501	22275	22	37453	112374	21510	16811	31

For larger diameter please contact our application engineering department. NOTE: it is possible to reduce the screws tightening torque down to 60% of the values indicated in the above table; as a result the M_t, F_{ax}, P_s, P_n are reduced proportionally.

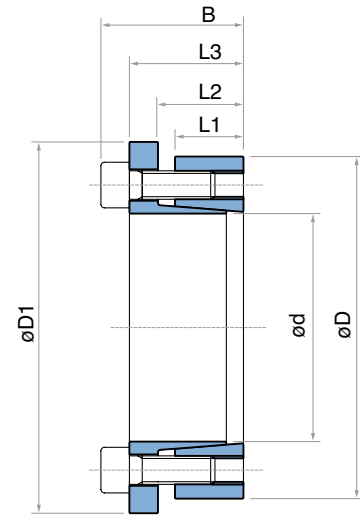
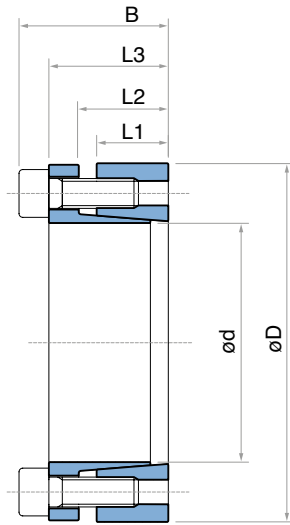

TLK 132 - TLK 133 DIMENSIONS

Dimensions							Only TLK 133	Tightening screws		Torque	Axial force	Surface pressures on		Weight	Torque	Axial force	Surface pressures on		Weight	
								DIN912 12.9	Tightening torque			Shaft	Hub				Shaft	Hub		
d x D mm	d inch	D inch	L1 inch	L2 inch	L3 inch	B inch	D1 inch	N° x Type	M _t Lb-ft TLK 132	M _t Lb-ft TLK 133	M _t Lb-ft	F _{ax} Lbf	P _s psi	P _h psi	Lb	M _t Lb-ft	F _{ax} Lbf	P _s psi	P _h psi	Lb
18 x 47	0,709	1,850	0,669	0,866	1,102	1,339	2,087	5 x M6	10	13	243	8442	47215	18082	1	184	6391	35744	13689	1
19 x 47	0,748	1,850	0,669	0,866	1,102	1,339	2,087	5 x M6	10	13	258	8442	44730	18082	1	199	6391	33863	13689	1
20 x 47	0,787	1,850	0,669	0,866	1,102	1,339	2,087	6 x M6	10	13	332	10131	50992	21699	1	251	7669	38604	16427	1
22 x 47	0,866	1,850	0,669	0,866	1,102	1,339	2,087	6 x M6	10	13	361	10131	46357	21699	1	273	7669	35094	16427	1
24 x 50	0,945	1,969	0,669	0,866	1,102	1,339	2,205	6 x M6	10	13	398	10131	42493	20397	1	295	7669	32170	15441	1
25 x 50	0,984	1,969	0,669	0,866	1,102	1,339	2,205	6 x M6	10	13	413	10131	40794	20397	1	310	7669	30883	15441	1
28 x 55	1,102	2,165	0,669	0,866	1,102	1,339	2,402	6 x M6	10	13	465	10131	36423	18543	1	347	7669	27574	14038	1
30 x 55	1,181	2,165	0,669	0,866	1,102	1,339	2,402	6 x M6	10	13	494	10131	33995	18543	1	376	7669	25736	14038	1
32 x 60	1,260	2,362	0,669	0,866	1,102	1,339	2,638	8 x M6	10	13	708	13507	42493	22663	1	531	10226	32170	17157	1
35 x 60	1,378	2,362	0,669	0,866	1,102	1,339	2,638	8 x M6	10	13	774	13507	38851	22663	1	583	10226	29412	17157	1
38 x 65	1,496	2,559	0,669	0,866	1,102	1,339	2,835	8 x M6	10	13	841	13507	35784	20920	1	634	10226	27090	15837	1
40 x 65	1,575	2,559	0,669	0,866	1,102	1,339	2,835	8 x M6	10	13	885	13507	33995	20920	1	664	10226	25736	15837	1
42 x 75	1,654	2,953	0,787	0,984	1,299	1,614	3,228	8 x M8	26	30	1778	25870	52708	29516	2	1298	18894	38494	21557	2
45 x 75	1,772	2,953	0,787	0,984	1,299	1,614	3,228	8 x M8	26	30	1903	25870	49194	29516	1	1394	18894	35928	21557	2
48 x 80	1,890	3,150	0,787	0,984	1,299	1,614	3,425	8 x M8	26	30	2036	25870	46119	27672	2	1482	18894	33682	20209	2
50 x 80	1,969	3,150	0,787	0,984	1,299	1,614	3,425	8 x M8	26	30	2117	25870	44274	27672	2	1549	18894	32335	20209	2
55 x 85	2,165	3,346	0,787	0,984	1,299	1,614	3,622	8 x M8	26	30	2331	25870	40250	26044	2	1704	18894	29396	19021	2
60 x 90	2,362	3,543	0,787	0,984	1,299	1,614	3,819	8 x M8	26	30	2545	25870	36895	24597	2	1859	18894	26946	17964	2
65 x 95	2,559	3,740	0,787	0,984	1,299	1,614	4,016	9 x M8	26	30	3098	29104	38314	26215	2	2264	21256	27982	19146	2
70 x 110	2,756	4,331	0,945	1,181	1,575	1,969	4,606	8 x M10	52	61	4647	40583	41341	26308	4	3444	30000	30561	19448	4
75 x 115	2,953	4,528	0,945	1,181	1,575	1,969	4,803	8 x M10	52	61	4979	40583	38585	25164	4	3688	30000	28523	18602	4
80 x 120	3,150	4,724	0,945	1,181	1,575	1,969	5,000	8 x M10	52	61	5310	40583	36173	24115	4	3931	30000	26741	17827	4
85 x 125	3,346	4,921	0,945	1,181	1,575	1,969	5,197	10 x M10	52	61	7081	50728	42557	28939	4	5222	37500	31460	21393	4
90 x 130	3,543	5,118	0,945	1,181	1,575	1,969	5,394	10 x M10	52	61	7486	50728	40192	27826	5	5532	37500	29712	20570	5
95 x 135	3,740	5,315	0,945	1,181	1,575	1,969	5,591	10 x M10	52	61	7892	50728	38077	26795	5	5841	37500	28148	19808	5
100 x 145	3,937	5,709	1,024	1,260	1,732	2,205	5,984	8 x M12	92	107	9920	60397	39755	27417	6	7162	43680	28751	19828	7
110 x 155	4,331	6,102	1,024	1,260	1,732	2,205	6,378	8 x M12	92	107	10879	60397	36141	25648	7	7892	43680	26137	18549	7
120 x 165	4,724	6,496	1,024	1,260	1,732	2,205	6,772	9 x M12	92	107	13387	67947	37270	27106	7	9662	49140	26954	19603	7
130 x 180	5,118	7,087	1,339	1,575	2,126	2,598	7,362	12 x M12	92	107	19324	90596	35078	25334	11	13977	65520	25369	18322	11
140 x 190	5,512	7,480	1,339	1,575	2,126	2,677	7,756	9 x M14	140	170	20504	89338	32120	23668	11	15489	67424	24241	17862	12
150 x 200	5,906	7,874	1,339	1,575	2,126	2,677	8,150	10 x M14	140	170	24413	99265	33310	24982	12	18439	74916	25139	18854	13
160 x 210	6,299	8,268	1,339	1,575	2,126	2,677	8,543	12 x M14	140	170	31273	119118	37474	28551	13	23602	89899	28282	21548	13
170 x 225	6,693	8,858	1,732	1,969	2,520	3,071	9,134	12 x M14	140	170	33227	119118	27254	20592	18	25077	89899	20569	15541	18
180 x 235	7,087	9,252	1,732	1,969	2,520	3,071	9,528	12 x M14	140	170	35182	119118	25739	19715	18	26552	89899	19426	14879	19
190 x 250	7,480	9,843	1,732	1,969	2,520	3,071	10,118	15 x M14	140	170	46393	148897	30481	23166	21	35034	112374	23004	17483	22
200 x 260	7,874	10,236	1,732	1,969	2,520	3,071	10,512	15 x M14	140	170	48863	148897	28957	22275	22	36878	112374	21854	16811	23

For larger diameter please contact our application engineering department.

NOTE: it is possible to reduce the screws tightening torque down to 60% of the values indicated in the above table; as a result the M_t, F_{ax}, P_s, P_h are reduced proportionally.

TLK 134

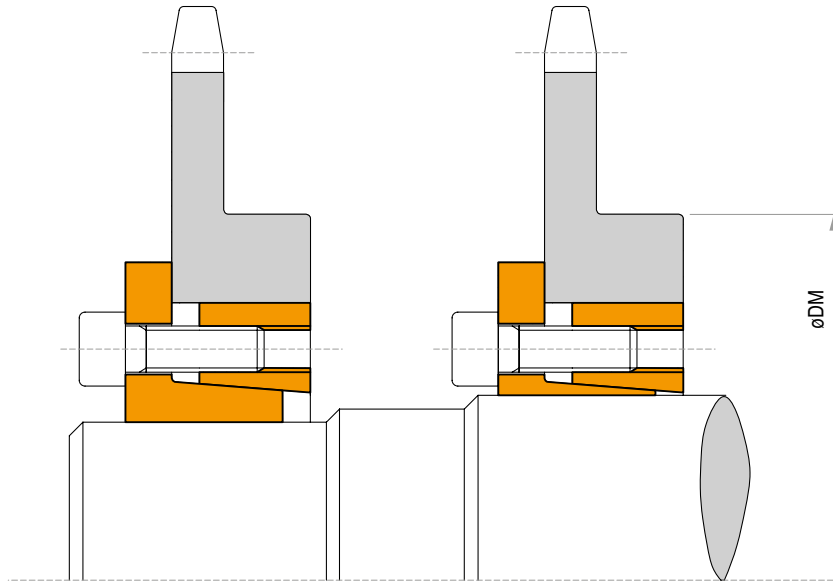

TLK 134 DIMENSIONS

Characteristics

- Medium torque
- Less numbers of screws than TLK133
- Quick installation
- One O.D. and multiple I.D.
- Solution for Sprockets and Pulleys

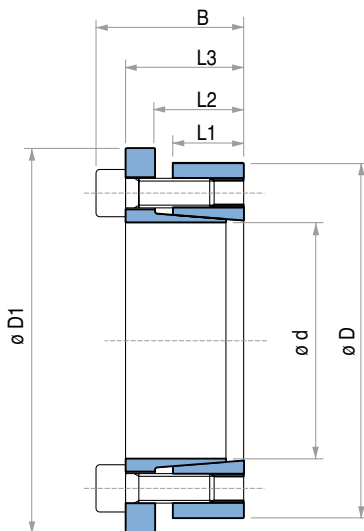

Dimensions								Torque	Axial force	Surface pressures on		Tightening screws		Weight
d x D	d	D	L1	L2	L3	B	D1			F _{ax}	p _s	p _h	DIN912 12.9	
mm	inch	inch	inch	inch	inch	inch	inch	M _t Lb-ft	Lbf	psi	psi	N° x Type	M _t Lb-ft	Lb
14 x 55	0,551	2,165	0,669	0,866	1,181	1,496	2,441	214	9447	67931	17291	4 x M8	30	1
16 x 55	0,630	2,165	17	22	30	38	62	251	9447	59440	17291	4 x M8	30	1
18 x 55	0,709	2,165	17	22	30	38	62	280	9447	52835	17291	4 x M8	30	1
19 x 55	0,748	2,165	17	22	30	38	62	295	9447	50054	17291	4 x M8	30	1
20 x 55	0,787	2,165	17	22	30	38	62	310	9447	47552	17291	4 x M8	30	1
22 x 55	0,866	2,165	17	22	30	38	62	339	9447	43229	17291	4 x M8	30	1
24 x 55	0,945	2,165	17	22	30	38	62	369	9447	39626	17291	4 x M8	30	1
25 x 55	0,984	2,165	17	22	30	38	62	391	9447	38041	17291	4 x M8	30	1
28 x 55	1,102	2,165	17	22	30	38	62	435	9447	33965	17291	4 x M8	30	1
30 x 55	1,181	2,165	17	22	30	38	62	465	9447	31701	17291	4 x M8	30	1
24 x 65	0,945	2,559	17	22	30	38	72	465	11809	49533	18289	5 x M8	30	2
25 x 65	0,984	2,559	17	22	30	38	72	487	11809	47552	18289	5 x M8	30	2
28 x 65	1,102	2,559	17	22	30	38	72	546	11809	42457	18289	5 x M8	30	1
30 x 65	1,181	2,559	17	22	30	38	72	583	11809	39626	18289	5 x M8	30	1
32 x 65	1,260	2,559	17	22	30	38	72	620	11809	37150	18289	5 x M8	30	1
35 x 65	1,378	2,559	17	22	30	38	72	679	11809	33965	18289	5 x M8	30	1
38 x 65	1,496	2,559	17	22	30	38	72	738	11809	31284	18289	5 x M8	30	1
40 x 65	1,575	2,559	17	22	30	38	72	774	11809	29720	18289	5 x M8	30	1
30 x 80	1,181	3,150	20	25	33	41	87	811	16532	47155	17683	7 x M8	30	2
32 x 80	1,260	3,150	20	25	33	41	87	870	16532	44208	17683	7 x M8	30	2
35 x 80	1,378	3,150	20	25	33	41	87	951	16532	40419	17683	7 x M8	30	2
38 x 80	1,496	3,150	20	25	33	41	87	1033	16532	37228	17683	7 x M8	30	2
40 x 80	1,575	3,150	20	25	33	41	87	1084	16532	35367	17683	7 x M8	30	2
42 x 80	1,654	3,150	20	25	33	41	87	1136	16532	33682	17683	7 x M8	30	2
45 x 80	1,772	3,150	20	25	33	41	87	1217	16532	31437	17683	7 x M8	30	2
48 x 80	1,890	3,150	20	25	33	41	87	1298	16532	29472	17683	7 x M8	30	2
50 x 80	1,969	3,150	20	25	33	41	87	1357	16532	28293	17683	7 x M8	30	2

TLK 136

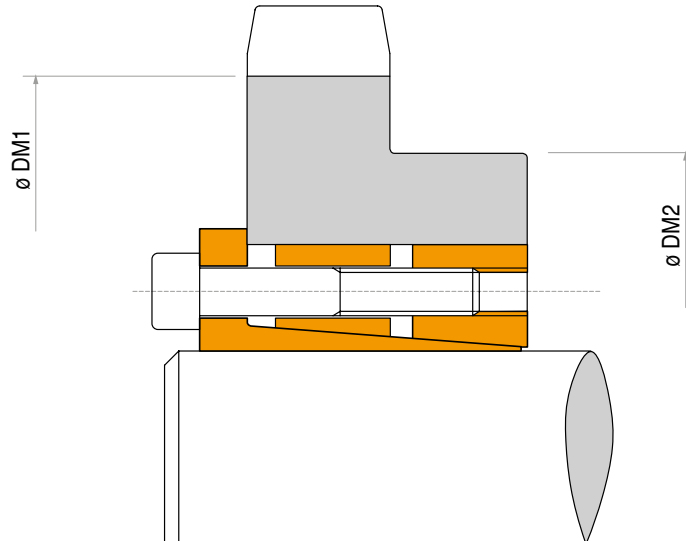

Characteristics

- High torque, high bending moments
- Excellent shaft-hub perpendicularity
- Low surface pressures
- Quick installation time

Installation

Carefully clean the hub and shaft contact surfaces and apply a thin film of light-weight oil. Slide the locking assembly onto shaft, insert them into the hub bore and tighten gradually and regularly in crossed sequence all screws (first the smaller screws, then the bigger ones) to reach the tightening torque M_s as indicated in the table. The values M_t and F_{ax} indicated in the table are valid only in case of oil installation. Do not use any oil with molybdenum bisulphide or high pressure additives and not grease. Above substances notably reduce the friction coefficient.

Dismantling

Loosen the small screws for some turn only and loosen completely the big screws. Insert the big screws into the dismantling threading and tighten gradually and regularly in crossed sequence until the cones are released. If the element is to be reused, relubricate both screws and threads.

Tolerances, surface finish

A good surface finish by machine tool is sufficient.
Maximum allowable surface finish:
 R_t max $16 \mu\text{m}$ (R_a $3 \mu\text{m}$ - R_z $13 \mu\text{m}$)

Maximum permissible tolerances:
h8 for shaft
H8 for hub

Axial movement

TLK 136: during screws tightening the hub has no axial movement with respect to the shaft.

DM hub calculation

The pressure P_n in the hub can be compared to the inside pressure on a thick hollow cylinder.

For DM calculation see page 54.

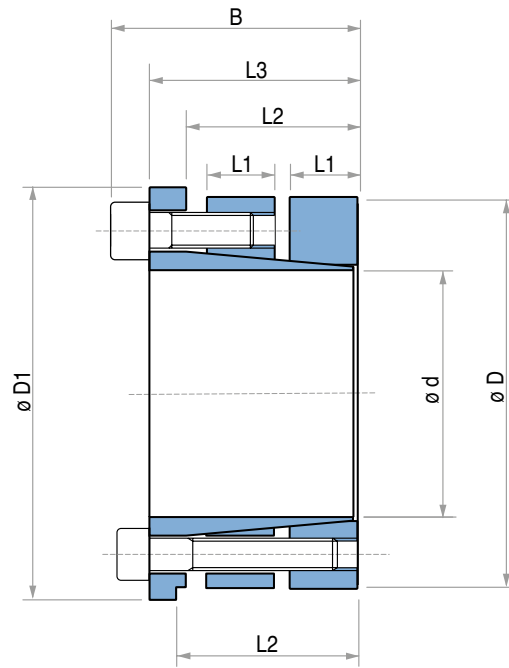

* For diameters > 420 mm.

TLK 136 DIMENSIONS

Dimensions								Torque			Axial force			Surface pressures on				Tightening screws 1		Tightening screws 2		Weight
d x D	d	D	L1	L2	L3	B	D1	M ₁	M ₂	M _{tot}	F _{ax1}	F _{ax2}	F _{ax tot}	p _{s1}	p _{s2}	p _{h1}	p _{h2}	DIN912 12.9	Tightening torque	DIN912 12.9	Tightening torque	
mm	inch	inch	inch	inch	inch	inch	inch	Lb-Ft	Lb-Ft	Lb-Ft	Lbf	Lbf	Lbf	psi	psi	psi	psi	N° x Type	M _t Lb-Ft	N° x Type	M _t Lb-Ft	Lb
100 x 150	3,9370	5,906	1,024	2,402	3,228	3,780	6,260	8556	6269	14825	172	125	297	34519	25237	23061	16824	7 x M14	170	7 x M12	107	14
110 x 160	4,3307	6,299	1,024	2,402	3,228	3,780	6,654	9441	6859	16300	172	125	297	31473	22916	21611	15809	7 x M14	170	7 x M12	107	15
120 x 170	4,7244	6,693	1,024	2,402	3,228	3,780	7,047	10252	7523	17775	172	125	297	28863	21030	20305	14939	7 x M14	170	7 x M12	107	16
130 x 190	5,1181	7,480	1,181	2,795	3,740	4,370	7,835	17701	12686	30388	273	196	469	36695	26397	25092	18130	8 x M16	262	8 x M14	170	24
140 x 200	5,5118	7,874	1,181	2,795	3,740	4,370	8,228	19103	13719	32822	273	196	469	34084	24511	23786	17114	8 x M16	262	8 x M14	170	26
150 x 210	5,9055	8,268	1,181	2,795	3,740	4,370	8,622	20430	14677	35108	273	196	469	31763	22916	22771	16389	8 x M16	262	8 x M14	170	28
160 x 220	6,2992	8,661	1,181	2,795	3,740	4,370	9,016	21832	15636	37468	273	196	469	29733	21466	21611	15664	8 x M16	262	8 x M14	170	29
170 x 240	6,6929	9,449	1,575	3,622	4,803	5,591	9,803	36214	23159	59374	426	273	699	32779	21030	23206	14939	8 x M20	509	8 x M16	262	47
180 x 250	7,0866	9,843	1,575	3,622	4,803	5,591	10,197	38353	24561	62914	426	273	699	31038	19870	22336	14359	8 x M20	509	8 x M16	262	49
190 x 260	7,4803	10,236	1,575	3,622	4,803	5,591	10,591	40492	25888	66381	426	273	699	29298	18855	21466	13779	8 x M20	509	8 x M16	262	51
200 x 270	7,8740	10,630	1,575	3,622	4,803	5,591	10,984	53252	34149	87401	533	341	874	34809	22336	25817	16534	10 x M20	509	10 x M16	262	54
220 x 290	8,6614	11,417	1,575	3,622	4,803	5,591	11,772	58562	37542	96104	533	341	874	31618	20305	24076	15374	10 x M20	509	10 x M16	262	58
240 x 310	9,4488	12,205	1,575	3,622	4,803	5,591	12,559	76706	49122	125828	639	409	1049	34809	22336	26977	17259	12 x M20	509	12 x M16	262	63
260 x 330	10,2362	12,992	1,575	3,622	4,803	5,591	13,346	83123	53178	136301	639	409	1049	32198	20595	25382	16244	12 x M20	509	12 x M16	262	68
280 x 365	11,0236	14,370	1,772	4,252	5,669	6,614	14,724	107242	74494	181735	766	533	1299	31763	22191	24366	16969	10 x M24	885	10 x M20	509	103
300 x 385	11,8110	15,157	1,772	4,252	5,669	6,614	15,512	114912	79878	194790	766	533	1299	29733	20740	23206	16099	10 x M24	885	10 x M20	509	109
320 x 405	12,5984	15,945	1,772	4,252	5,669	6,614	16,299	147144	102300	249444	920	639	1559	33359	23206	26397	18420	12 x M24	885	12 x M20	509	116
340 x 425	13,3858	16,732	1,772	4,252	5,669	6,614	17,087	182252	126861	309112	1072	746	1819	36695	25527	29298	20450	14 x M24	885	14 x M20	509	121
360 x 445	14,1732	17,520	1,772	4,252	5,669	6,614	17,874	193020	134310	327330	1072	746	1819	34664	24076	27992	19580	14 x M24	885	14 x M20	509	129
380 x 465	14,9606	18,307	1,772	4,252	5,669	6,614	18,661	232848	161969	394817	1226	853	2078	37420	26107	30603	21321	16 x M24	885	16 x M20	509	136
400 x 485	15,7480	19,094	1,772	4,252	5,669	6,614	19,449	245166	170524	415690	1226	853	2078	35679	24801	29443	20450	16 x M24	885	16 x M20	509	142
420 x 505	16,5354	19,882	1,772	4,252	5,669	6,614	20,236	257409	179006	436416	1226	853	2078	33939	23641	28282	19725	16 x M24	885	16 x M20	509	149
440 x 525	17,3228	20,669	2,323	5,787	7,008	7,953	21,024	269653	187562	457215	1226	853	2078	24656	20740	17259	14504	16 x M24	885	16 x M20	509	190
460 x 545	18,1102	21,457	2,323	5,787	7,008	7,953	21,811	281896	196044	477940	1226	853	2078	23641	20015	16534	13924	16 x M24	885	16 x M20	509	197
480 x 565	18,8976	22,244	2,323	5,787	7,008	7,953	22,598	294140	204600	498740	1226	853	2078	22626	19290	15809	13489	16 x M24	885	16 x M20	509	205
500 x 585	19,6850	23,031	2,323	5,787	7,008	7,953	23,386	344810	239855	584665	1379	960	2339	24511	20885	17114	14649	18 x M24	885	18 x M20	509	213
520 x 605	20,4724	23,819	2,323	5,787	7,008	7,953	24,173	358603	249444	608046	1379	960	2339	23496	20305	16389	14069	18 x M24	885	18 x M20	509	220
540 x 625	21,2598	24,606	2,323	5,787	7,008	7,953	24,961	372395	259032	631427	1379	960	2339	22626	19580	15809	13634	18 x M24	885	18 x M20	509	229
560 x 645	22,0472	25,394	2,323	5,787	7,008	7,953	25,748	386188	268620	654808	1379	960	2339	21901	19000	15229	13198	18 x M24	885	18 x M20	509	236
580 x 665	22,8346	26,181	2,323	5,787	7,008	7,953	26,535	444455	309039	753493	1533	1066	2598	23496	20450	16389	14214	20 x M24	885	20 x M20	509	245
600 x 685	23,6220	26,969	2,323	5,787	7,008	7,953	27,323	459796	319733	779529	1533	1066	2598	22626	19870	15809	13779	20 x M24	885	20 x M20	509	251

For other dimensions, please contact us.

TLK 138

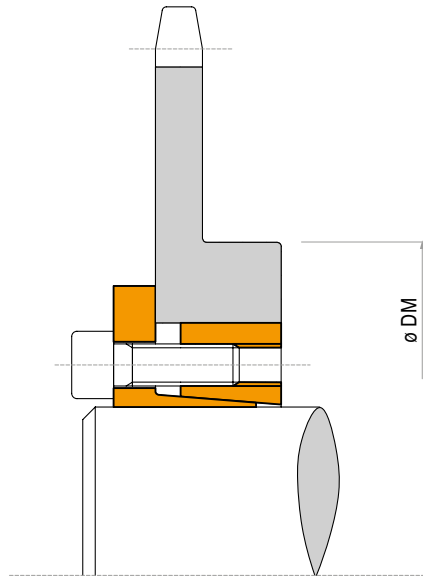

Characteristics

- Medium-low torque
- Quick installation time, compact size
- Application economically advantageous
- Excellent for inch hub i.d.

Carefully clean the hub and shaft contact surfaces and apply a thin film of light-weight oil. Slide the locking assembly into the hub bore, insert the shaft and tighten all screws gradually and regularly in crossed sequence to reach the tightening torque M_s as indicated in the rating table.

The values M_t and F_{ax} indicated in the rating table are valid only in case of oil installation. Do not use any oil with **molibdenum bisulphide**, high pressure additives or grease. Above substances notably reduce the coefficient of friction. For additional information on installation refer to page 58.

Dismantling

Loosen the clamping screws. Insert the screws into the dismantling threading and tighten gradually and regularly in crossed sequence until the back cone is released. If the element is to be reused, relubricate both screws and threadings. For additional information on dismantling refer to page 58.

Tolerances, surface finish

A good surface finish by machine tool is sufficient.
Maximum allowable surface finish:
Rt max 16 μm (Ra 3 μm - Rz 13 μm)

Maximum permissible tolerances:

h8 for shaft
H8 for hub

Axial movement

TLK 138: during screws tightening the hub has no axial movement with respect to the shaft.

DM hub calculation

The pressure P_n in the hub can be compared to the inside pressure on a thick hollow cylinder.

For DM calculation see page 54.

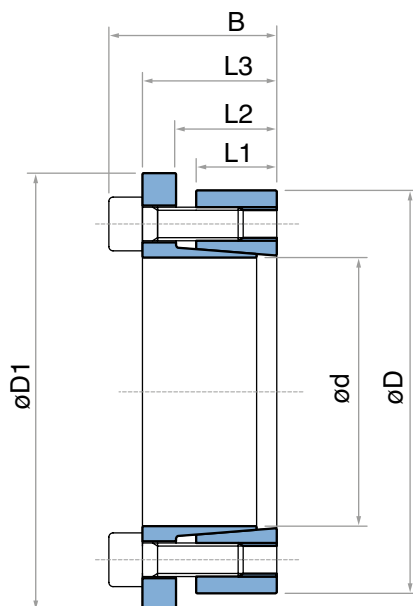

TLK 138 DIMENSIONS

Dimensions								Torque	Axial force	Surface pressures on		Tightening screws		Weight
d mm	d inch	D inch	L1 inch	L2 inch	L3 inch	B inch	D1 inch			P_s psi	P_h psi	DIN912 12.9	Tightening torque	
d mm	d inch	D inch	L1 inch	L2 inch	L3 inch	B inch	D1 inch	M_t Lb-ft	F_{ax} Lbf	P_s psi	P_h psi	N° x Type	M_t Lb-ft	Lb
1/4	0,2500	0,8125	0,394	0,512	0,650	0,807	0,9375	175	1663	44830	13794	3 x M4	4	0,1
5/16	0,3125	0,8750	0,394	0,512	0,650	0,807	1,0000	263	1663	35864	12809	3 x M4	4	0,1
3/8	0,3750	0,9375	0,394	0,512	0,650	0,807	1,0625	350	1663	29887	11955	3 x M4	4	0,1
1/2	0,5000	1,0625	0,394	0,512	0,650	0,807	1,1875	526	2218	29887	14064	4 x M4	4	0,1
5/8	0,6250	1,1875	0,472	0,591	0,728	0,886	1,3125	1051	3327	29887	15730	6 x M4	4	0,2
3/4	0,7500	1,3125	0,472	0,591	0,728	0,886	1,4375	1227	3327	24906	14232	6 x M4	4	0,2
7/8	0,8750	1,5625	0,591	0,748	0,984	1,181	1,7500	2366	5435	27899	15623	6 x M4	7	0,4
1	1,0000	1,6875	0,591	0,748	0,984	1,181	1,8750	3592	7246	32548	19288	8 x M5	7	0,4
1 1/8	1,1250	1,8750	0,669	0,827	1,063	1,260	2,0000	4556	8152	28719	17231	9 x M5	7	0,6
1 3/16	1,1875	1,9375	0,669	0,827	1,063	1,260	2,0625	5345	9058	30231	18528	10 x M5	7	0,6
1 1/4	1,2500	2,0000	0,669	0,827	1,063	1,260	2,1250	5608	9058	28719	17949	10 x M5	7	0,6
1 3/8	1,3750	2,1250	0,669	0,827	1,063	1,260	2,2500	6134	9058	26108	16894	10 x M5	7	0,6

Dimensions								Torque	Axial force	Surface pressures on		Tightening screws		Weight
d mm	d inch	D inch	L1 inch	L2 inch	L3 inch	B inch	D1 inch			P_s psi	P_h psi	DIN912 12.9	Tightening torque	
d mm	d inch	D inch	L1 inch	L2 inch	L3 inch	B inch	D1 inch	M_t Lb-ft	F_{ax} Lbf	P_s psi	P_h psi	N° x Type	M_t Lb-ft	Lb
6	0,236	0,8125	0,394	0,512	0,650	0,807	0,9375	175	1663	47445	13794	3 x M4	4	0,1
8	0,315	0,8750	0,394	0,512	0,650	0,807	1,0000	263	1663	35584	12809	3 x M4	4	0,1
10	0,394	0,9375	0,394	0,512	0,650	0,807	1,0625	350	1663	28467	11955	3 x M4	4	0,1
12	0,472	1,0625	0,394	0,512	0,650	0,807	1,1875	526	2218	31630	14064	4 x M4	4	0,1
14	0,551	1,0625	0,394	0,512	0,650	0,807	1,1875	613	2218	27111	14064	4 x M4	4	0,1
15	0,591	1,1875	0,472	0,591	0,787	0,945	1,3125	964	3327	31630	15730	6 x M4	4	0,2
16	0,630	1,1875	0,472	0,591	0,787	0,945	1,3125	1051	3327	29653	15730	6 x M4	4	0,2
19	0,748	1,3125	0,472	0,591	0,787	0,945	1,4375	1227	3327	24971	14232	6 x M4	4	0,2
20	0,787	1,5625	0,591	0,748	0,984	1,181	1,7500	2103	5435	31002	15623	6 x M4	7	0,4
22	0,866	1,5625	0,591	0,748	0,984	1,181	1,7500	2366	5435	28184	15623	6 x M4	7	0,4
24	0,945	1,6875	0,591	0,748	0,984	1,181	1,8750	3417	7246	34447	19288	8 x M5	7	0,4
25	0,984	1,6875	0,591	0,748	0,984	1,181	1,8750	3505	7246	33069	19288	8 x M5	7	0,4
28	1,102	1,8750	0,669	0,827	1,063	1,260	2,0000	4469	8152	29309	17231	9 x M5	7	0,6
30	1,181	1,9375	0,669	0,827	1,063	1,260	2,0625	5257	9058	30394	18528	10 x M5	7	0,6
32	1,260	2,0000	0,669	0,827	1,063	1,260	2,1250	5608	9058	28495	17949	10 x M5	7	0,6
35	1,378	2,1250	0,669	0,827	1,063	1,260	2,2500	6221	9058	26052	16894	10 x M5	7	0,6

TLK 139

TLK 139 DIMENSIONS

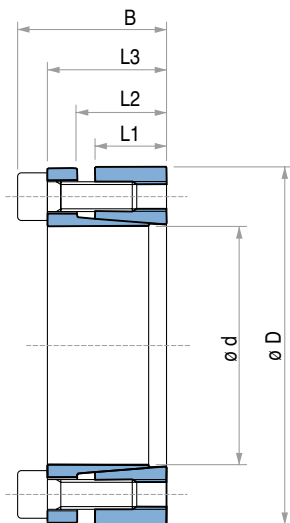

Dimensions							Torque	Axial force	Surface pressures on		Tightening screws		Weight
d x D	d	D	L1	L2	L3	B			M _t	F _{ax}	P _s	P _n	
mm	inch	inch	inch	inch	inch	inch	Lb-ft	Lbf	psi	psi		Lb-ft	
18 x 40	0,709	1,575	0,472	0,591	0,787	0,945	155	5328	33794	19000	6 x M4	4	0,4
19 x 41	0,748	1,614	0,472	0,591	0,787	0,945	162	5328	32053	18565	6 x M4	4	0,4
20 x 42	0,787	1,654	0,472	0,591	0,787	0,945	199	6227	35534	21176	7 x M4	4	0,4
22 x 44	0,866	1,732	0,472	0,591	0,787	0,945	221	6227	32343	20160	7 x M4	4	0,4
24 x 46	0,945	1,811	0,472	0,591	0,787	0,945	243	6227	29588	19290	7 x M4	4	0,4
25 x 47	0,984	1,850	0,472	0,591	0,787	0,945	251	6227	28427	18855	7 x M4	4	0,4
28 x 50	1,102	1,969	0,472	0,591	0,787	0,945	369	8003	32633	22771	9 x M4	4	0,4
30 x 52	1,181	2,047	0,472	0,591	0,787	0,945	391	8003	30458	21901	9 x M4	4	0,4
32 x 54	1,260	2,126	0,472	0,591	0,787	0,945	420	8003	28572	21176	9 x M4	4	0,4
35 x 57	1,378	2,244	0,630	0,748	0,945	1,102	509	8880	22916	16679	10 x M4	4	0,7
36 x 58	1,417	2,283	0,630	0,748	0,945	1,102	524	8880	22191	16389	10 x M4	4	0,7
38 x 60	1,496	2,362	0,630	0,748	0,945	1,102	612	9779	23206	17405	11 x M4	4	0,7
40 x 62	1,575	2,441	0,630	0,748	0,945	1,102	642	9779	22046	16824	11 x M4	4	0,9
42 x 70	1,654	2,756	0,748	0,906	1,181	1,417	1128	16411	29008	21176	8 x M6	13	1,3
45 x 73	1,772	2,874	0,748	0,906	1,181	1,417	1210	16411	27122	20305	8 x M6	13	1,3
48 x 76	1,890	2,992	0,748	0,906	1,181	1,417	1291	16411	25382	19435	8 x M6	13	1,3
50 x 78	1,969	3,071	0,748	0,906	1,181	1,417	1342	16411	24366	19000	8 x M6	13	1,3
55 x 83	2,165	3,268	0,748	0,906	1,181	1,417	1475	16411	22191	17840	8 x M6	13	1,5
56 x 84	2,205	3,307	0,748	0,906	1,181	1,417	1505	16411	21756	17550	8 x M6	13	1,5
60 x 88	2,362	3,465	0,748	0,906	1,181	1,417	1814	18457	22916	18855	9 x M6	13	1,5
63 x 91	2,480	3,583	0,748	0,906	1,181	1,417	1903	18457	21756	18275	9 x M6	13	2,0
65 x 93	2,559	3,661	0,748	0,906	1,181	1,417	1962	18457	21176	17840	9 x M6	13	2,2
70 x 105	2,756	4,134	0,906	1,102	1,457	1,772	3481	30304	26542	21466	8 x M8	30	3,3
75 x 110	2,953	4,331	0,906	1,102	1,457	1,772	3725	30304	24656	20450	8 x M8	30	3,3
80 x 115	3,150	4,528	0,906	1,102	1,457	1,772	3975	30304	23206	19580	8 x M8	30	3,7
85 x 120	3,346	4,724	0,906	1,102	1,457	1,772	4226	30304	21756	18855	8 x M8	30	4,4
90 x 125	3,543	4,921	0,906	1,102	1,457	1,772	5591	37880	25672	22626	10 x M8	30	5,1

Characteristics

- Medium-low torque
- Limited installation time
- Application economically advantageous

Installation

Carefully clean the hub and shaft contact surfaces and apply a light oil film. Slide the locking assembly into the hub bore, insert the shaft and tighten gradually and regularly in crossed sequence all screws to reach the tightening torque M_t as indicated in the table.

The values M_t and F_{ax} indicated in the table are valid only in case of oil installation. Do not use any oil with **molibdenum bisulphide** or high pressure additives and not grease. Above substances notably reduce the friction coefficient. For additional information on installation refer to page 58.

Dismantling

Loosen the clamping screws. Insert the screws into the dismantling threading and tighten gradually and regularly in crossed sequence until the back cone is released. If the element is to be reused, relubricate both screws and threadings. For additional information on dismantling refer to page 58.

Tolerances, surface finish

A good surface finish by the machine tool is sufficient. Maximum allowable surface finish:
Rt max 16 μm (Ra 3 μm - Rz 13 μm)

Maximum permissible tolerances:

h8 for shaft

H8 for hub

For exact tolerance values see page 57.

Axial movement

TLK 139: during screws tightening the hub has a slight axial movement with respect to the shaft.

DM hub calculation

The pressure P_n in the hub can be compared to the inside pressure on a thick hollow cylinder.

For DM calculation see page 54.

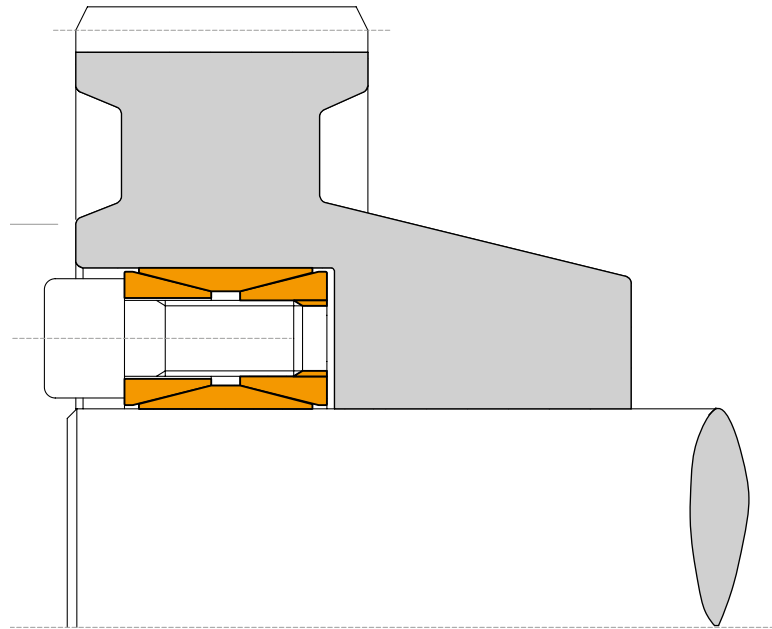

Characteristics

- Medium-high torque
- Wide tolerances
- Compact size
- Easy dismantling

Installation

Carefully clean the hub and shaft contact surfaces and apply a light oil film. Slide the locking assembly into the hub bore and insert the shaft. Tighten cadmium plated clamping screws until inner ring grips the shaft and the outer ring grips the hub bore then tighten gradually and regularly in crossed sequence all screws to reach the tightening torque M_s indicated in the table.

The values M_t and F_{ax} indicated in the table are valid only in case of oil installation. Do not use any oil with **molibdenum bisulphide** or high pressure additives and not grease.

Dismantling

By loosening all tightening screws the clamping unit is normally released. In case of difficulties slightly hammer the released screws to push back the rear pressure cone. For additional information on dismantling refer to page 58.

Tolerances, surface finish

A good surface finish by machine tool is sufficient.
Maximum allowable surface finish:
Rt max 16 μm (Ra 3 μm - Rz 13 μm)

Maximum permissible tolerances:
h11 for shaft
H11 for hub

Centering

Mod. TLK 200 is not self-centering. The hub concentricity with respect to the shaft depends on the guide surface tolerance and its length.

Axial movement

TLK 200: during screws tightening the hub has no axial movement with respect to the shaft.

DM hub calculation

The pressure P_n in the hub can be compared to the inside pressure on a thick hollow cylinder.

For DM calculation see page 54.

M_t transmissible

If two or more clamping unit are installed together, as a result of carried tests, the M_t transmissible shall be calculated as follow:

Nr. 1 TLK 200	$M_t = M_t \text{ cat.}$
Nr. 2 TLK 200	$M_t = M_t \text{ cat.} \cdot 1,9$
Nr. 3 TLK 200	$M_t = M_t \text{ cat.} \cdot 2,7$

TLK 200 DIMENSIONS

Dimensions						Shaft / Hub tolerances h11 / H11				Shaft / Hub tolerances h7 / H7		Tightening screws		Weight
						Torque	Axial force	Surface pressures on		Torque	pressures on Hub	DIN912 12.9	Tightening torque	
								Shaft	Hub					
d x D mm	d inch	D inch	L1 inch	L2 inch	B inch	M _t Lb-ft	F _{ax} lbf	P _s psi	P _h psi	M _t Lb-ft	P _h psi	N° x Type	M _t Lb-ft	Lb
17 x 47	0,669	1,850	0,669	0,787	1,024	207	7419	44237	15954	229	18130	8 x M6	13	0,4
18 x 47	0,709	1,850	0,669	0,787	1,024	221	7419	42061	15954	243	18130	8 x M6	13	0,4
19 x 47	0,748	1,850	0,669	0,787	1,024	229	7419	39885	15954	258	18130	8 x M6	13	0,4
20 x 47	0,787	1,850	0,669	0,787	1,024	243	7419	37710	15954	273	18130	8 x M6	13	0,4
22 x 47	0,866	1,850	0,669	0,787	1,024	266	7419	34084	15954	302	18130	8 x M6	13	0,4
24 x 50	0,945	1,969	0,669	0,787	1,024	288	7419	31183	15229	325	16679	8 x M6	13	0,7
25 x 50	0,984	1,969	0,669	0,787	1,024	302	7419	29733	15229	339	16679	8 x M6	13	0,7
28 x 55	1,102	2,165	0,669	0,787	1,024	420	9217	33359	16679	479	18855	10 x M6	13	0,7
30 x 55	1,181	2,165	0,669	0,787	1,024	450	9217	31183	16679	509	18855	10 x M6	13	0,7
32 x 60	1,260	2,362	0,669	0,787	1,024	575	11016	34809	18855	656	21030	12 x M6	13	0,7
35 x 60	1,378	2,362	0,669	0,787	1,024	627	11016	31908	18130	715	21030	12 x M6	13	0,7
38 x 65	1,496	2,559	0,669	0,787	1,024	789	12814	34084	19580	907	22481	14 x M6	13	0,9
40 x 65	1,575	2,559	0,669	0,787	1,024	826	12589	31908	19580	959	22481	14 x M6	13	0,7
42 x 75	1,654	2,953	0,787	0,945	1,260	1372	20008	40611	22481	1601	26832	12 x M8	30	1
45 x 75	1,772	2,953	0,787	0,945	1,260	1468	20008	37710	22481	1711	26832	12 x M8	30	1
48 x 80	1,890	3,150	0,787	0,945	1,260	1564	19783	35534	21030	1829	24656	12 x M8	30	1
50 x 80	1,969	3,150	0,787	0,945	1,260	1623	19783	34084	21030	1903	24656	12 x M8	30	1
55 x 85	2,165	3,346	0,787	0,945	1,260	2073	22931	35534	23206	2441	27557	14 x M8	30	1
60 x 90	2,362	3,543	0,787	0,945	1,260	2250	22931	32633	21756	2663	26107	14 x M8	30	2
65 x 95	2,559	3,740	0,787	0,945	1,260	2781	26078	34084	23206	3297	27557	16 x M8	30	2
70 x 110	2,756	4,331	0,945	1,102	1,496	4130	35969	36985	23206	4942	27557	14 x M10	61	3
75 x 115	2,953	4,528	0,945	1,102	1,496	4403	35745	34084	22481	5288	26832	14 x M10	61	3
80 x 120	3,150	4,724	0,945	1,102	1,496	4669	35520	31908	21030	5642	25382	14 x M10	61	3
85 x 125	3,346	4,921	0,945	1,102	1,496	5650	40466	34084	23206	6852	28282	16 x M10	61	3
90 x 130	3,543	5,118	0,945	1,102	1,496	5960	40466	31908	22481	7258	26832	16 x M10	61	3
95 x 135	3,740	5,315	0,945	1,102	1,496	7051	45187	34084	23931	8556	29008	18 x M10	61	4
100 x 145	3,937	5,709	1,024	1,299	1,772	8334	51032	33359	23206	10252	28282	14 x M12	107	5
110 x 155	4,331	6,102	1,024	1,299	1,772	9146	50807	30458	21756	11285	26832	14 x M12	107	6
120 x 165	4,724	6,496	1,024	1,299	1,772	11358	58001	31908	23206	14087	28282	16 x M12	107	6
130 x 180	5,118	7,087	1,339	1,496	1,969	15341	71939	27557	20305	19029	25382	20 x M12	107	8
140 x 190	5,512	7,480	1,339	1,496	1,969	18070	78908	28282	21030	22569	26107	22 x M12	107	9
150 x 200	5,906	7,874	1,339	1,496	1,969	21021	85652	29008	21756	26405	26832	24 x M12	107	9
160 x 210	6,299	8,268	1,339	1,496	1,969	24266	92396	29008	22481	30535	27557	26 x M12	107	9
170 x 225	6,693	8,858	1,496	1,732	2,283	29798	107009	28282	21756	37616	26832	22 x M14	170	13
180 x 235	7,087	9,252	1,496	1,732	2,283	34297	116451	29008	22481	43516	28282	24 x M14	170	13
190 x 250	7,480	9,843	1,811	2,047	2,598	42189	135335	26832	20305	53547	25382	28 x M14	170	19
200 x 260	7,874	10,236	1,811	2,047	2,598	47351	144552	26832	21030	60406	26107	30 x M14	170	19
220 x 285	8,661	11,220	1,969	2,205	2,835	62324	172878	26832	21030	80025	26832	26 x M16	262	24
240 x 305	9,449	12,008	1,969	2,205	2,835	78182	198731	28282	22481	100751	29008	30 x M16	262	26
260 x 320	10,236	12,795	1,969	2,205	2,835	95367	223685	29733	23206	123763	30458	34 x M16	262	29
280 x 355	11,024	13,976	2,362	2,598	3,307	115945	252460	25382	20305	150905	26107	32 x M18	358	42
300 x 375	11,811	14,764	2,362	2,598	3,307	138809	282135	26832	21756	181957	28282	36 x M18	358	44
320 x 405	12,598	15,945	2,835	3,071	3,858	191324	364640	26832	21756	251804	28282	36 x M20	509	66
340 x 425	13,386	16,732	2,835	3,071	3,858	202461	363066	25382	20305	267514	26832	36 x M20	509	66
360 x 455	14,173	17,913	3,307	3,543	4,409	265744	450068	25382	20305	352628	26832	36 x M22	686	93
380 x 475	14,961	18,701	3,307	3,543	4,409	279315	448269	23931	19580	372174	25382	36 x M22	686	97
400 x 495	15,748	19,488	3,307	3,543	4,409	292812	446246	22481	18130	391793	24656	36 x M22	686	101
420 x 515	16,535	20,276	3,307	3,543	4,409	340606	494355	23931	19580	457067	26107	40 x M22	686	110
440 x 545	17,323	21,457	3,780	4,016	4,961	410970	569441	23206	18855	552950	25382	40 x M24	885	143
460 x 565	18,110	22,244	3,780	4,016	4,961	428376	567867	21756	18130	578101	23931	40 x M24	885	148
480 x 585	18,898	23,031	3,780	4,016	4,961	468057	594395	21756	18130	633418	24656	42 x M24	885	157
500 x 605	19,685	23,819	3,780	4,016	4,961	509287	620922	22481	18130	691243	24656	44 x M24	885	161
520 x 630	20,472	24,803	3,780	4,016	4,961	540190	633287	21756	18130	735202	24656	45 x M24	885	176
540 x 650	21,260	25,591	3,780	4,016	4,961	560178	632388	21030	17405	763377	23931	45 x M24	885	181
560 x 670	22,047	26,378	3,780	4,016	4,961	617856	672628	21756	18130	844509	24656	48 x M24	885	187
580 x 690	22,835	27,165	3,780	4,016	4,961	665650	699605	21756	18130	910889	24656	50 x M24	885	194
600 x 710	23,622	27,953	3,780	4,016	4,961	686597	697582	21030	17405	942604	23931	50 x M24	885	201
620 x 730	24,409	28,740	3,780	4,016	4,961	735718	723435	21030	17405	1012673	24656	52 x M24	885	205
640 x 750	25,197	29,528	3,780	4,016	4,961	786979	750187	21030	18130	1085691	24656	54 x M24	885	212
660 x 770	25,984	30,315	3,780	4,016	4,961	840821	776940	21030	18130	1160923	24656	56 x M24	885	218
680 x 790	26,772	31,102	3,780	4,016	4,961	865160	775591	20305	17405	1196326	23931	56 x M24	885	225
700 x 810	27,559	31,890	3,780	4,016	4,961	951455	828646	21030	18130	1319499	25382	60 x M24	885	229
720 x 830	28,346	32,677	3,780	4,016	4,961	977270	827522	20305	18130	1357114	24656	60 x M24	885	236
740 x 850	29,134	33,465	3,780	4,016	4,961	1036275	853824	20305	18130	1441196	24656	62 x M24	885	243
760 x 870	29,921	34,252	3,780	4,016	4,961	1096755	880127	20305	18130	1528229	25382	64 x M24	885	249
780 x 890	30,709	35,039	3,780	4,016	4,961	1141746	892492	20305	18130	1592397	24656	65 x M24	885	256
800 x 910	31,496	35,827	3,780	4,016	4,961	1187475	904856	20305	17405	1658777	24656	66 x M24	885	260

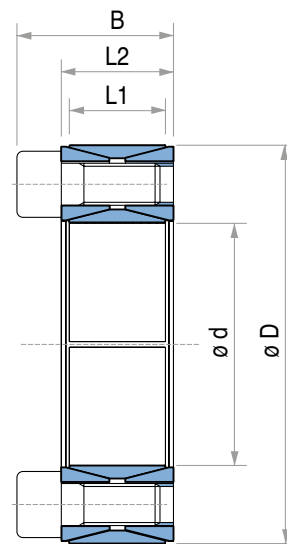

TLK 200 DIMENSIONS

Dimensions						Shaft / Hub tolerances h11 / H11				Shaft / Hub tolerances h7 / H7		Tightening screws		Weight
						Torque	Axial force	Surface pressures on		Torque	pressures on Hub	DIN912 12.9	Tightening torque	
								Shaft	Hub					
d inch	d inch	D inch	L1 inch	L2 inch	B inch	M _t Lb-ft	F _{ax} Lbf	P _s psi	P _h psi	M _t Lb-ft	P _h psi	N° x Type	M _t Lb-ft	Lb
3/4	0,7500	1,850	0,669	0,787	1,024	228	7501	39886	15955	243	16680	8 x M6	13	0,4
7/8	0,8750	1,850	0,669	0,787	1,024	272	7501	34084	15955	287	16680	8 x M6	13	0,4
1	1,0000	1,969	0,669	0,787	1,024	309	7456	29733	15229	324	15955	8 x M6	13	0,7
1 1/8	1,1250	2,165	0,669	0,787	1,024	427	9266	32634	16680	464	18130	10 x M6	13	0,7
1 3/16	1,1875	2,159	0,669	0,787	1,024	457	9244	31184	16680	486	18130	10 x M6	13	0,7
1 1/4	1,2500	2,362	0,669	0,787	1,024	567	11039	34810	18855	619	20306	12 x M6	13	0,7
1 3/8	1,3750	2,365	0,669	0,787	1,024	626	10986	31909	18130	678	20306	12 x M6	13	0,7
1 7/16	1,4375	2,559	0,669	0,787	1,024	759	12740	34810	19581	826	21756	14 x M6	13	0,9
1 1/2	1,5000	2,559	0,669	0,787	1,024	789	12740	33359	19581	862	21756	14 x M6	13	0,7
1 5/8	1,6250	2,953	0,787	0,945	1,260	1349	20006	41336	22481	1489	25382	12 x M8	30	1
1 11/16	1,6875	2,953	0,787	0,945	1,260	1401	19933	39886	22481	1541	25382	12 x M8	30	1
1 3/4	1,7500	2,953	0,787	0,945	1,260	1452	19933	38436	22481	1600	25382	12 x M8	30	1
1 7/8	1,8750	3,150	0,787	0,945	1,260	1548	19860	35535	21031	1718	23207	12 x M8	30	1
1 15/16	1,9375	3,150	0,787	0,945	1,260	1593	19811	34810	21031	1770	23207	12 x M8	30	1
2	2,0000	3,346	0,787	0,945	1,260	1917	23027	38436	23207	2138	26107	14 x M8	30	1
2 1/8	2,1250	3,346	0,787	0,945	1,260	2035	23027	36260	23207	2271	26107	14 x M8	30	1
2 3/16	2,1875	3,543	0,787	0,945	1,260	2087	22913	35535	21756	2338	24657	14 x M8	30	2
2 1/4	2,2500	3,543	0,787	0,945	1,260	2146	22913	34084	21756	2404	24657	14 x M8	30	2
2 3/8	2,3750	3,531	0,787	0,945	1,260	2264	22913	32634	21756	2537	24657	14 x M8	30	2
2 7/16	2,4375	3,740	0,787	0,945	1,260	2647	26088	36260	23207	2979	26107	16 x M8	30	2
2 1/2	2,5000	3,740	0,787	0,945	1,260	2714	26088	34810	23207	3053	26107	16 x M8	30	2
2 9/16	2,5625	3,737	0,787	0,945	1,260	2780	26088	34084	23207	3127	26107	16 x M8	30	2
2 5/8	2,6250	4,331	0,945	1,102	1,496	3931	35974	38436	23207	4454	26107	14 x M10	61	3
2 11/16	2,6875	4,331	0,945	1,102	1,496	4027	35974	37710	23207	4565	26107	14 x M10	61	3
2 3/4	2,7500	4,337	0,945	1,102	1,496	4115	35974	36985	23207	4668	26107	14 x M10	61	3
2 7/8	2,8750	4,528	0,945	1,102	1,496	4285	35793	34810	22481	4882	25382	14 x M10	61	3
2 15/16	2,9375	4,528	0,945	1,102	1,496	4373	35793	34084	22481	4985	25382	14 x M10	61	3
3	3,0000	4,724	0,945	1,102	1,496	4447	35611	33359	21031	5096	23932	14 x M10	61	3
3 1/8	3,1250	4,724	0,945	1,102	1,496	4631	35611	31909	21031	5303	23932	14 x M10	61	3
3 1/4	3,2500	4,921	0,945	1,102	1,496	5487	40543	34810	23207	6306	26832	16 x M10	61	3
3 3/8	3,3750	4,921	0,945	1,102	1,496	5701	40543	34084	23207	6549	26832	16 x M10	61	3
3 7/16	3,4375	5,118	0,945	1,102	1,496	5782	40388	32634	22481	6667	25382	16 x M10	61	3
3 1/2	3,5000	5,118	0,945	1,102	1,496	5885	40388	32634	22481	6792	25382	16 x M10	61	3
3 5/8	3,6250	5,315	0,945	1,102	1,496	6785	45262	34810	23932	7914	27558	18 x M10	61	4
3 3/4	3,7500	5,305	0,945	1,102	1,496	7006	45262	34084	23932	8186	27558	18 x M10	61	4
3 7/8	3,8750	5,709	1,024	1,299	1,772	8186	50992	34084	23207	9580	26832	14 x M12	107	5
3 15/16	3,9375	5,709	1,024	1,299	1,772	8334	50992	33359	23207	9735	26832	14 x M12	107	5
4	4,0000	5,843	1,024	1,299	1,772	8481	50992	33359	22481	9890	26107	14 x M12	107	5
4 1/8	4,1250	6,102	1,024	1,299	1,772	8703	50860	31909	21756	10200	25382	14 x M12	107	6
4 3/16	4,1875	6,102	1,024	1,299	1,772	8850	50860	31184	21756	10355	25382	14 x M12	107	6
4 1/4	4,2500	6,102	1,024	1,299	1,772	8998	50860	31184	21756	10510	25382	14 x M12	107	6
4 7/16	4,4375	6,496	1,024	1,299	1,772	10694	57900	34084	23207	12538	26832	16 x M12	107	6
4 1/2	4,5000	6,496	1,024	1,299	1,772	10842	57900	33359	23207	12715	26832	16 x M12	107	6
4 3/4	4,7500	6,496	1,024	1,299	1,772	11432	57900	31909	23207	13423	26832	16 x M12	107	6
4 15/16	4,9375	7,087	1,339	1,496	1,969	14751	71998	29008	20306	17443	23932	20 x M12	107	8
5	5,0000	7,087	1,339	1,496	1,969	14972	71998	28283	20306	17664	23932	20 x M12	107	8
5 7/16	5,4375	7,480	1,339	1,496	1,969	17849	78887	29008	21031	21131	24657	22 x M12	107	9
5 1/2	5,5000	7,492	1,339	1,496	1,969	18070	78887	28283	21031	21374	24657	22 x M12	107	9
5 3/4	5,7500	7,874	1,339	1,496	1,969	20504	85719	29733	21756	24383	25382	24 x M12	107	9
6	6,0000	8,268	1,339	1,496	1,969	23085	92495	30458	22481	27562	26107	26 x M12	107	9
6 7/16	6,4375	8,858	1,496	1,732	2,283	28691	107102	29733	21756	34333	25382	22 x M14	170	13
6 1/2	6,5000	8,858	1,496	1,732	2,283	28986	107102	29008	21756	34665	25382	22 x M14	170	13
6 15/16	6,9375	9,252	1,496	1,732	2,283	33632	116373	29733	22481	40366	26832	24 x M14	170	13
7	7,0000	9,252	1,496	1,732	2,283	33927	116373	29733	22481	40728	26832	24 x M14	170	13
7 1/2	7,5000	9,823	1,811	2,047	2,598	42262	135407	26107	20306	50906	24657	28 x M14	170	19
7 7/8	7,875	10,236	1,811	2,047	2,598	47351	144497	26832	21031	57271	24657	30 x M14	170	19
8	8	10,504	1,811	2,047	2,598	48162	144497	26107	20306	58186	24657	30 x M14	170	19

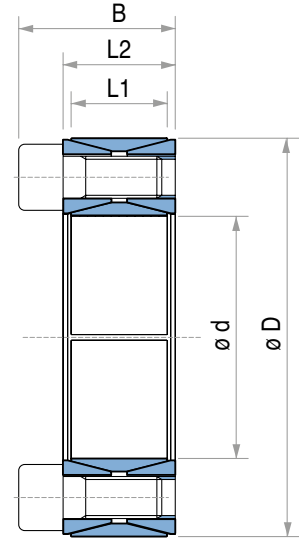

For larger diameter please contact our application engineering department.

TLK 250

TLK 250 L

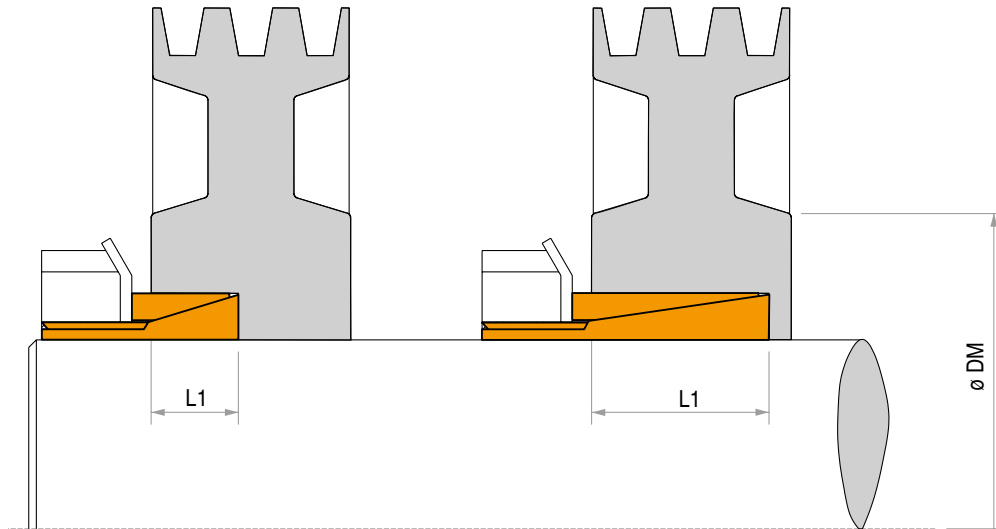

Characteristics

- Medium-low torque
- Small hub diameter
- Quick installation time
- Application economically advantageous

Installation

Carefully clean the hub and shaft contact surfaces and apply a light oil film. Slide the locking assembly into the hub bore, insert the shaft and tighten the nut at tightening torque M_s as indicated in the table and fold down the security washer tooth if fitted. The values M_t and F_{ax} indicated in the table are valid only in case of oil installation.

Do not use any oil with **molybdenum bisulphide** or high pressure additives and not grease. Above substances notably reduce the friction coefficient.

Dismantling

Loosen the tightening collar. As the cone angle of TLK 250 is about 17° , the unit is self releasing.

Tolerances, surface finish

A good surface finish by the machine tool is sufficient.
Maximum allowable surface finish:
Rt max $16 \mu m$ (Ra $3 \mu m$ - Rz $13 \mu m$)

Maximum permissible tolerances:
h8 for shaft
H8 for hub

For exact tolerance values see page 57.

Axial movement

TLK 250 and TLK 250L: during tightening of mounting nut the hub has a slight axial movement with respect to the shaft.

DM hub calculation

The pressure P_h in the hub can be compared to the inside pressure on a thick hollow cylinder.

For DM calculation see page 54.

TLK 250 DIMENSIONS

Dimensions						Torque	Axial force	Surface pressures on		Tightening screws		Weight
d x D	d	D	B	L1	D1			Shaft	Hub	DIN912 12.9	Tightening torque	
d x D	d	D	B	L1	D1	M _t Lb-ft	F _{ax} Lbf	P _s psi	P _h psi	Type	M _t Lb-ft	Lb
14 x 25	0,551	0,984	0,650	0,256	1,260	28	1124	29008	15954	KM4	70	0,1
15 x 25	0,591	0,984	0,650	0,256	1,260	30	1124	26832	15954	KM4	70	0,1
16 x 25	0,630	0,984	0,650	0,256	1,260	32	1124	25237	15954	KM4	70	0,1
17 x 30	0,669	1,181	0,709	0,256	1,496	41	1349	28572	16244	KM5	118	0,2
18 x 30	0,709	1,181	0,709	0,256	1,496	43	1349	26977	16244	KM5	118	0,2
19 x 30	0,748	1,181	0,709	0,256	1,496	46	1574	25527	16244	KM5	118	0,2
20 x 30	0,787	1,181	0,709	0,256	1,496	49	1574	24221	16099	KM5	118	0,2
22 x 35	0,866	1,378	0,709	0,256	1,772	71	1798	29298	18420	KM6	162	0,2
24 x 35	0,945	1,378	0,709	0,256	1,772	77	2023	26832	18420	KM6	162	0,2
25 x 35	0,984	1,378	0,709	0,256	1,772	81	2023	25817	18420	KM6	162	0,2
28 x 40	1,102	1,575	0,768	0,276	2,047	111	2248	25527	17840	KM7	251	0,2
30 x 40	1,181	1,575	0,768	0,276	2,047	118	2473	23786	17840	KM7	251	0,2
32 x 45	1,260	1,772	0,846	0,315	2,283	155	2698	24221	17405	KM8	354	0,4
35 x 45	1,378	1,772	0,846	0,315	2,283	170	2923	22191	17405	KM8	354	0,4
36 x 45	1,417	1,772	0,846	0,315	2,283	177	2923	21611	17405	KM8	354	0,3
38 x 52	1,496	2,047	0,965	0,394	2,559	214	3147	18275	13489	KM9	502	0,6
40 x 52	1,575	2,047	0,965	0,394	2,559	229	3372	17405	13489	KM9	502	0,5
42 x 57	1,654	2,244	1,004	0,394	2,756	273	3822	19000	13924	KM10	642	0,7
45 x 57	1,772	2,244	1,004	0,394	2,756	295	4047	17695	13924	KM10	642	0,6
48 x 62	1,890	2,441	1,004	0,394	2,953	369	4721	19580	15229	KM11	715	0,7
50 x 62	1,969	2,441	1,004	0,394	2,953	384	4721	18855	15229	KM11	715	0,7
55 x 68	2,165	2,677	1,083	0,472	3,150	450	4946	14939	12183	KM12	811	0,8
56 x 68	2,205	2,677	1,083	0,472	3,150	457	4946	14649	11893	KM12	811	0,7
60 x 73	2,362	2,874	1,121	0,472	3,346	590	6070	16389	13489	KM13	959	0,9
63 x 79	2,480	3,110	1,201	0,551	3,622	723	6969	15519	12473	KM14	1180	1,2
65 x 79	2,559	3,110	1,201	0,551	3,622	745	6969	15084	12473	KM14	1180	1,1
70 x 84	2,756	3,307	1,240	0,551	3,858	915	7868	15954	13343	KM15	2000	0,60

* Without washer

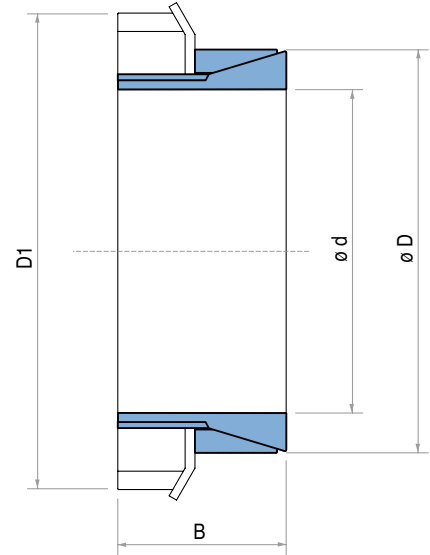

TLK 250L DIMENSIONS

Dimensions						Torque	Axial force	Surface pressures on		Tightening screws		Weight
d x D	d	D	B	L1	D1			Shaft	Hub	DIN912 12.9	Tightening torque	
d x D	d	D	B	L1	D1	M _t Lb-ft	F _{ax} Lbf	P _s psi	P _h psi	Type	M _t Lb-ft	Lb
14 x 25	0,551	0,984	1,181	0,787	1,260	47	2023	12328	6527	KM4	70	0,2
15 x 25	0,591	0,984	1,181	0,787	1,260	52	2023	11603	6527	KM4	70	0,2
16 x 25	0,630	0,984	1,181	0,787	1,260	54	2023	10878	6527	KM4	70	0,2
17 x 25	0,669	0,984	1,260	0,787	1,260	59	2023	10153	6527	KM4*	70	0,2
18 x 30	0,709	1,181	1,260	0,787	1,496	74	2248	11603	6527	KM5	118	0,3
19 x 30	0,748	1,181	1,260	0,787	1,496	77	2473	10878	6527	KM5	118	0,3
20 x 30	0,787	1,181	1,260	0,787	1,496	83	2473	10153	6527	KM5	118	0,2
22 x 35	0,866	1,378	1,417	0,984	1,772	120	3147	10153	6527	KM6	162	0,4
24 x 35	0,945	1,378	1,417	0,984	1,772	131	3147	9427	6527	KM6	162	0,4
25 x 35	0,984	1,378	1,417	0,984	1,772	136	3147	8702	6527	KM6	162	0,3
28 x 40	1,102	1,575	1,654	1,181	2,047	184	3822	7977	5802	KM7	251	0,5
30 x 40	1,181	1,575	1,654	1,181	2,047	199	3822	7252	5802	KM7	251	0,5
32 x 45	1,260	1,772	1,732	1,181	2,283	258	4721	8702	6527	KM8	354	0,7
35 x 45	1,378	1,772	1,732	1,181	2,283	288	4721	7977	6527	KM8	354	0,6
38 x 50	1,496	1,969	1,772	1,181	2,559	369	5845	8702	6527	KM9	502	0,8
40 x 50	1,575	1,969	1,772	1,181	2,559	384	5845	7977	6527	KM9	502	0,7
42 x 55	1,654	2,165	1,811	1,181	2,756	465	6744	9427	7252	KM10	642	0,9
45 x 55	1,772	2,165	1,811	1,181	2,756	502	6744	8702	7252	KM10	642	0,9
48 x 60	1,890	2,362	1,811	1,181	2,953	620	7868	8702	7252	KM11	715	1,0
50 x 60	1,969	2,362	1,811	1,181	2,953	649	7868	8702	7252	KM11	715	0,9
55 x 65	2,165	2,559	1,811	1,181	3,150	760	8318	8702	7252	KM12	811	1,0
60 x 70	2,362	2,756	2,047	1,181	3,346	1003	10116	9427	7977	KM13	959	1,2

* Without washer

Locking assembly self-centering

TLK 250 L

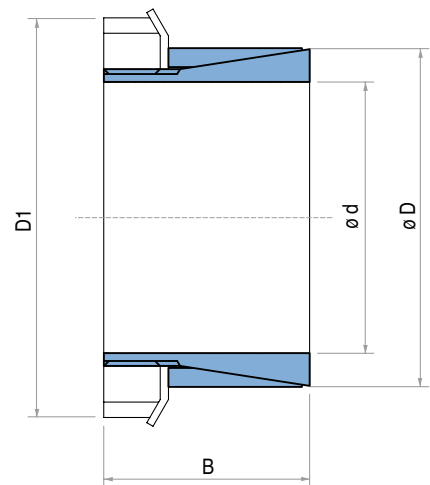

TLK 300

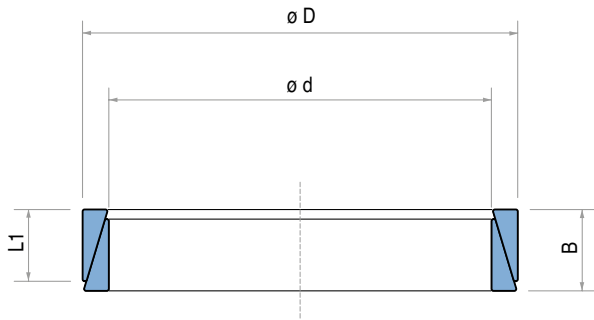
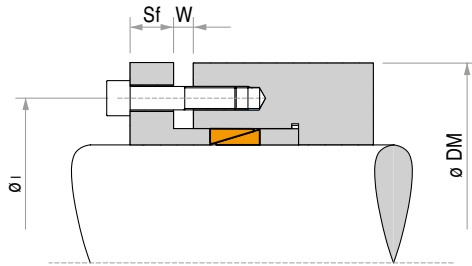

TLK 300 DIMENSIONS

dg	DIN912			C=0,140		
	Pv in N			Mt in Nm		
M4	877	1225	1473	2	3	4
M5	1428	2012	2405	4	6	7
M6	2023	2833	3395	7	10	13
[M7]	2967	4159	4991	12	17	21
M8	3709	5216	6272	18	26	30
[M9]	4946	6947	8340	27	38	45
M10	5890	8295	9959	36	51	61
M12	8610	12140	14500	63	89	107
M14	11803	16636	19896	100	140	170
M16	16411	22931	27652	155	218	262
M18	19783	27876	33272	214	299	358
M20	25628	35970	43164	302	428	509
M22	31698	44737	53730	406	575	686
M24	36869	51706	62048	524	738	885
M27	48334	67893	81606	774	1106	1328
M30	58900	82730	99366	1069	1475	1770

$$Pa = N^{\circ} \text{ of screws} \cdot Pv$$

$$Pt = \text{see page 27}$$

$$M_t \text{ transmissible} = \frac{Pa - Pt}{0,54} \cdot 0,12 \cdot \frac{d}{2000}$$

Screws center distance $l = D + 12 + dg$ (screws fixed on the hub) Flange thickness $Sf = dg \cdot 1,3$ (screws quality 8.8)
 Screws center distance $l = d - 12 - dg$ (screws fixed on the shaft) Flange thickness $Sf = dg \cdot 1,8$ (screws quality 12.9)

Note: On request the type TLK 300 can be supplied also with split rings. This will increase the transmissible torque M_t . Please contact our application engineering department for additional information.

Units: Pa & Pt in Lbf M_t in Lb-ft d, D, i & sf in inch dg in mm

Characteristics

- Medium low torque
- Compact space
- Quick installation time
- Application economically advantageous

Installation

Carefully clean the hub and shaft contact surfaces and apply a light oil film. Slide the locking elements into the hub bore, insert the shaft and tighten gradually and regularly in crossed sequence all screws to reach the tightening torque M_s as indicated in the table. The values M_t and F_{ax} indicated in the table are valid only in case of oil installation.

Do not use any oil with **molybdenum bisulphide** or high pressure additives and not grease. Above substances notably reduce the friction coefficient.

Dismantling

By loosening all tightening screws the locking elements are released and the clamping is free. However in case of difficulties slightly hammer the hub.

Tolerances, surface finish

A good surface finish by the machine tool is sufficient.
 Maximum allowable surface finish:
 Rt max 6 μm (Ra 1 μm - Rz 5 μm)

Maximum permissible tolerances:
 shaft h6 - hub H7 (up to 40mm d. diameter)
 shaft h8 - hub H8 (over 42mm d. diameter)

For exact tolerance values see page 57.

M_t transmissible

- Nr. 1 TLK 300 $M_t = M_t \text{ cat.}$
- Nr. 2 TLK 300 $M_t = M_t \text{ cat.} \cdot 1,55$
- Nr. 3 TLK 300 $M_t = M_t \text{ cat.} \cdot 1,85$
- Nr. 4 TLK 300 $M_t = M_t \text{ cat.} \cdot 2,02$

DM hub calculation

The pressure P_h in the hub can be compared to the inside pressure on a thick hollow cylinder.

For DM calculation see page 54.

TLK 350

TLK 350 DIMENSIONS

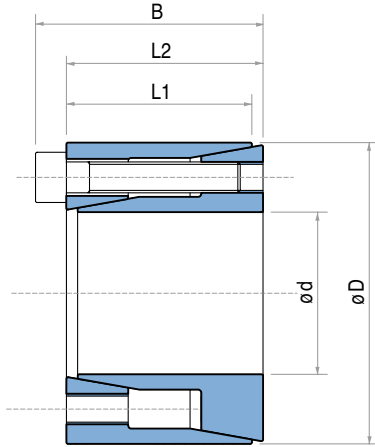

Dimensions						Torque	Axial force	Surface pressures on		Tightening screws		Weight
d	d	D	L1	L2	B			Shaft	Hub	DIN912 12.9	Tightening torque	
mm	inch	inch	inch	inch	inch	M _t Lb-ft	F _{ax} Lbf	p _s psi	p _h psi	N° x Type	M _t Lb-ft	Lb
1/4	0,2500	0,630	0,413	0,433	0,531	7	685	25157	9984	3 x M2,5	1	0,1
5/16	0,3125	0,709	0,413	0,433	0,531	9	685	20126	8875	3 x M2,5	1	0,1
3/8	0,3750	0,787	0,492	0,512	0,610	14	913	18922	9011	4 x M2,5	1	0,1
7/16	0,4375	0,866	0,492	0,512	0,610	17	913	16218	8192	4 x M2,5	1	0,1
1/2	0,5000	1,024	0,650	0,669	0,787	28	1333	15854	7744	4 x M3	2	0,1
5/8	0,6250	1,260	0,650	0,669	0,827	61	2335	22213	11020	4 x M4	4	0,2
3/4	0,7500	1,378	0,807	0,827	0,984	73	2335	14985	8156	4 x M4	4	0,2
7/8	0,8750	1,575	0,807	0,827	1,024	138	3815	20982	11658	4 x M5	7	0,3
15/16	0,9375	1,850	0,984	1,024	1,260	208	5383	22321	11309	4 x M6	13	0,5
1	1,0000	1,850	0,984	1,024	1,260	222	5383	20926	11309	4 x M6	13	0,5
1 1/8	1,1250	1,969	0,984	1,024	1,260	376	8075	27902	15946	6 x M6	13	0,5
1 3/16	1,1875	2,165	0,984	1,024	1,260	396	8075	26433	14496	6 x M6	13	1
1 1/4	1,2500	2,165	0,984	1,024	1,260	417	8075	25112	14496	6 x M6	13	1
1 3/8	1,3750	2,362	1,181	1,220	1,457	611	10767	25529	14860	6 x M6	13	1
1 7/16	1,4375	2,559	1,181	1,220	1,457	639	10767	24419	13717	8 x M6	13	1
1 1/2	1,5000	2,559	1,181	1,220	1,457	667	10767	23402	13717	8 x M6	13	1
1 5/8	1,6250	2,953	1,378	1,417	1,732	1000	14920	25777	14186	6 x M8	30	2
1 11/16	1,6875	2,953	1,378	1,417	1,732	1039	14920	24822	14186	6 x M8	30	2
1 3/4	1,7500	2,953	1,378	1,417	1,732	1078	14920	23936	14186	6 x M8	30	2
1 7/8	1,8750	3,150	1,378	1,417	1,732	1539	19894	29787	17732	8 x M8	30	2
1 15/16	1,9375	3,150	1,378	1,417	1,732	1590	19894	28826	17732	8 x M8	30	2

Characteristics

- Medium-high torque
- Easy mounting
- Quick installation time
- Few clamping screws
- Small dimensions
- For other information, see TLK 132.

Dimensions						Torque	Axial force	Surface pressures on		Tightening screws		Weight
d x D	d	D	L1	L2	B			Shaft	Hub	DIN912 12.9	Tightening torque	
mm	inch	inch	inch	inch	inch	M _t Lb-ft	F _{ax} Lbf	p _s psi	p _h psi	N° x Type	M _t Lb-ft	Lb
6 x 16	0,236	0,630	0,413	0,433	0,531	7	674	26687	10008	3 x M2,5	0,9	0,03
6,4 x 16	0,250	0,630	0,413	0,433	0,531	7	674	25092	10008	3 x M2,5	1,2	0,03
7 x 17	0,276	0,669	0,413	0,433	0,531	8	674	22771	9427	3 x M2,5	1,2	0,03
8 x 18	0,315	0,709	0,413	0,433	0,531	9	674	20015	8847	3 x M2,5	1,2	0,03
9 x 20	0,354	0,787	0,492	0,512	0,610	13	899	20015	8992	4 x M2,5	1,2	0,04
9,5 x 20	0,375	0,787	0,492	0,512	0,610	14	899	18855	8992	4 x M2,5	1,2	0,04
10 x 20	0,394	0,787	0,492	0,512	0,610	15	899	17985	8992	4 x M2,5	1,2	0,04
11 x 22	0,433	0,866	0,492	0,512	0,610	16	899	16389	8122	4 x M2,5	1,2	0,05
12 x 22	0,472	0,866	0,492	0,512	0,610	18	899	15084	8122	4 x M2,5	1,2	0,05
14 x 26	0,551	1,024	0,650	0,669	0,787	31	1349	14359	7687	4 x M3	2,1	0,09
15 x 28	0,591	1,102	0,650	0,669	0,787	32	1349	13489	7252	4 x M3	2,1	0,10
16 x 32	0,630	1,260	0,650	0,669	0,827	61	2338	22046	11023	4 x M4	4,9	0,15
17 x 35	0,669	1,378	0,807	0,827	0,984	65	2338	16824	8122	4 x M4	4,9	0,20
18 x 35	0,709	1,378	0,807	0,827	0,984	69	2338	15809	8122	4 x M4	4,9	0,19
19 x 35	0,748	1,378	0,807	0,827	0,984	73	2338	15084	8122	4 x M4	4,9	0,18
20 x 38	0,787	1,496	0,807	0,827	1,024	125	3822	23351	12328	4 x M5	10	0,22
22 x 40	0,866	1,575	0,807	0,827	1,024	138	3822	21176	11603	4 x M5	10	0,24
24 x 47	0,945	1,850	0,984	1,024	1,260	212	5395	22191	11313	4 x M6	17	0,44
25 x 47	0,984	1,850	0,984	1,024	1,260	221	5395	21321	11313	4 x M6	17	0,42
25 x 47	1,000	1,850	0,984	1,024	1,260	224	5395	20885	11313	4 x M6	17	0,40
28 x 50	1,102	1,969	0,984	1,024	1,260	371	8093	28427	15954	6 x M6	17	0,49
30 x 55	1,181	2,165	0,984	1,024	1,260	398	8093	26542	14504	6 x M6	17	0,60
32 x 55	1,260	2,165	0,984	1,024	1,260	424	8093	24946	14504	6 x M6	17	0,55
35 x 60	1,378	2,362	1,181	1,220	1,457	618	10791	25527	14794	8 x M6	17	0,79
38 x 65	1,496	2,559	1,181	1,220	1,457	671	10791	23496	13779	8 x M6	17	0,95
40 x 65	1,575	2,559	1,181	1,220	1,457	707	10791	22336	13779	8 x M6	17	0,88
42 x 75	1,654	2,953	1,378	1,417	1,732	1028	14905	25382	14214	6 x M8	41	1,48
45 x 75	1,772	2,953	1,378	1,417	1,732	1101	14905	23641	14214	6 x M8	41	1,39
48 x 80	1,890	3,150	1,378	1,417	1,732	1567	19896	29588	17695	8 x M8	41	1,63
50 x 80	1,969	3,150	1,378	1,417	1,732	1631	19896	28427	17695	8 x M8	41	1,54

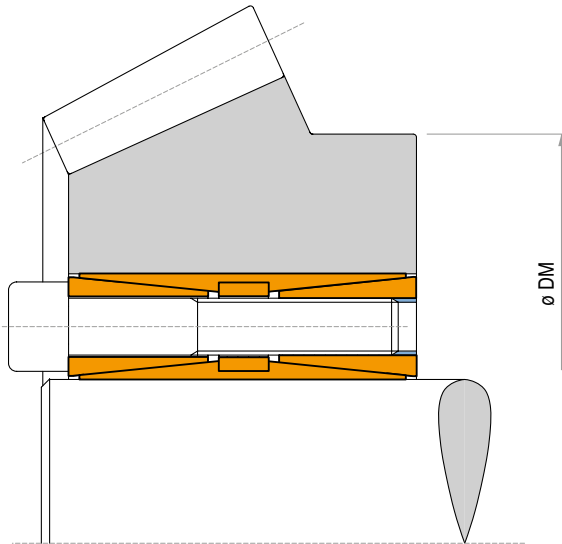

Characteristics

- Very high torques
- Capacity to withstand bending moments
- Even pressures distribution
- No shaft-hub axial movement
- Excellent for Drum pulleys, motorized pulleys

Installation

Carefully clean the hub and shaft contact surfaces and apply a light oil film. Slide the locking assembly into the hub bore and insert the shaft. Tighten gradually and regularly in crossed sequence all screws up to 50% of the M_s value indicated in the table. Repeat the same operation by tightening all screws at the M_s torque indicated in the table.

Starting from the last tightened screw, check, in continuous sequence, that all the screws are tightened at the tightening torque M_s indicated. Repeat this procedure maximum twice. After this control any further operation is needed.

Do not use any oil with molybdenum bisulphide or high pressure additives and not grease. Above substances notably reduce the friction coefficient. For additional information on installation refer to page 58.

Dismantling

Loosen the clamping screws. Insert the screws into the dismantling threads of the front cone and tighten them gradually in crossed sequence up to 50% of the M_s value indicated in the table. Repeat the same operation by tightening the screws at the tightening torque M_s indicated in the table. When the front cone is loose, to release the rear cone, insert the screws in the middle ring, and repeat the same operation of the upper ring. For additional information on dismantling refer to page 58.

Tolerances, surface finish

A good surface finish by the machine tool is sufficient.
Maximum allowable surface finish:
Rt max 16 μm (Ra 3 μm - Rz 13 μm)

Maximum permissible tolerances:

h8 for shaft
H8 for hub

For exact tolerance values see page 57.

Axial movement

During tightening of mounting screws the hub has no axial movement with respect to the shaft.

DM hub calculation

For DM calculation see page 54.

ATTENTION: In case of reuse of the TLK 400 or TLK 401 check that the position of the dismantling threads of the front cone and middle ring are like in new pieces.

TLK 400

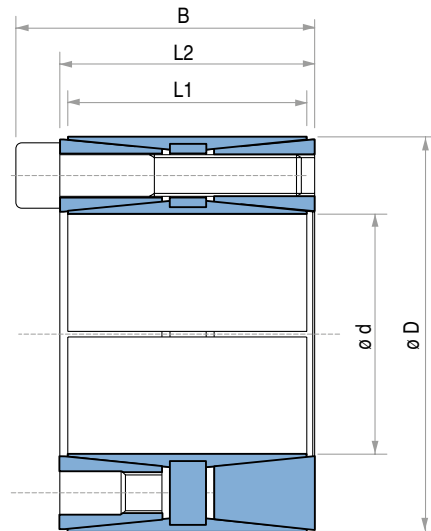

TLK 400 DIMENSIONS

Dimensions						Tightening screws		Torque	Axial force	Surface pressures on		Weight
						DIN912 12.9	Tightening torque			Shaft	Hub	
d x D mm	d inch	D inch	L1 inch	L2 inch	B inch	N° x Type	M _s Lb-ft	M _t Lb-ft	F _{ax} Lbf	P _s psi	P _h psi	Lb
45 x 75	1,772	2,953	2,205	2,520	2,835	8 x M8	30	2552	34845	23931	14504	2,9
48 x 80	1,890	3,150	2,205	2,520	2,835	8 x M8	30	2714	34845	21756	13779	3,3
50 x 80	1,969	3,150	2,205	2,520	2,835	8 x M8	30	2817	34845	21321	13779	3,1
55 x 85	2,165	3,346	2,205	2,520	2,835	8 x M8	30	3142	34845	19580	12328	3,3
60 x 90	2,362	3,543	2,205	2,520	2,835	10 x M8	30	4293	42714	22481	14504	3,3
65 x 95	2,559	3,740	2,205	2,520	2,835	10 x M8	30	4625	42714	20305	13779	3,5
70 x 110	2,756	4,331	2,756	3,071	3,465	10 x M10	61	7914	68567	24656	15229	6,6
75 x 115	2,953	4,528	2,756	3,071	3,465	10 x M10	61	8511	68567	22481	14504	6,8
80 x 120	3,150	4,724	2,756	3,071	3,465	12 x M10	61	10842	82955	25382	16679	7,7
85 x 125	3,346	4,921	2,756	3,071	3,465	12 x M10	61	11580	82955	23931	15954	7,7
90 x 130	3,543	5,118	2,756	3,071	3,465	12 x M10	61	12251	83179	22771	15374	8,4
95 x 135	3,740	5,315	2,756	3,071	3,465	12 x M10	61	12929	83179	21756	14794	8,8
100 x 145	3,937	5,709	3,543	3,937	4,409	12 x M12	107	19840	120947	23206	15954	13,2
110 x 155	4,331	6,102	3,543	3,937	4,409	12 x M12	107	21780	120947	20740	14794	13,7
120 x 165	4,724	6,496	3,543	3,937	4,409	14 x M12	107	27740	141180	22336	16244	15,0
130 x 180	5,118	7,087	4,094	4,567	5,118	12 x M14	170	35403	165909	20740	15374	21,6
140 x 190	5,512	7,480	4,094	4,567	5,118	14 x M14	170	44468	193561	23206	16969	22,5
150 x 200	5,906	7,874	4,094	4,567	5,118	16 x M14	170	54432	221437	23931	18130	24,0
160 x 210	6,299	8,268	4,094	4,567	5,118	16 x M14	170	58098	220987	22481	17114	25,4
170 x 225	6,693	8,858	5,276	5,748	6,378	14 x M16	262	75032	269096	20305	15664	37,9
180 x 235	7,087	9,252	5,276	5,748	6,378	16 x M16	262	90868	307763	21756	16679	39,7
190 x 250	7,480	9,843	5,276	5,748	6,378	16 x M16	262	95795	307539	20450	15954	47,4
200 x 260	7,874	10,236	5,276	5,748	6,378	16 x M16	262	100928	307539	19870	15084	48,5
220 x 285	8,661	11,220	5,276	5,748	6,378	20 x M16	262	138662	384423	22481	17405	55,1
240 x 305	9,449	12,008	5,276	5,748	6,378	22 x M16	262	165951	422641	22481	17405	59,5
260 x 325	10,236	12,795	5,276	5,748	6,378	22 x M16	262	179965	422641	22481	16679	66,1
280 x 355	11,024	13,976	6,496	6,969	7,756	20 x M20	509	275111	600240	21030	17405	101,4
300 x 375	11,811	14,764	6,496	6,969	7,756	22 x M20	509	324527	658690	22481	18130	110,2
320 x 405	12,598	15,945	6,496	6,969	7,756	22 x M20	509	346654	658690	21030	16679	132,3
340 x 425	13,386	16,732	6,496	6,969	7,756	24 x M20	509	401234	719389	21756	17405	143,3
360 x 455	14,173	17,913	7,480	7,953	8,819	22 x M22	686	485316	820553	20305	15954	196,2
380 x 475	14,961	18,701	7,480	7,953	8,819	26 x M22	686	605539	971175	23206	18855	205,0
400 x 495	15,748	19,488	7,480	7,953	8,819	26 x M22	686	637254	971175	21756	17405	216,1

For larger diameter please contact our application engineering department. NOTE: it is possible to reduce the screws tightening torque down to 60% of the values indicated in the above table; as a result the M_t, F_{ax}, P_s, P_h are reduced proportionally.

TLK 401 TLK 401.0

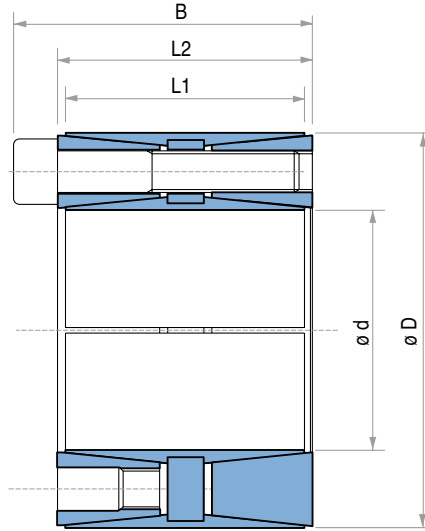

TLK 401 / TLK 401.0 DIMENSIONS

Dimensions						Screws DIN912 12.9	Tightening torque	Torque	Axial force	Surface pressures on		Tightening torque	Torque	Axial force	Surface pressures on		Weight
										Shaft	Hub				Shaft	Hub	
d x D mm	d inch	D inch	L1 inch	L2 inch	B inch	N° x Type	M _t Lb-ft	M _t Lb-ft	F _{ax} Lbf	P _s psi	P _h psi	M _t Lb-ft	M _t Lb-ft	F _{ax} Lbf	P _s psi	P _h psi	Lb
70 x 110	2,756	4,331	1,969	2,283	2,677165354	8 x M10	36	3762	32597	16244	10298	61	6358	55078	27557	17405	5,1
75 x 115	2,953	4,528	1,969	2,283	2,677165354	8 x M10	36	3998	32597	14939	9863	61	6756	55078	25237	16679	5,3
80 x 120	3,150	4,724	1,969	2,283	2,677165354	8 x M10	36	4293	32597	14069	9427	61	7258	55078	23786	15954	5,5
85 x 125	3,346	4,921	1,969	2,283	2,677165354	10 x M10	36	5679	40915	16534	11168	61	9588	69016	27992	18855	5,7
90 x 130	3,543	5,118	1,969	2,283	2,677165354	10 x M10	36	5974	40915	15519	10733	61	10105	69016	26252	18130	6,0
95 x 135	3,740	5,315	1,969	2,283	2,677165354	10 x M10	36	6343	40915	14794	10443	61	10724	69016	25092	17695	6,2
100 x 145	3,937	5,709	2,362	2,756	3,149606299	10 x M10	36	6712	40915	11603	7977	61	11344	69016	19580	13489	8,8
110 x 155	4,331	6,102	2,362	2,756	3,149606299	10 x M10	36	7376	40915	10878	7542	61	12465	69016	18420	12763	9,9
120 x 165	4,724	6,496	2,362	2,756	3,149606299	12 x M10	36	9662	49008	11603	8557	61	16337	82055	19580	14504	10,6
130 x 180	5,118	7,087	2,677	3,150	3,622047244	12 x M12	63	15268	71714	13779	10008	107	25711	120722	23206	16824	13,9
140 x 190	5,512	7,480	2,677	3,150	3,622047244	12 x M12	63	16448	71714	12908	9572	107	27695	120722	21756	16099	14,6
150 x 200	5,906	7,874	2,677	3,150	3,622047244	12 x M12	63	17628	71714	12038	8992	107	29687	120722	20305	15229	15,4
160 x 210	6,299	8,268	2,677	3,150	3,622047244	14 x M12	63	21979	83629	13053	10008	107	37011	140730	22046	16824	16,3
170 x 225	6,693	8,858	2,953	3,425	3,897637795	16 x M12	63	26700	95769	12908	9718	107	44962	161188	21756	16389	22,0
180 x 235	7,087	9,252	2,953	3,425	3,897637795	16 x M12	63	28249	95769	12183	9282	107	47573	161188	20595	15664	24,9
190 x 250	7,480	9,843	3,465	3,937	4,409448819	18 x M12	63	33559	107683	11023	8412	107	56512	181196	18565	14214	30,9
200 x 260	7,874	10,236	3,465	3,937	4,409448819	18 x M12	63	35329	107683	10443	8122	107	59492	181196	17695	13779	33,5
220 x 285	8,661	11,220	3,858	4,331	4,881889764	14 x M14	100	41451	114877	9137	7107	170	69869	193561	15519	12038	43,0
240 x 305	9,449	12,008	3,858	4,331	4,881889764	18 x M14	100	58120	147699	10733	8412	170	97970	247290	18130	14214	47,4
260 x 325	10,236	12,795	3,858	4,331	4,881889764	20 x M14	100	69995	164111	11023	8847	170	117988	276515	18565	14939	50,7
280 x 355	11,024	13,976	4,724	5,197	5,826771654	20 x M16	155	104734	228181	11603	9137	262	176469	384423	19580	15374	63,9
300 x 375	11,811	14,764	4,724	5,197	5,826771654	24 x M16	155	134236	273817	12908	10443	262	226173	460858	21756	17550	67,2
320 x 405	12,598	15,945	5,315	5,787	6,417322835	24 x M16	155	143087	273817	10878	8702	262	241087	460858	18420	14649	103,6
340 x 425	13,386	16,732	5,315	5,787	6,417322835	24 x M16	155	152675	273817	10298	8267	262	257247	460858	17405	13924	110,2

For larger diameter please contact our application engineering department.

TLK 450

TLK 451 TLK 452

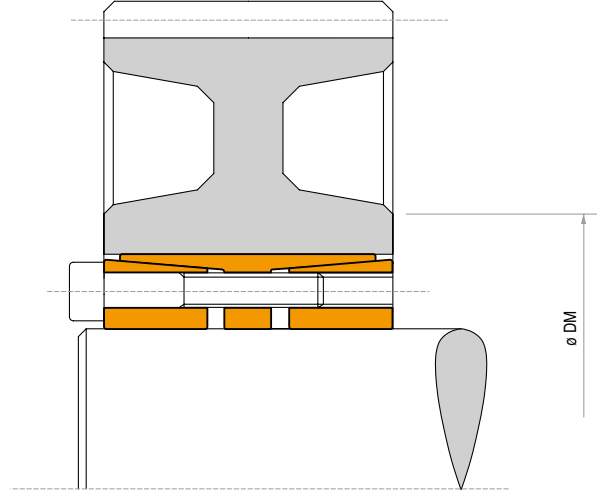
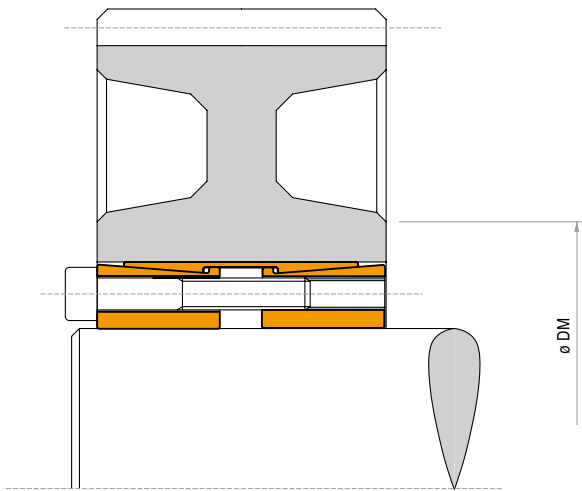

Characteristics

- Very high torques
- Capacity to withstand bending moments
- Compact size
- Excellent for bulk handling applications, drum pulleys

Installation

Carefully clean the hub and shaft contact surfaces and apply a light oil film. Slide the locking assembly into the hub bore and insert the shaft. Tighten gradually and regularly in crossed sequence all screws up to 50% of the M_s value indicated in the table. Repeat the same operation by tightening all screws at the M_s torque indicated in the table.

Starting from the last tightened screw, check, in continuous sequence, that all the screws are tightened at the tightening torque M_s indicated. Repeat this procedure maximum twice.

Do not use any oil with **molybdenum bisulphide** or high pressure additives and not grease. Above substances notably reduce the friction coefficient.

Dismantling

Loosen the clamping screws. Insert the screws into the dismantling threads of the front cone and tighten them gradually in crossed sequence up to 50% of the M_s value indicated in the table. Repeat the same operation by tightening the screws at the tightening torque M_s indicated in the table.

When the front cone is loose, to release the rear cone:

TLK 450: keep tightening the screws and repeat the sequence above.

TLK 451/452: insert the screws in the middle flange and repeat the same operation of the upper ring.

For additional information on dismantling refer to page 58.

Tolerances, surface finish

A good surface finish by the machine tool is sufficient.

Maximum allowable surface finish:

Rt max 16 μm (Ra 3 μm - Rz 13 μm)

Maximum permissible tolerances:

h8 for shaft

H8 for hub

For exact tolerance values see page 57.

DM hub calculation

For DM calculation see page 54.

ATTENTION: In case of reusing TLK451 check that the position of all dismantling threads of the front cone are positioned correctly. The dismantling threads have to be blind due to the middle flange construction.

Locking assembly - Self-centering

TLK 450

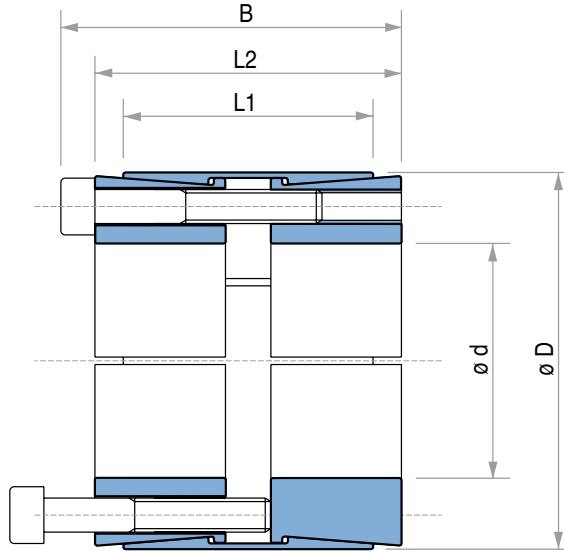

TLK 450 DIMENSIONS

Dimensions						Tightening screws		Torque	Axial force	Surface pressures on		Weight
						DIN912 12.9	Tightening torque			Shaft	Hub	
d x D mm	d inch	D inch	L1 inch	L2 inch	B inch	N° x Type	M _t Lb-ft	M _t Lb-ft	F _{ax} Lbf	P _s psi	P _n psi	Lb
25 x 50	0,984	1,969	1,535	1,772	2,008	8 x M6	13	701	17085	35534	17695	1,1
28 x 55	1,102	2,165	1,535	1,772	2,008	8 x M6	13	789	17085	31763	16099	1,3
30 x 55	1,181	2,165	1,535	1,772	2,008	8 x M6	13	848	17085	29588	16099	1,3
35 x 60	1,378	2,362	1,535	1,772	2,008	8 x M6	13	988	17085	25382	14794	1,5
38 x 65	1,496	2,559	1,535	1,772	2,008	8 x M6	13	1069	17085	23351	13634	1,5
40 x 65	1,575	2,559	1,535	1,772	2,008	8 x M6	13	1128	17085	22191	13634	1,5
42 x 75	1,654	2,953	2,205	2,520	2,835	8 x M8	30	2191	31698	27267	15229	2,2
45 x 75	1,772	2,953	2,205	2,520	2,835	8 x M8	30	2323	31698	25382	15229	2,0
48 x 80	1,890	3,150	2,205	2,520	2,835	8 x M8	30	2950	37318	23786	14214	3,1
50 x 80	1,969	3,150	2,205	2,520	2,835	8 x M8	30	3061	37318	22916	14214	2,9
55 x 85	2,165	3,346	2,205	2,520	2,835	8 x M8	30	3356	37318	20740	13489	3,3
60 x 90	2,362	3,543	2,205	2,520	2,835	10 x M8	30	4573	46535	23786	15809	3,5
65 x 95	2,559	3,740	2,205	2,520	2,835	10 x M8	30	4979	46535	22046	15084	4,0
70 x 110	2,756	4,331	2,756	3,071	3,465	10 x M10	61	8519	74187	25962	16534	6,6
75 x 115	2,953	4,528	2,756	3,071	3,465	10 x M10	61	9109	74187	24221	15809	7,3
80 x 120	3,150	4,724	2,756	3,071	3,465	12 x M10	61	11653	89024	27267	18130	7,7
85 x 125	3,346	4,921	2,756	3,071	3,465	12 x M10	61	12391	89024	25672	17405	8,2
90 x 130	3,543	5,118	2,756	3,071	3,465	12 x M10	61	13129	89024	24221	16679	8,4
95 x 135	3,740	5,315	2,756	3,071	3,465	12 x M10	61	13866	89024	22916	16099	11,0
100 x 145	3,937	5,709	3,543	3,937	4,409	12 x M12	107	21242	129490	24656	16969	13,2
110 x 155	4,331	6,102	3,543	3,937	4,409	12 x M12	107	23381	129490	22481	15954	13,7
120 x 165	4,724	6,496	3,543	3,937	4,409	14 x M12	107	29724	151296	23931	17405	15,9
130 x 180	5,118	7,087	4,094	4,567	5,118	12 x M14	170	37911	177824	22481	16244	22,0
140 x 190	5,512	7,480	4,094	4,567	5,118	14 x M14	170	47647	207499	24366	17985	22,5
150 x 200	5,906	7,874	4,094	4,567	5,118	16 x M14	170	58341	237173	25962	19580	23,8
160 x 210	6,299	8,268	4,094	4,567	5,118	16 x M14	170	62250	237173	24366	18565	25,4
170 x 225	6,693	8,858	5,276	5,748	6,378	14 x M16	262	80394	288430	21611	16389	37,5
180 x 235	7,087	9,252	5,276	5,748	6,378	16 x M16	262	97358	329570	23351	17985	40,8
190 x 250	7,480	9,843	5,276	5,748	6,378	16 x M16	262	102521	329570	22191	16824	47,4
200 x 260	7,874	10,236	5,276	5,748	6,378	16 x M16	262	108053	329570	21030	16244	48,5
220 x 285	8,661	11,220	5,276	5,748	6,378	20 x M16	262	148619	412075	23931	18420	55,1
240 x 305	9,449	12,008	5,276	5,748	6,378	22 x M16	262	178490	453440	24076	19000	59,5
260 x 325	10,236	12,795	5,276	5,748	6,378	22 x M16	262	193241	453440	22336	17840	66,1
280 x 355	11,024	13,976	6,496	6,969	7,756	20 x M20	509	295025	643403	23786	18855	101,4
300 x 375	11,811	14,764	6,496	6,969	7,756	22 x M20	509	348129	707699	24511	19580	110,2
320 x 405	12,598	15,945	6,496	6,969	7,756	22 x M20	509	371363	707699	22916	18130	132,3
340 x 425	13,386	16,732	6,496	6,969	7,756	24 x M20	509	430367	771994	23496	18855	143,3
360 x 455	14,173	17,913	7,480	7,953	8,819	22 x M22	686	519981	880801	22046	17405	196,2
380 x 475	14,961	18,701	7,480	7,953	8,819	26 x M22	686	649055	1041090	24656	19725	205,0
400 x 495	15,748	19,488	7,480	7,953	8,819	26 x M22	686	682983	1041090	23496	19000	216,1

For larger diameter or inch series please contact us.

NOTE: it is possible to reduce the screws tightening torque down to 60% of the values indicated in above table; as a result M_t, F_{ax}, P_w, P_n are reduced proportionally.

TLK 450 DIMENSIONS

Dimensions						Tightening screws		Torque	Axial force	Surface pressures on		Weight
						DIN912 12.9	Tightening torque			Shaft	Hub	
d inch	d inch	D inch	L1 inch	L2 inch	B inch	N° x Type	M _t Lb-ft	M _t Lb-ft	F _{ax} Lbf	P _s psi	P _n psi	Lb
1	1,0000	2,165	1,535	1,772	2,008	8 x M6	13	826	20239	34965	16147	1
1 3/16	1,1875	2,165	1,535	1,772	2,008	8 x M6	13	981	20239	29444	16147	1
1 1/4	1,2500	2,362	1,535	1,772	2,008	8 x M6	13	1033	20239	27972	14802	2
1 3/8	1,3750	2,362	1,535	1,772	2,008	8 x M6	13	1137	20239	25429	14802	2
1 7/16	1,4375	2,362	1,535	1,772	2,008	8 x M6	13	1188	20239	24323	14802	2
1 1/2	1,5000	2,953	2,205	2,520	2,835	8 x M8	30	2290	37394	29994	15237	2
1 5/8	1,6250	2,953	2,205	2,520	2,835	8 x M8	30	2481	37394	27687	15237	2
1 3/4	1,7500	2,953	2,205	2,520	2,835	8 x M8	30	2672	37394	25709	15237	2
1 7/8	1,8750	3,150	2,205	2,520	2,835	8 x M8	30	2863	37394	23996	14285	3
1 15/16	1,9375	3,150	2,205	2,520	2,835	8 x M8	30	2959	37394	23221	14285	3
2	2,0000	3,150	2,205	2,520	2,835	8 x M8	30	3054	37394	22496	14285	3
2 1/8	2,1250	3,346	2,205	2,520	2,835	8 x M8	30	3245	37394	21173	13445	3
2 3/16	2,1875	3,346	2,205	2,520	2,835	8 x M8	30	3340	37394	20568	13445	3
2 1/4	2,2500	3,543	2,205	2,520	2,835	10 x M8	30	4294	46743	24995	15872	4
2 3/8	2,3750	3,543	2,205	2,520	2,835	10 x M8	30	4533	46743	23680	15872	4
2 7/16	2,4375	3,740	2,205	2,520	2,835	10 x M8	30	4652	46743	23073	15037	4
2 1/2	2,5000	3,740	2,205	2,520	2,835	10 x M8	30	4772	46743	22496	15037	4
2 9/16	2,5625	3,740	2,205	2,520	2,835	10 x M8	30	4891	46743	21947	15037	4
2 5/8	2,6250	4,331	2,756	3,071	3,465	10 x M10	61	7956	74219	27215	16496	7
2 11/16	2,6875	4,331	2,756	3,071	3,465	10 x M10	61	8145	74219	26582	16496	7
2 3/4	2,7500	4,331	2,756	3,071	3,465	10 x M10	61	8334	74219	25978	16496	7
2 7/8	2,8750	4,331	2,756	3,071	3,465	10 x M10	61	8713	74219	24848	16496	7
2 15/16	2,9375	4,724	2,756	3,071	3,465	12 x M10	61	10683	89063	29183	18145	8
3	3,0000	4,724	2,756	3,071	3,465	12 x M10	61	10910	89063	28575	18145	8
3 1/8	3,1250	4,724	2,756	3,071	3,465	12 x M10	61	11365	89063	27432	18145	8
3 1/4	3,2500	4,724	2,756	3,071	3,465	12 x M10	61	11820	89063	26377	18145	8
3 3/8	3,3750	5,118	2,756	3,071	3,465	12 x M10	61	12274	89063	25400	16750	8
3 7/16	3,4375	5,118	2,756	3,071	3,465	12 x M10	61	12501	89063	24938	16750	8
3 1/2	3,5000	5,118	2,756	3,071	3,465	12 x M10	61	12728	89063	24493	16750	8
3 5/8	3,6250	5,118	2,756	3,071	3,465	12 x M10	61	13183	89063	23649	16750	8
3 3/4	3,7500	5,709	3,543	3,937	4,409	12 x M12	107	19857	129674	25888	17006	13
3 7/8	3,8750	5,709	3,543	3,937	4,409	12 x M12	107	20518	129674	25053	17006	13
3 15/16	3,9375	5,709	3,543	3,937	4,409	12 x M12	107	20850	129674	24655	17006	13
4	4,0000	5,709	3,543	3,937	4,409	12 x M12	107	21180	129674	24270	17006	13
4 1/4	4,2500	6,102	3,543	3,937	4,409	12 x M12	107	22504	129674	22842	15908	14
4 3/8	4,3750	6,102	3,543	3,937	4,409	12 x M12	107	23165	129674	22189	15908	14
4 7/16	4,4375	6,496	3,543	3,937	4,409	14 x M12	107	27413	151287	25523	17435	16
4 1/2	4,5000	6,496	3,543	3,937	4,409	14 x M12	107	27799	151287	25169	17435	16
4 3/4	4,7500	6,496	3,543	3,937	4,409	14 x M12	107	29343	151287	23844	17435	16
4 15/16	4,9375	7,087	4,094	4,567	5,118	12 x M14	170	35872	177925	23346	16266	22
5	5,0000	7,087	4,094	4,567	5,118	12 x M14	170	36327	177925	23054	16266	22
5 1/4	5,2500	7,480	4,094	4,567	5,118	14 x M14	170	44500	207579	25616	17978	22
5 7/16	5,4375	7,480	4,094	4,567	5,118	14 x M14	170	46089	207579	24732	17978	22
5 1/2	5,5000	7,480	4,094	4,567	5,118	14 x M14	170	46619	207579	24451	17978	22
5 3/4	5,7500	7,874	4,094	4,567	5,118	16 x M14	170	55700	237234	26729	19519	24
5 15/16	5,9375	7,874	4,094	4,567	5,118	16 x M14	170	57517	237234	25885	19519	24
6	6,0000	8,268	4,094	4,567	5,118	16 x M14	170	58123	237234	25616	18590	25
6 7/16	6,4375	8,858	5,276	5,748	6,378	14 x M16	262	75836	288500	22534	16376	37
6 1/2	6,5000	8,858	5,276	5,748	6,378	14 x M16	262	76572	288500	22317	16376	37
6 15/16	6,9375	9,252	5,276	5,748	6,378	16 x M16	262	93402	329715	23897	17919	41
7	7,0000	9,252	5,276	5,748	6,378	16 x M16	262	94244	329715	23684	17919	41
7 1/4	7,2500	9,843	5,276	5,748	6,378	16 x M16	262	97609	329715	22867	16844	47
7 7/16	7,4375	9,843	5,276	5,748	6,378	16 x M16	262	100133	329715	22290	16844	47
7 1/2	7,5000	9,843	5,276	5,748	6,378	16 x M16	262	100975	329715	22105	16844	47
7 3/4	7,7500	10,236	5,276	5,748	6,378	16 x M16	262	104341	329715	21392	16196	49
7 15/16	7,9375	10,236	5,276	5,748	6,378	16 x M16	262	106865	329715	20886	16196	49
8	8,0000	10,236	5,276	5,748	6,378	16 x M16	262	107707	329715	20723	16196	49

For larger diameter or inch series please contact us.

NOTE: it is possible to reduce the screws tightening torque down to 60% of the values indicated in above table; as a result M_t, F_{ass}, P_w, P_n are reduced proportionally.

TLK 451 / TLK 451.0

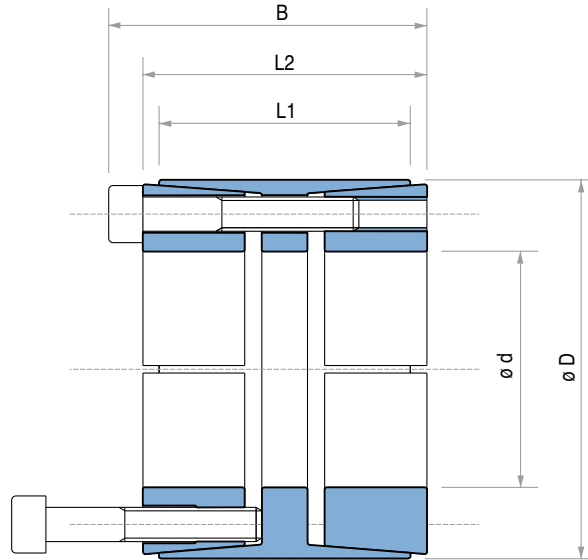

TLK 451 / TLK 451.0 DIMENSIONS

Dimensions						Screws	TLK 451	Torque	Axial	Surface pressures on		TLK 451.0	Torque	Axial	Surface pressures on		Weight
d x D	d	D	L1	L2	B	N° x	M _t	M _t	F _{ax}	P _s	P _h	M _t	M _t	F _{ax}	P _s	P _h	Lb
mm	inch	inch	inch	inch	inch	Type	Lb-ft	Lb-ft	Lbf	psi	psi	Lb-ft	Lb-ft	Lbf	psi	psi	
70 x 110	2,756	4,331	1,969	2,362	2,756	8 x M10	36	3083	26977	16389	9282	61	5229	45636	27847	15809	5,1
80 x 120	3,150	4,724	1,969	2,362	2,756	10 x M10	36	4411	33721	17985	10588	61	7472	56877	30458	17985	5,5
90 x 130	3,543	5,118	1,969	2,362	2,756	11 x M10	36	5458	37093	17550	10878	61	9249	62722	29733	18275	6,0
100 x 145	3,937	5,709	2,362	2,756	3,228	10 x M12	63	8062	49233	17550	10733	107	13601	82955	29588	18130	9,0
110 x 155	4,331	6,102	2,362	2,756	3,228	10 x M12	63	8851	49233	15954	10008	107	14899	82955	26832	16969	9,7
120 x 165	4,724	6,496	2,362	2,756	3,228	11 x M12	63	10621	54179	16099	10443	107	17923	91272	27122	17550	10,6
130 x 180	5,118	7,087	2,559	3,110	3,583	14 x M12	63	14677	68792	17114	11168	107	24708	116001	28863	18710	13,9
140 x 190	5,512	7,480	2,559	3,110	3,583	15 x M12	63	16890	73737	16969	11313	107	28544	124319	28717	19000	14,6
150 x 200	5,906	7,874	2,559	3,110	3,583	15 x M12	63	18144	73737	15954	10733	107	30535	124319	26832	17985	17,2
160 x 210	6,299	8,268	2,559	3,110	3,583	16 x M12	63	20652	78683	15954	10878	107	34813	132637	26832	18275	16,3
170 x 225	6,693	8,858	3,071	3,622	4,173	15 x M14	100	27880	100265	15809	10733	170	47573	170630	26832	18275	23,6
180 x 235	7,087	9,252	3,071	3,622	4,173	15 x M14	100	29576	100265	14939	10298	170	50375	170630	25382	17550	24,9
190 x 250	7,480	9,843	3,465	4,016	4,567	16 x M14	100	33264	106784	13053	8992	170	56719	182095	22191	15374	32,2
200 x 260	7,874	10,236	3,465	4,016	4,567	18 x M14	100	39386	120273	13924	9718	170	67192	204801	23641	16679	33,7
220 x 285	8,661	11,220	3,780	4,252	4,882	15 x M16	155	50597	140281	13634	9572	262	85557	237173	23061	16244	44,5
240 x 305	9,449	12,008	3,780	4,252	4,882	20 x M16	155	73609	187041	16679	11893	262	124500	316306	28137	20160	48,1
260 x 325	10,236	12,795	3,780	4,252	4,882	20 x M16	155	79657	187041	15374	11168	262	134236	316306	25962	18855	51,6
280 x 355	11,024	13,976	3,780	4,331	5,118	15 x M20	302	101046	220088	17695	12328	509	169639	370260	29733	20740	66,1
300 x 375	11,811	14,764	3,780	4,331	5,118	16 x M20	302	115060	234701	17550	12473	509	193979	394989	29588	21030	68,8
320 x 405	12,598	15,945	4,882	5,354	6,142	20 x M20	302	153413	293376	15084	10878	509	258884	493680	25382	18275	105,8
340 x 425	13,386	16,732	4,882	5,354	6,142	20 x M20	302	163001	293376	14214	10298	509	275111	493680	23931	17405	112,4
360 x 455	14,173	17,913	5,512	6,102	6,969	20 x M22	406	214631	363516	14649	10588	686	362881	614628	24801	17985	152,1
380 x 475	14,961	18,701	5,512	6,102	6,969	20 x M22	406	226432	363516	13924	10153	686	382795	614628	23496	17114	160,9
400 x 495	15,748	19,488	5,512	6,102	6,969	22 x M22	406	261835	399710	14504	10733	686	443275	676000	24511	18130	167,6
420 x 515	16,535	20,276	5,512	6,102	6,969	24 x M22	406	300188	436129	15084	11168	686	507443	737373	25527	19000	176,4
440 x 535	17,323	21,063	5,512	6,102	6,969	24 x M22	406	314201	436129	14359	10878	686	531782	737373	24366	18275	178,6
460 x 555	18,110	21,850	5,512	6,102	6,969	24 x M22	406	328953	436129	13779	10443	686	556122	737373	23206	17695	187,4
480 x 575	18,898	22,638	5,512	6,102	6,969	25 x M22	406	357718	454339	13779	10443	686	604801	768172	23206	17695	194,0
500 x 595	19,685	23,425	5,512	6,102	6,969	25 x M22	406	372469	454339	13198	10153	686	629878	768172	22336	17114	200,6
520 x 615	20,472	24,213	5,512	6,102	6,969	28 x M22	406	433687	508743	14214	11023	686	733874	860344	23931	18565	209,4
540 x 635	21,260	25,000	5,512	6,102	6,969	28 x M22	406	450650	508743	13634	10588	686	761902	860344	23061	17985	216,1
560 x 655	22,047	25,787	5,512	6,102	6,969	30 x M22	406	500805	545162	14069	11023	686	846721	921941	23931	18710	222,7
580 x 675	22,835	26,575	5,512	6,102	6,969	30 x M22	406	518506	545162	13634	10733	686	876961	921941	23061	18130	229,3
600 x 695	23,622	27,362	5,512	6,102	6,969	30 x M22	406	536208	545162	13198	10443	686	907201	921941	22336	17550	238,1

For larger diameter or inch series please contact us.

TLK 452

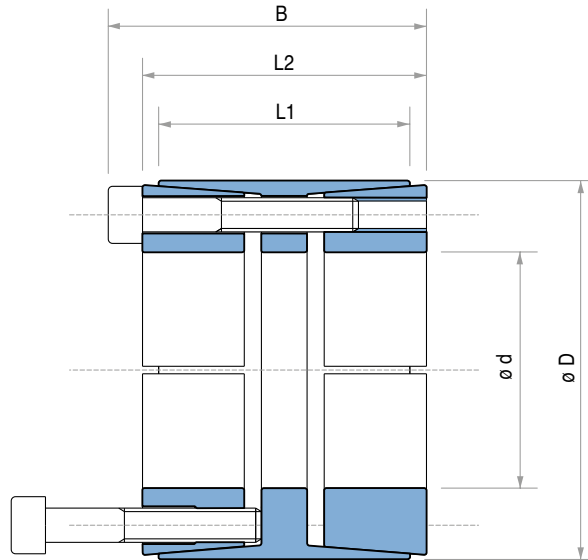

TLK 452 DIMENSIONS

Dimensions						Tightening screws		Torque	Axial force	Surface pressures on		Weight
						DIN912 12.9	Tightening torque			Shaft	Hub	
d x D mm	d inch	D inch	L1 inch	L2 inch	B inch	N° x Type	M _t Lb-ft	M _t Lb-ft	F _{ax} Lbf	P _s psi	P _h psi	Lb
25 x 55	0,984	2,165	1,260	1,575	1,811	6 x M6	13	634	15603	44504	15172	1,0
28 x 55	1,102	2,165	1,260	1,575	1,811	6 x M6	13	715	15603	39736	15172	1,0
30 x 55	1,181	2,165	1,260	1,575	1,811	6 x M6	13	767	15603	37087	15172	0,9
35 x 60	1,378	2,362	1,732	2,126	2,362	7 x M6	13	1040	18204	26179	11800	1,4
38 x 75	1,496	2,953	1,732	2,126	2,441	7 x M8	30	2095	33635	44552	17443	2,5
40 x 75	1,575	2,953	1,732	2,126	2,441	7 x M8	30	2205	33635	42324	17443	2,4
42 x 75	1,654	2,953	1,732	2,126	2,441	7 x M8	30	2316	33635	40309	17443	2,3
45 x 75	1,772	2,953	1,732	2,126	2,441	7 x M8	30	2478	33635	37621	17443	2,1
48 x 80	1,890	3,150	2,205	2,520	2,835	8 x M8	30	3024	38440	29793	14684	3,1
50 x 80	1,969	3,150	2,205	2,520	2,835	8 x M8	30	3149	38440	28602	14684	2,9
55 x 85	2,165	3,346	2,205	2,520	2,835	9 x M8	30	3894	43245	29252	15548	3,2
60 x 90	2,362	3,543	2,205	2,520	2,835	10 x M8	30	4728	48050	29793	16315	3,4
65 x 95	2,559	3,740	2,205	2,520	2,835	10 x M8	30	5119	48050	27502	15457	3,6
70 x 110	2,756	4,331	2,756	3,071	3,465	10 x M10	61	8703	76294	32159	16957	6,8
75 x 115	2,953	4,528	2,756	3,071	3,465	10 x M10	61	9367	76294	30015	16219	7,2
80 x 120	3,150	4,724	2,756	3,071	3,465	11 x M10	61	10990	83924	30953	17098	7,6
85 x 125	3,346	4,921	2,756	3,071	3,465	12 x M10	61	12760	91553	31781	17906	7,9
90 x 130	3,543	5,118	2,756	3,071	3,465	12 x M10	61	13497	91553	30015	17217	8,3
95 x 135	3,740	5,315	2,756	3,071	3,465	12 x M10	61	14235	91553	28435	16580	8,7
100 x 145	3,937	5,709	3,543	3,937	4,409	11 x M12	107	19988	122191	29873	16024	13,4
110 x 155	4,331	6,102	3,543	3,937	4,409	12 x M12	107	24045	133300	29626	16353	14,5
120 x 165	4,724	6,496	3,543	3,937	4,409	14 x M12	107	30609	155516	31683	17922	15,6
130 x 180	5,118	7,087	4,094	4,567	5,118	12 x M14	170	38943	182899	28663	16720	21,8
140 x 190	5,512	7,480	4,094	4,567	5,118	14 x M14	170	48974	213383	31052	18480	23,2
150 x 200	5,906	7,874	4,094	4,567	5,118	15 x M14	170	56202	228624	31052	18810	24,6
160 x 210	6,299	8,268	4,094	4,567	5,118	16 x M14	170	63947	243866	31052	19109	26,0
170 x 225	6,693	8,858	5,276	5,827	6,457	14 x M16	266	82607	296566	28433	16833	39,3
180 x 235	7,087	9,252	5,276	5,827	6,457	15 x M16	266	93670	317749	28771	17268	41,3
190 x 250	7,480	9,843	5,276	5,827	6,457	16 x M16	266	105471	338932	29074	17314	47,8
200 x 260	7,874	10,236	5,276	5,827	6,457	16 x M16	266	110634	338932	27620	16648	49,9
220 x 285	8,661	11,220	5,276	5,827	6,457	18 x M16	266	137187	381299	28248	17086	59,4
240 x 305	9,449	12,008	5,276	5,906	6,535	20 x M16	266	166689	423665	28771	17740	64,1
260 x 325	10,236	12,795	5,276	5,906	6,535	21 x M16	266	189553	444849	27886	17481	68,8
280 x 355	11,024	13,976	6,496	6,969	7,756	18 x M20	509	272898	595198	28644	17389	106,1
300 x 375	11,811	14,764	6,496	6,969	7,756	20 x M20	509	325265	661331	29705	18291	112,8
320 x 405	12,598	15,945	6,496	6,969	7,756	21 x M20	509	364356	694398	29241	17783	137,3
340 x 425	13,386	16,732	6,496	6,969	7,756	22 x M20	509	405659	727465	28831	17753	144,9
360 x 455	14,173	17,913	7,480	7,953	8,819	21 x M22	686	510393	864381	27953	17111	198,7
380 x 475	14,961	18,701	7,480	7,953	8,819	22 x M22	686	564235	905542	27742	17171	208,4
400 x 495	15,748	19,488	7,480	7,953	8,819	24 x M22	686	647580	987864	28751	17975	218,2

For larger diameter or inch series please contact us. NOTE: it is possible to reduce the screws tightening torque down to 60% of the values indicated in above table; as a result M_t, F_{ax}, P_s, P_h are reduced proportionally.

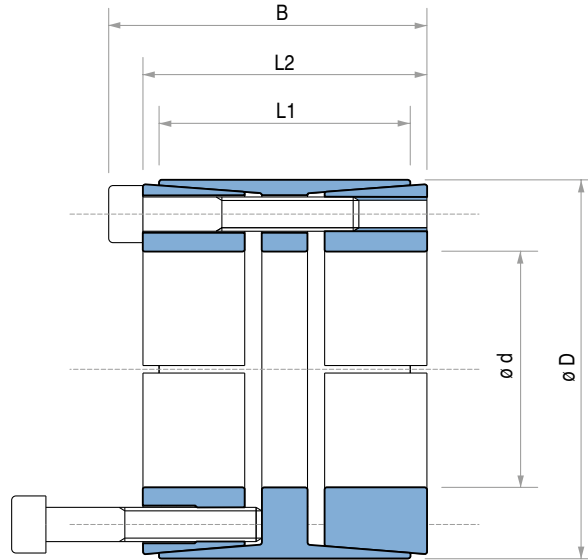

TLK 452 DIMENSIONS

Dimensions						Torque (max.) M_t Lb-ft	Axial Thrust (max.) F_{ax} Lbf	Surface pressures on		Tightening screws		Weight (approx.) Lb
d inch	d inch	D inch	L1 inch	L2 inch	B inch			P_s psi	P_h psi	DIN 912 12.9 n x type	Tightening torque M_s Lb-ft	
4	4,0000	5,709	3,543	3,937	4,409	20357	122191	29403	16024	11 x M12	107	13
4 1/4	4,2500	6,102	3,543	3,937	4,409	23602	133300	30189	16353	12 x M12	107	15
4 3/8	4,3750	6,102	3,543	3,937	4,409	24266	133300	29326	16353	12 x M12	107	14
4 7/16	4,4380	6,496	3,543	3,937	4,409	28691	155516	33728	17922	14 x M12	107	18
4 1/2	4,5000	6,496	3,543	3,937	4,409	29134	155516	33263	17922	14 x M12	107	17
4 3/4	4,7500	6,496	3,543	3,937	4,409	30756	155516	31513	17922	14 x M12	107	15
4 15/16	4,9380	7,087	4,094	4,567	5,118	37616	182899	29709	16720	12 x M14	170	23
5	5,0000	7,087	4,094	4,567	5,118	38058	182899	29340	16720	12 x M14	170	23
5 1/4	5,2500	7,480	4,094	4,567	5,118	46614	213383	32600	18480	14 x M14	170	26
5 7/16	5,4380	7,480	4,094	4,567	5,118	48310	213383	31473	18480	14 x M14	170	24
5 1/2	5,5000	7,480	4,094	4,567	5,118	48827	213383	31119	18480	14 x M14	170	23
5 3/4	5,7500	7,874	4,094	4,567	5,118	54727	228624	31892	18810	15 x M14	170	26
5 15/16	5,9380	7,874	4,094	4,567	5,118	56497	228624	30882	18810	15 x M14	170	24
6	6,0000	8,268	4,094	4,567	5,118	60923	243866	32600	19109	16 x M14	170	29
6 7/16	6,4380	8,858	5,276	5,827	6,457	79509	296566	29559	16833	14 x M16	262	43
6 1/2	6,5000	8,858	5,276	5,827	6,457	80247	296566	29277	16833	14 x M16	262	42
6 15/16	6,9380	9,252	5,276	5,827	6,457	91826	317749	29388	17268	15 x M16	262	44
7	7,0000	9,252	5,276	5,827	6,457	92638	317749	29127	17268	15 x M16	262	43
7 1/4	7,2500	9,843	5,276	5,827	6,457	102374	338932	29998	17314	16 x M16	262	52
7 7/16	7,4380	9,843	5,276	5,827	6,457	105029	338932	29240	17314	16 x M16	262	49
7 1/2	7,5000	9,843	5,276	5,827	6,457	105914	338932	28998	17314	16 x M16	262	47
7 3/4	7,7500	10,236	5,276	5,827	6,457	109380	338932	28062	16648	16 x M16	262	52
7 15/16	7,9380	10,236	5,276	5,827	6,457	112036	338932	27398	16648	16 x M16	262	49
8	8,0000	10,236	5,276	5,827	6,457	112921	338932	27185	16648	16 x M16	262	48

For larger diameter or inch series please contact us.

NOTE: it is possible to reduce the screws tightening torque down to 60% of the values indicated in above table; as a result M_t , F_{ax} , P_w , P_n are reduced proportionally.

TLK 500

TLK 500 DIMENSIONS

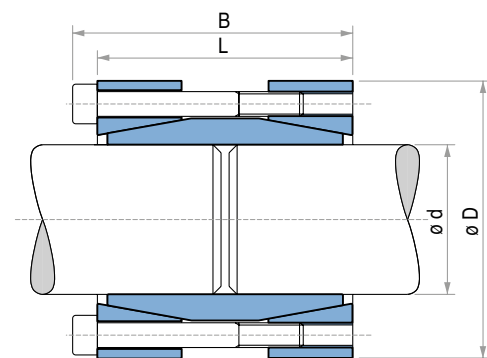

Standard version

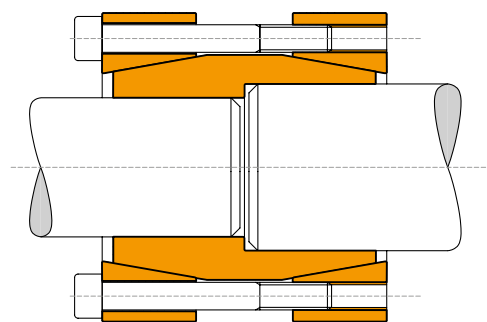

Double diameter versions are available

Dimensions					Torque	Axial force	Tightening screws		Weight
d x D	d	D	L	B			DIN912 12.9	Tightening torque	
mm	inch	inch	inch	inch	M _t Lb-ft	F _{ax} Lbf	Type	M _t Lb-ft	Lb
17 x 50	0,669	1,969	1,969	2,205	148	5395	4 x M6	13	1,1
18 x 50	0,709	1,969	1,969	2,205	162	5395	4 x M6	13	1,1
19 x 50	0,748	1,969	1,969	2,205	170	5395	4 x M6	13	1,1
20 x 50	0,787	1,969	1,969	2,205	177	5395	4 x M6	13	1,1
22 x 55	0,866	2,165	2,362	2,598	192	5395	4 x M6	13	1,3
24 x 55	0,945	2,165	2,362	2,598	214	5395	4 x M6	13	1,3
25 x 55	0,984	2,165	2,362	2,598	332	8093	6 x M6	13	1,3
28 x 60	1,102	2,362	2,362	2,598	376	8093	6 x M6	13	1,5
30 x 60	1,181	2,362	2,362	2,598	406	8093	6 x M6	13	1,5
32 x 75	1,260	2,953	2,362	2,677	531	10116	4 x M8	30	2,9
35 x 75	1,378	2,953	2,953	3,268	583	10116	4 x M8	30	2,9
38 x 75	1,496	2,953	2,953	3,268	627	10116	4 x M8	30	2,9
40 x 75	1,575	2,953	2,953	3,268	664	10116	4 x M8	30	2,9
42 x 90	1,654	3,543	2,953	3,268	1033	15062	6 x M8	30	6,2
45 x 90	1,772	3,543	3,346	3,661	1121	15062	6 x M8	30	5,5
48 x 90	1,890	3,543	3,346	3,661	1195	15062	6 x M8	30	5,3
50 x 90	1,969	3,543	3,346	3,661	1246	15062	6 x M8	30	5,1
55 x 105	2,165	4,134	3,346	3,661	1822	20233	8 x M8	30	7,3
60 x 105	2,362	4,134	3,346	3,661	1999	20233	8 x M8	30	7,1
65 x 105	2,559	4,134	3,346	3,661	2161	20233	8 x M8	30	6,6
70 x 125	2,756	4,921	3,937	4,331	2781	24055	6 x M10	61	11,9
75 x 125	2,953	4,921	3,937	4,331	2972	24055	6 x M10	61	11,0
80 x 125	3,150	4,921	3,937	4,331	3172	24055	6 x M10	61	10,4

For larger diameter or inch series please contact us.

Characteristics

- Medium high torque
- Less number of tightening screws
- Easy installation
- Application economically advantageous

Installation

Carefully clean the shafts contact surfaces. Fit the rigid coupling at the end of the connecting shafts. Tighten gradually and regularly in crossed sequence all screws to reach the tightening torque M_t indicated on the table.

Dismantling

By loosening all tightening screws the clamping cones are normally released. However in case of difficulties slightly hammer the released screws in a way to push back the rear pressure cone.

Tolerances, surface finish

A good surface finish by the machine tool is sufficient.

Maximum allowable surface finish:

Rt max 16 μm (Ra 3 μm - Rz 13 μm)

Maximum permissible tolerances:

h8 for shaft

For exact tolerance values see page 57.

TLK 603 TLK 602 TLK 601

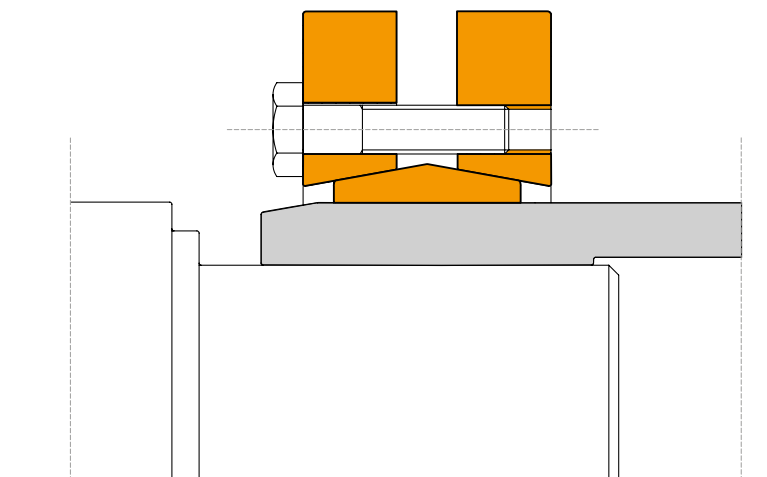

Characteristics

- Medium-high torque
- No shaft-hub axial movement
- Quick installation time
- Low inertia

Installation

Carefully clean the hub and shaft contact surfaces. Slide the shrink disc outside the hollow shaft. Tighten gradually and regularly in continuous sequence all screws to reach the tightening torque M_s indicated in the table.

To reach the required tightening torque M_s it is necessary to repeat the procedure more than once.

Do not use **molybdenum bisulphide** in the hub and shaft contact surfaces.

Dismantling

Loosen the clamping screws in a continuous and gradual sequence. Do not remove screws from threads. Normally with this operation the shrink disc is released.

In case of reuse, apply a solid lubricant (that can guarantee a friction coefficient equal to 0,04) in the screws and in the tapered surfaces.

Tolerances, surface finish

A good surface finish by the machine tool is sufficient.

Maximum allowable surface finish:

Rt max 16 μm (Ra 3 μm - Rz 13 μm)

Maximum permissible tolerances:

d = h8 for hub o.d.

Dw diameter tolerances

From 0.4 to 1.2 inch	H6/j6
From 1.2 to 2.0 inch	H6/h6
From 2.0 to 3.2 inch	H6/g6
From 3.2 to 19.7 inch	H7/g6

For exact tolerance values see page 57.

Axial movement

During screws tightening the hub has no axial movement with respect to the shaft.

TLK 603 DIMENSIONS

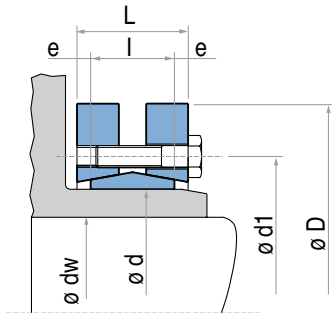

Type	Shaft diameter	Torque	Axial force	Dimensions					Tightening screws		Weight	
				DIN 931 10.9	Tightening torque	D	l	L	d1	e		N° x Type
d mm	d inch	dw inch	M _t Lb-ft	F _{ax} Lbf	D inch	l inch	L inch	d1 inch	e inch			
14	0,5512	0,433 0,472	22 37	1349 2023	1,496	0,276	0,433	0,906	0,079	4 x M5*	3	0,2
16	0,6299	0,512 0,551	52 66	2248 2923	1,614	0,433	0,591	1,024	0,079	5 x M5*	3	0,2
24	0,9449	0,748 0,787 0,827	125 155 184	5620 6070 6519	1,969	0,551	0,768	1,417	0,108	6 x M5*	3	0,4
30	1,1811	0,945 0,984 1,024	221 251 280	6519 6969 7419	2,362	0,630	0,846	1,732	0,108	7 x M5*	3	0,7
36	1,4173	1,102 1,181 1,220	325 420 465	11240 13039 13039	2,835	0,709	0,925	2,047	0,108	5 x M6	9	0,9
44	1,7323	1,260 1,378 1,417	457 575 634	14388 16636 17310	3,150	0,787	1,004	2,402	0,108	7 x M6	9	1,3
50	1,9685	1,496 1,575 1,654	693 856 1018	17760 19334 20682	3,543	0,866	1,083	2,756	0,108	8 x M6	9	1,8
55	2,1654	1,654 1,772 1,890	856 1121 1387	17760 19783 21806	3,937	0,906	1,201	2,953	0,148	8 x M6	9	2,4
62	2,4409	1,890 1,969 2,047	1364 1623 1770	22481 24954 26303	4,331	0,906	1,201	3,386	0,148	10 x M6	9	2,9
68	2,6772	1,969 2,165 2,362	1475 1844 2323	21806 23830 26977	4,528	0,906	1,201	3,386	0,148	10 x M6	9	3,1
75	2,9528	2,165 2,362 2,559	1844 2360 2913	26752 30799 34845	5,433	0,984	1,280	3,937	0,148	7 x M8	22	3,7
80	3,1496	2,362 2,559 2,756	2360 2876 3393	27876 31473 35520	5,709	0,984	1,280	3,937	0,148	7 x M8	22	4,2
85	3,3465	2,559 2,756 2,953	3540 4499 5458	39342 43838 48559	6,102	1,181	1,535	4,488	0,177	10 x M8	22	7,7
90	3,5433	2,559 2,756 2,953	3503 4425 5347	38218 42714 47210	6,102	1,181	1,535	4,488	0,177	10 x M8	22	7,3
100	3,9370	2,756 2,953 3,150	5089 5532 6638	43838 49458 53954	6,693	1,339	1,732	4,882	0,197	12 x M8	22	10,4
110	4,3307	2,953 3,150 3,346	5310 6638 7966	51481 56652 58900	7,283	1,535	1,969	5,354	0,217	9 x M10	44	13,0
115	4,5276	3,150 3,346 3,543	5458 6786 8187	52830 58226 60474	7,402	1,535	1,969	5,551	0,217	9 x M10	44	12,1
120	4,7244	3,150 3,346 3,543	7818 9810 10695	64071 70590 76435	8,465	1,654	2,126	6,299	0,236	12 x M10	44	19,8
125	4,9213	3,346 3,543 3,740	8113 9588 11063	66543 72838 79133	8,465	1,654	2,126	6,299	0,236	12 x M10	44	18,3
130	5,1181	3,543 3,740 3,937	8334 9810 11358	68342 74861 81381	8,465	1,654	2,126	6,299	0,236	12 x M10	44	17,6
140	5,5118	3,740 3,937 4,134	11137 12981 14825	82505 89024 95544	9,055	1,811	2,382	6,890	0,285	10 x M12	74	22,0
155	6,1024	4,134 4,331 4,528	16226 18439 20652	100490 107459 114428	10,433	1,969	2,539	7,559	0,285	12 x M12	74	33,1
160	6,2992	4,331 4,528 4,724	16669 18955 21242	103412 110156 116901	10,433	1,969	2,539	7,559	0,285	12 x M12	74	32,0
165	6,4961	4,528 4,724 4,921	22864 25815 28765	133761 141630 147250	11,417	2,205	2,795	8,268	0,295	8 x M16	184	48,5

For larger diameter please contact our application engineering department.
*8.8 screws

TLK 603 DIMENSIONS

Type	Shaft diameter	Torque	Axial force	Dimensions					Tightening screws		Weight	
				DIN 931 10.9	Tightening torque	D	I	L	d1	e		N° x Type
d mm	d inch	dw inch	M _t Lb-ft	F _{ax} Lbf	D inch	I inch	L inch	d1 inch	e inch	N° x Type	Ms Lb-ft	Lb
170	6,6929	4,724	23528	137133	11,417	2,205	2,795	8,268	0,295	8 x M16	184	46,3
		4,921 5,118	26552 29576	143878 150622								
175	6,8898	4,921	26552	136009	11,811	2,205	2,795	8,661	0,295	8 x M16	184	48,5
		5,118 5,315	30240 33190	143653 151746								
180	7,0866	5,118	27290	179847	11,811	2,205	2,795	8,661	0,295	8 x M16	184	46,3
		5,315 5,512	31125 34149	188840 198956								
185	7,2835	5,315	38353	174901	12,992	2,795	3,386	9,291	0,295	10 x M16	184	81,6
		5,512 5,709	42041 45729	184119 193561								
190	7,4803	5,512	39460	179847	12,992	2,795	3,386	9,291	0,295	10 x M16	184	79,4
		5,709 5,906	43295 47056	188840 198956								
195	7,6772	5,512	47942	209747	13,780	2,795	3,386	9,685	0,295	12 x M16	184	90,4
		5,906 6,102	56055 60111	230429 240770								
200	7,8740	5,906	54580	222561	13,780	2,795	3,386	9,685	0,295	12 x M16	184	90,4
		6,102 6,299	59005 63430	232677 242794								
220	8,6614	6,299	70068	267523	14,567	3,465	4,094	10,630	0,315	15 x M16	184	119,0
		6,496 6,693	75231 81132	278538 290004								
240	9,4488	6,693	88507	329120	15,945	3,622	4,291	11,614	0,335	12 x M20	361	147,7
		7,087 7,480	101784 115060	354299 376555								
260	10,2362	7,480	120960	395664	16,929	4,055	4,724	12,638	0,335	14 x M20	361	180,8
		7,874 8,268	135711 151200	422641 451866								
280	11,0236	8,268	160051	469851	18,110	4,488	5,276	13,622	0,394	16 x M20	361	224,9
		8,661 9,055	179965 199142	499076 528301								
300	11,8110	9,055	202830	546511	19,094	4,803	5,591	14,331	0,394	18 x M20	361	260,1
		9,449 9,646	217581 232332	577085 592596								
320	12,5984	9,449	230119	595069	20,472	4,803	5,591	15,197	0,394	20 x M20	361	288,8
		9,843 10,236	250771 275848	626318 651946								
340	13,3858	9,843	287649	701179	22,441	5,276	6,142	16,063	0,433	24 x M20	361	410,1
		10,236 10,630	311620 339279	730404 764350								
350	13,7795	10,630	326002	736474	22,835	5,512	6,378	17,008	0,433	24 x M20	361	429,9
		11,024 11,220	354030 368781	771095 786831								
360	14,1732	11,024	341491	744118	23,228	5,512	6,378	17,008	0,433	24 x M20	361	449,7
		11,417 11,614	370256 385007	778064 794924								
380	14,9606	11,417	418198	879003	25,394	5,669	6,614	18,031	0,472	20 x M24	620	526,9
		11,811 12,205	449913 485316	917220 954988								
390	15,3543	11,811	460239	935205	25,984	5,669	6,614	18,425	0,472	21 x M24	620	573,2
		12,205 12,598	494904 529570	973423 1008043								
400	15,7480	12,402	494167	957686	26,772	5,669	6,614	18,898	0,472	21 x M24	620	617,3
		12,598 12,992	512606 548746	976795 1011640								
420	16,5354	12,992	575298	1090323	27,165	6,457	7,402	19,843	0,472	24 x M24	620	696,7
		13,386 13,780	619552 663806	1133037 1173503								
440	17,3228	13,386	594475	1065594	29,528	6,969	7,953	20,748	0,492	24 x M24	620	899,5
		13,780 14,173	634303 676344	1103812 1144278								
460	18,1102	14,173	737562	1274667	30,315	6,969	7,953	21,535	0,492	28 x M24	620	925,9
		14,567 14,961	789191 840821	1317380 1360094								
480	18,8976	14,961	862948	1382575	31,496	7,402	8,386	22,441	0,492	30 x M24	620	1113,3
		15,354 15,748	914577 966206	1427537 1472499								

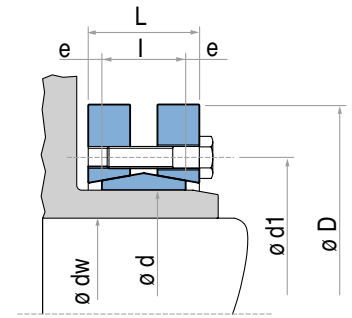

For larger diameter please contact our application engineering department.
*8.8 screws

TLK 602

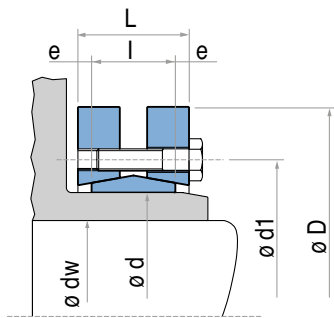

Type	Shaft diameter	Torque	Axial force	Dimensions					Tightening screws		Weight	
									DIN 931 10.9	Tightening torque		
d mm	d inch	dw inch	M _t Lb-ft	F _{ax} Lbf	D inch	l inch	L inch	d1 inch	e inch	N° x Type	Ms Lb-ft	Lb
125	4,9213	3,346	11063	79807	8,465	2,165	2,559	6,299	0,197	10 x M12	74	24,3
		3,543	12907	87226								
		3,740	14751	94869								
140	5,5118	3,740	15194	97342	9,055	2,362	2,913	6,890	0,276	12 x M12	74	28,7
		3,937	17333	105435								
		4,134	19545	112404								
155	6,1024	4,134	21094	123645	10,433	2,598	3,150	7,795	0,276	15 x M12	74	44,1
		4,331	23971	132637								
		4,528	26847	141630								
165	6,4961	4,528	30240	166359	11,417	2,835	3,465	8,268	0,315	10 x M16	184	57,3
		4,724	33928	176475								
		4,921	37394	183219								
175	6,8898	4,921	34665	168607	11,811	2,835	3,465	8,661	0,315	10 x M16	184	63,9
		5,118	38353	178723								
		5,315	42041	188840								
185	7,2835	5,315	53104	247290	12,992	3,622	4,409	9,291	0,394	14 x M16	184	103,6
		5,512	57530	258530								
		5,709	63430	269771								
195	7,6772	5,512	55317	241670	13,780	3,622	4,409	9,685	0,394	14 x M16	184	116,8
		5,906	64905	265275								
		6,102	70806	277639								
200	7,8740	5,709	62693	263026	13,780	3,622	4,409	9,685	0,394	15 x M16	184	110,2
		5,906	68224	276515								
		6,102	73756	290004								
220	8,6614	6,299	93670	357446	14,567	4,488	5,276	10,630	0,394	20 x M16	184	143,3
		6,496	100308	370935								
		6,693	108053	386671								
240	9,4488	6,693	114322	409152	15,945	4,724	5,669	11,614	0,472	15 x M20	361	191,8
		7,087	129811	440626								
		7,480	146037	467603								
260	10,2362	7,480	157101	508068	16,929	5,354	6,299	12,638	0,472	18 x M20	361	220,5
		7,874	177015	544038								
		8,268	197667	580007								
280	11,0236	8,268	210205	615977	18,110	5,827	6,772	13,622	0,472	21 x M20	361	291,0
		8,661	236020	654194								
		9,055	261835	694660								
300	11,8110	9,055	251509	665434	19,094	5,984	6,929	14,331	0,472	22 x M20	361	308,6
		9,449	277323	703652								
		9,646	290599	722761								
320	12,5984	9,449	278798	708148	20,472	6,299	7,244	15,197	0,472	24 x M20	361	363,8
		9,843	306088	747490								
		10,236	332641	780087								
340	13,3858	9,843	361037	879003	22,441	6,929	7,874	16,535	0,472	21 x M24	620	529,1
		10,236	390908	916096								
		10,630	426311	961058								
350	13,7795	10,630	410085	926662	22,835	6,929	7,874	16,732	0,472	21 x M24	620	544,5
		11,024	445488	971175								
		11,220	463927	992531								
360	14,1732	11,024	451388	982415	23,228	7,087	8,031	17,008	0,472	22 x M24	620	551,2
		11,417	489004	1027377								
		11,614	508180	1049858								
380	14,9606	11,417	455813	959934	25,394	7,087	8,031	18,031	0,472	22 x M24	620	705,5
		11,811	492691	1001524								
		12,205	530307	1044238								
390	15,3543	11,811	522194	1059974	25,984	7,402	8,346	18,425	0,472	24 x M24	620	771,6
		12,205	562022	1103812								
		12,598	600744	1144278								
400	15,7480	12,402	564235	1091447	26,772	7,402	8,346	18,898	0,472	24 x M24	620	815,7
		12,598	581199	1107634								
		12,992	623240	1152146								
420	16,5354	12,992	736825	1361218	27,165	8,425	9,370	19,843	0,472	30 x M24	620	903,9
		13,386	787716	1412924								
		13,780	840821	1464630								
440	17,3228	13,386	780341	1400560	29,528	8,819	9,921	20,748	0,551	24 x M27	922	1157,4
		13,780	833445	1452266								
		14,173	888025	1503972								
460	18,1102	14,173	973582	1672579	30,315	8,819	9,921	21,535	0,551	28 x M27	922	1190,5
		14,567	1047338	1731029								
		14,961	1106343	1787231								

For larger diameter please contact our application engineering department.

TLK 601

Type	Shaft diameter	Torque	Axial force	Dimensions					Tightening screws		Weight	
				D	I	L	d1	e	DIN 931 10.9	Tightening torque		
d mm	d inch	dw inch	M _t Lb-ft	F _{ax} Lbf	D inch	I inch	L inch	d1 inch	e inch	N° x Type	Ms Lb-ft	Lb
125	4,9213	3,740	7781	49458	7,283	1,535	2,008	6,220	0,236	8 x M10	44	13,2
		3,937	8925	53954								
		4,134	10178	58450								
140	5,5118	4,331	10916	59574	8,661	1,535	2,008	6,890	0,236	9 x M10	44	17,6
		4,724	13748	69691								
		4,921	15120	73063								
155	6,1024	5,118	17701	82055	9,646	1,535	2,008	7,559	0,236	11 x M10	44	22,0
		5,315	19472	87675								
		5,512	21389	92172								
165	6,4961	5,315	23602	106784	10,236	1,811	2,441	8,268	0,315	10 x M12	74	30,9
		5,512	25962	112404								
		5,709	28396	119149								
175	6,8898	5,709	28765	120273	10,827	1,811	2,441	8,661	0,315	11 x M12	74	35,3
		5,906	31273	125893								
		6,102	33928	132637								
185	7,2835	6,102	34370	134885	11,614	1,811	2,441	8,858	0,315	12 x M12	74	44,1
		6,299	37099	140506								
		6,496	39828	146126								
195	7,6772	6,496	46466	170855	12,402	2,205	2,835	9,331	0,315	15 x M12	74	59,5
		6,693	49933	178723								
		6,890	53473	185467								
200	7,8740	6,890	54580	191088	12,992	2,205	2,835	9,528	0,315	16 x M12	74	66,1
		7,087	58636	200080								
		7,283	62324	205700								
220	8,6614	7,087	61070	206824	13,583	2,598	3,307	10,433	0,354	10 x M16	184	77,2
		7,480	68962	220313								
		7,874	77444	237173								
240	9,4488	7,874	83345	255158	14,567	2,598	3,307	11,417	0,354	12 x M16	184	97,0
		8,268	94039	272019								
		8,465	99202	281011								
260	10,2362	8,661	109897	303492	15,551	2,835	3,622	12,205	0,394	14 x M16	184	105,8
		9,055	121698	322601								
		9,252	127598	331593								
280	11,0236	9,055	126123	333841	16,732	3,307	4,094	13,110	0,394	16 x M16	184	132,3
		9,449	139399	352950								
		9,843	153413	373183								
300	11,8110	9,843	158576	386671	18,110	3,307	4,094	14,094	0,394	18 x M16	184	165,3
		10,236	172590	404656								
		10,630	188078	424889								
320	12,5984	10,630	191766	436129	19,488	3,307	4,173	14,882	0,433	20 x M16	184	185,2
		11,024	209468	456362								
		11,417	225694	477719								
340	13,3858	11,417	221269	465355	21,063	3,307	4,173	15,827	0,433	21 x M16	184	220,5
		11,811	239265	485587								
		12,008	248558	496828								
350	13,7795	11,811	274373	558650	21,457	3,937	4,803	16,260	0,433	16 x M20	361	264,6
		12,008	283961	571015								
		12,205	295025	582255								
360	14,1732	11,811	265522	539541	21,850	3,937	4,803	16,654	0,433	16 x M20	361	275,6
		12,205	286174	562022								
		12,598	306088	582255								
380	14,9606	12,598	320840	611480	23,031	4,409	5,354	17,402	0,472	18 x M20	361	330,7
		12,795	332641	624969								
		12,992	344442	637333								
390	15,3543	12,992	372469	687915	23,425	4,409	5,354	17,795	0,472	20 x M20	361	343,9
		13,386	398284	713768								
		13,780	425573	740745								
400	15,7480	13,386	405659	727257	24,213	4,409	5,354	18,189	0,472	21 x M20	361	374,8
		13,780	432949	755358								
		14,173	461714	782335								
420	16,5354	13,780	426311	741870	24,803	4,724	5,669	19,094	0,472	22 x M20	361	407,9
		14,173	455076	769971								
		14,567	483103	796948								
440	17,3228	14,567	499330	822801	25,984	4,724	5,669	19,882	0,472	24 x M20	361	451,9
		14,961	530307	850902								
		15,354	562022	879003								
460	18,1102	15,354	619552	971175	26,969	5,197	6,220	20,748	0,512	28 x M20	361	518,1
		15,748	656430	1002648								
		16,142	689621	1029625								

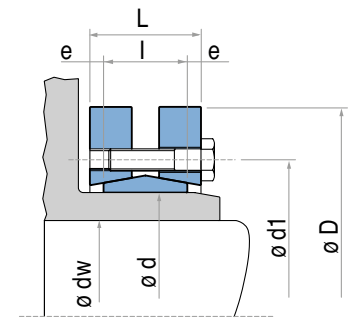

For larger diameter please contact our application engineering department.

TLK 603

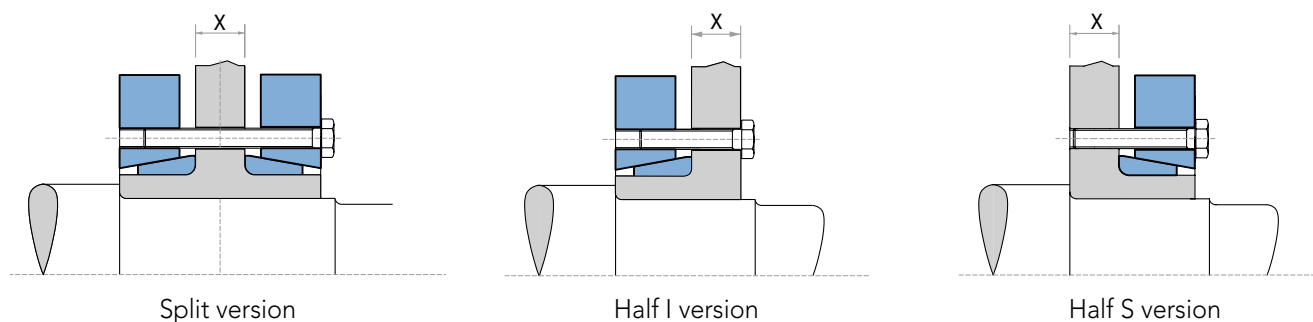

When ordering please specify X dimension

Characteristics

- Medium-high torque
- No shaft-hub axial movement
- Quick installation time
- Low inertia

Installation

Carefully clean the hub and shaft contact surfaces and apply a thin film of light-weight oil. Slide the shrink disc outside the hollow shaft. Tighten gradually and regularly in continuous sequence all screws to reach the tightening torque M_s indicated in the rating table. To reach the required tightening torque M_s it is necessary to repeat the procedure more than once.

Do not use grease with **molybdenum bisulphide** in the hub and shaft contact surfaces. Performances shown in the rating tables are calculated in the case of mounting with oil. Performances are increased when dry mounting. For any further information please contact our engineering department.

Torque capacities for half versions are = $M_t / 2$.

Dismantling

Loosen the clamping screws in a continuous and gradual sequence. Do not remove screws from threads.

Normally with this operation the shrink disc is released. In case of reuse, apply a solid lubricant (that can provide a coefficient of friction around 0.04) in the screws and in the tapered surfaces.

Tolerances, surface finish

A good surface finish by the machine tool is sufficient.

Maximum allowable surface finish:
Rt max 16 μm (Ra 3 μm - Rz 13 μm)

Maximum permissible tolerances:
d = h8 for hub o.d.

For exact tolerance values see page 57.

DW diameter tolerance

From 0.4 to 1.2 inch	H6/j6
From 1.2 to 2.0 inch	H6/h6
From 2.0 to 3.2 inch	H6/g6
From 3.2 to 19.7 inch	H7/g6

For exact tolerance values see page 57.

Axial movement

During tightening of mounting screw the hub has no axial movement with respect to the shaft.

TLK 603

Type	Customer Shaft diameter		Torque (max.)	Axial Thrust (max.)						Tightening screws DIN 931-10.9	Tightening Torque
d mm	d inch	dw inch	M _t Lb-ft	F _{ax} Lbf	D inch	l inch	L inch	d1 inch	e inch	n x type	M _t Lb-ft
24	0.945	0.787	155	6070	1.969	0.354	0.453	1.417	0.059	6 x M5*	3
30	1.181	0.984	251	6969	2.362	0.394	0.492	1.732	0.059	7 x M5*	3
36	1.417	1.181	420	13039	2.835	0.433	0.531	2.047	0.059	5 x M6	9
44	1.732	1.378	575	16636	3.150	0.492	0.591	2.402	0.098	7 x M6	9
50	1.969	1.575	856	19334	3.543	0.531	0.630	2.756	0.098	8 x M6	9
55	2.165	1.772	1121	19783	3.937	0.551	0.689	2.953	0.098	8 x M6	9
62	2.441	1.969	1623	24954	4.331	0.551	0.689	3.386	0.098	10 x M6	9
68	2.677	2.165	1844	23830	4.528	0.551	0.689	3.386	0.098	10 x M6	9
75	2.953	2.362	2360	30799	5.433	0.630	0.768	3.937	0.118	7 x M8	22
80	3.150	2.559	2876	31473	5.709	0.630	0.768	3.937	0.118	7 x M8	22
85	3.346	2.756	4499	43838	6.102	0.728	0.906	4.488	0.138	10 x M8	22
90	3.543	2.756	4425	42714	6.102	0.728	0.906	4.488	0.138	10 x M8	22
100	3.937	2.953	5532	49458	6.693	0.807	1.004	4.882	0.138	12 x M8	22
110	4.331	3.150	6638	56652	7.283	0.906	1.122	5.354	0.138	9 x M10	44
115	4.528	3.346	6786	58226	7.402	0.906	1.122	5.551	0.138	9 x M10	44
120	4.724	3.346	9810	70590	8.465	1.024	1.260	6.299	0.197	12 x M10	44
125	4.921	3.543	9588	72838	8.465	1.024	1.260	6.299	0.197	12 x M10	44
130	5.118	3.740	9810	74862	8.465	1.024	1.260	6.299	0.197	12 x M10	44
140	5.512	3.937	12981	89025	9.055	1.102	1.378	6.890	0.197	10 x M12	74
155	6.102	4.331	18439	107459	10.433	1.181	1.457	7.559	0.197	12 x M12	74
160	6.299	4.528	18955	110157	10.433	1.181	1.457	7.559	0.197	12 x M12	74
165	6.496	4.724	25815	141630	11.417	1.299	1.594	8.268	0.197	8 x M16	184
170	6.693	4.921	26552	143878	11.417	1.299	1.594	8.268	0.197	8 x M16	184
175	6.890	5.118	30240	143654	11.811	1.299	1.594	8.661	0.197	8 x M16	184
180	7.087	5.315	31125	188840	11.811	1.299	1.594	8.661	0.197	8 x M16	184
185	7.283	5.512	42041	184119	12.992	1.594	1.890	9.291	0.197	10 x M16	184
190	7.480	5.709	43295	188840	12.992	1.594	1.890	9.291	0.197	10 x M16	184
195	7.677	5.906	56055	230430	13.780	1.594	1.890	9.685	0.197	12 x M16	184
200	7.874	6.102	59005	232678	13.780	1.594	1.890	9.685	0.197	12 x M16	184
220	8.661	6.496	75231	278540	14.567	2.028	2.343	10.630	0.295	15 x M16	184
240	9.449	7.087	101783	354301	15.945	2.106	2.441	11.614	0.295	12 x M20	361
260	10.236	7.874	135711	422643	16.929	2.323	2.657	12.638	0.295	14 x M20	361
280	11.024	8.661	179965	499078	18.110	2.579	2.972	13.622	0.335	16 x M20	361
300	11.811	9.449	217580	577087	19.094	2.736	3.130	14.331	0.335	18 x M20	361
320	12.598	9.843	250770	626321	20.472	2.736	3.130	15.197	0.335	20 x M20	361
340	13.386	10.236	311619	730408	22.441	2.972	3.406	16.063	0.335	24 x M20	361
350	13.780	11.024	354029	771098	22.835	3.091	3.524	17.008	0.335	24 x M20	361
360	14.173	11.417	370255	778067	23.228	3.091	3.524	17.008	0.335	24 x M20	361
380	14.961	11.811	449912	917225	25.394	3.169	3.642	18.031	0.335	20 x M24	620
390	15.354	12.205	494903	973427	25.984	3.169	3.642	18.425	0.335	21 x M24	620
400	15.748	12.598	512604	976799	26.772	3.169	3.642	18.898	0.335	21 x M24	620
420	16.535	13.386	619550	1133042	27.165	3.720	4.193	19.842	0.394	24 x M24	620
440	17.323	13.780	634302	1103817	29.528	3.976	4.468	20.748	0.394	24 x M24	620
460	18.110	14.567	789189	1317387	30.315	3.976	4.468	21.535	0.394	28 x M24	620
480	18.898	15.354	914574	1427544	31.496	4.193	4.685	22.441	0.394	30 x M24	620

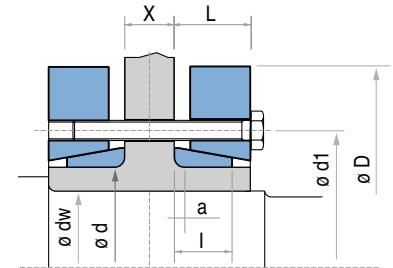

*DIN 931-8.8 screws

TLK 622

TLK 623

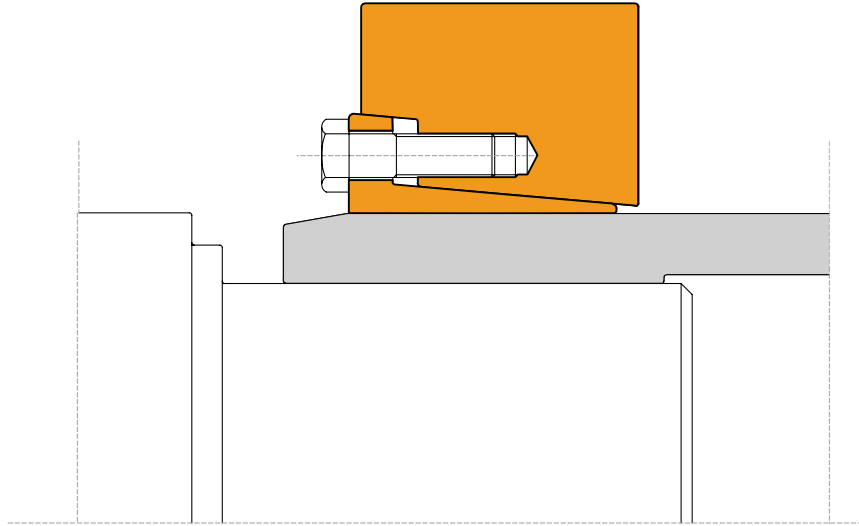

Characteristics

- Very high torques
- No shaft-hub axial movement
- Quick installation time
- Easy dismantling

Installation

Carefully clean the hub and shaft contact surfaces. Slide the shrink disc outside the hollow shaft. Tighten gradually and regularly in continuous sequence all screws to reach the tightening torque M_s indicated in the table. To reach the required tightening torque M_s it is necessary to repeat the procedure more than once.

Do not use grease with **molybdenum bisulphide** in the hub and shaft contact surfaces.

Dismantling

Loosen the clamping screws in a continuous and gradual sequence. Do not remove screws from threads. Normally with this operation the shrink disc is released. In case of reuse, apply a solid lubricant (that can provide a coefficient of friction around 0.04) in the screws and in the tapered surfaces.

Tolerances, surface finish

A good surface finish by the machine tool is sufficient. Maximum allowable surface finish:
Rt max 16 μm (Ra 3 μm - Rz 13 μm)

Maximum permissible tolerances:
d = h7 for hub o.d.

For exact tolerance values see page 57.

DW diameter tolerance

dw: up to 5.9 inch	H7/h6
over 5.9 inch	H7/g6

For exact tolerance values see page 57.

Axial movement

During tightening of mounting screw the hub has no axial movement with respect to the shaft.

TLK 622 / TLK 681

Type	Shaft diameter			TLK622			TLK681			Dimensions					Tightening screws DIN 931	Weight
	d mm	d inch	dw inch	M _t Lb-ft	F _{ax} Lbf	Ms Lb-ft	M _t Lb-ft	F _{ax} Lbf	Ms Lb-ft	D inch	l inch	L inch	d1 inch	e inch		
12	0,4724	0,354	15	1124	9					1,496	0,394	0,433	0,945	0,039	M6	0,1
		0,394	30	1798												
14	0,5512	0,433	22	1349	9					1,496	0,394	0,433	1,024	0,039	M6	0,1
		0,472	37	2023												
16	0,6299	0,512	52	2248	9					1,614	0,531	0,591	1,102	0,059	M6	0,1
		0,551	66	2923												
18	0,7087	0,591	59	2473	9					1,732	0,531	0,591	1,181	0,059	M6	0,1
		0,630	81	3147												
20	0,7874	0,669	111	4047	9					1,850	0,531	0,591	1,260	0,059	M6	0,1
		0,709	133	4496												
24	0,9449	0,748	118	3822	9					1,969	0,630	0,709	1,417	0,079	M6	0,2
		0,787	155	4496												
30	1,1811	0,945	199	5171	9					2,362	0,709	0,787	1,732	0,079	M6	0,3
		0,984	236	5620												
36	1,4173	1,063	325	7194	22					2,835	0,787	0,866	2,047	0,079	M8	0,5
		1,024	266	6295												
44	1,7323	1,181	450	9217	22					3,150	0,866	0,945	2,402	0,079	M8	0,6
		1,299	605	11240												
50	1,9685	1,339	509	9217	22					3,543	0,925	1,024	2,677	0,098	M8	0,8
		1,378	568	9892												
55	2,1654	1,457	679	11240	22					3,937	1,024	1,142	2,835	0,118	M8	1,1
		1,496	819	13039												
62	2,4409	1,575	951	14613	22					4,331	1,024	1,142	3,150	0,118	M8	1,3
		1,654	1114	15961												
68	2,6772	1,654	907	13264	22					4,528	1,024	1,142	3,386	0,118	M8	1,3
		1,890	1232	15737												
75	2,9528	1,969	1379	16861	44					5,433	1,063	1,220	3,937	0,157	M10	2,3
		2,047	1564	18210												
80	3,1496	2,165	1807	20008	44					5,551	1,063	1,220	4,094	0,157	M10	2,3
		2,362	2301	23380												
90	3,5433	2,165	1719	19109	44					6,102	1,339	1,496	4,488	0,157	M10	3,2
		2,559	2810	26303												
100	3,9370	2,362	2353	23830	44					6,693	1,535	1,693	4,882	0,157	M10	4,3
		2,559	2995	27652												
110	4,3307	2,756	3621	31473	74					7,283	1,713	1,929	5,433	0,217	M12	5,8
		2,953	5753	46760												
120	4,7244	2,756	4425	38442	74					7,756	1,831	2,087	5,787	0,256	M12	6,9
		2,953	5310	43163												
125	4,9213	3,150	6269	47884	74					8,465	1,831	2,087	5,984	0,256	M12	8,7
		3,346	8629	61822												
135	5,3150	3,346	8777	62947	118					9,055	1,949	2,283	6,496	0,335	M14	11,0
		3,543	10621	71714												
140	5,5118	3,740	11727	75086	118					9,055	1,949	2,283	6,693	0,335	M14	10,0
		3,937	13792	84303												
155	6,1024	3,740	13350	85877	118					10,354	2,106	2,441	7,244	0,335	M14	15,0
		4,134	16300	94645												
		4,528	20357	108133												
		4,331	19545	108358												
		4,528	21758	115552												
		4,921	26626	129940												

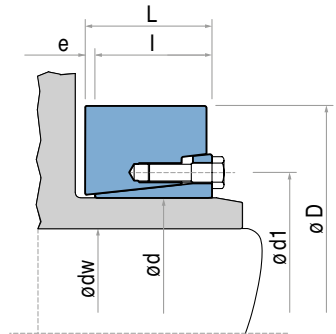

For larger diameter please contact our application engineering department.

TLK 622 / TLK 681

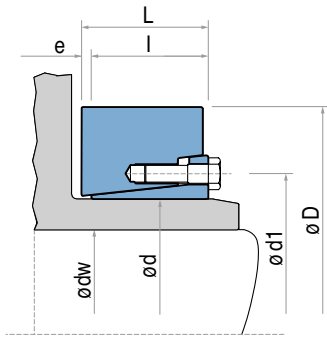

Type	Shaft diameter	TLK622			TLK681			Dimensions					Tightening screws DIN 931	Weight	
		Torque	Axial force	Tightening torque	Torque	Axial force	Tightening torque	D	l	L	d1	e			
d mm	d inch	d _w inch	M _t Lb-ft	F _{ax} Lbf	M _s Lb-ft	M _t Lb-ft	F _{ax} Lbf	M _s Lb-ft	D inch	l inch	L inch	d1 inch	e inch	Type	Lb
165	6,4961	4,724	27511	139831	184	32453	165010	221	11,417	2,283	2,677	7,795	0,394	M16	22,0
		4,921	30388	148149		35772	174452								
		5,315	36583	165010		42852	193336								
175	6,8898	5,118	33190	155568	184	39828	187491	221	11,811	2,283	2,677	8,189	0,394	M16	23,0
		5,315	36141	164111		43516	196933								
		5,709	42779	180971		51629	216266								
185	7,2835	5,512	47204	205925	184	59743	260104	221	12,598	2,953	3,346	8,740	0,394	M16	33,0
		5,709	51629	216041		64905	272019								
		6,102	60480	236724		75231	296523								
200	7,8740	5,906	59743	241220	184	70806	287531	221	13,386	2,953	3,346	9,370	0,394	M16	36,0
		6,102	64168	251786		75969	299670								
		6,496	73756	273368		87770	324174								
220	8,6614	6,299	75969	288430	361	95146	363066	420	14,567	3,583	4,055	10,551	0,472	M20	53,0
		6,693	87770	313608		109897	393191								
		7,087	100308	339237		124648	423315								
240	9,4488	6,693	89983	323500	361	111372	398586	420	15,945	3,701	4,213	11,339	0,512	M20	66,0
		7,087	103259	349578		126861	429160								
		7,874	132024	402408		160789	490758								
260	10,2362	7,480	120223	385547	361	156363	501549	420	16,929	4,134	4,685	12,283	0,551	M20	82,0
		7,874	135711	414098		175540	536169								
		8,661	170377	471874		219056	606085								
280	11,0236	8,268	158576	461083	361	205780	598217	420	18,110	4,567	5,197	13,150	0,630	M20	103,0
		8,661	177015	491432		229382	635085								
		9,449	217581	552580		279536	709497								
300	11,8110	8,661	199142	552131	620	244871	678473	723	19,094	4,882	5,512	14,173	0,630	M24	120,0
		9,055	221269	585627		270685	717815								
		9,843	267735	653295		326740	796948								
320	12,5984	9,449	222006	564495	620	297975	757606	723	20,472	4,882	5,512	14,961	0,630	M24	138,0
		9,843	244871	596868		327478	797847								
		10,630	293550	662062		389433	879228								
340	13,3858	9,843	287649	700954	620	359930	877879	723	22,441	5,394	6,102	15,827	0,709	M24	189,0
		10,236	314939	738048		393121	921941								
		11,024	373206	813134		464664	1011191								
350	13,7795	10,630	363618	820328	620	454338	1025803	723	22,835	5,591	6,378	16,299	0,787	M24	202,0
		11,024	394596	859894		493429	1074137								
		11,417	427786	899461		534733	1124045								
360	14,1732	10,630	365831	826398	620	460976	1040416	723	23,228	5,591	6,378	16,693	0,787	M24	207,0
		11,024	397546	865964		499330	1087850								
		11,811	465402	945546		582674	1183394								
380	14,9606	11,417	431474	906879	922	534733	1124045	1069	25,197	5,748	6,535	17,874	0,787	M27	244,0
		11,811	466139	947570		577511	1173503								
		12,205	502280	988485		622502	1224085								
390	15,3543	11,417	472040	991632	922	576036	1210371	1069	25,591	5,748	6,535	17,874	0,787	M27	249,0
		11,811	509655	1035245		621027	1261403								
		12,598	589312	1123145		716173	1364365								
420	16,5354	12,598	547271	1043113	922	714698	1361668	1069	26,378	6,535	7,323	19,134	0,787	M27	285,0
		12,992	587837	1085602		765589	1414048								
		13,780	672657	1171030		872536	1519259								
440	17,3228	13,386	696996	1249263	922	893925	1602438	1069	28,346	6,850	7,638	19,921	0,787	M27	357,0
		13,780	744200	1295799		952930	1659540								
		14,567	843034	1389544		1076841	1773967								
460	18,1102	14,173	814269	1378753	922	1027424	1739796	1069	30,315	6,850	7,638	21,024	0,787	M27	419,0
		14,567	865898	1426413		1090854	1797348								
		15,354	973582	1522181		1224353	1913349								
480	18,8976	14,961	958831	1538368	1210	1222140	1960559	1453	31,496	7,520	8,386	21,732	0,866	M30	492,0
		15,354	1016361	1588500		1293684	2021707								
		16,142	1136583	1689664		1442672	2145127								
500	19,6850	15,748	1103393	1681121	1210	1391780	2121072	1453	33,465	7,520	8,386	22,520	0,866	M30	567,0
		16,142	1166086	1733502		1469224	2184469								
		16,929	1297372	1838937		1630750	2311710								
530	20,8661	16,929	1423495	2017885	1210	1767936	2506620	1453	35,827	8,504	9,370	23,858	0,866	M30	744,0
		17,323	1497989	2075886		1859394	2576086								
		18,110	1654352	2192337		2048948	2715242								
560	22,0472	17,717	1546668	2094770	1210	1877096	2543264	1453	37,008	8,504	9,370	24,882	0,866	M30	776,0
		18,110	1623374	2151871		1970028	2610257								
		18,898	1784900	2266299		2161057	2744917								
590	23,2283	18,504	1912499	2480092	1210	2189822	2840686	1453	37,795	9,252	10,236	26,142	0,984	M30	835,0
		18,898	2002481	2543488		2292343	2911725								
		19,685	2190559	2670955		2505499	3054479								
620	24,4094	19,685	2141880	2611381	1210	2509186	3059200	1453	40,157	10,276	11,260	27,795	0,984	M30	1064,0
		20,472	2337334	2740421		2734880	3206000								
		21,260	2542377	2870136		2970900	3353700								

For larger diameter please contact our application engineering department.

TLK 623/ TLK 683

Type	d	d	Shaft diameter	TLK623			TLK683			Dimensions					Tightening screws DIN 931	Weight	
				Torque	Axial force	Tightening torque	Torque	Axial force	Tightening torque	D	I	L	d1	e			
	mm	inch	dw	M _s	F _{ax}	M _s	M _s	F _{ax}	M _s	D	I	L	d1	e	Type	Lb	
			inch	Lb-ft	Lbf	Lb-ft	Lb-ft	Lbf	Lb-ft	inch	inch	inch	inch	inch			
140	5,5118	3,937	19177	117575		22127	136459										
		4,134	22127	126343	184	25077	146126										
		4,528	27290	144103		30978	165684		221	9,055	2,520	2,913	6,850	0,394	M16	28,7	
155	6,1024	4,331	26552	145227		33190	182095										
		4,528	29502	154444	184	36141	193336										
		4,921	35403	173553		44254	215592		221	10,354	2,756	3,150	7,638	0,394	M16	41,9	
165	6,4961	4,724	36878	186142		46466	235375										
		4,921	40566	197157	184	50892	248414										
		5,315	48679	219638		61218	274941		221	11,417	3,031	3,465	8,031	0,433	M16	57,3	
175	6,8898	5,118	44991	211995		53842	252011										
		5,315	49417	223235	184	59005	264825										
		5,709	58267	245941		69331	290453		221	11,811	3,031	3,465	8,425	0,433	M16	59,5	
185	7,2835	5,512	65643	285283		78182	339911										
		5,709	70806	298996	361	84820	355648										
		6,102	83345	327097		98833	387346		420	12,598	3,937	4,409	9,134	0,472	M20	88,2	
200	7,8740	5,906	76706	312709		92933	378803										
		6,102	83345	326647	361	100308	394989										
		6,496	95883	354524		115797	427137		420	13,386	3,937	4,409	9,685	0,472	M20	97,0	
220	8,6614	6,299	39670	357671		119485	455688										
		6,496	101046	373408	361	128336	474796										
		7,087	124648	421742		157101	531898		420	14,567	4,764	5,276	10,472	0,512	M20	141,1	
240	9,4488	6,693	115797	415222		151938	544937										
		7,087	132761	448719	361	173327	586077										
		7,874	169639	517061		219794	669481		420	15,945	5,118	5,669	11,260	0,551	M20	178,6	
260	10,2362	7,480	169639	544937		210205	674427										
		7,874	191766	584503	361	236757	720962										
		8,661	239708	664760		294287	814483		420	16,929	5,669	6,299	12,047	0,630	M20	224,9	
280	11,0236	8,268	225694	655992		266260	772219										
		8,661	252246	698032	620	295762	819653										
		9,449	308301	783459		360668	915872		723	18,110	6,142	6,772	13,150	0,630	M24	277,8	
300	11,8110	9,055	265522	704102		340016	901484										
		9,449	293550	745017	620	374682	950942										
		9,843	322315	786382		410085	1000849		723	19,094	6,220	6,929	13,937	0,709	M24	310,9	
320	12,5984	9,449	317152	804816		377632	959709										
		9,843	348867	850003	620	414510	1011191										
		10,630	416723	941050		494167	1115052		723	20,472	6,535	7,244	14,724	0,709	M24	377,0	
340	13,3858	9,843	406397	990733		487529	1188790										
		10,236	444750	1042439	922	532520	1248139										
		11,024	526619	1146526		628403	1368187		1069	22,441	7,323	8,110	15,906	0,787	M27	518,1	
360	14,1732	10,630	494904	1117076		562760	1271070										
		11,024	537683	1169906	922	610701	1329520										
		11,811	628403	1276690		712485	1447320		1069	23,228	7,402	8,268	16,693	0,866	M27	553,4	
390	15,3543	11,417	626928	1317380		721336	1515887										
		11,811	676344	1374931	922	777390	1580182										
		12,598	782553	1491158		897613	1709897		1069	25,591	7,717	8,661	17,953	0,945	M27	714,3	
420	16,5354	12,598	742725	1414947		956618	1822301										
		12,992	796567	1471824	922	1024474	1891992										
		13,780	910889	1586702		1166823	2032273		1069	27,165	8,701	9,685	19,134	0,984	M27	901,7	
440	17,3228	13,386	898351	1610981		1167561	2093421										
		13,780	959568	1671005	1210	1244267	2167608										
		14,567	1087904	1792177		1406531	2316881		1453	29,528	9,173	10,157	20,236	0,984	M30	1159,6	
460	18,1102	14,173	1034062	1751486		1278933	2165360										
		14,567	1099705	1812410	1210	1357852	2237523										
		15,354	1237629	1934706		1524541	2382750		1453	30,315	9,173	10,157	21,024	0,984	M30	1199,3	
480	18,8976	14,961	1259019	2019684		1531179	2456263										
		15,354	1334250	2085553	1210	1621162	2533597										
		16,142	1492088	2218190		1808502	2688940		1453	31,496	10,630	11,732	21,732	1,102	M30	1415,4	
500	19,6850	15,748	1469961	2239772		1865295	2842709										
		16,142	1553306	2309462	1210	1968553	2927237										
		16,929	1727370	2449293		2184659	3097193		1453	33,465	10,630	11,811	22,520	1,181	M30	1633,6	
530	20,8661	16,929	1880046	2665560		2281280	3233877										
		17,323	1978879	2741770	1630	2398552	3323126										
		18,110	2184659	2895090		2643423	3502748		1955	35,039	12,047	13,307	24,252	1,260	M33	1982,0	
560	22,0472	17,717	2092464	2834616		2536476	3435980										
		18,110	2196460	2911276	1630	2660387	3525679										
		18,898	2413303	3065045		2917796	3705975		1955	37,008	12,047	13,307	25,433	1,260	M33	2204,6	

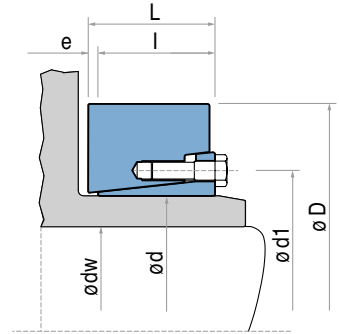

For larger diameter please contact our application engineering department.

Calculation of minimum hub diameter DM

By installing TOLLOK locking assemblies the surface pressure P_h , is exerted along the shaft and hub mating surfaces. The effect of this pressure must be considered in choosing appropriate hub material and minimum hub

thickness. Below information is provided to assist you in calculating the minimum hub diameter DM for following three application types. Factor C is based on application type.

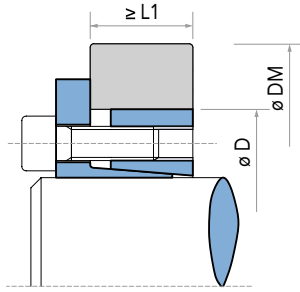

C=1

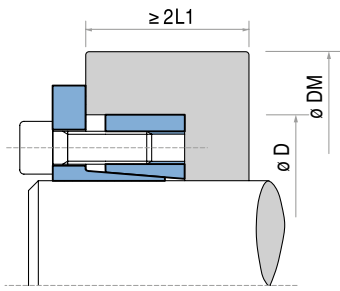
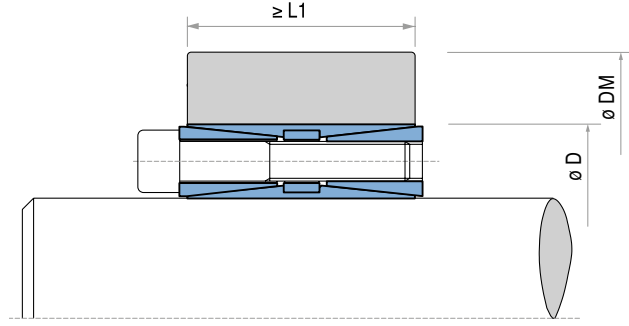

C=0,8

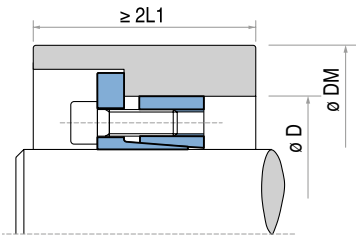
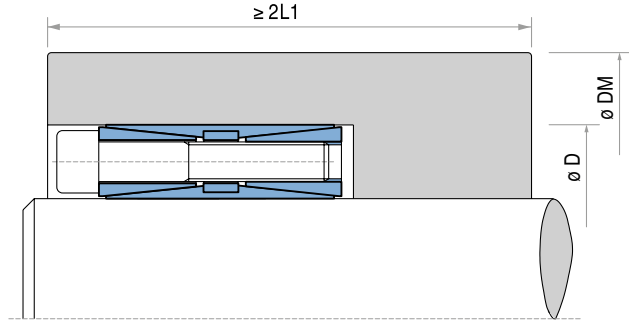

C=0,6

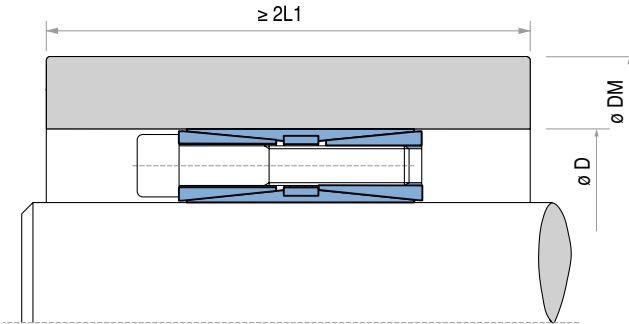

For minimum hub diameter DM calculation following formula must be applied:

$$DM \geq D \cdot K$$

where K is equal to:
$$K = \sqrt{\frac{\sigma_{02} + (C \cdot P_h)}{\sigma_{02} - (C \cdot P_h)}}$$

See page 53 for K values of selected hub materials.

Example:

Locking Assembly type TOLLOK TLK 131 \times 2 7/16 x 3.740.
Hub pressure $P_h = 11346$ psi (see table page 15).

Hub material 1045 Annealed (yield strength: $\sigma_{02} = 50000$ psi)
Hub length and shape equivalent $C = 1$.

$$DM \geq 3.740 \cdot 1.26 \geq 4.712 \text{ inch}$$

Common Material

- Yield Strength (psi)
- 1045 Annealed - 50000
- 4150 Hardened - 120000
- Ductile Iron, Ferrite - 40000
- Inconel 600 - 35000
- Aluminum 356 Cast - 22000

Calculation of minimum hub diameter DM

TABLE OF COEFFICIENT K

P _h psi	Application type C	Yield point [psi]										
		21756	26107	29008	31908	36259	39160	43511	50763	58015	65267	87023
		K										
8702	C = 0.6	1.28	1.25	1.20	1.18	1.15	1.14	1.12	1.10	1.09	1.08	1.06
	C = 0.8	1.39	1.30	1.24	1.23	1.22	1.20	1.18	1.15	1.12	1.11	1.08
	C = 1.0	1.52	1.42	1.36	1.32	1.28	1.25	1.22	1.18	1.16	1.14	1.10
9427	C = 0.6	1.30	1.25	1.22	1.20	1.18	1.15	1.13	1.11	1.10	1.09	1.07
	C = 0.8	1.44	1.35	1.30	1.28	1.24	1.22	1.20	1.16	1.14	1.12	1.09
	C = 1.0	1.60	1.45	1.40	1.35	1.30	1.28	1.24	1.20	1.18	1.16	1.12
10153	C = 0.6	1.34	1.26	1.24	1.22	1.18	1.16	1.15	1.12	1.11	1.10	1.07
	C = 0.8	1.48	1.38	1.34	1.30	1.25	1.23	1.20	1.18	1.15	1.13	1.10
	C = 1.0	1.65	1.50	1.45	1.40	1.34	1.30	1.26	1.22	1.20	1.17	1.13
10878	C = 0.6	1.30	1.28	1.25	1.23	1.20	1.18	1.16	1.14	1.12	1.11	1.08
	C = 0.8	1.52	1.42	1.36	1.32	1.28	1.25	1.22	1.18	1.16	1.14	1.11
	C = 1.0	1.74	1.55	1.48	1.42	1.36	1.33	1.30	1.25	1.20	1.18	1.13
11603	C = 0.6	1.39	1.31	1.28	1.25	1.21	1.20	1.18	1.15	1.13	1.11	1.08
	C = 0.8	1.58	1.45	1.39	1.35	1.30	1.27	1.24	1.20	1.18	1.15	1.11
	C = 1.0	1.81	1.61	1.53	1.46	1.39	1.36	1.31	1.26	1.22	1.20	1.14
12328	C = 0.6	1.42	1.34	1.30	1.27	1.23	1.21	1.19	1.16	1.14	1.12	1.09
	C = 0.8	1.63	1.49	1.42	1.38	1.32	1.29	1.26	1.22	1.19	1.16	1.12
	C = 1.0	1.90	1.67	1.57	1.50	1.42	1.39	1.34	1.28	1.24	1.21	1.15
13053	C = 0.6	1.46	1.36	1.32	1.28	1.25	1.22	1.20	1.17	1.15	1.13	1.09
	C = 0.8	1.69	1.53	1.46	1.40	1.34	1.31	1.28	1.23	1.20	1.18	1.13
	C = 1.0	2.00	1.73	1.62	1.54	1.46	1.41	1.36	1.30	1.26	1.22	1.16
13779	C = 0.6	1.49	1.39	1.34	1.30	1.26	1.24	1.21	1.18	1.15	1.14	1.10
	C = 0.8	1.75	1.57	1.49	1.43	1.37	1.34	1.30	1.25	1.21	1.19	1.14
	C = 1.0	2.11	1.80	1.68	1.59	1.49	1.44	1.39	1.32	1.27	1.24	1.17
14504	C = 0.6	1.53	1.41	1.36	1.32	1.28	1.25	1.22	1.19	1.16	1.14	1.11
	C = 0.8	1.81	1.61	1.53	1.46	1.39	1.36	1.31	1.26	1.22	1.20	1.14
	C = 1.0	2.24	1.87	1.73	1.63	1.53	1.48	1.41	1.34	1.29	1.25	1.18
15229	C = 0.6	1.56	1.44	1.39	1.34	1.29	1.27	1.24	1.20	1.17	1.15	1.11
	C = 0.8	1.88	1.66	1.56	1.50	1.42	1.38	1.33	1.28	1.24	1.21	1.15
	C = 1.0	2.38	1.95	1.79	1.68	1.56	1.51	1.44	1.36	1.31	1.27	1.19
15954	C = 0.6	1.60	1.47	1.41	1.36	1.31	1.28	1.25	1.21	1.18	1.16	1.12
	C = 0.8	1.96	1.71	1.60	1.53	1.44	1.41	1.35	1.29	1.25	1.22	1.16
	C = 1.0	2.55	2.04	1.86	1.73	1.60	1.54	1.47	1.38	1.33	1.28	1.20
16679	C = 0.6	1.64	1.50	1.43	1.36	1.33	1.30	1.26	1.22	1.19	1.17	1.12
	C = 0.8	2.04	1.76	1.64	1.56	1.47	1.43	1.37	1.31	1.26	1.23	1.17
	C = 1.0	2.75	2.13	1.93	1.79	1.64	1.58	1.50	1.41	1.34	1.30	1.21
17405	C = 0.6	1.69	1.53	1.46	1.40	1.34	1.31	1.28	1.23	1.20	1.18	1.13
	C = 0.8	2.13	1.81	1.69	1.60	1.50	1.45	1.39	1.33	1.28	1.24	1.18
	C = 1.0	3.00	2.24	2.00	1.84	1.69	1.61	1.53	1.43	1.36	1.31	1.22
18130	C = 0.6	1.73	1.56	1.48	1.43	1.36	1.33	1.29	1.24	1.21	1.18	1.13
	C = 0.8	2.24	1.87	1.73	1.63	1.53	1.48	1.41	1.34	1.29	1.25	1.18
	C = 1.0	3.32	2.35	2.08	1.91	1.73	1.65	1.56	1.45	1.38	1.33	1.24
18855	C = 0.6	1.78	1.59	1.51	1.45	1.38	1.35	1.30	1.25	1.22	1.19	1.14
	C = 0.8	2.35	1.93	1.78	1.67	1.56	1.50	1.44	1.36	1.30	1.27	1.19
	C = 1.0	3.74	2.49	2.17	1.97	1.78	1.69	1.59	1.48	1.40	1.35	1.25
19580	C = 0.6	1.83	1.62	1.54	1.47	1.40	1.36	1.32	1.27	1.23	1.20	1.15
	C = 0.8	2.48	2.00	1.83	1.71	1.59	1.53	1.46	1.38	1.32	1.28	1.20
	C = 1.0	4.36	2.65	2.27	2.04	1.83	1.73	1.62	1.50	1.42	1.36	1.26
20305	C = 0.6	1.88	1.66	1.56	1.50	1.42	1.38	1.33	1.28	1.24	1.21	1.15
	C = 0.8	2.63	2.07	1.88	1.75	1.62	1.55	1.48	1.39	1.33	1.29	1.21
	C = 1.0	5.39	2.83	2.38	2.12	1.88	1.78	1.66	1.53	1.44	1.38	1.27
21030	C = 0.6	1.94	1.69	1.59	1.52	1.44	1.40	1.35	1.29	1.25	1.22	1.16
	C = 0.8	2.80	2.15	1.94	1.80	1.65	1.58	1.50	1.41	1.35	1.30	1.22
	C = 1.0	7.68	3.05	2.50	2.21	1.94	1.82	1.69	1.55	1.46	1.40	1.28
21756	C = 0.6	2.00	1.73	1.62	1.54	1.46	1.41	1.36	1.30	1.26	1.23	1.16
	C = 0.8	3.00	2.24	2.00	1.84	1.69	1.61	1.53	1.43	1.36	1.31	1.23
	C = 1.0	—	3.32	2.65	2.30	2.00	1.87	1.73	1.58	1.48	1.41	1.29
22481	C = 0.6	2.06	1.77	1.65	1.57	1.48	1.43	1.38	1.31	1.27	1.24	1.17
	C = 0.8	3.25	2.33	2.06	1.89	1.72	1.65	1.55	1.45	1.38	1.33	1.23
	C = 1.0	—	3.66	2.80	2.40	2.06	1.92	1.77	1.61	1.51	1.43	1.30
23206	C = 0.6	2.13	1.81	1.69	1.60	1.50	1.45	1.39	1.33	1.28	1.24	1.18
	C = 0.8	3.55	2.43	2.13	1.94	1.76	1.67	1.58	1.47	1.39	1.34	1.24
	C = 1.0	—	4.12	3.00	2.52	2.13	1.98	1.81	1.64	1.53	1.45	1.31
23931	C = 0.6	2.21	1.86	1.72	1.62	1.52	1.47	1.41	1.34	1.29	1.25	1.18
	C = 0.8	3.96	2.55	2.21	2.00	1.80	1.71	1.60	1.49	1.41	1.35	1.25
	C = 1.0	—	4.80	3.23	2.65	2.21	2.04	1.86	1.67	1.55	1.47	1.33

Nomenclature

M_t	Lb-ft	Transmissible torque	K		Application factor for DM calculation
F_{ax}	Lbf	Permissible axial thrust	C		Variable coefficient depending on hub length and shape.
d	inch/mm	Shaft diameter	dg	mm	Screws diameter
D	inch/mm	Clamping unit outside diameter	Sf	inch	Flange thickness
L1, L2, L3, B	Inch	Clamping unit lengths	w	inch	Distance between flange and hub before tightening
M_s	Lb-ft	Screws tightening torque	i	inch	Bolt circle diameter
P_v	Lbf	Screws axial thrust	Pt	Lbf	Pre-load force necessary to compensate the clearance between shaft/TLK300/ hub for non-split elements
P_s	psi	Surface pressure on shaft	Rt	RMS	Surface finish
P_h	psi	Surface pressure on hub			
Pa	Lbf	Total thrust force necessary to transmit the required torque			
n x type		Number of bolts x bolt dia.			
DM	Inch/mm	Hub minimum diameter			
σ02	psi	Yield point of hub material			

Basic Formulas

- Calculate Torque based on horsepower (HP) and speed (RPM):

$$\text{Torque (M)} = \frac{5252 \times \text{HP}}{\text{RPM}} \quad (\text{Lb-ft})$$

- Calculate Torque transmitted based on shaft diameter (d), axial or thrust load (Axial Force), maximum or peak torque (M):

$$\text{Torque Transmitted (M}_{\text{tran}}) = \sqrt{M^2 + \left[\frac{\text{Axial Force} \times d}{24} \right]^2} \quad (\text{Lb-ft})$$

M = Maximum or peak torque (Lb-ft)
 Axial Force = Axial or thrust load (Lbf)
 d = shaft diameter (inch)

Note: **M_{tran}** value should never exceed the **M_t** value shown in the rating table of the selected unit. For assistance in selecting correct Tollok locking assemblies, rigid couplings or shrink-discs, contact our application engineering department at **866-REXNORD/866-739-6673**.

- To determine the minimum hub outside diameter (DM), follow the instructions shown on page 50.

- If bending moments are present in your application please contact our application engineering department. Typical applications like conveyor pulleys and roller conveyors where the effect of bending moments must be considered in sizing the correct Tollok product.

Unit Conversion

1 mm =	0.03937 in
1 Nm =	8.85 Lb-in
1 Nm =	0.738 Lb-ft
1 Lb-ft =	12 Lb-in
1 KN =	224.82 Lbf
1 N/mm ² =	145.04 psi
1 HP =	0.746 kW

TOLERANCE CHARTS

Hub Diameter (inch)		0.118	0.236	0.394	0.709	1.181	1.969	3.150	4.724	7.087	9.843	12.402	15.748	19.685	24.803	31.496
Over	Including	0.236	0.394	0.709	1.181	1.969	3.150	4.724	7.087	9.843	12.402	15.748	19.685	24.803	31.496	39.370

Hub Diameter (mm)		3	6	10	18	30	50	80	120	180	250	315	400	500	630	800
Over	Including	6	10	18	30	50	80	120	180	250	315	400	500	630	800	1000
H6 [0.0]	inch	+0.0003	+0.0004	+0.0004	+0.0005	+0.001	+0.001	+0.001	+0.001	+0.001	+0.001	+0.001	+0.002	+0.002	+0.002	+0.002
	mm	+0.01	+0.01	+0.01	+0.01	+0.02	+0.02	+0.02	+0.03	+0.03	+0.03	+0.04	+0.04	+0.04	+0.05	+0.06
H7 [0.0]	inch	+0.001	+0.001	+0.001	+0.001	+0.001	+0.001	+0.001	+0.002	+0.002	+0.002	+0.002	+0.003	+0.003	+0.003	+0.004
	mm	+0.01	+0.02	+0.02	+0.02	+0.03	+0.03	+0.04	+0.04	+0.05	+0.05	+0.06	+0.06	+0.07	+0.08	+0.09
H8 [0.0]	inch	+0.001	+0.001	+0.001	+0.001	+0.002	+0.002	+0.002	+0.002	+0.003	+0.003	+0.004	+0.004	+0.004	+0.005	+0.006
	mm	+0.02	+0.02	+0.03	+0.03	+0.04	+0.05	+0.05	+0.06	+0.07	+0.08	+0.09	+0.10	+0.11	+0.13	+0.14
H11 [0.0]	inch	+0.003	+0.004	+0.004	+0.005	+0.006	+0.007	+0.009	+0.010	+0.011	+0.013	+0.014	+0.016	+0.017	+0.020	+0.022
	mm	+0.08	+0.09	+0.11	+0.13	+0.16	+0.19	+0.22	+0.25	+0.29	+0.32	+0.36	+0.40	+0.44	+0.50	+0.56

Shaft Diameter (inch)		0.118	0.236	0.394	0.709	1.181	1.969	3.150	4.724	7.087	9.843	12.402	15.748	19.685	24.803	31.496
Over	Including	0.236	0.394	0.709	1.181	1.969	3.150	4.724	7.087	9.843	12.402	15.748	19.685	24.803	31.496	39.370

Shaft Diameter (mm)		3	6	10	18	30	50	80	120	180	250	315	400	500	630	800
Over	Including	6	10	18	30	50	80	120	180	250	315	400	500	630	800	1000
f7	inch	-0.0004	-0.0005	-0.0006	-0.0008	-0.0010	-0.0012	-0.0014	-0.002	-0.002	-0.002	-0.002	-0.003	-0.003	-0.003	-0.004
		-0.001	-0.001	-0.001	-0.002	-0.002	-0.002	-0.003	-0.003	-0.004	-0.004	-0.005	-0.005	-0.006	-0.006	-0.007
	mm	-0.010	-0.01	-0.02	-0.02	-0.03	-0.03	-0.04	-0.04	-0.05	-0.06	-0.06	-0.07	-0.08	-0.09	-0.10
g6	inch	-0.0002	-0.0002	-0.0002	-0.0003	-0.0004	-0.0004	-0.0005	-0.001	-0.001	-0.001	-0.001	-0.001	-0.001	-0.001	-0.001
		-0.001	-0.001	-0.001	-0.001	-0.001	-0.001	-0.001	-0.002	-0.002	-0.002	-0.002	-0.002	-0.003	-0.003	-0.003
	mm	-0.004	-0.01	-0.01	-0.01	-0.01	-0.01	-0.01	-0.01	-0.02	-0.02	-0.02	-0.02	-0.02	-0.02	-0.03
h6 [+0.0]	inch	-0.0003	-0.0004	-0.0004	-0.0005	-0.001	-0.001	-0.001	-0.001	-0.001	-0.001	-0.001	-0.002	-0.002	-0.002	-0.002
	mm	-0.01	-0.01	-0.01	-0.01	-0.02	-0.02	-0.02	-0.03	-0.03	-0.03	-0.04	-0.04	-0.04	-0.05	-0.06
h8 [+0.0]	inch	-0.001	-0.001	-0.001	-0.001	-0.002	-0.002	-0.002	-0.002	-0.003	-0.003	-0.004	-0.004	-0.004	-0.004	-0.005
	mm	-0.02	-0.02	-0.03	-0.03	-0.04	-0.05	-0.05	-0.06	-0.07	-0.08	-0.09	-0.10	-0.11	-0.13	-0.14
h611 [+0.0]	inch	-0.003	-0.004	-0.004	-0.005	-0.006	-0.007	-0.009	-0.010	-0.011	-0.013	-0.014	-0.016	-0.017	-0.020	-0.022
	mm	-0.08	-0.09	-0.11	-0.13	-0.16	-0.19	-0.22	-0.25	-0.29	-0.32	-0.36	-0.40	-0.44	-0.50	-0.56
j6	inch	+0.0002	+0.0003	+0.0003	+0.0004	+0.0004	+0.0005	+0.0005	+0.0006	+0.001	+0.001	+0.001	+0.001			
		-0.0001	-0.0001	-0.0001	-0.0002	-0.0002	-0.0003	-0.0004	-0.0004	-0.001	-0.001	-0.001	-0.001			
	mm	+0.01	+0.01	+0.01	+0.01	+0.01	+0.01	+0.01	+0.01	+0.02	+0.02	+0.02	+0.02			
		-0.002	-0.002	-0.003	-0.004	-0.01	-0.01	-0.01	-0.01	-0.01	-0.02	-0.02	-0.02			

Assembly and Disassembly Instruction

CAUTION: With assembly and disassembly of the locking assemblies, rigid coupling or shrink disc, it has to be made sure that the entire drive train is secured and protected against unintentional engagement. Serious bodily injury may occur from rotating parts.

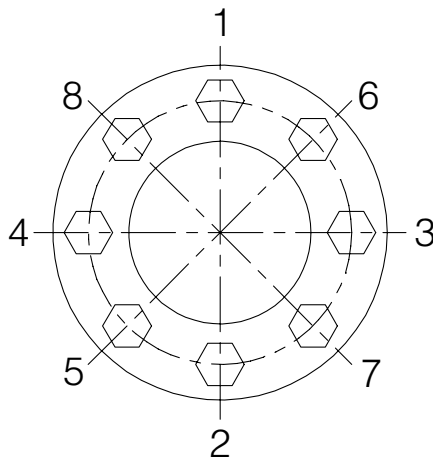

Figure 1

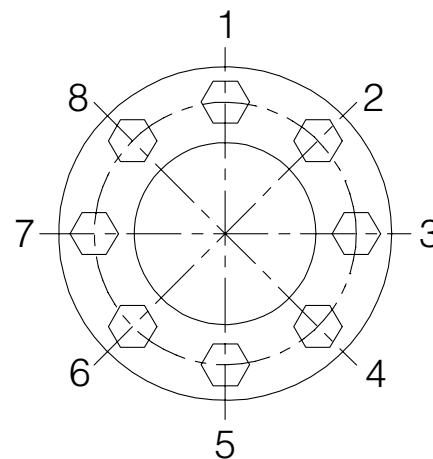

Figure 2

Figure 1 and 2 are examples of the typical tightening screw layouts. For exact number of screws refer to the appropriate Tollok unit rating table.

Assembly Instruction

- 1 Carefully clean the hub and shaft contact surfaces and apply a thin film of light-weight oil.
- 2 Slide the clamping unit into the hub bore and on to the shaft
- 3 Tighten clamping screws gradually in the cross sequence shown in Figure-1
- 4 During the first round of tightening all clamping screws, apply up to 50% of the tightening torque M_s indicated in the appropriate rating table.
- 5 Repeat above steps 3 and 4, however, this time apply 100% of the tightening torque M_s indicated in the appropriate rating table.
- 6 Apply 100% of the tightening torque M_s in continuous sequence as shown in Figure-2. Perform this step maximum twice.

Note:

- 1 Do not use any oil with Molybdenum Bisulphide, high pressure additives, or grease. These substances notably reduce the coefficient of friction.
- 2 Do not use impact wrench to loosen or tighten any of the tightening screws.
- 3 Use torque wrench to verify tightening torque value on each screws.

Disassembly Instruction

- 1 Loosen the clamping screws gradually in the cross sequence shown in Figure-1.
- 2 Do not remove the clamping screws completely.
- 3 For Tollok product type TLK400 and 401 go to step 6, otherwise stop after step 5.
- 4 Insert the screws into the dismantling threads of the front cone or inner ring and tighten gradually in the cross sequence shown in Figure-1.
- 5 In case of difficulties lightly hammer the releasing screws. Slide out Tollok unit from the hub/shaft.
- 6 Continue further for product type TLK400 and 401.
- 7 Remove all clamping screws. Insert the releasing screws in to the threaded holes of the front cone.
- 8 Righten releasing screws gradually in the cross sequence shown in Figure-1.
- 9 During the first round of tightening all releasing screws, apply up to 50% of the tightening torque M_s indicated in the appropriate rating table.
- 10 Repeat above steps 7 and 8, however, this time apply 100% of the tightening torque M_s indicated in the appropriate rating table.
- 11 Remove the front cone and repeat steps 7 through 9 after inserting removing screws in to the middle ring. This will release the back cone.

Note:

- 1 If the element is to be reused, through clean all the elements surfaces lubricate both screws and threads prior to its use with a thin film of light-weight oil.
- 2 Do not use impact wrench to loosen or tighten any of the tightening screws.

Ordering Example

To learn more about the Tollok offering, please contact us today:
866-REXNORD/866-739-6673 (Within the U.S.) +39 0532 816911 (Outside the U.S.)
 Or visit our website **WWW.REXNORD.COM** for more information.

Company Name:.....

Contact Name:.....

Address:.....

Phone No.:.....

Fax No.:.....

Email:.....

Information Required To Order Tollok Product

	Example 1	Example 2	Example 3
Quantity:	50	100	500
Unit Type:	TLK200	TLK603	TLK450
Unit Size:			
d = inch / mm	2 7/16 inch	90 mm	6 inch
D = inch / mm	3.740 inch	6.102 inch	8.268 inch
dw* = inch / mm		2 3/4 inch	
*dw dia. required with TLK6 (shrink disk)			
Special Options			
<input type="checkbox"/> Paint finish	<input type="checkbox"/>	<input checked="" type="checkbox"/>	<input type="checkbox"/>
RAL No.:		RAL 7016	
<input type="checkbox"/> Nickel Plating	<input checked="" type="checkbox"/>	<input type="checkbox"/>	<input type="checkbox"/>
<input type="checkbox"/> Special Packaging Instructions	<input type="checkbox"/>	<input type="checkbox"/>	<input type="checkbox"/>



866-REXNORD/866-739-6673 (Within the U.S.)
+39 0532 816911 (Outside the U.S.)
www.rexnord.com

Why Choose Rexnord?

When it comes to providing highly engineered products that improve productivity and efficiency for industrial applications worldwide, Rexnord is the most reliable in the industry. Commitment to customer satisfaction and superior value extend across every business function.

Delivering Lowest Total Cost of Ownership

The highest quality products are designed to help prevent equipment downtime and increase productivity and dependable operation.

Valuable Expertise

An extensive product offering is accompanied by global sales specialists, customer service and maintenance support teams, available anytime.

Solutions to Enhance Ease of Doing Business

Commitment to operational excellence ensures the right products at the right place at the right time.

REXNORD

Rexnord Company Overview

Rexnord is a growth-oriented, multi-platform industrial company with leading market shares and highly trusted brands that serve a diverse array of global end markets.

Process & Motion Control

The Rexnord Process & Motion Control platform designs, manufactures, markets and services specified, highly engineered mechanical components used within complex systems where our customers' reliability requirements and the cost of failure or downtime are extremely high.

Water Management

The Rexnord Water Management platform designs, procures, manufactures and markets products that provide and enhance water quality, safety, flow control and conservation.