

Servo valves Series LR

Pressure control - LRPA4

3/3-way servo valves for the pressure control (Ø 4-6 mm)
 Selectable sensor range



- » Rotary slide principal, metal to metal seal
- » Pressure sensor and PID
- » Servo valves are fitted ready for installation and function
- » Precise pressure control loops
- » Supply connector for external pressure transmitter

The valve LRPA can be used with an external pressure transducer instead of the internal sensor (ex. for systems with large distances between servo valve and load); this option allows to use sensors for other physical values (e.g. force, speed, torque, etc.) as transmitter for the feedback signal. The servo valves are fitted ready for installation and function, including a base with G1/4 ports and a connector for the plug to supply the valve with energy and command signal.

The servo valves LRPA4 are integrated servopneumatic systems for high precision pressure control loops in pneumatic systems. The devices include a 3/3-way servo valve size 4 resp. 6, a pressure sensor, an electronic PID-controller and the driver electronic for the servo valve. The valves are supplied with 24 VDC and an analogue command signal. There are an analogue output for the real output value and 2 binary outputs for additional system informations.

GENERAL DATA

Power supply	24 VDC +/- 10%, ripple max. 0.5 Vss, max. 0,8 A	
Input specified value	0-10VDC vs. 100 kohm; 0-20mA vs. 500 ohm; 4-20mA vs. 500 ohm	
Output "in-position" signal	"LIMIT ERROR": open-collector verso GND, max. 20 mA, nessuna protezione contro il sovraccarico	
Output "feedback" signal	0-10 VDC, max 10mA	
Repeatability	< 0.03 % FS	
Accuracy	< 0,1% FS related to sensor output signal	
Alimentazione elettrica verso l'esterno	approx. 24 VDC, max. 100 mA	
"Feedback" signal	0- 10 V vs. 100kohm; 0-20 mA vs. 500 ohm; 4-20 mA vs. 625 ohm	
Maximum flow rate (fully opened)	6 bar to 0 bar:	550 NI/min (LRPA3-34) 780 NI/min (LRPA3-36)
	6 bar to 5 bar:	300 NI/min(LRPA3-34) 450 NI/min (LRPA3-36)
Temperature range	0 to 50°C	
Relative humidity of air	max. 90%	
Weight	approx. 1,0 Kg	
Medium	clean air, oiled or not oiled, 5 µm filtered	
Linearity	< +/- 0,01 %	
Switching time without load (LRPA434)	from 2,5 to 3,0 bar: 8ms; from 2,5 to 2,0 bar: 13ms; from 2,5 to 5,0 bar: 18ms (*)	
Switching time without load (LRPA436)	from 2,5 to 3,0 bar: 7ms; from 2,5 to 2,0 bar: 9ms; from 2,5 to 5,0 bar: 12ms (*)	
Switching time with load of 1000 cm3 (LRPA434)	from 2,5 to 3,0 bar: 50ms; from 2,5 to 2,0 bar: 100ms; from 2,5 to 5,0 bar: 240ms (*)	
Switching time with load of 1000 cm3 (LRPA436)	from 2,5 to 3,0 bar: 35ms; from 2,5 to 2,0 bar: 65ms; from 2,5 to 5,0 bar: 145ms (*)	
	(*) Working pressure: 6 bar	

CODING EXAMPLE

L | **R** | **P** | **A** | **4** | **-** | **3** | **4** | **-** | **2** | **-** | **2** | **-** | **00**

L	SERIES: L = Proportional servo valves
R	TECHNOLOGY: R = rotary
P	VERSION: P = pressure control
A	ELECTRONICS A = analogic
4	MODEL: 4 = with sub-base
3	FUNCTION: 3 = 3 way
4	DIAMETER: 4 = 4 mm 6 = 6 mm
2	INPUT SIGNAL: 2 = 0-10 V 3 = 0-20 mA 5 = 4-20 mA
2	FEEDBACK SIGNAL: 2 = 0-10 V external 3 = 0-20 mA external 5 = 4-20 mA external B = 1 bar internal C = 2,5 bar internal D = 10 bar internal
00	CABLE: 00 = no cable

Accessories: CS-PF07CB; CS-PM04CB

PNEUMATICAL INSTALLATION

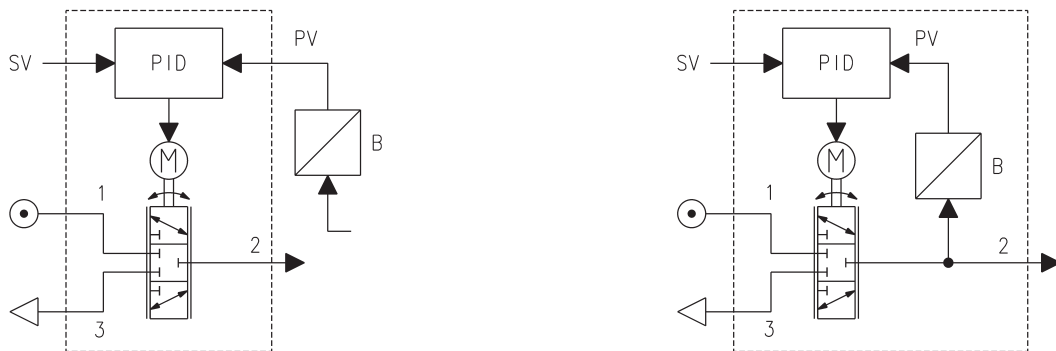

SV= setpoint value
 PV= process value
 B= sensor
 PID= proportional control, integrative, derivative

SERVO VALVES LRPA4 - PNEUMATICAL INSTALLATION

The tubes must have an inner diameter acc. to the size of the valves to prevent pressure drops:
 at least 4 mm for LRPA4-34
 at least 6 mm for LRPA4-36.

For LRPA with internal sensor the tubes to the load should be as short as possible (not more than 2 m).
 The valves are optimally adjusted by the factory for closed load volumes (no permanent air consumption) of approx. 0.25 l to 2 l min.

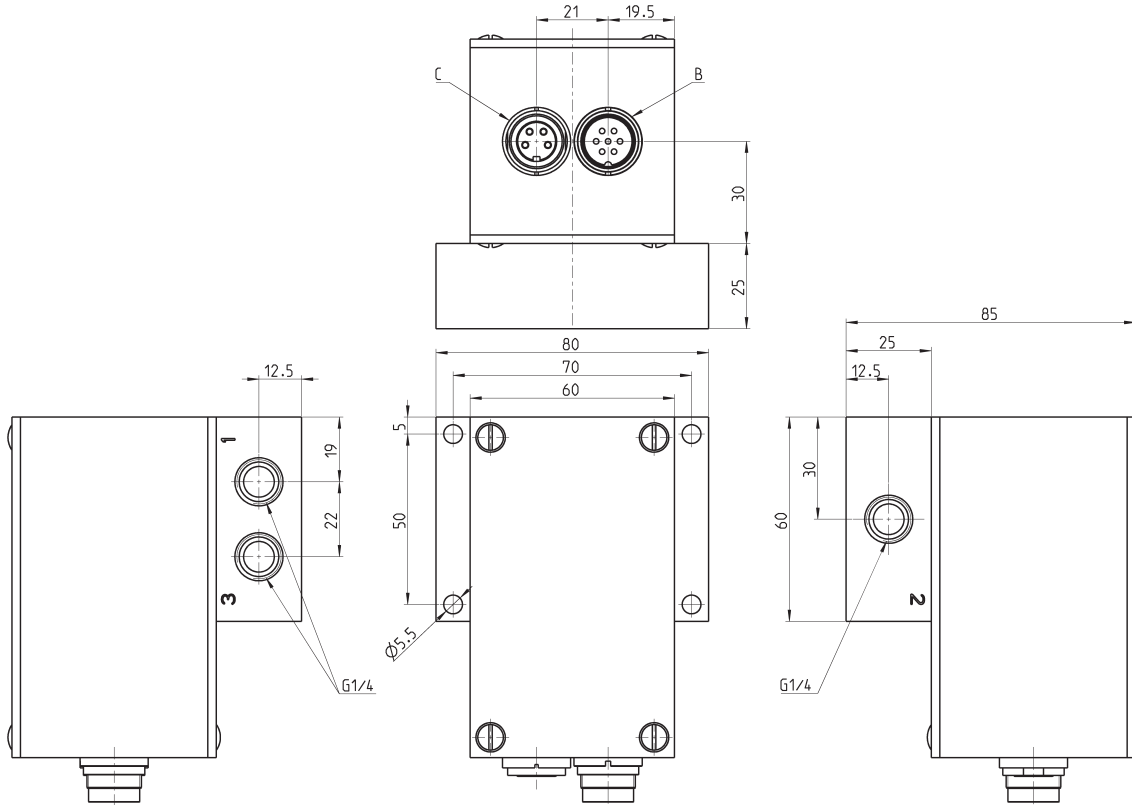

B = supply connector (7 poles male)
 C = connector for the external pressure transmitter (4 pole female)

C - Connector for external pressure transmitter (4 pole female) only for LRPA4-XX-X-2/3/5-00 with external sensor

PIN	FUNCTION	NOTES
1	Output supply	To the transmitter, approx. 24 VDC to pin 2
2	GND	Internal connection to GND power supply
3	Input feedback signal(Process Value)	0-10 V or 0-20 mA or 4-20 mA vs. pin 2
4	NC	

B - Supply connector (7 poles male)

PIN	FUNCTION	NOTES
1	Power supply +24 VDC	
2	Power supply GND	
3	Input command signal (Setpoint Value)	0-10 VDC or 0-20 mA or 4-20mA. The total range of this signal corresponds to the total range of the sensor for the feedback signal. The output pressure follows always this signal. Therefore the signal has to have a high signal quality: if, for example, the sensor has a range of 10 bar, a ripple of 10 mV on the command signal will generate a ripple of 10 mbar on the output pressure.
4	GND input command signal	Pin 4 and 2 should be connected. If that is not possible, the voltage between both GND's may not increase +/- 30 V.
5	Output "ERROR"	see technical data
6	Output "LIMIT"	see technical data
7	Output feedback signal	0-10 VDC vs. pin2. The accuracy-fault of that signal is about 2% and there is an offset of approx. 150 mV. Don't use it for precise documentations. The accuracy of controlling itself is much better.