

Series D valve islands, Size 2, Multipole and Fieldbus

New

Fieldbus connection with the most common communication protocols
PROFIBUS-DP, PROFINET, CANopen, EtherNET/IP, EtherCAT and IO-Link



Multipole connection with 25 or 44 pins

Valve functions: 2x3/2; 5/2; 5/3 CC, CO, CP

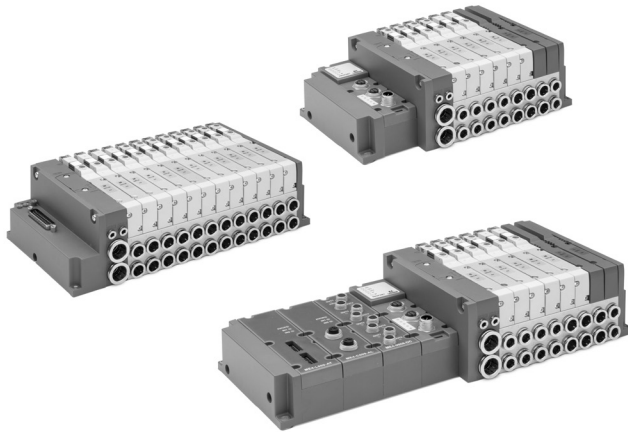

- » Valve size 16 mm
- » Compact design
- » Individual modular subbases in technopolymer
- » Highly expandable electrically and pneumatically
- » Flexibility in connecting and exchanging I/O modules
- » COILVISION technology to monitor performance parameters
- » Same subbase for monostable and bistable valves
- » Possibility to transmit operational data through WLAN
- » Blinking LEDs indicating different types of operating faults

Thanks to the large range of options available, the Series D2 valve island represent an excellent solution for all those applications that require pneumatic and electrical functions in restricted spaces.

The different electrical connection possibilities allow to create Islands with a high number of valve positions and different pressure zones. Moreover, the fieldbus version can manage both digital and analog electric input and output signals.

Small dimensions, high flows, subbases with individual pneumatic and electric modules, an easy subbase connection system, constant diagnosis and monitoring of performance parameters make this series a particularly innovative product.

One of the features of this series is the monitoring function regarding the correct operating of the solenoid valve.

The electronics installed both in the subbase and in the Sub-D and multi-serial connection module, enables to constantly monitor the efficiency of the driving coil of the solenoid valve.

Possible variations with respect to the ideal operating conditions, for example a higher power consumption, variation in response times and an increased temperature are indicated through different ways of blinking by the LED on the solenoid valve and by an electric alert signal that is sent to the PLC through the Sub-D module connecting cable or, in case of the multi-serial connection module, directly through the communication protocol.

Manual, instruction sheet and configurator are available on the site <http://catalogue.camozzi.com> or by means of the QR code on the product's label.

GENERAL DATA

PNEUMATIC SECTION	
Valve construction	spool with seals
Valve functions	5/2 monostable and bistable 5/3 CC; CO; CP 2 x 3/2 NC 2 x 3/2 NO 1 x 3/2 NC + 1 x 3/2 NO
Materials	spool: AL spool seals: HNBR other seals: NBR body: AL end caps: polymer subbase size 1: polymer
Connections	outlet 2 and 4, tube Ø6, Ø8, Ø10 supply 1: tube Ø10, Ø12, Ø14 supply 12/14: tube Ø4 exhaust 3 and 5: tube Ø10, Ø12, Ø14 exhaust 82/84: tube Ø4
Temperature	0 ÷ 50°C
Air characteristics	compressed, filtered and non-lubricated air in class [7:4:4] according to ISO 8573-1:2010. In case lubrication should be necessary, only use oils with a maximum viscosity of 32 Cst and the version with external servo-pilot supply. The air quality of the servo-pilot supply must be of class [7:4:4] according to ISO 8573-1:2010 (do not lubricate).
Valve sizes	2 = 16 mm
Operating pressure	-0,9 ÷ 10 bar
Pilot pressure	3 ÷ 7 bar 4,5 ÷ 7 bar (with operating pressure exceeding 6 bar for the version 2x3/2)
External pilot pressure	SEE GRAPHS
Flow rate	950 NL/min
Mounting position	any position
Protection class	IP65
ELECTRICAL SECTION MULTIPOLE VERSION	
Type of Sub-D connector	25 or 44 pins
Max. absorption	0.8 A (with Sub-D connector 25 pins) 1,5 A (with Sub-D connector 44 pins)
Supply voltage	24 V DC +/- 10%
Max. number of coils to operate	22 on 11 valve positions (with Sub-D connector 25 pins) 38 on 19 valve positions (with Sub-D connector 44 pins)
Signalling LED	Multipole: green LED - presence of power red LED - anomaly Valve: yellow LED - presence of power blinking yellow LED - operating fault
ELECTRICAL SECTION FIELD BUS VERSION	
General data	see Multi-serial Modules section on the next pages
Max. absorption	2.5 A
Supply voltage	24 V DC +/-10% logic supply 24 V DC +/-10% power supply
Max. number of coils to operate	128 on 64 valve positions
Max. number of digital inputs	128
Max. number of analog inputs	16
Max. number of digital outputs	128
Max. number of analog outputs	16
IO-Link version	
Max n° of coils to operate	64 on 32 valve positions
Input and Output	No
Type of port	Class B
IODD Configuration file	up to 12, 24 or 32 valve positions per island
(The IO-Link module on the valve island is auto-configured to operate with the right IODD)	
More information can be found at http://catalogue.camozzi.com Series D "Instructions for use and maintenance"	

PNEUMATIC CONNECTION

The subbases, in their different configurations, include tube connection cartridges. Through the removal of fixing clips it is possible to replace these cartridges and adapt them to the necessary dimension. The pneumatic part is the same for both the Multipole and Serial version. The tie rods with different fixed lengths that unite the subbases, can be extended individually through additional tie rods for odd positions.

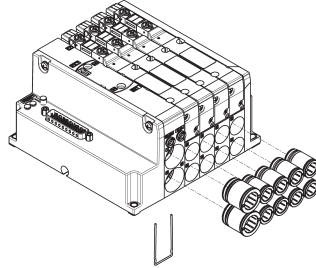

INTERMEDIATE SUBBASES

Intermediate subbases with a diaphragm or additional supply function allow to create diversified pressure and/or exhaust zones, add an incoming air flow and increase the exhaust flow. Furthermore there are subbases available that, besides the aforementioned functions, can interrupt the pneumatic actuation to the coils. This prevents, independently of the electric signal being present or not, to actuate the monostable and bistable valves. The intermediate subbases do not need to be calculated in the number of valve positions.

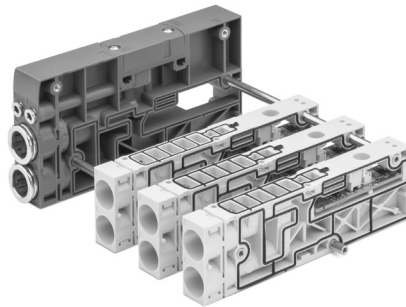

SERVOPILOT

The initial supply and exhaust base can be changed through rotating the upper device of the selected type of servo-pilot. The change from internal to external servo-pilot is obtained without replacing the initial base, this allows for example to include or section the island, adapting its operation also after its installation, for example with valves that operate with vacuum or reduced pressures. The arrow indicates the selected type of servo-pilot.



CONFIGURATOR

The island configuration is of minimum three positions including the possible base for additional supply and/or exhaust. The maximum number of positions depends on the selected type of electrical connection. To correctly compose the commercial code and to download drawings, please use the configurator present at <http://catalogue.camozzi.com> in the sections "Configurators" or "Camozzi Partcommunity".

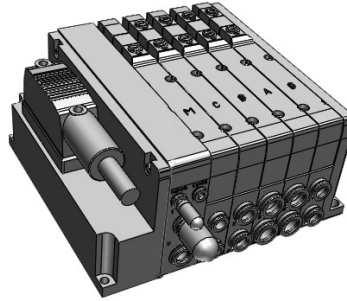

MULTIPOLE VERSION

The multipole version can be connected quickly and safely through the connecting cable with angled outlet of 25 or 44 pins to the electric Sub-D connector integrated in the island. The single modularity of the subbases allows to create islands with up to a maximum of 11 or 19 valve positions according to the type of connecting cable used.

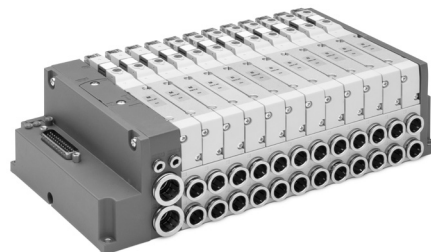

FIELD BUS and IO-LINK VERSION

The new CX4 fieldbus module integrated in the Series D valve island enables to interface with the most common fieldbus protocols. Besides managing the pneumatic part (the same as the Multipole version) different kinds of electric modules can be managed. With this configuration it is possible to enlarge the pneumatic part up to a maximum of 64 valve positions with double command and the electric part up to 128 digital inputs and 128 digital outputs, besides 16 analog inputs and 16 analog outputs. Besides the standard voltage and current versions, the analog modules are also available in 2-channel Bridge, RTD and TC versions.

Also in the IO-Link version, the interface module is part of the Series CX4.

In this configuration, the I/O Modules cannot be integrated in the island, a maximum of 64 coils can be managed on 32 valve positions.

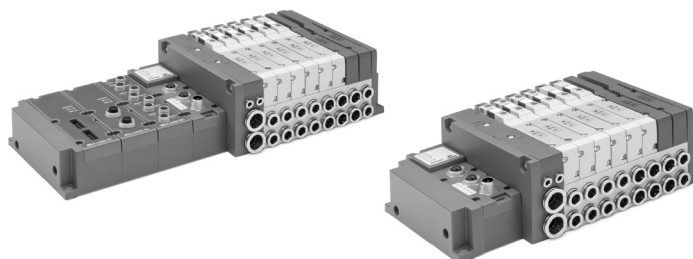

ELECTRICAL MODULE

The electric modules are composed of two parts: the base to connect the different modules, which is the same for all types, and different covers on which the connectors are positioned. This solution enables to easily change the connection points with the sensors or functions of the machine. Also the electric modules, like the subbases in the pneumatic part, can be added or removed thanks to the modular connection system.

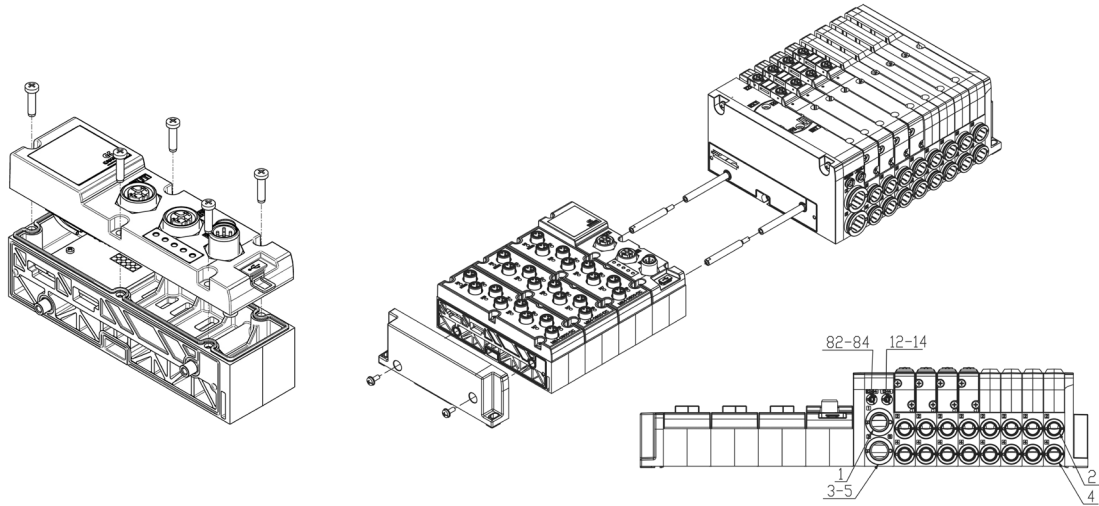

COILVISION

This is a standard function in all our valve islands with Multipole and Serial connection. Its purpose is to monitor the proper function of each solenoid valve individually, particularly the solenoid. The electronics installed in the subbase allows to constantly monitor the efficiency of the driving coil of the solenoid valve. Possible variations with respect to the ideal operating conditions, like for example a higher power consumption, different response times or an increased temperature, are reported by means of a blinking yellow LED of the interested solenoid. Besides the blinking of this LED, also a general red LED blinks located on the Sub-D module. These indications are combined with an alert message sent to the PLC. By selecting code W from the "Interface" menu of the encryption code, besides the described signals, it is possible to gather all operational data of the islands and send them through WLAN to the corporate net or onto the Cloud to be analysed.

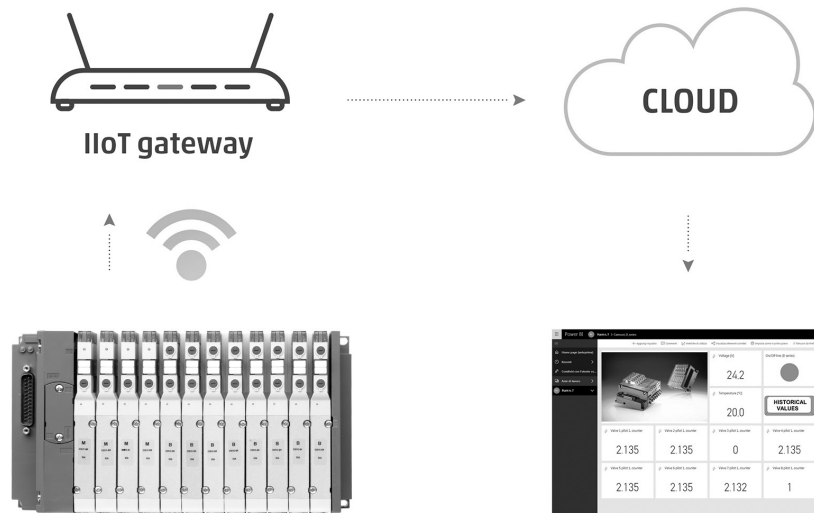

CODING EXAMPLE - MULTIPOLE VERSION

DM	C	2	M	W	R	A	-	15R	-	4BQH4CX3D	-	3M2L3M2BC	-	DS	R
-----------	----------	----------	----------	----------	----------	----------	----------	------------	----------	------------------	----------	------------------	----------	-----------	----------

DM	MODULAR ISLAND
C	VALVE C = VC Model
2	SIZE 2 = 16 mm
M	ELECTRICAL CONNECTION M = Multipole 25 pin PNP Q = Multipole 44 pin PNP
W	INTERFACE O = without interface W = WLAN
R	MANUAL OVERRIDE P = push button R = with push and turn device
A	SERVO-PILOT SUPPLY A = internal B = external
15R	CONNECTOR 0 = without connector CONNECTOR R WITH CABLE 03R = 3 mt 05R = 5 mt 10R = 10 mt 15R = 15 mt 20R = 20 mt 25R = 25 mt
4BQH4CX3D	<p>SUBBASES</p> <p>Metric: B = cartridges tube Ø6 C = cartridges tube Ø8 D = cartridges tube Ø10</p> <p>Inches: L = cartridges tube Ø1/4" C = cartridges tube Ø5/16" P = cartridges tube Ø3/8"</p> <p>SUBBASES DIAPHRAGM Q = diaphragm on channels 1, 3, 5 R = diaphragm on channel 1 S = diaphragm on channels 3 and 5</p> <p>WITH DIAPHRAGM AND EXTERNAL SERVO-PILOT SUPPLY QT = diaphragm on channels 1, 3, 5; 12/14 external RT = diaphragm on channel 1; 12/14 external ST = diaphragm on channels 3, 5; 12/14 external</p> <p>WITH DIAPHRAGM AND INTEGRATED SILENCER QH = diaphragm on channels 1, 3, 5 RH = diaphragm on channel 1 SH = diaphragm on channels 3, 5</p> <p>SUBBASE FOR ADDITIONAL FLOW X = supply (1) and exhausts (3, 5) XH = supply (1) and exhausts (3, 5) with integrated silencer</p> <p>INTERFACE SUBBASE FOR ADDITIONAL FLOW WITH EXTERNAL SERVO-PILOT SUPPLY XT = additional supply (1) and exhausts (3, 5)</p> <p>FOR POWER SUPPLY K = separation of power supply</p>
3M2L3M2BC	VALVES M = 5/2 monostable B = 5/2 bistable C = 2x3/2 NC A = 2x3/2 NO G = 2x3/2 (NC+NO) V = 5/3 CC K = 5/3 CO N = 5/3 CP L = free position W = position without valve
DS	TERMINALS AND INTERMEDIATE PLATES Tube dimensions for port sizes 1,3,5
R	FIXING TYPE = direct R = DIN rail

The choice of the cartridge made in the Terminal Plates section is also valid for the diaphragm and additional sub-bases

CODING MULTIPOLE VERSION

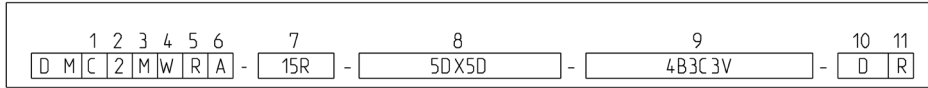
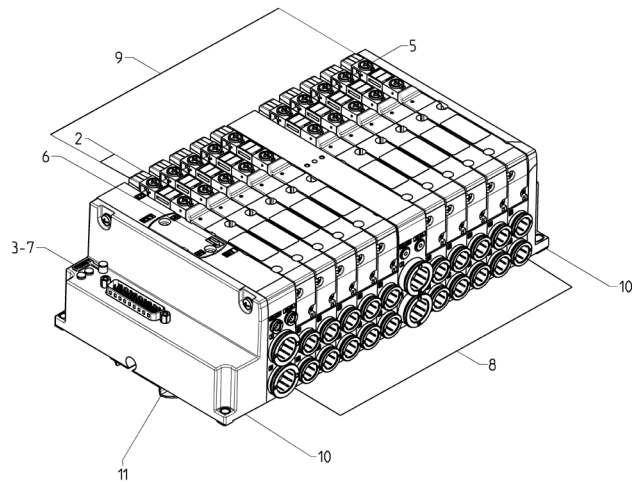

(1)	VALVE MODEL VC	(2)	SIZE	(3)	ELECTRICAL CONNECTION	(4)	INTERFACE	(5)	MANUAL OVERRIDE	(6)	SERVO-PILOT
	DMC		2		M Q		O W		P R		A B
(7)	CONNECTION	(8)	SUBBASES		(9)	VALVES	(10)	TERMINAL PLATES		(11)	MOUNTING
	0		METRIC INCHES			M	METRIC INCHES			R	
	03R		B	L		B	D	P			
	05R		C	C		C	DS	R			
	10R		D	P		A	E				
	15R		SUBBASES DIAPHRAGM			G	F				
	20R		Q			V					
	25R		R			K					
			S			N					
			WITH DIAPHRAGM AND EXTERNAL SERVO-PILOT SUPPLY			L					
			QT			W					
			RT								
			ST								
			WITH DIAPHRAGM AND INTEGRATED SILENCER								
			QH								
			RH								
			SH								
			SUBBASE FOR ADDITIONAL FLOW								
			X								
			XH								
			INTERFACE SUBBASE FOR ADDITIONAL FLOW WITH EXTERNAL SERVO-PILOT SUPPLY								
			XT								
			FOR POWER SUPPLY								
			K								

CODING EXAMPLE - FIELDBUS VERSION

DM C 2 01 W R A - 2A2Q - 2B2CQH4DX4B - 3M2L3M2B2C - E R

DM	MODULAR ISLAND
C	VALVE C = VC Model
2	SIZE: 2 = 16 mm
01	PROTOCOL 00 = Base without Fieldbus coverage 01 = PROFIBUS 03 = CANopen 04 = Ethernet/IP 05 = Ethercat 06 = PROFINET 07 = IO-LINK (not configurable with input and output modules)
W	INTERFACE 0 = without interface W = WLAN
R	MANUAL OVERRIDE P = push button R = with push and turn device
A	SERVO-PILOT SUPPLY A = internal B = external
2A2Q	INPUT AND OUTPUT MODULES 0 = without A = 8 Digital inputs M8 B = 16 Digital inputs, terminal block connection C = 2 Analog inputs (config. 0-10V,±10V,0-20mA,4-20mA,±20mA) M12 D = 2 Analog inputs (config. 0-10V,±10V,0-20mA,4-20mA,±20mA), terminal block E = 2 Inputs, BRIDGE M12 F = 2 Inputs, BRIDGE, TERMINAL BLOCK CONNECTION G = 2 Inputs, RTD M12 (PT100, PT200, PT500, PT1000) H = 2 Inputs, RTD TERMINAL BLOCK CONNECTION (PT100, PT200, PT500, PT1000) L = 2 Inputs, TC M12 (THERMOCOUPLES) M = 2 Inputs, TC TERMINAL BLOCK CONNECTION (THERMOCOUPLES) Q = 8 Digital outputs M8 R = 16 Digital outputs, terminal block connection T = 2 Analog outputs (config. 0-10V,±10V,0-20mA,4-20mA,±20mA), M12 U = 2 Analog outputs (config. 0-10V,±10V,0-20mA,4-20mA,±20mA), terminal block (Push-in) W** = Closed base without I/O cover
2B2BQH4DX4B	SUBBASES Metric: B = Cartridges tube Ø6 C = Cartridges tube Ø8 D = Cartridges tube Ø10 Inches: L = Cartridges tube Ø1/4" C = Cartridges tube Ø5/16" P = Cartridges tube Ø3/8" SUBBASE DIAPHRAGM Q = Diaphragm on channels 1, 3, 5 R = Diaphragm on channel 1 S = Diaphragm on channels 3 and 5 WITH DIAPHRAGM AND EXTERNAL SERVO-PILOT SUPPLY QT = Diaphragm on channels 1, 3, 5; 12/14 External RT = Diaphragm on channel 1; 12/14 External ST = Diaphragm on channels 3, 5; 12/14 External WITH DIAPHRAGM AND INTEGRATED SILENCER QH = Diaphragm on channels 1, 3, 5 RH = Diaphragm on channel 1 SH = Diaphragm on channels 3, 5 SUBBASE FOR ADDITIONAL FLOW X = Supply (1) and exhausts (3, 5) XH = Supply (1) and exhausts (3, 5) with integrated silencer INTERFACE SUBBASE FOR ADDITIONAL FLOW WITH EXTERNAL SERVO-PILOT SUPPLY: XT = Additional supply (1) and exhausts (3, 5) FOR POWER SUPPLY K = separation of power supply
3M2L3M2B2C	VALVES M = 5/2 Monostable B = 5/2 Bistable C = 2x3/2 NC A = 2x3/2 NO G = 2x3/2 (NC+NO) V = 5/3 CC K = 5/3 CO N = 5/3 CP L = Free position
E	TERMINAL PLATES Fittings on tube ports 1, 3, 5 Metric: D = Cartridge tube Ø10 E = Cartridge tube Ø12 F = Cartridge tube Ø14 Inches: DS = Cartridge tube Ø10 with external silencer (2939-10) ES = Boccole tubo Ø12 e silenziatore esterno (2939-12) P = Boccola tubo Ø3/8" R = Boccola tubo Ø1/2"
R	FIXING TYPE = direct R = DIN rail

The choice of the cartridge made in the Terminal Plates section is also valid for the diaphragm and additional sub-bases
**The closed base without I/O cover must always be placed after the other modules if present e.g.: DMC201WRA-2A2QW...

FIELDBUS VERSION CODING

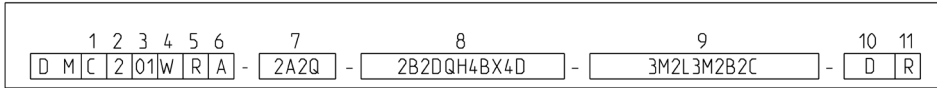
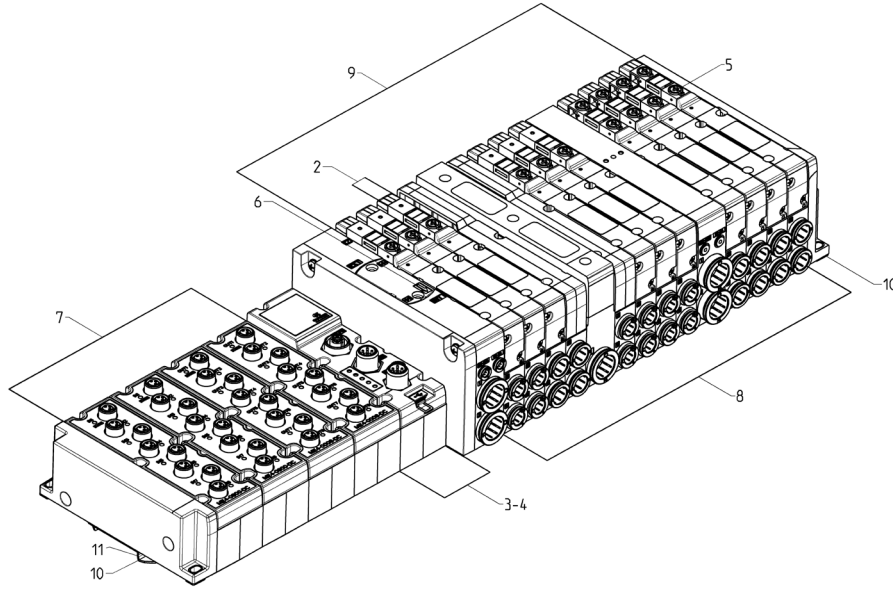

(1)	VALVES	(2)	SIZE	(3)	PROTOCOL	(4)	INTERFACE	(5)	MANUAL OVERRIDE	(6)	SERVO-PILOT
	DMC		2		00		0		P		A
					01		W		R		B
					03						
					04						
					05						
					06						
					07						
(7)	INPUT AND OUTPUT MODULES			(8)	SUBBASES	(9)	VALVES	(10)	TERMINAL PLATES	(11)	FIXING
	A				METRIC	INCHES	M		METRIC	INCHES	R
	B				B	L	B		D	P	
	C				C	C	C		DS	R	
	D				D	P	A		E		
	E				SUBBASE WITH DIAPHRAGM		G		F		
	F					Q	V				
	G					R	K				
	H					S	N				
	L				SUBBASE WITH DIAPHRAGM AND EXTERNAL SERVO-PILOT SUPPLY		L				
	M					QT	W				
	Q					RT					
	R					ST					
	T				SUBBASE WITH DIAPHRAGM AND SILENCER						
	U					QH					
						RH					
						SH					
					SUBBASE FOR ADDITIONAL FLOW						
						X					
						XH					
					INTERFACE SUBBASE FOR ADDITIONAL FLOW WITH EXTERNAL SERVO-PILOT SUPPLY						
						XT					
					FOR POWER SUPPLY						
						K					

MULTIPOLE version COMPONENTS

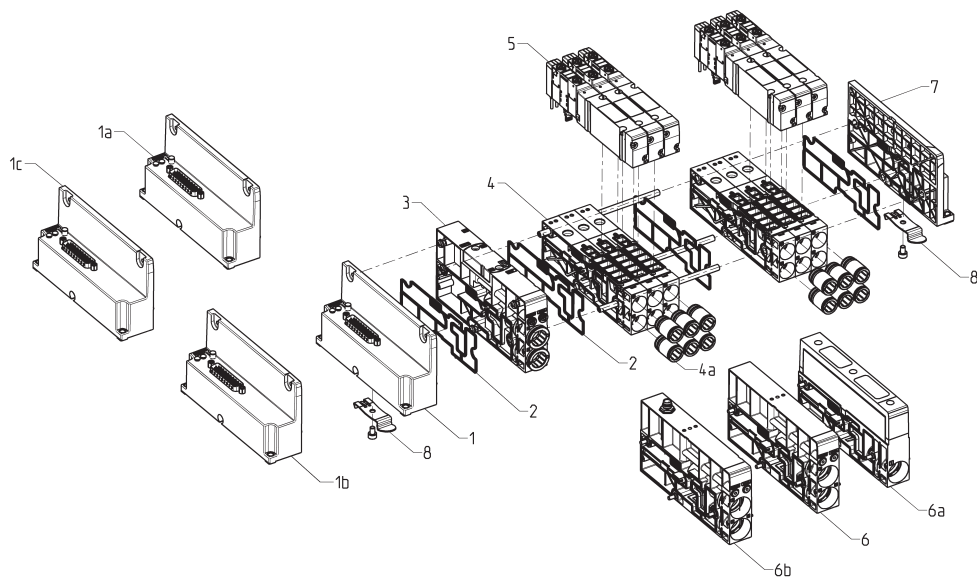

COMPONENTS	
1	Electric interface group - multipole 25 pins
1a	Electric interface group - multipole 25 pins WLAN interface
1b	Electric interface group - multipole 44 pins
1c	Electric interface group - multipole 44 pins WLAN interface
2	Interface seals
3	Initial pneumatic supply module
4	Modular subbase size 2
4a	Interchangeable quick-release couplings
5	Solenoid valve size 2
6	Additional module to convey supply and exhaust channels
6a	Module to supply and to silence the exhaust channel
6b	Module to separate power supply
7	Terminal plate
8	Mounting bracket for DIN rail

FIELDBUS version COMPONENTS

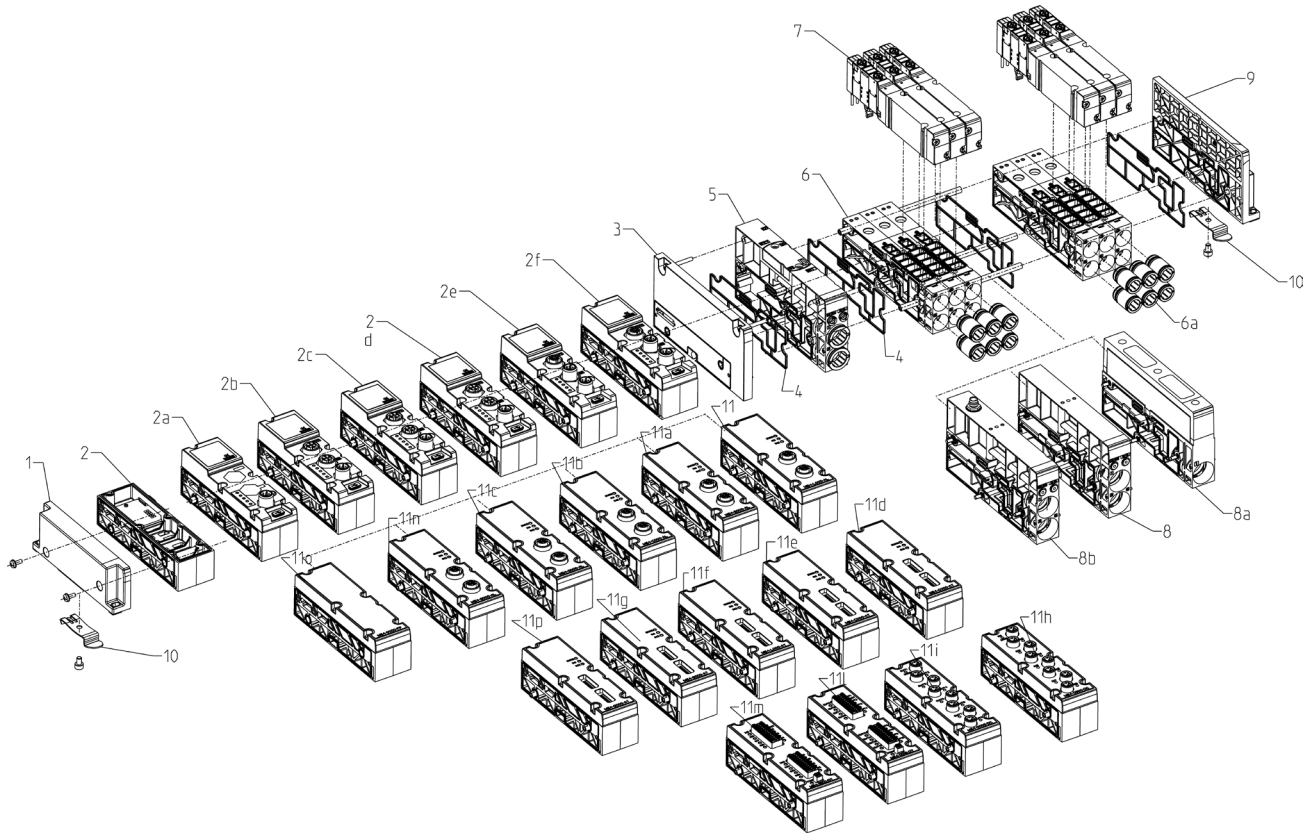

COMPONENTS			
1	Terminal module	9	Terminal plate
2	IO-Link module	10	Mounting bracket for DIN rail
2a	PROFINET module	11	2 Analog voltage/current Inputs, M12
2b	EtherCAT module	11a	2 Analog load cell Inputs, M12
2c	EtherNet/IP module	11b	2 Analog thermocouple Inputs, M12
2d	CANopen	11c	2 Analog RTD Inputs, M12
2e	PROFIBUS module	11d	2 analog outputs, M12
2f	IO-Link module	11e	2 Analog voltage/current Inputs, terminal block
3	Fieldbus module interface	11f	2 Analog load cells Inputs, terminal block
4	Interface seal	11g	2 Analog thermocouple Inputs, terminal block
5	Initial pneumatic supply module	11h	2 Analog RTD Inputs, terminal block
6	Modular subbase size 2	11i	2 analog outputs, terminal block
6a	Interchangeable quick-release couplings	11l	8 Digital Inputs
7	Solenoid valve size 2	11m	8 Digital Outputs
8	Additional module to convey supply and exhaust channels	11n	16 Digital Inputs
8a	Module to supply and to silence the exhaust channel	11o	16 Digital Outputs
8b	Module to separate power supply	11p	2 Analog Out terminal block

MULTIPOLE version 25 and 44 pin DIMENSIONS

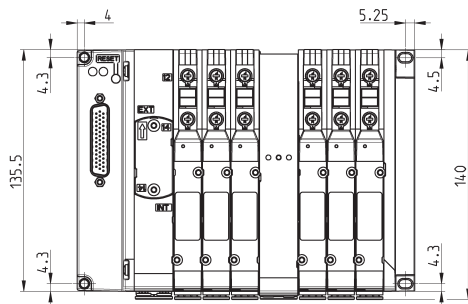
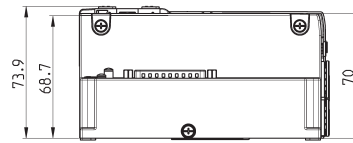
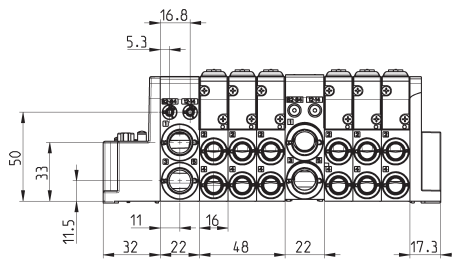

FIELDBUS version DIMENSIONS

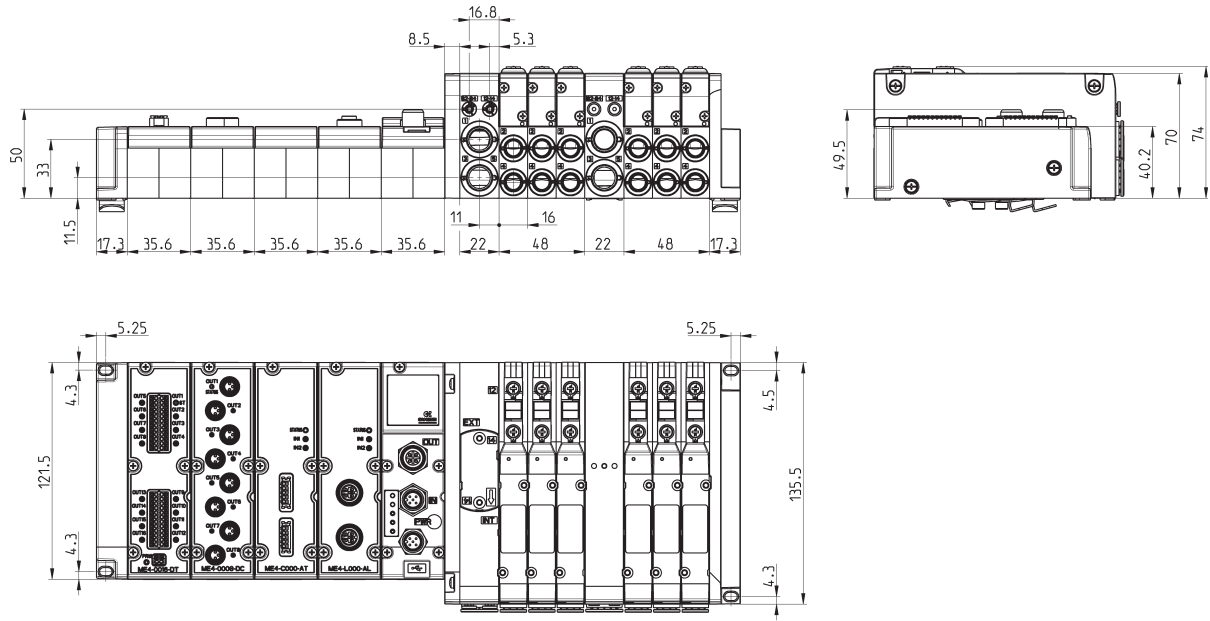

CODING EXAMPLE

D	2	E	VC	-	M	P
D	SERIES					
2	SIZE: 2 = 16 mm					
E	VERSION: E = solenoid valve					
VC	COMPONENT: VC = plugin valve					
M	TYPE OF SOLENOID VALVE M = 5/2 monostable B = 5/2 bistable C = 2 x 3/2 NC A = 2 x 3/2 NO G = 2 x 3/2 (NC+NO) V = 5/3 CC K = 5/3 CO N = 5/3 CP					
P	MANUAL OVERRIDE: P = push button R = with push and turn device					

AVAILABLE FUNCTION - SYMBOLS FOR SOLENOID VALVES

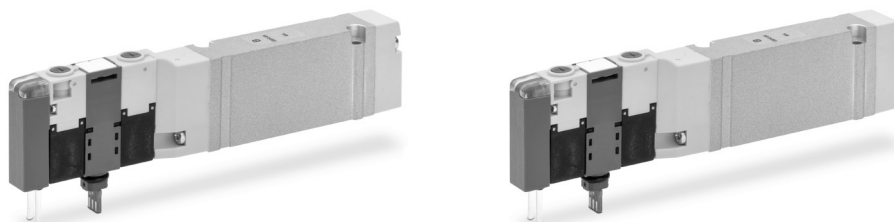
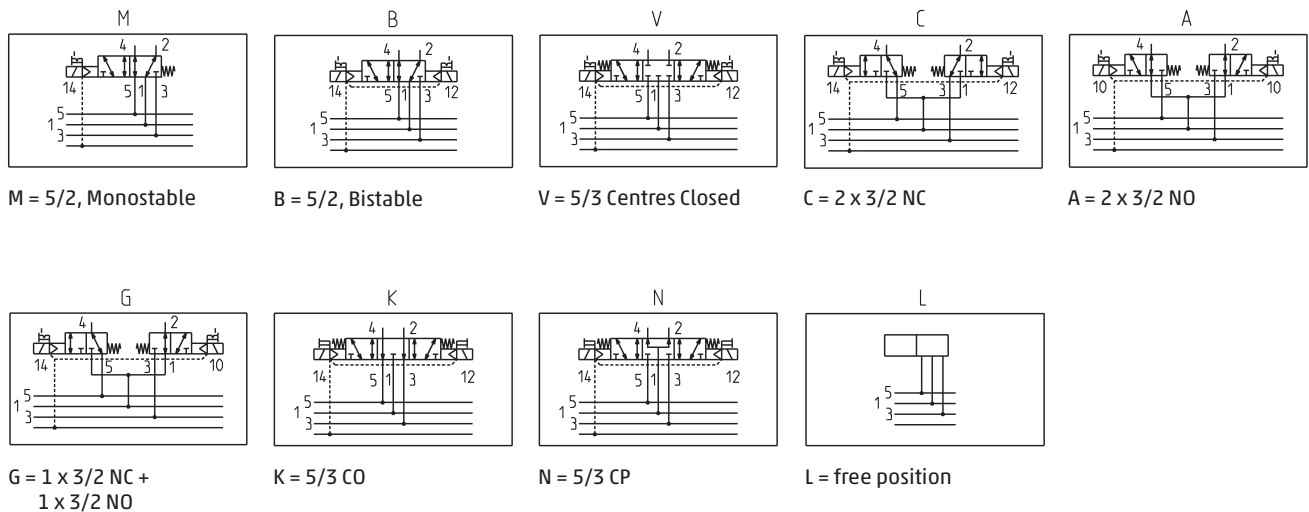

EXTERNAL PILOT PRESSURE GRAPHS

Valve model

B

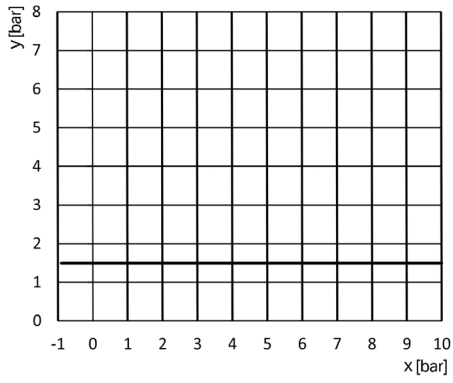

x = Supply pressure
y = Pilot pressure

Valve model

M-V-K-N

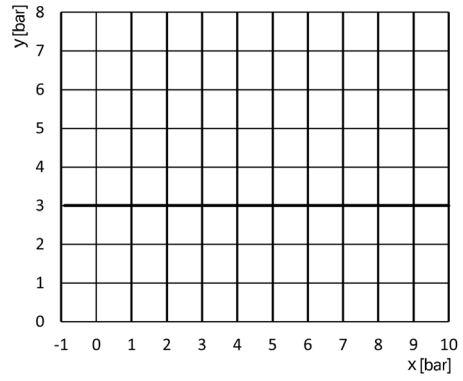

x = Supply pressure
y = Pilot pressure

Valve model

C-A-G

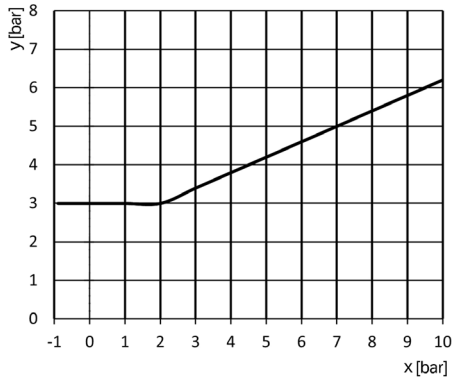

x = Supply pressure
y = Pilot pressure

Free valve position L

The supply includes:
 1 fake valve
 2 fixing screws

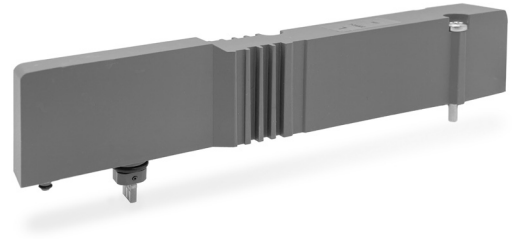

Mod.
D2EVC-L

INTERMEDIATE SUBBASES CODING EXAMPLE

D	AM	2	S	-	QH	-	D	T
----------	-----------	----------	----------	----------	-----------	----------	----------	----------

D	SERIES
AM	ACCESSORIES AM = modular accessories
2	SIZE: 2 = 16 mm
S	COMPONENT: S = modular subbase
QH	INTERMEDIATE DIAPHRAGM SUBBASE Q = diaphragm on channels 1, 3, 5 R = diaphragm on channel 1 S = diaphragm on channels 3, 5 DIAPHRAGM WITH EXTERNAL SERVO-PILOT SUPPLY QT = diaphragm on channels 1, 3, 5; 12/14 external RT = diaphragm on channels 1; 12/14 external ST = diaphragm on channels 3, 5; 12/14 external DIAPHRAGM WITH INTEGRATED SILENCER QH = diaphragm on channels 1, 3, 5 RH = diaphragm on channel 1 SH = diaphragm on channels 3, 5 SUBBASE FOR ADDITIONAL FLOW X = supply (1) and exhausts (3,5) XH = supply (1) and exhausts (3,5) with integrated silencer INTERFACE SUBBASE FOR ADDITIONAL FLOW WITH EXTERNAL SERVO-PILOT SUPPLY XT = additional supply (1) and exhausts (3, 5) FOR POWER SUPPLY K = separation of power supply
D	VERSION: T = without cartridge D = cartridge tube Ø10 E = cartridge tube Ø12 F = cartridge tube Ø14 P = cartridge tube Ø3/8 R = cartridge tube Ø1/2
T	TIE RODS = without tie rods T = with tie rods

MODULE K TO SEPARATE POWER SUPPLY

This module allows to interrupt and provide a separate power supply to the subsequent solenoid valves besides additional supply and exhaust.

You only need to connect the +24V to one of the three pins

- 1 = +24V
- 3 = +24V
- 4 = +24V

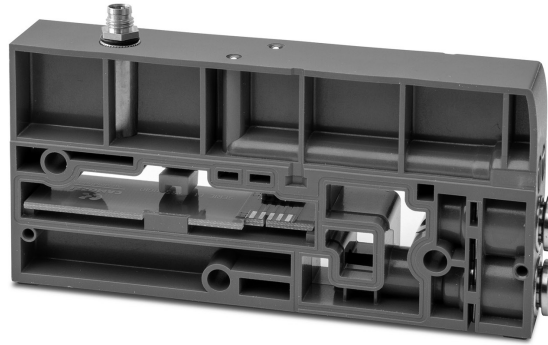
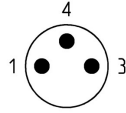

GENERAL DATA	
Connection	M8 3 pins
Dimensions	135,5 x 22 mm
Signalling	None
Supply	24 V DC (+/- 10%)
Protection class	IP 65
Temperature	0°C + 50°C
Material	technopolymer
Weight	340 g

AVAILABLE FUNCTIONS – SUBBASE TYPES

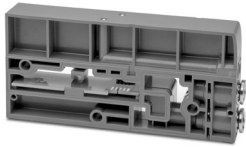

R

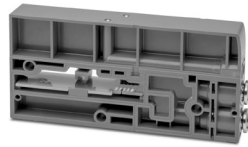

Q

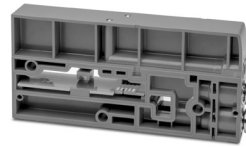

S

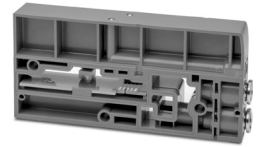

X

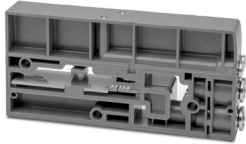

RT

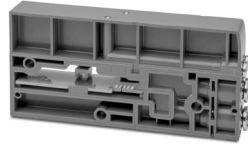

QT

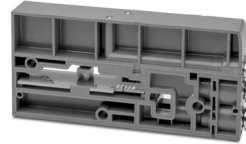

ST

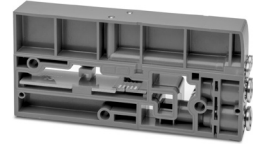

XT

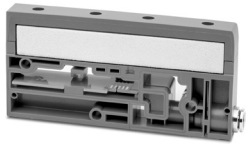

RH

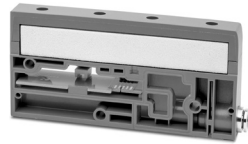

QH

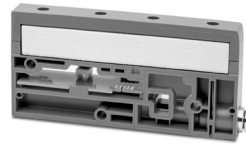

SH

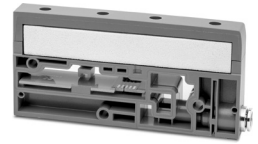

XH

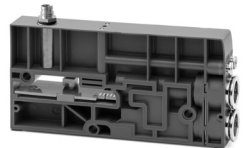

K

- R = diaphragm on channel 1
- Q = diaphragm on channels 1, 3, 5
- S = diaphragm on channels 3, 5
- X = additional supply channel 1 and exhaust channels 3, 5
- RT = diaphragm on channels with external supply 12/14
- QT = diaphragm on channels with external supply 12/14
- ST = diaphragm on channels with external supply 12/14
- XT = additional supply channel 1, 12/14 and exhausts channels 3, 5
- RH = diaphragm on channel 1 with integrated silencer
- QH = diaphragm on channels 1, 3, 5 with integrated silencer
- SH = diaphragm on channels 3, 5 with integrated silencer
- XH = additional supply channel 1 and exhaust channels 3, 5 with integrated silencer
- K = Separation of power supply

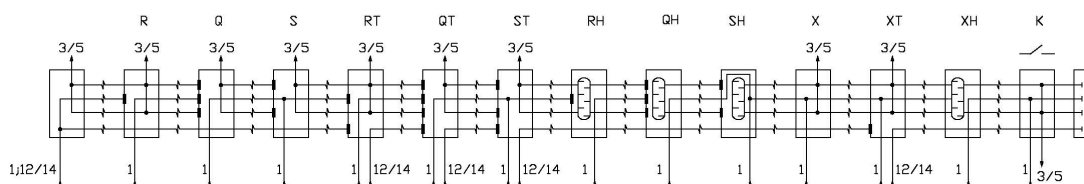

INTERMEDIATE SUBBASE FOR A SEPARATE SERVO-PILOT SUPPLY

In order for the solenoid valves to operate, they need an electric signal and pressure on channel 12/14. This intermediate subbase, available with different diaphragm functions on channels 1 and 3/5, always has channel 12/14 closed, the solenoid valves assembled on the subbases in subsequent positions cannot operate if there is no pressure. In the example below the solenoid valve type M is pneumatically supplied on all channels, solenoid valve B is installed next to subbase XT, which has channel 12/14 closed. The solenoid valve 3/2 which is not part of the island, is always activated under regular operating conditions (as indicated in the image) enabling all solenoid valves to operate properly. In case of any problems, by removing the actuation of this solenoid valve, it is possible to interrupt the functioning of the subsequent positions.

In this condition, the 2x3/2 valves assume the rest position.

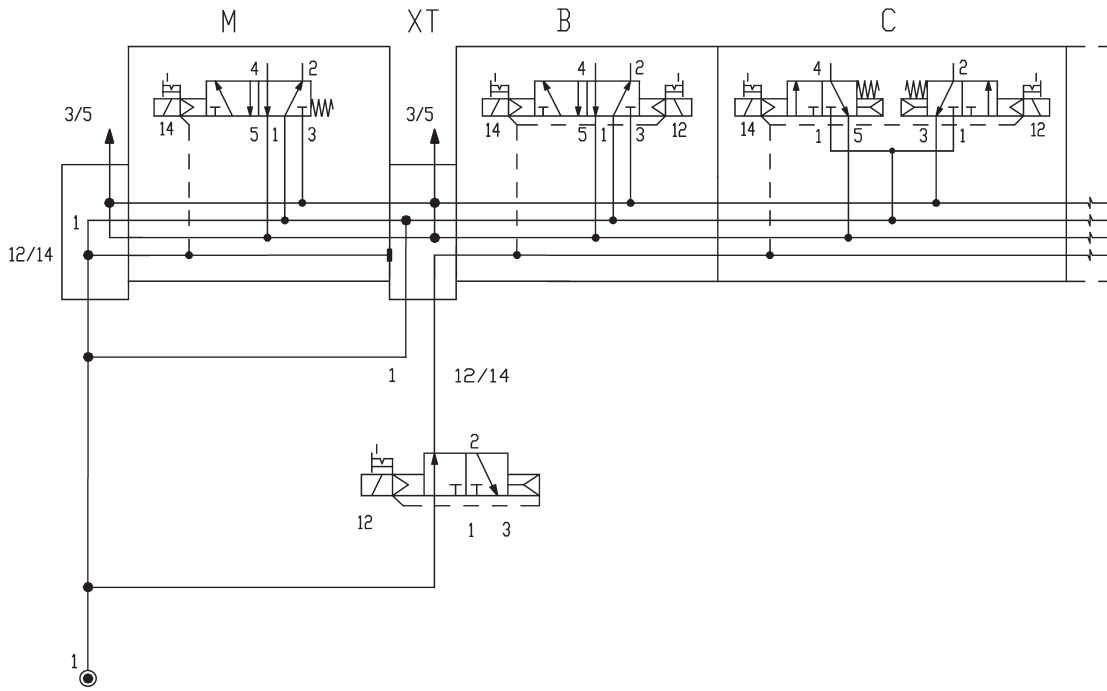

VALVE SUBBASES CODING EXAMPLE

D	AM	2	S	-	A	T
D	SERIES					
AM	ACCESSORIES AM = modular accessories					
2	SIZE 2 = 16 mm					
S	COMPONENT S = modular subbase					
A	TYPE OF CONNECTION		B = Cartridges tube Ø6		B = Cartridges tube Ø1/4	
	T = subbase without cartridges		C = Cartridges tube Ø8		C = Cartridges tube Ø5/16	
			D = Cartridges tube Ø10		D = Cartridges tube Ø3/8	
T	TIE RODS					
	= without tie rods		T = with tie rods			

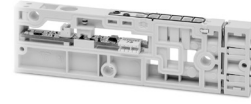

SERIES D2 VALVE ISLANDS

SUPPLY MODULE/SERVOPILOT CODING EXAMPLE

D	AM	2	0	-	KD
D	SERIES				
AM	ACCESSORIES AM = modular accessories				
2	SIZE 2 = 16 mm				
0	SERVO-PILOT SUPPLY 0 = internal / external				
KD	INITIAL PNEUMATIC TERMINAL PLATE				
	KD = cartridge tube Ø10		KP = cartridge tube Ø3/8		
	KE = cartridge tube Ø12		KR = cartridge tube Ø1/2		
	KF = cartridge tube Ø14				

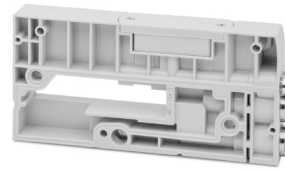

CODING EXAMPLE

D	AM	2	T	-	Q	0
D	SERIES					
AM	ACCESSORIES AM = modular accessories					
2	SIZE 2 = 16 mm					
T	COMPONENT T = electrical terminal plate					
Q	TYPE OF TERMINAL PLATE					
	M = multipole 25 pins		Q = multipole 44 pins			
0	INTERFACE					
	0 = without interface		W = WLAN			



Pneumatic terminal plate

The supply includes:
1 terminal plate
3 fixing screws

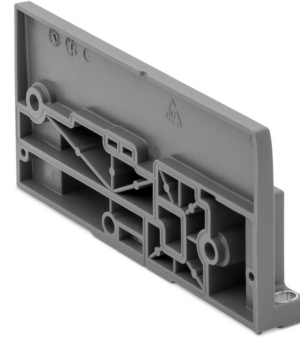

Mod.
DAM20-RT

Connection interface between electrical section and valves

The supply includes:
1 terminal plate
3 fixing screws for valve section
2 fixing screws for serial section
1 interface



Mod.
ME4-00D2-DI

Closing terminal of fieldbus electrical section

The supply includes:
1 terminal plate
2 fixing screws

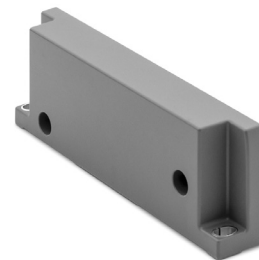

Mod.
CX4AP-L

Multi-serial modules



On this module there are three connectors, one for supply on which it is possible to separate logic supply from power supply and two connectors for the inlet and outlet of the protocol.
 A Micro-USB port enables to interface with a PC and by means of the UVIX configuration software it is possible to monitor and configure both the Multi-serial Module and the I/O Modules. Connectable on the left side.
 These can be configured as PNP or NPN for the Digital Inputs, while for the Analog Inputs, both voltage and current is possible.
 The configuration of the Multi-serial Module and the components connected to it is also possible through different communication protocols.
 In the event of malfunction or breakage, even without power supply, a NFC function enables to download the configuration data, by means of a special App, on an external device to transmit them to a new Multi-serial Module.

The supply includes 2 tie-rods.

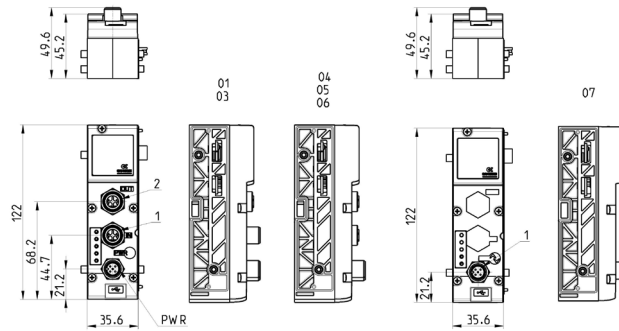

NO WLAN / WITH WLAN	Mod.	Fieldbus Protocol	1	2	Bus-IN connector	Bus-OUT connector
CX4010-0/CX401W-0	01	PROFIBUS	Bus-OUT	Bus-IN	M12 B 5-pin male	M12 B 5-pin female
CX4030-0/CX403W-0	03	CANopen	Bus-OUT	Bus-IN	M12 A 4-pin male	M12 A 4-pin female
CX4040-0/CX404W-0	04	EtherNet/IP	Bus-IN	Bus-OUT	M12 D 4-pin female	M12 D 4-pin female
CX4050-0/CX405W-0	05	EtherCAT	Bus-IN	Bus-OUT	M12 D 4-pin female	M12 D 4-pin female
CX4060-0/CX406W-0	06	PROFINET	Bus-IN	Bus-OUT	M12 D 4-pin female	M12 D 4-pin female
CX4070-0/CX407W-0	07	I/O-link	Bus	-	M12 B 5-pin male	-

Multi-serial modules Cover



It is possible to configure a valve island using only the housing base of the Fieldbus cover, this allows to use the island with different Fieldbus types simply by integrating the relative cover.
 It is not possible to assemble an I/O-link cover on a Fieldbus base or a Fieldbus cover on an I/O-Link base.
 The position of the fixing screws on the front of the cover allows a quick installation or replacement.

The supply includes:
 1 cover
 5 fixing screws

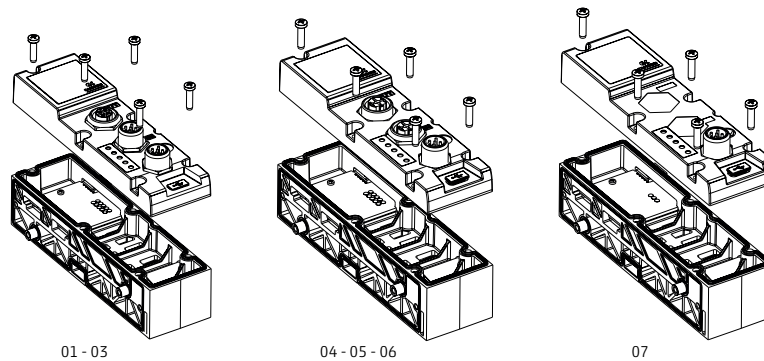

NO WLAN / WITH WLAN	Mod.	Fieldbus Protocol
CX4510-0/CX451W-0	01	PROFIBUS
CX4530-0/CX453W-0	03	CANopen
CX4540-0/CX454W-0	04	EtherNet/IP
CX4550-0/CX455W-0	05	EtherCAT
CX4560-0/CX456W-0	06	PROFINET
CX4570-0/CX457W-0	07	I/O LINK

Digital Input module Mod. ME4-0800-DC and ME4-1600-DT



The Digital input module can be connected at the left of the Multi-serial module and can be placed in any order with other, both digital and analog Input/Output modules.

The module integrates diagnostic functions and is available in versions with:

- Eight M8 3-pin connectors.
- Terminal block (Push-in) for the connection of 16 inputs

In the terminal block version, power supply is normally provided by the valve island directly.

In case of loads exceeding 800mA, power supply is provided by an external power supply to be connected to a 2-pin terminal block connector (PWR)

The supply includes 2 tie-rods.

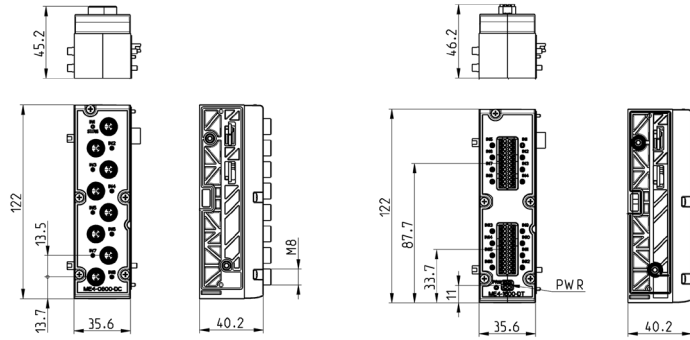

Mod.	Coding reference	Number of digital inputs	Connection	Number of connectors	Dimensions	Signalling	Sensor supply	Overvoltage protection	Absorption	Type of Protection signal	Protection class	Operating temperature	Weight
ME4-0800-DC	A	8	M8 3 pin female	8	122 x 35.6 mm	8 yellow led 1 red led	24 V DC	400 mA for 4 sensors	10 mA	PNP	IP65	0 + 50°C	110 g
ME4-1600-DT	B	16	2 terminal blocks 24 pin (push-in)	-	122 x 35.6 mm	8 yellow led 1 red led	24 V DC Internal: 800 mA for 16 sensors External: 2 A for 16 sensors	400 mA for 4 sensors	10 mA	PNP	IP20	0 + 50°C	110 g

Digital Input module Cover Mod. ME4-0800-DC and ME4-1600-DT



It is possible to configure a valve island with free electric positions.

You can integrate further electrical signals in a valve island by replacing the cover plate with the relative I/O cover.

The supply includes:
1 cover
5 fixing screws

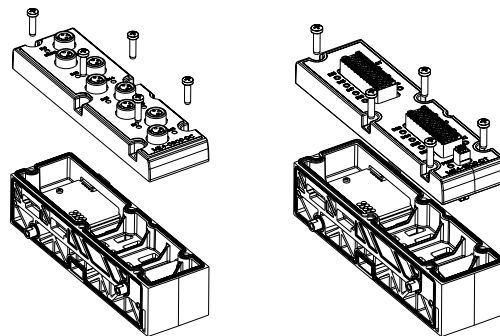

Mod.	Connection
ME4-0800-DC-C	M8 3-pin female
ME4-1600-DT-C	2 terminal blocks 24-pin (Push-in)

Digital output module Mod. ME4-0008-DC and ME4-0016-DT



The digital output module is connected on the left side of the Multi-serial module and can be positioned as desired with other both Digital and Analog I/O devices.

Available in two versions:

- 8 M8 3 pin connectors

- (Push-In) Terminal block for the connection of 16 outputs (8+8). The wire connection part is removable from the module.

For both versions, the outputs can be configured as PNP or NPN by means of a software UVIX.

(the standard version is configured as PNP)

The 8 output M8 version can supply 24W and is supplied directly by the valve island.

In the terminal block version, the power supply must always be supplied externally with 12-32V voltages, on the 2-pole connector. A maximum absorption of 48 W is possible.

The module is equipped with diagnostics (Status).

The supply includes 2 tie-rods.

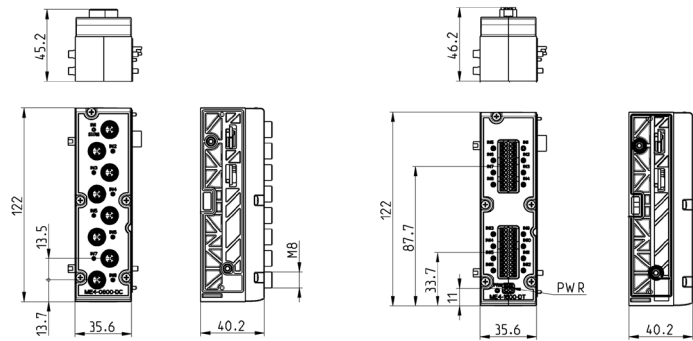

Mod.	Coding reference	N° of digital outputs	Connection	Number of connectors	Dimensions	Signalling	Supply outputs	Max current per module	Max power per digital output	Type of signal	Protection class	Operating temperature	Weight
ME4-0008-DC	Q	8	M8 3-pin female	8	122 x 35,6 mm	8 yellow led 1 red led	24 V DC	24 W	3 W	NPN/ PNP	IP65	0 ÷ 50°C	100 g
ME4-0016-DT	R	16	2 terminal blocks 24-pin (Push-in)	-	122 x 35,6 mm	8 yellow led 1 red led	12-32 V DC	48 W	3 W	NPN/ PNP	IP20	0 ÷ 50°C	100 g

Digital output module Cover Mod. ME4-0008-DC and ME4-0016-DT



It is possible to configure a valve island with free electric positions.

You can integrate further electrical signals in a valve island by replacing the cover plate with the relative I/O cover.

The supply includes:
1 cover
5 fixing screws

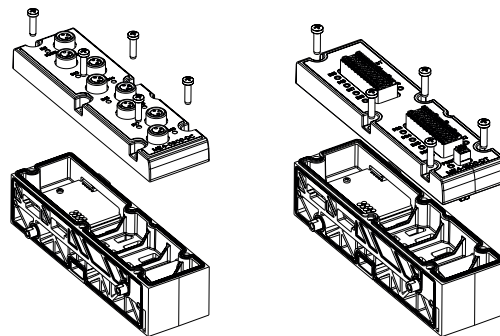

Mod.	Connection
ME4-0008-DC-C	M8 3-pin female
ME4-0016-DT-C	2 terminal blocks 24-pin (Push-in)

Analog input module Mod. ME4-C000-AL and ME4-C000-AT



The analog input module can be connected at the left of the CPU module and can be placed in any order with other Input/Output devices.

It is possible to configure every analog input as differential input 0-10V, ±10V, 0-20mA, 4-20mA, ±20mA with a resolution up to 16 bit.

External voltage of 24 V is available to supply the sensor connected (max 0,25A/channel). The output is protected against short-circuit.

The module is equipped with diagnostics (Status) and is available both in the version with two M12 connectors with 5 contacts, and in terminal block version with Push-in spring connection.

The supply includes 2 tie-rods.

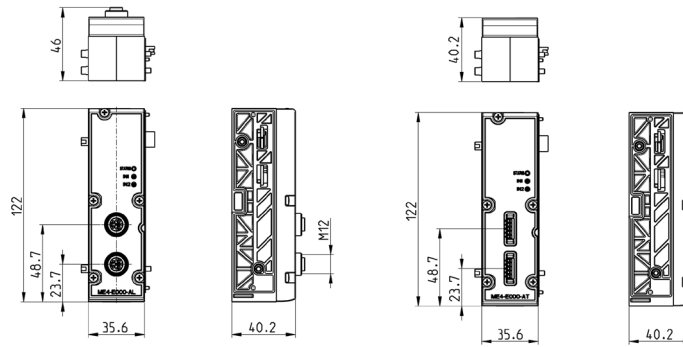

Mod.	Coding reference	Number of analog inputs	Connection	Number of connectors	Dimension	Signalling	Sensor supply	Overvoltage protection	Absorption	Protection class	Operating temperature	Weight
ME4-C000-AL	C	2 (Config. 0-10V,±10V,0-20mA,4-20mA,±20mA)	M12 A 5-pin female	2	122 x 35,6 mm	2 yellow led 1 red led	24 V DC	500 mA shared between the two channels	max 20 mA	IP65	0 ÷ 50°C	110 g
ME4-C000-AT	D	2 (Config. 0-10V,±10V,0-20mA,4-20mA,±20mA)	Terminal block 5-pin (Push-in)	2	122 x 35,6 mm	2 yellow led 1 red led	24 V DC	500 mA shared between the two channels	max 20 mA	IP20	0 ÷ 50°C	110 g

Analog input module Cover Mod. ME4-C000-AL and ME4-C000-AT



It is possible to configure a valve island with free electric positions.

You can integrate further electrical signals in a valve island by replacing the cover plate with the relative I/O cover.

The supply includes:
1 cover
5 fixing screws

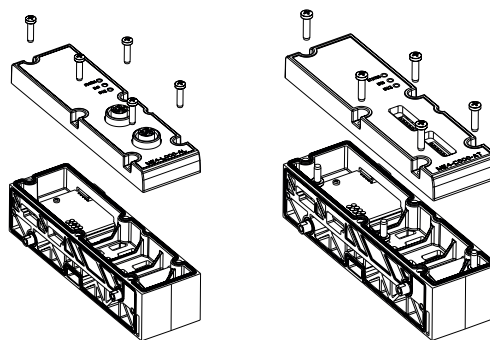

Mod.	Connection
ME4-C000-AL-C	M12 A 5-pin female
ME4-C000-AT-C	Terminal block 5-pin (Push-in)

Analog output module Mod. ME4-T000-AL and ME4-T000-AT



The analog output module can be connected at the left of the Multi serial module and can be placed in any order with other Input/Output devices.

It is possible to configure every analog output as 0-10V, 0-5V, 4-20mA, 0-20mA output with a resolution up to 16 bit.

External voltage of 24 V is available to supply the device connected (max 0,25A/channel). The output is protected against short-circuit.

The supply includes 2 tie-rods.

The module is equipped with diagnostics (Status) and is available both in the version with two M12 connectors with 5 contacts, and in terminal block version with Push-in spring connection.

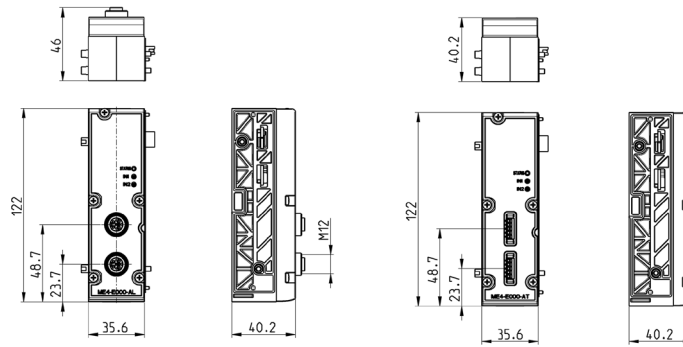

Mod.	Coding reference	Number of analog outputs	Connection	Number of connectors	Dimension	Signalling	Supplied externally	Overvoltage protection	Absorption	Protection class	Operating temperature	Weight
ME4-T000-AL	T	2 (Config. 0-10V,0-5V,0-20mA,4-20mA)	M12 A 5-pin female	2	122 x 35,6 mm	2 yellow led 1 red led	24 V DC	500 mA shared between the two channels	max 6 mA	IP65	0 ÷ 50°C	110 g
ME4-T000-AT	U	2 (Config. 0-10V,0-5V,0-20mA,4-20mA)	Terminal block 5-pin (Push-in)	2	122 x 35,6 mm	2 yellow led 1 red led	24 V DC	500 mA shared between the two channels	max 6 mA	IP20	0 ÷ 50°C	110 g

Analog output module Cover Mod. ME4-T000-AL and ME4-T000-AT



It is possible to configure a valve island with free electric positions. You can integrate further electrical signals in a valve island by replacing the cover plate with the relative I/O cover.

The supply includes:
1 cover
5 fixing screws

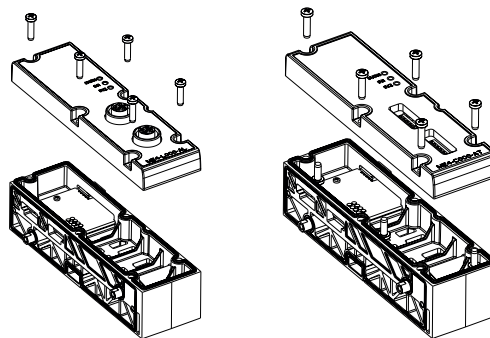

Mod.	Connection
ME4-T000-AL-C	M12 A 5-pin female
ME4-T000-AT-C	Terminal block 5-pin (Push-in)

Analog input module Mod. ME4-E000-A*, ME4-G000-A* and ME4-L000-A*



The analog input module can be connected at the left of the CPU module and can be placed in any order with other, both digital and analog Input/Output devices.

Analog, 2-channel Bridge module (ME4-E000-A*):

Sensor data acquisition module with Resistor Bridge-type (4-wire) output, like strain gauge, non isolated.

The module is able to process the two channel inputs with gain factor from 1mV/V to 255mV/V, with a resolution of up to 24bit.

Supply voltage of the sensor +5V (max 0,05A/channel). The output is protected against short-circuit.

Analog, 2-channel RTD module (ME4-G000-A*):

RTD Temperature sensor data acquisition module, in 2/3/4-wire configuration, non isolated.

The module is able to process the following sensor types:

PT100, PT200, PT500, PT1000, Ni100, Ni120, Ni1000, with a resolution of up to 16bit.

Typical measuring fields range from -200 ÷ +850 °C (PT sensors) and -60 ÷ +250 °C (Ni sensors)

Analog, 2-channel TC (thermocouples) module (ME4-L000-A*):

TC temperature sensor data acquisition module in 2-wire configuration, non isolated.

The module is able to process the following sensor types:

J, K, B, E, N, R, S, T, with a resolution of up to 16bit.

The supply includes 2 tie-rods.

All modules are equipped with diagnostics (Status).

The characteristics of the single input can be configured by a software for all analog module types.

The modules are available both in the version with two M12 connectors with 5 contacts, and in the terminal block version with Push-in spring connection.

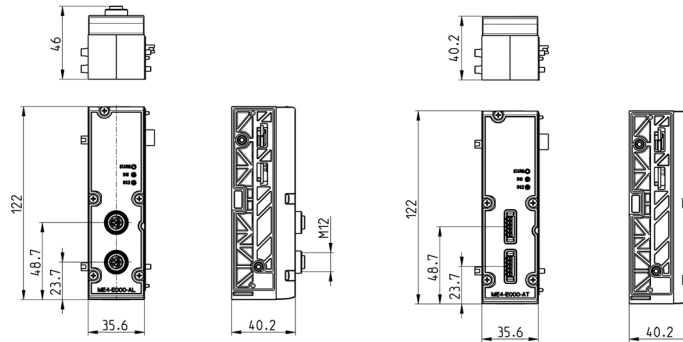

Mod.	Coding reference	Numbers of analog inputs	Connection	Number of connectors	Dimension	Signalling	Absorption	Protection class	Operating temperature	Weight
ME4-E000-AL	E	2 M12 bridge inputs	M12 A 5-pin female	2	122 x 35,6 mm	2 yellow led 1 red led	max 20 mA	IP65	0 ÷ 50°C	110 g
ME4-E000-AT	F	2 bridge inputs with terminal block (Push-in)	Terminal block (Push-in) 5-pin	2	122 x 35,6 mm	2 yellow led 1 red led	max 20 mA	IP20	0 ÷ 50°C	110 g
ME4-G000-AL	G	2 RTD M12 inputs	M12 A 5-pin female	2	122 x 35,6 mm	2 yellow led 1 red led	max 20 mA	IP65	0 ÷ 50°C	110 g
ME4-G000-AT	H	2 RTD inputs with terminal block (Push-in)	Terminal block (Push-in) 5-pin	2	122 x 35,6 mm	2 yellow led 1 red led	max 20 mA	IP20	0 ÷ 50°C	110 g
ME4-L000-AL	L	2 TC M12 inputs	M12 A 5-pin female	2	122 x 35,6 mm	2 yellow led 1 red led	max 20 mA	IP65	0 ÷ 50°C	110 g
ME4-L000-AT	M	2 TC inputs with terminal block (Push-in)	Terminal block (Push-in) 5-pin	2	122 x 35,6 mm	2 yellow led 1 red led	max 20 mA	IP20	0 ÷ 50°C	110 g

Analog input module Cover Mod. ME4-E000-A*, ME4-G000-A* and ME4-L000-A*



It is possible to configure a valve island with free electric positions.
You can integrate further electrical signals in a valve island by replacing the cover plate with the relative I/O cover.

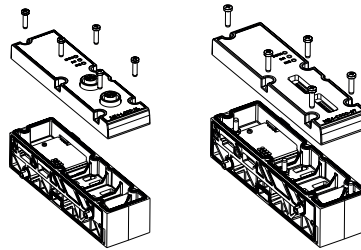

The supply includes:
1 cover
5 fixing screws

Mod.	Connection
ME4-E000-AL-C	M12 A 5-pin female
ME4-E000-AT-C	Terminal block (Push-in) 5-pin
ME4-G000-AL-C	M12 A 5-pin female
ME4-G000-AT-C	Terminal block (Push-in) 5-pin
ME4-L000-AL-C	M12 A 5-pin female
ME4-L000-AT-C	Terminal block (Push-in) 5-pin

Closed base without I/O cover

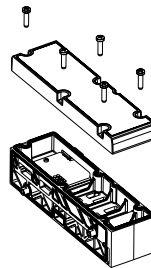

Mod.
ME4-0000-FP

Base without Fieldbus cover

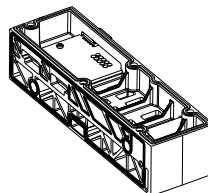

Mod.
CX4000-0

Tie-rods for valve size 2

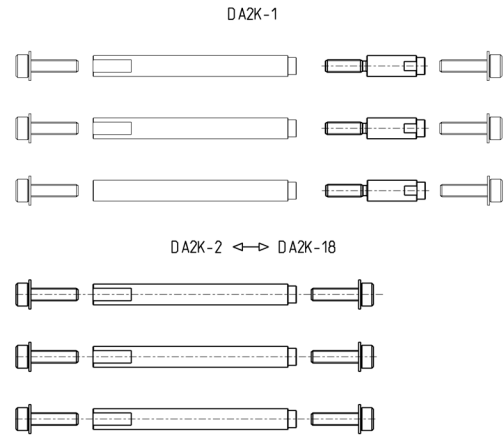

Mod.	Valve positions	NOTE
DA2K-1	-	**
DA2K-2	2	*
DA2K-4	4	*
DA2K-6	6	*
DA2K-8	8	*
DA2K-10	10	*
DA2K-12	12	*
DA2K-14	14	*
DA2K-16	16	*
DA2K-18	18	*
DA2K-20	20	*
...		
DA2K-64	64	***

* Tie-rod
The supply includes
3 tie-rods and 6 screws.

tie-rods and
6 screws

** Joint bolt
for odd positions.
The supply includes 3 joint bolts.

*** The supply includes a kit of

M12 male terminating resistor

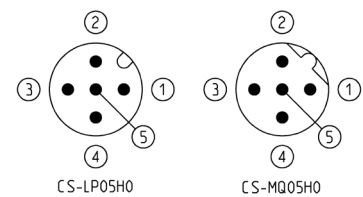
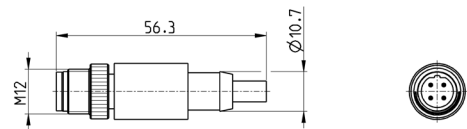

Mod.	description	type of connector	connection	Fieldbus
CS-MQ05H0	moulded terminating resistor	straight	M12 B 4 pin male - Pin 5 is not connected	PROFIBUS
CS-LP05H0	moulded terminating resistor	straight	M12 A 5 pin male - Pin 5 is connected	CANOpen

Straight connector for power supply

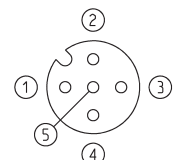
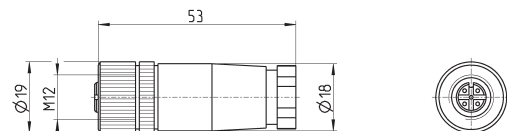

Mod.	description	type of connector	connection	cable length (m)
CS-LF04HB	for wiring	straight	M12 A 4 pin female - Pin 5 is not connected	-

Straight female M12 connectors for Bus-IN

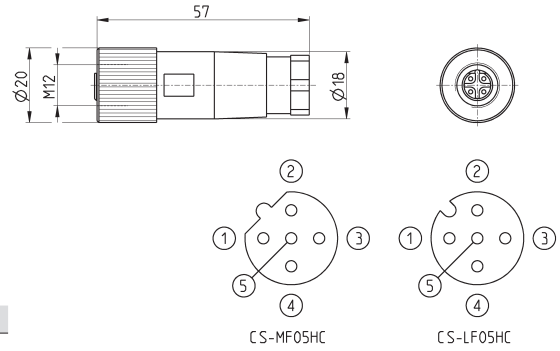

Mod.	description	type of connector	connection	Fieldbus
CS-LF05HC	for wiring	straight	M12 A 5 pin female	CANopen/IQ-Link
CS-MF05HC	for wiring	straight	M12 B 5 pin female	PROFIBUS

Male M12 connectors for Bus-OUT and I/O modules

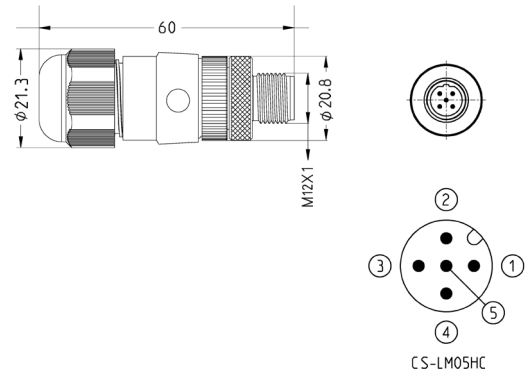

Mod.	description	type of connector	connection	Fieldbus
CS-LM05HC	for metal wiring	straight	M12 A 5 pin male	CANopen

Straight male M12 connectors for Bus-OUT PROFIBUS

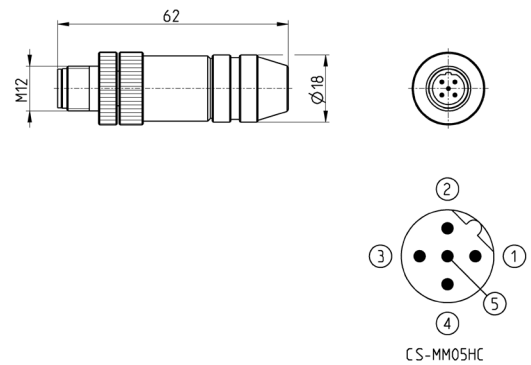

Mod.	description	type of connector	connection	Fieldbus
CS-MM05HC	for metal wiring	straight	M12 B 5 pin male	PROFIBUS

3 pin male M8 wiring connector for digital input modules

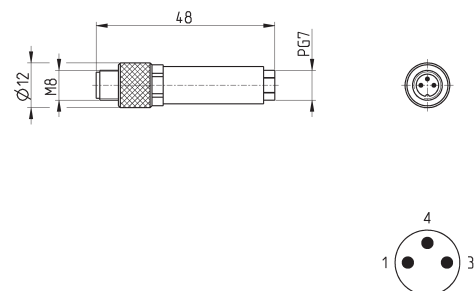

Mod.	description	type of connector	connection	cable length (m)
CS-DM03HB	for wiring	straight	M8 3 pin male	-

Male wiring connector for Bus-IN and Bus-OUT

For PROFINET, EtherCAT, EtherNet/IP

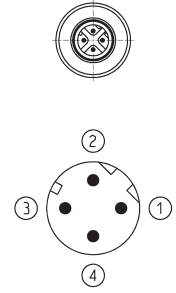
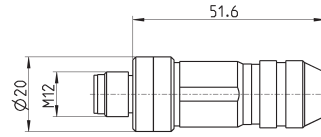

Mod.	description	type of connector	connection	cable length (m)
CS-SM04H0	for metal wiring	straight	M12 D 4 pin	-

Cable with M12 5 pin connector, female, shielded

For IO-Link power supply and signal

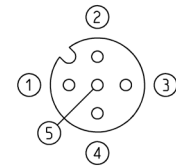
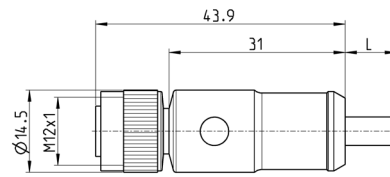

Mod.	Cable length (m)
CS-LF05HB-D200	2
CS-LF05HB-D500	5

Right angle Sub-D female connector 25-44 pins

Protection class IP65

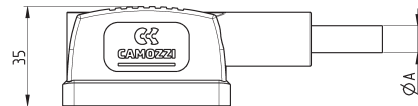
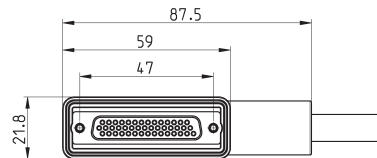

Mod.	mA	PIN	cable length (m)
G25X1-3	10	25	3
G25X1-5	10	25	5
G25X1-10	10	25	10
G25X1-15	10	25	15
G25X1-20	10	25	20
G25X1-25	10	25	25
G44X1-3	13	44	3
G44X1-5	13	44	5
G44X1-10	13	44	10
G44X1-15	13	44	15
G44X1-20	13	44	20
G44X1-25	13	44	25

Adaptor and panel mount for Ethernet RJ45 to M12 D networks

For PROFINET, EtherCAT, EtherNet/IP

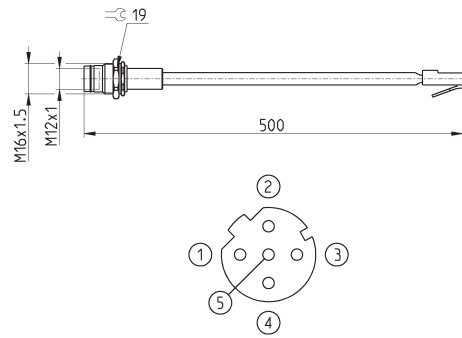

Mod.	description	type of connector	connection	cable length (m)
CS-SE04HB-F050	moulded cable	straight	RJ45 male, M12 D 4 pin female - Pin 5 is not connected	0.5

Extension with M8 connector, 3 pin male/female

Non shielded

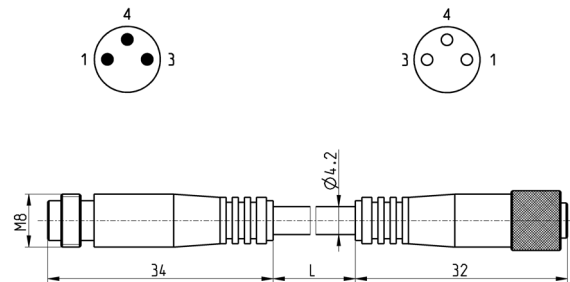

Mod.	description	type of connector	connection	L [cable length] (m)
CS-DW03HB-C250	moulded cable	straight	M8 3 pin male / female	2.5
CS-DW03HB-C500	moulded cable	straight	M8 3 pin male / female	5

USB to Micro USB cable Mod. G11W-G12W-2

For the hardware configuration of the Camozzi products

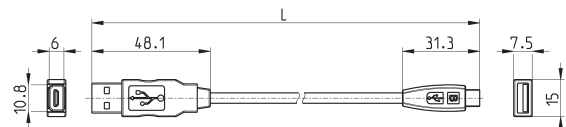

Mod.	description	connections	material for outer sheath	cable length "L" (m)
G11W-G12W-2	black shielded cable 28 AWG	standard USB to Micro USB	PVC	2

Adapter cable, M8 3-pin male - M12 4-pin female

Protection class: IP69K

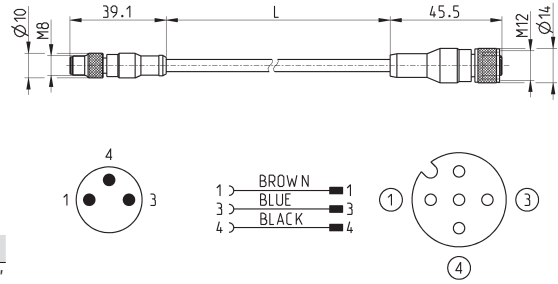

Mod.	description	max voltage	max current	Nr conn. wires	connections	outer sheath	cable "L" (m)
CS-AG03HB-C250	3-pin cable 24 AWG, high flexibility	50V AC / 60V DC	3 A	3	M8 3-pin male - M12 4-pin fem.	PUR black	2.5
CS-AG03HB-C500	3-pin cable 24 AWG, high flexibility	50V AC / 60V DC	3 A	3	M8 3-pin male - M12 4-pin fem.	PUR black	5

Cables with straight connectors

For PROFINET, EtherCAT, EtherNet/IP

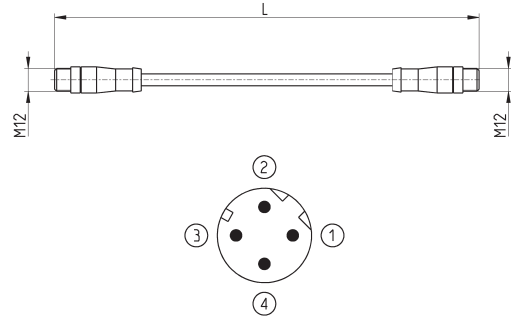

Mod.	description	type of connector	connection	L [cable length] (m)
CS-SB04HB-D100	moulded cable	straight	2x M12 D 4 pin male	1
CS-SB04HB-D500	moulded cable	straight	2x M12 D 4 pin male	5
CS-SB04HB-DA00	moulded cable	straight	2x M12 D 4 pin male	10
CS-SB04HB-DD00	moulded cable	straight	2x M12 D 4 pin male	15
CS-SB04HB-DG00	moulded cable	straight	2x M12 D 4 pin male	20
CS-SB04HB-DJ00	moulded cable	straight	2x M12 D 4 pin male	25

Interchangeable cartridges for subbases and terminal plates/diaphragms



TABLE LEGEND:

✘ = compatible with
VS = subbase version
VT = terminal plate/diaphragm version

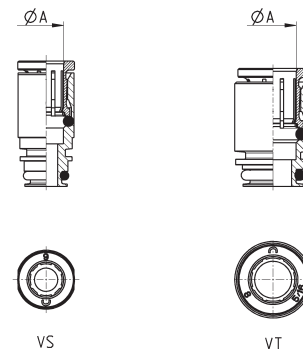

Mod.	ØA	VS	VT
6700 6-D2	6	✘	
6700 8-D2	8	✘	
6700 10-D2/1	10	✘	
6700 10-D2	10		✘
6700 12-D2	12		✘
6700 14-D2	14		✘
6700 04-D2	1/4	✘	
6700 05-D2	3/8	✘	
6700 06-D2	1/2		✘
6700 08-D2	5/16		✘

M8 and M12 connector cover caps



For digital and analog input/output modules and subnet

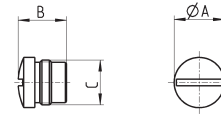

Mod.	A	B	C [Connection]
CS-DFTP	10	11	M8
CS-LFTP	13.5	13	M12

Identification plates



The packaging contains
45 identification plates 9x5mm

Mod.
HP1/E

Mounting brackets for DIN rail



DIN EN 50022 (mm 7,5 x 35 - width 1)

Supplied with:
2x plates
2x screws M4x8 UNI 5931

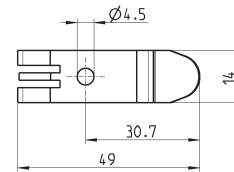
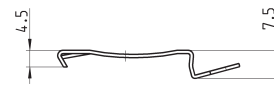

Mod.
PCF-D1