



High energy absorption cylinder HCM Series

● : Standard, ◎ : Option, ■ : Not available

Variation	Model no. JIS symbol	Bore size (mm)	Standard stroke length (mm)																Min. stroke length (mm) Note 1	Max. stroke length (mm)	Custom stroke length (per mm)	Mounting style				Cushion				Option		Accessory		Switch	Page	
			200	250	300	350	400	450	500	550	600	650	700	750	800	850	900	950				1000	Basic type	Axial foot type	Rod end flange type	Head end flange type	Both sides cushioned	Rod end cushion	Head end cushion	No cushion	Switch rail attached at shipment	Piston rod material (stainless steel)	Rod eye			Rod clevis
Double acting single rod type	HCM 	φ20, φ25, φ32	●	●	●	●	●	●	●	●	●	●	■	■	■	■	■	■	■	1	700	1	●	●	●	●	●	●	●	●	◎	◎	◎	◎	◎	1960
		φ40, φ50, φ63	●	●	●	●	●	●	●	●	●	●	●	●	●	●	●	●	●	●	1	1000	1	●	●	●	●	●	●	●	●	◎	◎	◎	◎	

High speed cylinder HCA Series

● : Standard, ◎ : Option, ■ : Not available

Variation	Model no. JIS symbol	Bore size (mm)	Standard stroke length (mm)												Stroke length (mm)				Min. stroke length (mm) Note 1	Max. stroke length (mm)	Custom stroke length (mm)	Mounting style				Cushion				Switch	Page		
			400	450	500	550	600	650	700	750	800	850	900	950	1000	Basic type	Axial foot type	Rod end flange type				Head end flange type	Both sides cushioned	Rod end cushion	Head end cushion	No cushion							
Double acting single rod type	HCA 	φ20, φ25, φ32	●	●	●	●	●	●	●	■	■	■	■	■	■	■	■	1	700	1	●	●	●	●	●	●	●	●	◎	◎	◎	◎	1978
		φ40, φ50, φ63 φ80, φ100	●	●	●	●	●	●	●	●	●	●	●	●	●	●	●	●	1	1000	1	●	●	●	●	●	●	●	●	◎	◎	◎	

Note: Bore size 25, 63, 80, and 100 are custom orders.

Note 1: The stroke is available from 1mm. However, this product's cushion area is longer than a typical cylinder so that a high energy can be absorbed. Thus, the cushion is applied in the following strokes, and an effect for use at a high-speed will not be achieved.

Model no.	Stroke which effect of high-speed cannot be anticipated	Recommended stroke length
HCM	150mm mm stroke or less	300mm stroke and over
HCA	200mm mm stroke or less	400mm stroke and over

HCA

High speed cylinder

ϕ 20, ϕ 25, ϕ 32, ϕ 40
 ϕ 50, ϕ 63, ϕ 80, ϕ 100

High-speed type

Overview

This is high speed (3000mm/s) and high energy absorbing cylinder. This can be used for ejecting model such as resin etc.



CONTENTS

Series variation	1952
Variation and option selection table	1976
▲ Safety precautions	1977
● Double acting single rod type (HCA)	1978
Selection guide	1988

Product introduction

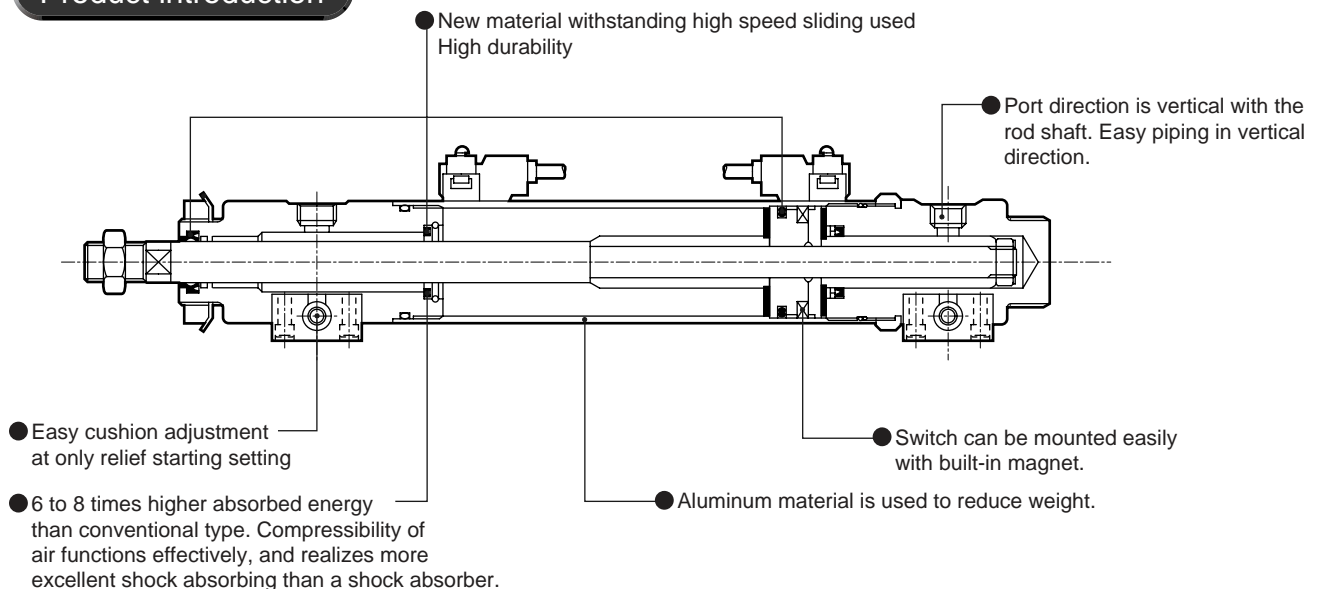

SCP*2
CMK2
CMA2
SCM
SCG
SCA2
SCS
CKV2
CA/OV2
SSD
CAT
MDC2
MVC
SMD2
MSD*
FC*
STK
ULK*
JSK/M2
JSG
JSC3
USSD
USC
JSB3
LMB
STG
STS/L
LCS
LCG
LCM
LCT
LCY
STR2
UCA2
HCM
HCA
SRL2
SRG
SRM
SRT
MRL2
MRG2
SM-25
CAC3
UCAC
RCC2
MFC
SHC
GLC
Ending

High speed cylinder
High-speed type



Pneumatic components

Safety precautions

Always read this section before starting use.

Refer to Intro 71 for general precautions of the cylinder, and to Intro 78 for general precautions of the cylinder switch.

SCP*2
CMK2
CMA2
SCM
SCG
SCA2
SCS
CKV2
CA/OV2
SSD
CAT
MDC2
MVC
SMD2
MSD*
FC*
STK
ULK*
JSK/M2
JSG
JSC3
USSD
USC
JSB3
LMB
STG
STS/L
LCS
LCG
LCM
LCT
LCY
STR2
UCA2
HCM
HCA
SRL2
SRG
SRM
SRT
MRL2
MRG2
SM-25
CAC3
UCAC
RCC2
MFC
SHC
GLC
Ending

High speed cylinder
High-speed type

High speed cylinder HCA Series

Design & Selection

CAUTION

- Avoid applying a lateral load to the cylinder piston rod. The required speed may not be attained, bearings may wear abnormally, and performance may drop.
- Cushion
The air cushion absorbs kinetic energy the piston generates using air compressibility and prevents the piston and cover from colliding at the stroke limit. The cushion is not used to decelerate the piston near the stroke limit.

- The cylinder system selection guide differs with working conditions (working pressure, load movement direction/method, and piping length) and is for reference only.
- If the cylinder is moved at high speed, the instantaneous airflow increases and causes drain, etc., to accumulate easily. Provide an air tank to prevent drain from entering the cylinder and to prevent pressure loss when filtering oil mist.

Installation & Adjustment

CAUTION

- The cylinder is designed to be used high speed. A JISB1554 nut (lock nut, washer, and fitting for rolling bearings) is used to install the main unit so it will not loosen. Use the following hook spanner when fixing mounting brackets on the main unit, and when loosening the lock nut to disassemble the main unit.

(1) Fixing mounting brackets on the main unit

Model no. Descriptions	HCA-20	HCA-25	HCA-32	HCA-40
Working nut	AN05	AN05	AN05	AN07
Applicable hook spanners	Nominal 34-38	Nominal 34-38	Nominal 34-38	Nominal 45-50
Model no. Descriptions	HCA-50	HCA-63	HCA-80	HCA-100
Working nut	AN08	AN08	AN12	AN12
Applicable hook spanners	Nominal 52-55	Nominal 58-62	Nominal 80-90	Nominal 80-90

(2) Tightening the main unit's lock nut

Model no. Descriptions	HCA-20	HCA-25	HCA-32	HCA-40
Applicable hook spanners			Nominal 34-48	Nominal 45-50
Wrench	Nominal 30	Nominal 35		
Model no. Descriptions	HCA-50	HCA-63	HCA-80	HCA-100
Applicable hook spanners	Nominal 52-55	Nominal 68-75	Nominal 80-90	Nominal 110-115
Wrench				

- The maximum speed for the working piston is 3000mm/s, which is not the average speed.
- The cylinder main unit restriction is designed for a speed of 3000mm/s or more, and should not be restricted with piping, valves, or flow control valves.
- When adjusting speed with the speed control valve, gradually open the needle from closed and raise speed. The piston rod may suddenly pop out and create a hazard if speed is adjusted while the needle is open.
- The piston rod may pop out if operation is started while the exhaust side is at atmospheric pressure. Pressurize the exhaust side before starting.
- Install the speed control valve cylinder piping port near. Otherwise, speed cannot be controlled.
- Provide a separate shock absorber if the specifications (allowable energy absorption) are exceeded.

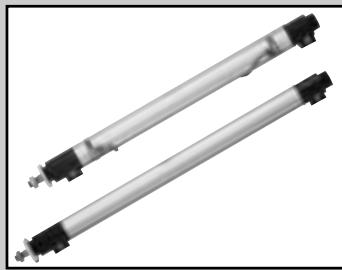

High speed cylinder Double acting single rod type

HCA Series

● Bore size: $\phi 20$, $\phi 25$, $\phi 32$, $\phi 40$, $\phi 50$, $\phi 63$, $\phi 80$, $\phi 100$

JIS symbol



Specifications

Descriptions		HCA (standard type with switch)							
Bore size	mm	$\phi 20$	$\phi 25$	$\phi 32$	$\phi 40$	$\phi 50$	$\phi 63$	$\phi 80$	$\phi 100$
Actuation		Double acting							
Working fluid		Compressed air							
Max. working pressure	MPa	1.0							
Min. working pressure	MPa	0.1							
Withstanding pressure	MPa	1.6							
Ambient temperature	°C	-10 to 60 (no freezing)							
Port size		Rc1/8		Rc1/4		Rc3/8		Rc1/2	
Stroke tolerance	mm	$+^{2.4}_0$	$+^{3.6}_0$	$+^{4.3}_0$			$+^{5.0}_0$		
Working piston speed	mm/s	50 to 3000							
Cushion		Air cushion							
Lubrication		Not required (when lubricating, use turbine oil Class 1 ISOVG 32)							
Allowable energy absorption J	Cushioned	7.54	11.8	18.6	29.4	46.1	73.5	118	184
	No cushion	A large energy generated by an external load can not be absorbed. So an external shock absorber should be used.							
Effective cushion length	mm	85	75	70	70	70	70	70	70

Note 1: Bore size (mm) 25, 63, 80, and 100 are custom orders.
 Note 2: Refer to page 1990 for the absorbed energy.

Stroke length

Bore size (mm)	Stroke length (mm)	Max. stroke length (mm)	Min. stroke length (mm)
$\phi 20$, $\phi 25$, $\phi 32$	400 to 700	700	1
$\phi 40$, $\phi 50$, $\phi 63$, $\phi 80$, $\phi 100$	400 to 1000	1000	

Note 1: Custom stroke length is available per 1mm increment.
 Note 2: Stroke length exceeded maximum stroke length is manufactured depending on working conditions. Consult CKD.
 Note 3: For types with switch, minimum stroke length varies depending on installation method. Refer to the table below.
 Note 4: The stroke is available from 1mm. However, this product's cushion area is longer than a typical cylinder so that a high energy can be absorbed. Thus, the cushion is applied in the following strokes, and an effect for use at a high-speed will not be achieved.

Model no.	Stroke at which effect of high-speed cannot be anticipated	Recommended stroke
HCA	Stroke length 200mm or less	Stroke length 400mm and over

Min. stroke length of types with switch

Rough sketch	Different surface installation		Same surface installation	
Descriptions	Grommet	Terminal box	Grommet	Terminal box
$\phi 20$ to $\phi 100$	15 (10) mm	15 (10) mm	30mm	32mm (installation A) 80mm (installation B)

● Note 1: The value in () is for the type with a switch.

SCP*2
CMK2
CMA2
SCM
SCG
SCA2
SCS
CKV2
CA/OV2
SSD
CAT
MDC2
MVC
SMD2
MSD*
FC*
STK
ULK*
JSK/M2
JSG
JSC3
USSD
USC
JSB3
LMB
STG
STS/L
LCS
LCG
LCM
LCT
LCY
STR2
UCA2
HCM
HCA
SRL2
SRG
SRM
SRT
MRL2
MRG2
SM-25
CAC3
UCAC
RCC2
MFC
SHC
GLC
Ending

Switch specifications

Descriptions	Proximity switch				
	R1	R2	R2Y (2 color indicator type)	R3	R3Y (2 color indicator type)
Applications	Programmable controller, relay, small solenoid valve	Programmable controller, relay		Programmable controller, relay, IC circuit, solenoid valve	
Output method	—————			NPN output	
Power voltage	—————	—————	4.5V to 28 VDC		
Load voltage/current	85V to 265 VAC 5 to 100mA	10 to 30 VDC 5 to 30mA		30 VDC or less 200mA or less DC	
Light	LED (ON lighting)		Red/green LED (ON lighting)	LED (ON lighting)	Red/green LED (ON lighting)
Leakage current	1mA or less with 100 VAC 2mA or less with 200 VAC	1mA or less	1.2mA or less	10 μA or less	

Descriptions	Reed switch			
	R0	R4	R5	R6
Applications	Relay, programmable controller	High capacity relay, solenoid valve	Programmable controller, relay, IC circuit (w/o light), serial connection	Programmable controller (with DC self hold)
Load voltage/current	12/24 VDC, 5 to 50mA 110 VAC, 7 to 20mA 220 VAC, 7 to 10mA	110 VAC, 20 to 200mA 220 VAC, 10 to 200mA	5/12/24 VDC, 50mA or less 110 VAC, 20mA or less 220 VAC, 10mA or less	24 VDC, 5 to 50mA
Light	LED ON lighting	Neon light OFF lighting	None	LED ON lighting
Leakage current	0mA	1mA or less	0mA	0.1mA or less

Note 1: Refer to Ending 1 for other switch specifications.

Cylinder weight

(Unit: kg)

Bore size (mm)	Product weight when stroke length S = 0mm			Weight per switch (Including mounting bracket)		S=100mm
	Basic type (00)	Foot type (LB)	Flange type (FA/FB)	Grommet lead	Terminal box	
				0.04	0.03	
φ 20	0.73	0.91	0.80	0.04	0.03	0.11
φ 25	0.80	0.98	0.87	0.04	0.03	0.14
φ 32	0.85	1.03	0.92	0.04	0.03	0.16
φ 40	1.37	1.63	1.69	0.04	0.03	0.27
φ 50	2.13	2.56	2.50	0.04	0.03	0.34
φ 63	3.17	3.88	3.81	0.04	0.03	0.42
φ 80	5.75	7.27	7.12	0.04	0.03	0.67
φ 100	7.92	9.94	9.75	0.04	0.03	0.91

(E.g.) Product weight of HCA-00-40B-500-R0-D

- Product weight when stroke length 0mm: 1.37kg + 2 x 0.04kg = 1.45kg
- Additional weight when stroke length 500mm: 0.27 x $\frac{500}{100}$ = 1.35kg
- Product weight: 1.45 + 1.35 = 2.80kg

High speed cylinder
High-speed type

How to order

Without switch

HCA - **00** - **20** - **B** - **400** - **I**

With switch

HCA - **00** - **20** - **B** - **400** - **R0** - **R** - **I**

A Mounting style
Note 1

B Bore size

C Port thread type

D Cushion

E Stroke length

F Switch model no.

G Switch quantity

H Accessory

Note on model no. selection

Note 1: Mounting bracket, nut, and toothed washer are attached to product, when shipping.

(Example of model number)

HCA-00-20B-400-R0-R-I

Model: High speed cylinder double acting single rod type

- A** Mounting style : Basic type
- B** Bore size : ϕ 20mm
- C** Port thread type : Rc thread
- D** Cushion : Both sides cushioned
- E** Stroke length : 400mm
- F** Switch model no. : Reed R0 switch, lead wire 1m
- G** Switch quantity : One on rod end
- H** Accessory : Rod eye

Symbol	Descriptions
A Mounting style	
00	Basic type (00)
LB	Axial foot type
FA	Rod end flange type
FB	Head end flange type

B Bore size (mm)	
20	ϕ 20
25	ϕ 25 (custom order)
32	ϕ 32
40	ϕ 40
50	ϕ 50
63	ϕ 63 (custom order)
80	ϕ 80 (custom order)
100	ϕ 100 (custom order)

C Port thread type	
Blank	Rc thread
N	NPT thread (custom order)
G	G thread (custom order)

D Cushion	
B	Both sides cushioned
R	Rod end cushion
H	Head end cushion
N	No cushion

E Stroke length (mm)		
Bore size	Stroke length	Custom stroke length
ϕ 20 to ϕ 32	1 to 700	1 mm increment
ϕ 40 to ϕ 100	1 to 1000	

F Switch model no.					
Grommet type	Terminal box type		Contact	Indicator	Lead wire
	Standard type	Splash-proof			
R1*	R1B	R1A	Proximity	1 color indicator type	2-wire
R2*	R2B	R2A			
R2Y*	R2YB	R2YA	Proximity	2 color indicator type	2-wire
R3Y*	R3YB	R3YA			
R3*	R3B	R3A	Reed	1 color indicator type	3-wire
R0*	R0B	R0A		1 color indicator type	
R4*	R4B	R4A	Reed	1 color indicator type	2-wire
R5*	R5B	R5A		Without indicator light	
R6*	R6B	R6A	Reed	1 color indicator type	

*Lead wire length	
Blank	1m (standard)
3	3m (option)
5	5m (option)

G Switch quantity	
R	One on rod end
H	One on head end
D	Two
T	Three

H Accessory	
I	Rod eye
Y	Rod clevis (pin and snap ring attached)

How to order switch

● Switch body + mounting bracket

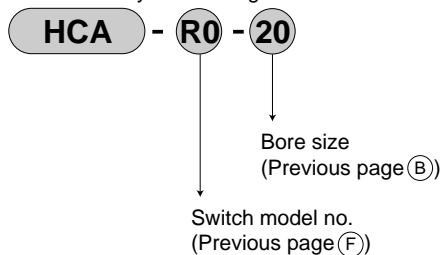

● Only switch body

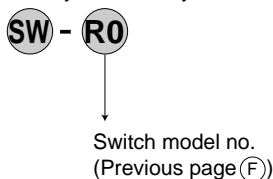

● Mounting bracket

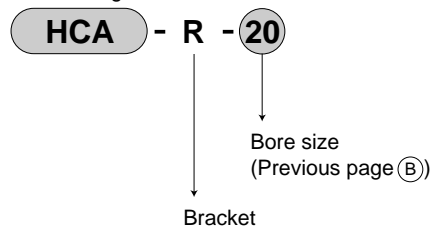

● Only terminal box

· R*B



· R*A



How to order mounting bracket

Bore size (mm)	20	25	32	40	50	63	80	100
Mounting bracket								
Foot (LB)	HCA-LB-20	HCA-LB-25	HCA-LB-32	HCA-LB-40	HCA-LB-50	HCA-LB-63	HCA-LB-80	HCA-LB-100
Flange (FA/FB)	HCA-FA-20	HCA-FA-25	HCA-FA-32	HCA-FA-40	HCA-FA-50	HCA-FA-63	HCA-FA-80	HCA-FA-100

Note 1: The foot type mounting bracket is provided as 2 pcs./set.

SCP*2
CMK2
CMA2
SCM
SCG
SCA2
SCS
CKV2
CA/OV2
SSD
CAT
MDC2
MVC
SMD2
MSD*
FC*
STK
ULK*
JSK/M2
JSG
JSC3
USSD
USC
JSB3
LMB
STG
STS/L
LCS
LCG
LCM
LCT
LCY
STR2
UCA2
HCM
HCA
SRL2
SRG
SRM
SRT
MRL2
MRG2
SM-25
CAC3
UCAC
RCC2
MFC
SHC
GLC
Ending

High speed cylinder
High-speed type

Internal structure and parts list

● HCA

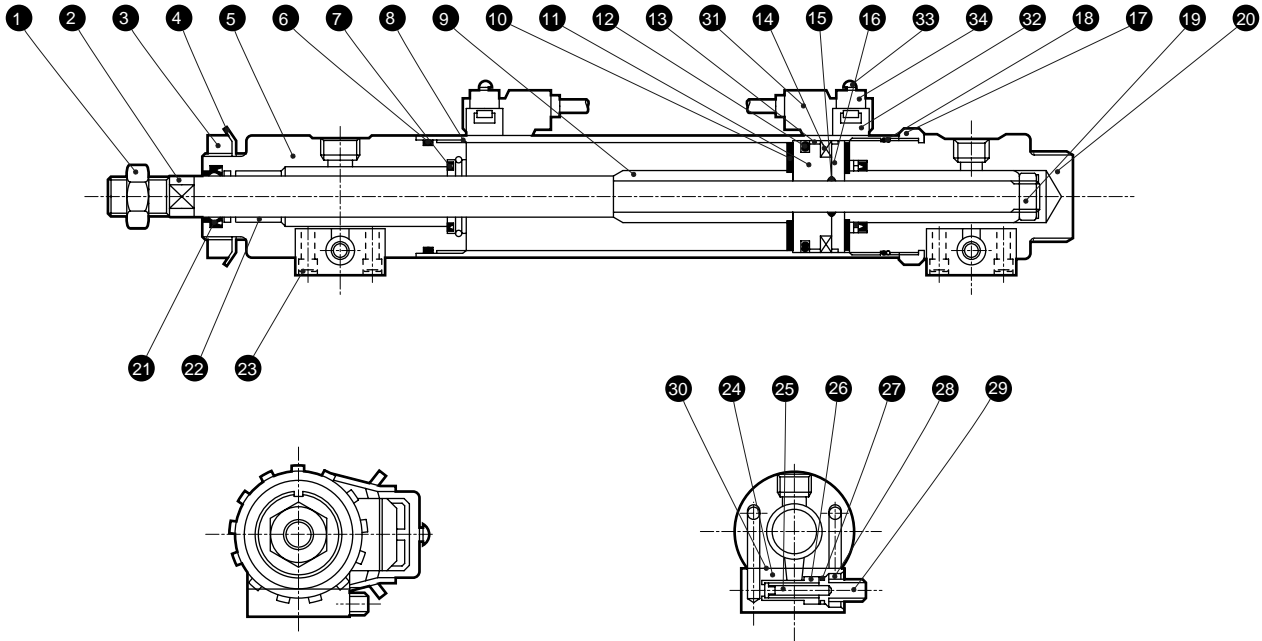

Note: The shape differs slightly only for the $\phi 20$ type.

No.	Parts name	Material	Remarks	No.	Parts name	Material	Remarks
1	Rod nut	Steel	Zinc chromate	19	Piston nut	Steel	Zinc chromate
2	Piston rod	Steel	Industrial chrome plating	20	Head cover	Aluminum alloy	Alumite
3	Nut	Steel	Galvanizing	21	Rod packing seal	Nitrile rubber	
4	The toothed washer	Steel	Galvanizing	22	Bush	Oil impregnated bearing alloy	
5	Rod cover	Aluminum alloy	Alumite	23	Hexagon socket head cap bolt	Alloy steel	Blackening
6	Cylinder gasket	Nitrile rubber		24	Adjuster case	Aluminum alloy	Alumite
7	Cushion packing seal	Urethane and steel		25	Check valve	Copper alloy	
8	Cylinder tube	Aluminum alloy	Hard alumite	26	Spring	Stainless steel	
9	Cushion ring	Steel	Industrial chrome plating	27	Adjusting gasket	Nitrile rubber	
10	Cushion rubber	Urethane rubber		28	U nut	Steel	Zinc chromate
11	Piston	Aluminum alloy	Chromate	29	Adjusting bolt	Steel	Nickeling
12	Piston packing seal	Nitrile rubber		30	Case gasket	Special fiber cloth	Special fiber + NBR
13	Wear ring	Acetar resin		With switch			
14	Magnet	Plastic		31	Switch body		
15	Piston gasket	Nitrile rubber		32	Band	Stainless steel	
16	Piston holder	Aluminum alloy	Chromate	33	Pan head machine screw	Steel	
17	Lock nut	Steel	Black chrome plating	34	Bracket	Stainless steel	
18	Back up ring	Steel	Zinc chromate				

Repair parts list

Bore size (mm)	Kit No.	Repair parts number
$\phi 20$	HCA-20K	
$\phi 25$	HCA-25K	
$\phi 32$	HCA-32K	
$\phi 40$	HCA-40K	6 7 10 12 13
$\phi 50$	HCA-50K	21 30
$\phi 63$	HCA-63K	
$\phi 80$	HCA-80K	
$\phi 100$	HCA-100K	

Note: Specify the kit No. when placing an order.

Mounting bracket material

Mounting style	Material	Remarks
LB	Steel	Galvanizing
FA/FB	Steel	Galvanizing

Dimensions

● HCA basic (00) R types with switch



φ 20, φ 25

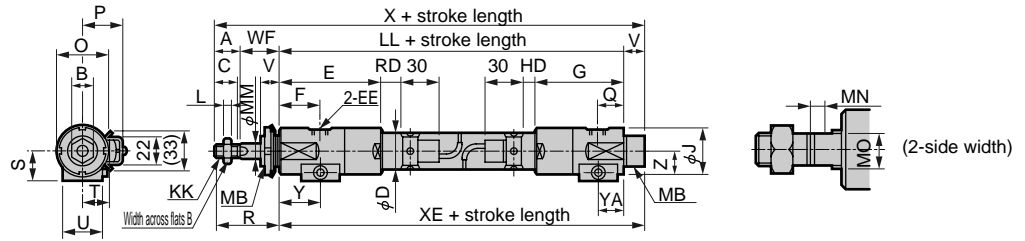

φ 32 to φ 63

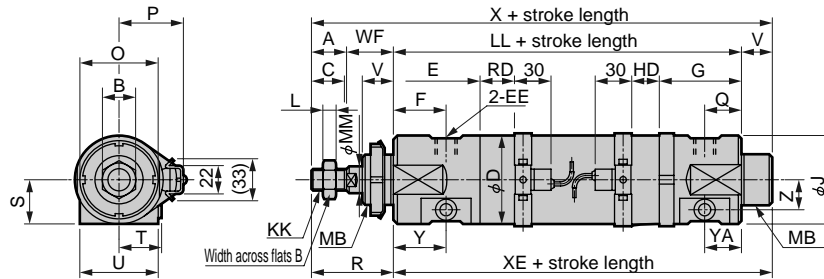

φ 80, φ 100

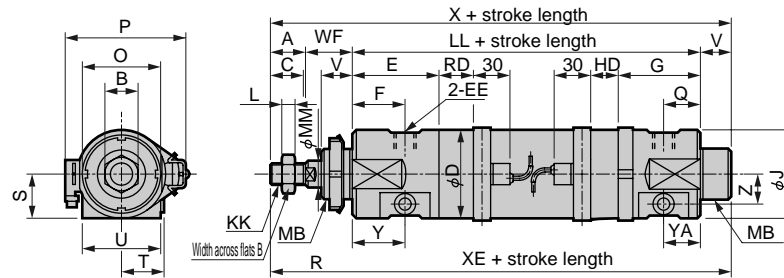

● R type switch terminal box

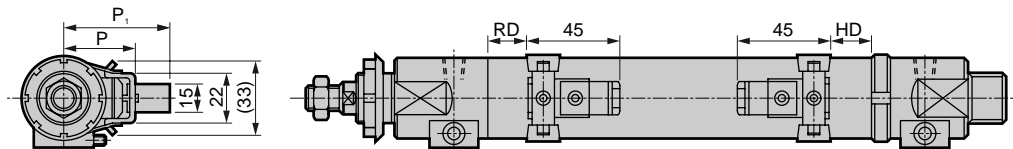

Note 1: Refer to page 1987 for dimensions of accessory.

Symbol	Basic type (00) basic dimensions																	
Bore size (mm)	A	B	C	D	E	EE	F	G	J	KK	L	LL	MB	MM	MN	MO	O	Q
φ 20	20	13	18	25	86	Rc1/8	34	74	33	M8 x 1	5	223	M25 x 1.5	10	4	8	42	22
φ 25	20	17	18	30	82	Rc1/8	32.5	71	37	M10 x 1.25	6	213	M25 x 1.5	12	5	10	42	21.5
φ 32	22	17	20	37	67	Rc1/4	42	57	37	M10 x 1.25	6	197	M25 x 1.5	12	5	10	42	25
φ 40	22	22	20	46	73	Rc1/4	45.5	57	46	M14 x 1.5	8	203	M35 x 1.5	16	6	14	57	25
φ 50	28	27	26	56.4	77	Rc3/8	47.5	60	56	M18 x 1.5	11	211	M40 x 1.5	20	7	17	62	24.5
φ 63	28	27	26	69.4	69	Rc3/8	42	65	69.4	M18 x 1.5	11	214	M40 x 1.5	20	7	17	62	29
φ 80	36	32	34	88	73	Rc1/2	45	70	88	M22 x 1.5	13	232	M60 x 2	25	10	22	86	31.5
φ 100	45	41	43	108	72	Rc1/2	42	72	108	M26 x 1.5	16	235	M60 x 2	30	11	27	86	30
Symbol	Basic type (00) basic dimensions													With switch				
Bore size (mm)	R	S	T	U	V	WF	X	XE	Y	YA	Z	HD	P	P ₁	RD			
φ 20	44	21.5	17 to 20	29	16	24	283	239	34	22	15	15.5	28	48	17.5			
φ 25	52	23.5	18.5 to 22	32	16	32	281	229	32.5	21.5	17	13	34	54	14.5			
φ 32	52	23.5	18.5 to 22	32	20	30	269	217	42	25	17	22	35	55	21			
φ 40	54	28.5	22 to 27	38	20	32	277	223	45.5	25	21	22	39	59	21			
φ 50	61	35.5	27 to 34.5	48	20	33	292	231	47.5	24.5	25.5	19	44	64	25			
φ 63	66	35.7	34 to 43	62	25	38	305	239	42	29	25.7	21	52	72	28			
φ 80	78	46.5	41 to 51	76	25	42	335	257	45	31.5	34.5	24.5	114	134	33.5			
φ 100	93	55.5	48 to 60	90	30	48	358	265	42	30	43.5	25	134	154	35			

SCP*2
CMK2
CMA2
SCM
SCG
SCA2
SCS
CKV2
CA/OV2
SSD
CAT
MDC2
MVC
SMD2
MSD*
FC*
STK
ULK*
JSK/M2
JSG
JSC3
USSD
USC
JSB3
LMB
STG
STS/L
LCS
LCG
LCM
LCT
LCY
STR2
UCA2
HCM
HCA
SRL2
SRG
SRM
SRT
MRL2
MRG2
SM-25
CAC3
UCAC
RCC2
MFC
SHC
GLC

Ending
High speed cylinder
High-speed type



Dimensions

● Axial foot type (LB)

φ20, φ25

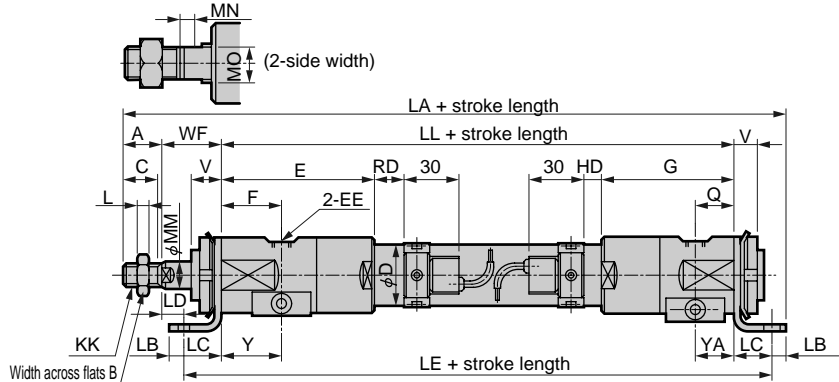
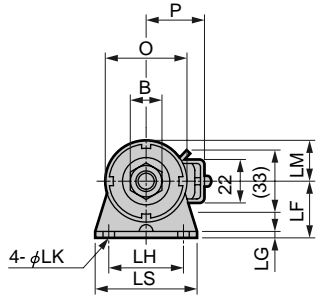

φ32 to φ63

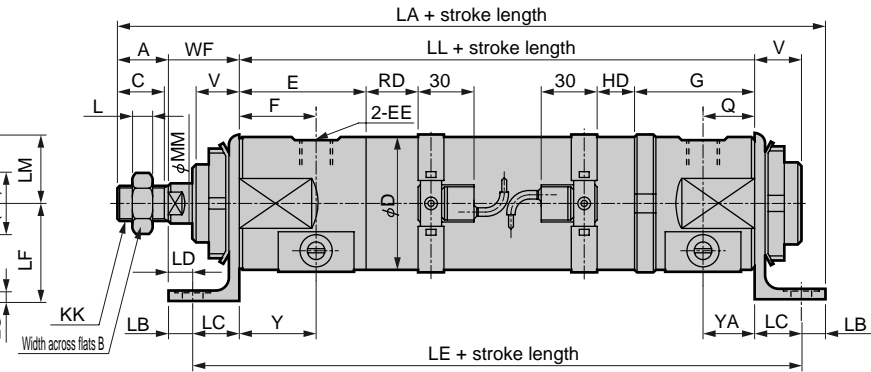
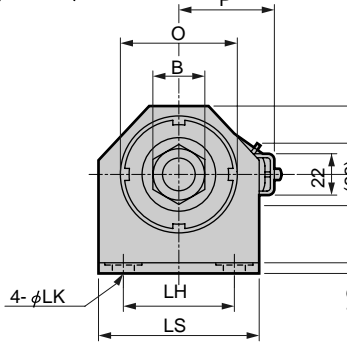

φ80, φ100

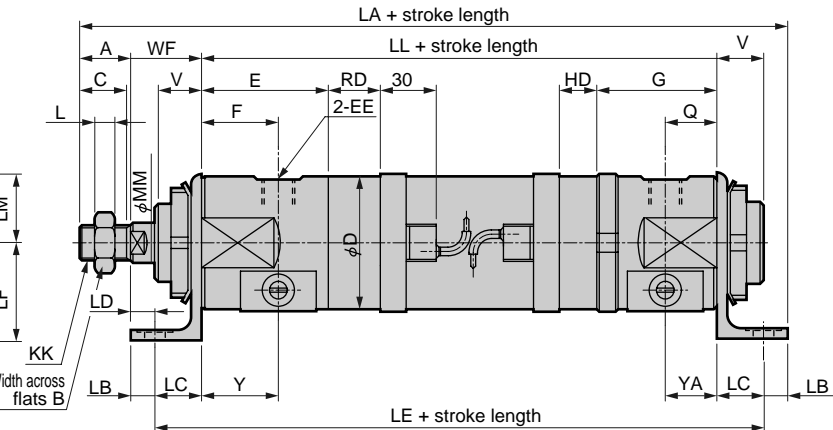
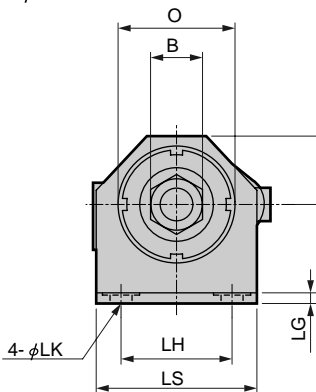

Note 1: Refer to page 1987 for dimensions of accessory.

Symbol	Axial foot type (LB) basic dimensions																	
	Bore size (mm)																	
φ20	20	13	18	25	86	Rc1/8	34	74	M8 x 1	5	223	10	4	8	42	22	16	24
φ25	20	17	18	30	82	Rc1/8	32.5	71	M10 x 1.25	6	213	12	5	10	42	21.5	16	32
φ32	22	17	20	37	67	Rc1/4	42	57	M10 x 1.25	6	197	12	5	10	42	25	20	30
φ40	22	22	20	46	73	Rc1/4	45.5	57	M14 x 1.5	8	203	16	6	14	57	25	20	32
φ50	28	27	26	56.4	77	Rc3/8	47.5	60	M18 x 1.5	11	211	20	7	17	62	24.5	20	33
φ63	28	27	26	69.4	69	Rc3/8	42	65	M18 x 1.5	11	214	20	7	17	62	29	25	38
φ80	36	32	34	88	73	Rc1/2	45	70	M22 x 1.5	13	232	25	10	22	86	31.5	25	42
φ100	45	41	43	108	72	Rc1/2	42	72	M26 x 1.5	16	235	30	11	27	86	30	30	48
Symbol	Installation dimensions												With switch					
	Bore size (mm)		Y	YA	LA	LB	LC	LD	LE	LF	LG	LH	LK	LM	LS	HD	P	RD
φ20		34	22	295	8	20	4	263	30	3.2	40	6.6	19	54	15.5	28	17.5	
φ25		32.5	21.5	293	8	20	12	253	30	3.2	40	6.6	19	54	13	34	14.5	
φ32		42	25	277	8	20	10	237	30	3.2	40	6.6	19	54	22	35	21	
φ40		45.5	25	289	10	22	10	247	40	3.2	40	9	24	58	22	39	21	
φ50		47.5	24.5	307	10	25	8	261	45	4.5	45	9	29	63	19	44	25	
φ63		42	29	318	13	25	13	264	53	5.5	60	11	36.5	86	21	52	28	
φ80		45	31.5	355	15	30	12	292	63	8	71	14	45	102	24.5	114	33.5	
φ100		42	30	373	15	30	18	295	75	8	85	14	54	118	25	134	35	

Dimensions



● Rod end flange type (FA)

φ 20, φ 25

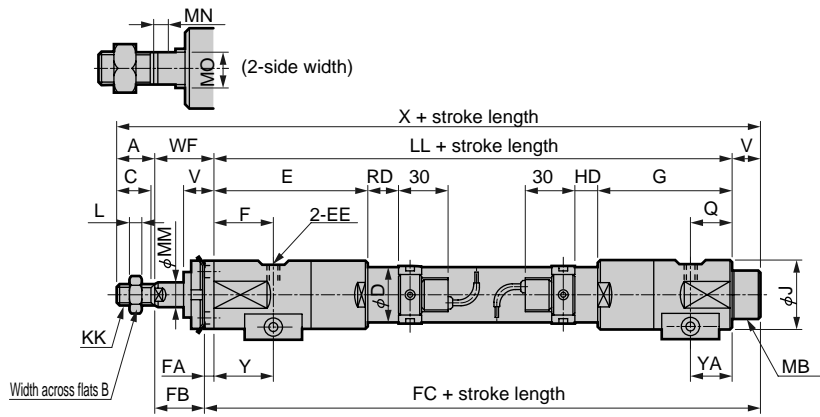
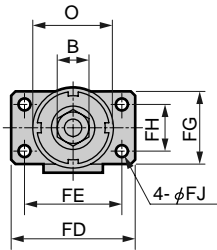

φ 32 to φ 63

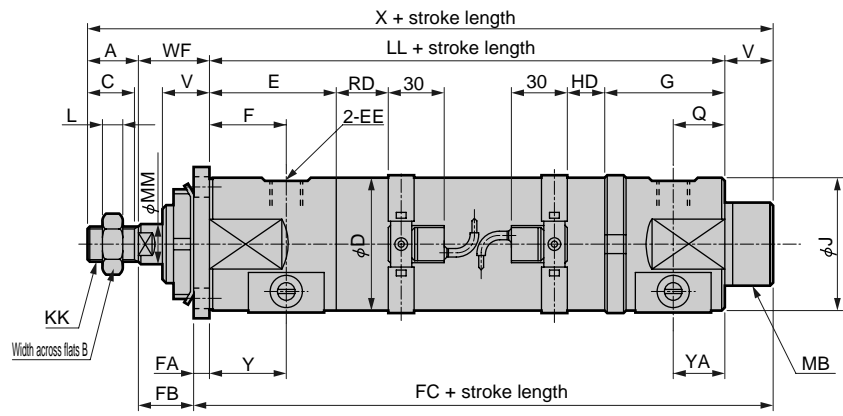
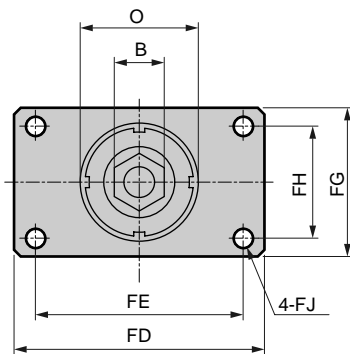

φ 80, φ 100

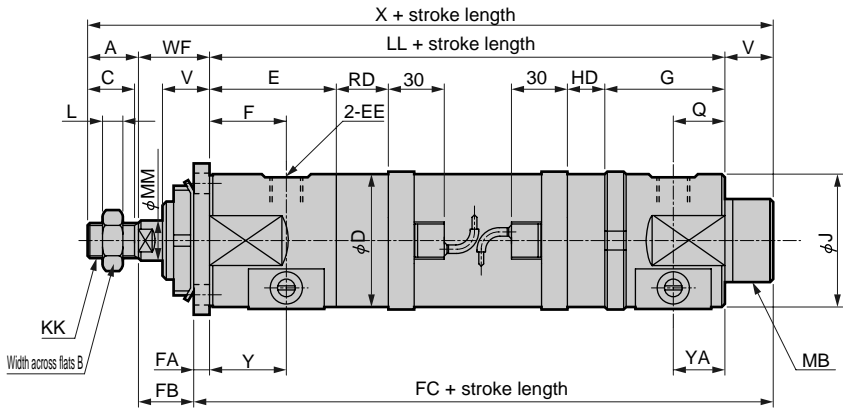
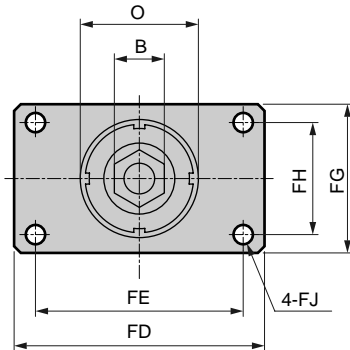

Note 1: Refer to page 1987 for dimensions of accessory.

Symbol	Rod end flange type (FA) basic dimensions																	
Bore size (mm)	A	B	C	D	E	EE	F	G	J	KK	L	LL	MB	MM	MN	MO	O	Q
φ 20	20	13	18	25	86	Rc1/8	34	74	33	M8 x 1	5	223	M25 x 1.5	10	4	8	42	22
φ 25	20	17	18	30	82	Rc1/8	32.5	71	37	M10 x 1.25	6	213	M25 x 1.5	12	5	10	42	21.5
φ 32	22	17	20	37	67	Rc1/4	42	57	37	M10 x 1.25	6	197	M25 x 1.5	12	5	10	42	25
φ 40	22	22	20	46	73	Rc1/4	45.5	57	46	M14 x 1.5	8	203	M35 x 1.5	16	6	14	57	25
φ 50	28	27	26	56.4	77	Rc3/8	47.5	60	56	M18 x 1.5	11	211	M40 x 1.5	20	7	17	62	24.9
φ 63	28	27	26	69.4	69	Rc3/8	42	65	69.4	M18 x 1.5	11	214	M40 x 1.5	20	7	17	62	29
φ 80	36	32	34	88	73	Rc1/2	45	70	88	M22 x 1.5	13	232	M60 x 2	25	10	22	86	31.5
φ 100	45	41	43	108	72	Rc1/2	42	72	108	M26 x 1.5	16	235	M60 x 2	30	11	27	86	30

Symbol	Installation dimensions												With switch		
Bore size (mm)	V	WF	X	Y	YA	FA	FB	FC	FD	FE	FG	FH	FJ	HD	RD
φ 20	16	24	283	34	22	4.5	19.5	243.5	66	52	38	24	6.6	15.5	17.5
φ 25	16	32	281	32.5	21.5	4.5	27.5	233.5	66	52	38	24	6.6	13	14.5
φ 32	20	30	269	42	25	4.5	25.5	221.5	66	52	38	24	6.6	22	21
φ 40	20	32	277	45.5	25	9	23	232	100	80	58	40	9	22	21
φ 50	20	33	292	47.5	24.5	9	24	240	108	90	65	45	9	19	25
φ 63	25	38	305	42	29	9	29	248	134	112	80	60	11	21	28
φ 80	25	42	335	45	31.5	14	28	271	160	132	100	71	14	24.5	33.5
φ 100	30	48	358	42	30	14	34	279	178	150	114	85	14	25	35

- SCP*2
- CMK2
- CMA2
- SCM
- SCG
- SCA2
- SCS
- CKV2
- CA/OV2
- SSD
- CAT
- MDC2
- MVC
- SMD2
- MSD*
- FC*
- STK
- ULK*
- JSK/M2
- JSG
- JSC3
- USSD
- USC
- JSB3
- LMB
- STG
- STS/L
- LCS
- LCG
- LCM
- LCT
- LCY
- STR2
- UCA2
- HCM**
- HCA**
- SRL2
- SRG
- SRM
- SRT
- MRL2
- MRG2
- SM-25
- CAC3
- UCAC
- RCC2
- MFC
- SHC
- GLC
- Ending

High speed cylinder
High-speed type

Dimensions



● Head end flange type (FB)

φ 20, φ 25

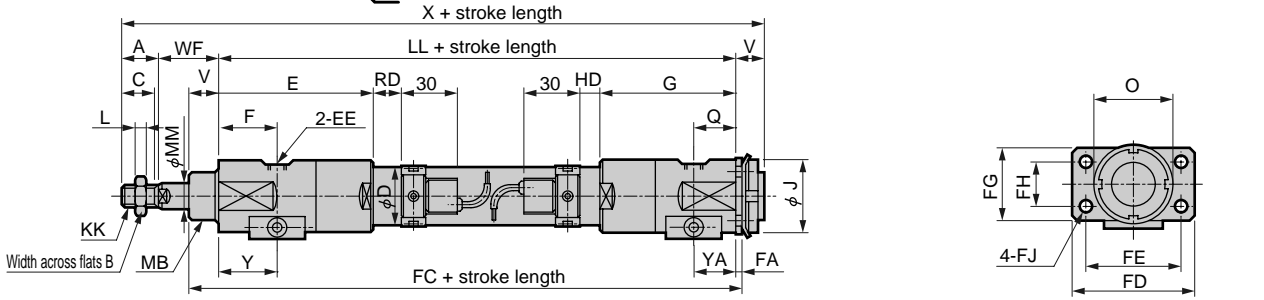
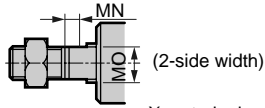

φ 32 to φ 63

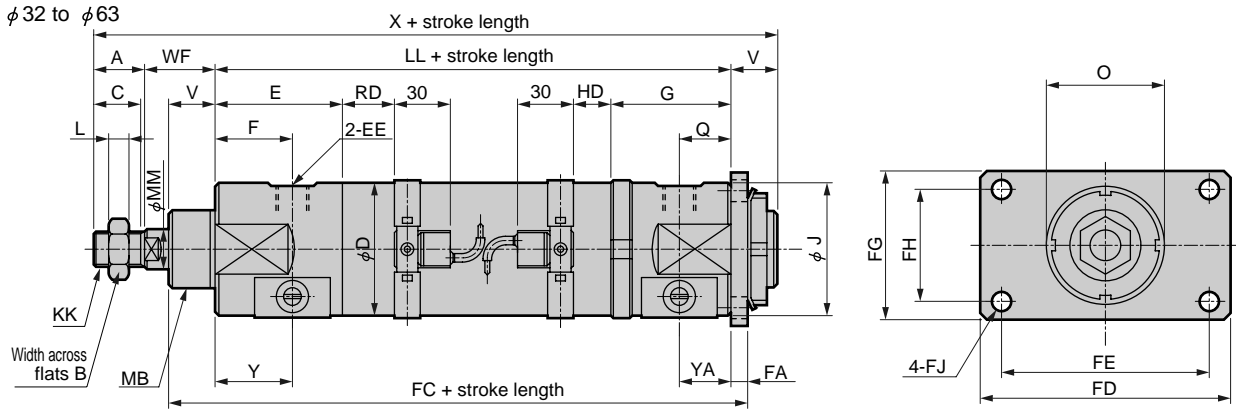

φ 80, φ 100

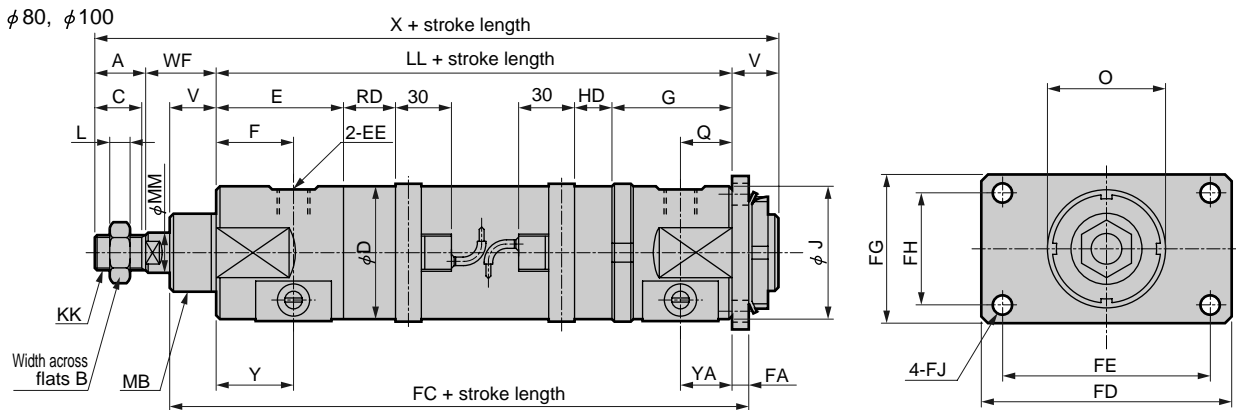

Note 1: Refer to page 1987 for dimensions of accessory.

Symbol	Head end flange type (FB) basic dimensions																	
Bore size (mm)	A	B	C	D	E	EE	F	G	J	KK	L	LL	MB	MM	MN	MO	O	Q
φ 20	20	13	18	25	86	Rc1/8	34	74	33	M8 x 1	5	223	M25 x 1.5	10	4	8	42	22
φ 25	20	17	18	30	82	Rc1/8	32.5	71	37	M10 x 1.25	6	213	M25 x 1.5	12	5	10	42	21.5
φ 32	22	17	20	37	67	Rc1/4	42	57	37	M10 x 1.25	6	197	M25 x 1.5	12	5	10	42	25
φ 40	22	22	20	46	73	Rc1/4	45.5	57	46	M14 x 1.5	8	203	M35 x 1.5	16	6	14	57	25
φ 50	28	27	26	56.4	77	Rc3/8	47.5	60	56	M18 x 1.5	11	211	M40 x 1.5	20	7	17	62	24.5
φ 63	28	27	26	69.4	69	Rc3/8	42	65	69.4	M18 x 1.5	11	214	M40 x 1.5	20	7	17	62	29
φ 80	36	32	34	88	73	Rc1/2	45	70	88	M22 x 1.5	13	232	M60 x 2	25	10	22	86	31.5
φ 100	45	41	43	108	72	Rc1/2	42	72	108	M26 x 1.5	16	235	M60 x 2	30	11	27	86	30
Symbol	Installation dimensions												With switch					
Bore size (mm)	V	WF	X	Y	YA	FA	FD	FE	FG	FH	FJ	FI	HD	RD				
φ 20	16	24	283	34	22	4.5	66	52	38	24	6.6	251.5	15.5	17.5				
φ 25	16	32	281	32.5	21.5	4.5	66	52	38	24	6.6	233.5	13	14.5				
φ 32	20	30	269	42	25	4.5	66	52	38	24	6.6	231.5	22	21				
φ 40	20	32	277	45.5	25	9	100	80	58	40	9	244	22	21				
φ 50	20	33	292	47.5	24.5	9	108	90	65	45	9	253	19	25				
φ 63	25	38	305	42	29	9	134	112	80	60	11	248	21	28				
φ 80	25	42	335	45	31.5	14	160	132	100	71	14	271	24.5	33.5				
φ 100	30	48	358	42	30	14	178	150	114	85	14	279	25	35				

Accessory dimensions

● Rod eye/clevis dimensions (φ20, 25, 32)

Rod eye (I)

Material: Steel

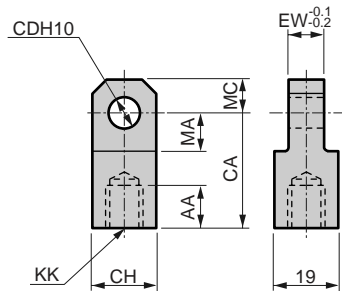

Model no.	Applicable bore size (mm)	AA	CA	CD	CH	EW	KK	MA	MC	Weight (g)
M1-I-20	20	14	30	10 ^{+0.058} ₀	19	8	M8 x 1	13	10	60
M1-I-30	25, 32	16	36	12 ^{+0.070} ₀	25	10	M10 x 1.25	16	12	110

Rod clevis (Y)

Material: Steel

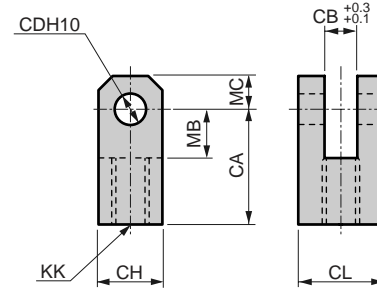

Note: A pin, a washer and a split pin are attached.

Model no.	Applicable bore size (mm)	CA	CB	CD	CH	CL	KK	MB	MC	Weight (g)
M1-Y-20	20	30	8	10 ^{+0.058} ₀	19	19	M8 x 1	13	10	100
M1-Y-30	25, 32	36	10	12 ^{+0.070} ₀	25	25	M10 x 1.25	16	12	210

● Rod eye/clevis dimensions (φ40, 50, 63, 80, 100)

Rod eye (I)

Material: Cast iron

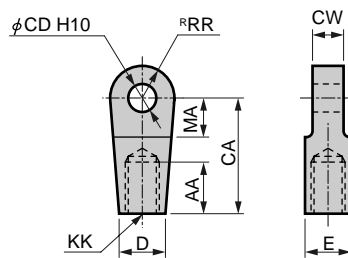

Model no.	Applicable bore size (mm)	AA	CA	CD	CW	D	E	KK	MA	RR	Weight (kg)
S1-I-40	40	20	50	12 ^{+0.070} ₀	18 ^{-0.1} _{-0.4}	27	27	M14 x 1.5	21	16	0.26
S1-I-50	50	21	50	12 ^{+0.070} ₀	18 ^{-0.1} _{-0.4}	27	27	M18 x 1.5	21	16	0.24
S1-I-63	63	21	50	14 ^{+0.070} ₀	20 ^{-0.1} _{-0.4}	27	27	M18 x 1.5	21	16	0.25
S1-I-80	80	30	70	20 ^{+0.084} ₀	28 ^{-0.1} _{-0.4}	46	41	M22 x 1.5	30	25	0.88
S1-I-100	100	30	70	20 ^{+0.084} ₀	22 ^{-0.1} _{-0.4}	46	41	M26 x 1.5	30	25	0.84

Rod clevis (Y)

Material: Cast iron

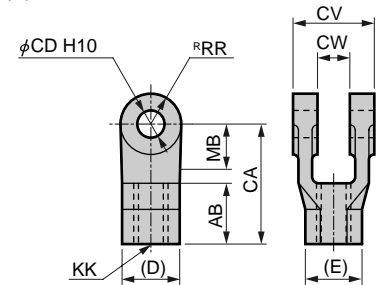

Note: A pin and a snap ring are attached.

Model no.	Applicable bore size (mm)	AB	CA	CD	CV	CW	D	E	KK	MB	RR	Weight (kg)
S1-Y-40	40	24	50	12 ^{+0.070} ₀	36	18 ^{+0.4} _{+0.1}	27	31.2	M14 x 1.5	19	16	0.25
S1-Y-50	50	24	50	12 ^{+0.070} ₀	36	18 ^{+0.4} _{+0.1}	27	31.2	M18 x 1.5	19	16	0.24
S1-Y-63	63	24	50	14 ^{+0.070} ₀	40	20 ^{+0.4} _{+0.1}	27	31.2	M18 x 1.5	19	16	0.26
S1-Y-80	80	35	70	20 ^{+0.084} ₀	56	28 ^{+0.4} _{+0.1}	41	47.3	M22 x 1.5	25	25	0.90
S1-Y-100	100	35	70	20 ^{+0.084} ₀	56	28 ^{+0.4} _{+0.1}	41	47.3	M26 x 1.5	25	25	0.85

Note: MB dimension indicates effective length of CW dimension.

● Pin dimensions

Pin (P) (φ20, 30)

Material: Steel

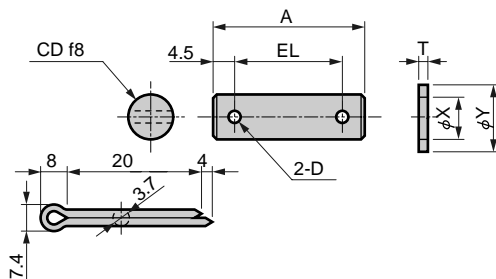

Model no.	Applicable bore size (mm)	A	D	CD	EL	T	X	Y	Weight (g)
M1-P-20	20	37	4	10 ^{-0.013} _{-0.035}	28	2	10.5	18	30
M1-P-30	25, 32	46	4	12 ^{-0.016} _{-0.043}	37	2.5	13	21	50

Note: For rod clevis type, a pin, a washer and a split pin are attached to the product.

Pin (P) (φ40, 50, 63, 80, 100)

Material: Steel

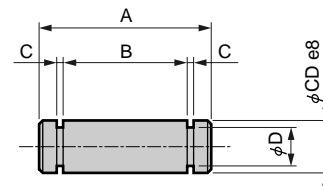

Model no.	Applicable bore size (mm)	A	B	C	D	CD	Weight (g)	Snap ring
S1-P-40	40, 50	43.5	36.2	1.15	11.5	12 ^{-0.032} _{-0.059}	40	Axis C type 12
S1-P-63	63	47.5	40.2	1.15	13.4	14 ^{-0.032} _{-0.059}	60	Axis C type 14
S1-P-80	80, 100	64	56.2	1.35	19	20 ^{-0.040} _{-0.073}	100	Axis C type 20

Note: For rod clevis type, a pin and a snap ring are attached to the product.

* Specify the model no., when placing an order.

SCP*2
CMK2
CMA2
SCM
SCG
SCA2
SCS
CKV2
CA/OV2
SSD
CAT
MDC2
MVC
SMD2
MSD*
FC*
STK
ULK*
JSK/M2
JSG
JSC3
USSD
USC
JSB3
LMB
STG
STS/L
LCS
LCG
LCM
LCT
LCY
STR2
UCA2
HCM
HCA
SRL2
SRG
SRM
SRT
MRL2
MRG2
SM-25
CAC3
UCAC
RCC2
MFC
SHC
GLC
Ending

High speed cylinder
High-speed type

Selection guide

When using a high speed cylinder, the cylinder speed and the kinetic energy should be considered.

Step 1

High speed cylinder selection guide

For pneumatic cylinders, average speed is different from maximum speed rush into cushion because of compressibility fluid.

When operating load W with average speed V1, find the required composite effective sectional area S and the maximum speed V according to the following table.

This table is just reference. Some values may vary depending on load direction and pipe length etc.

Average speed and max. speed at load factor of high speed cylinder (when air pressure = 0.5MPa)

Bore size (mm)	Average speed Load factor	V1 = 500mm/s			V1 = 1,000mm/s			V1 = 2,000mm/s		
		10%	20%	30%	10%	20%	30%	10%	20%	30%
φ 20 (A2 = 2.356)	W	1.57	3.14	4.71	1.57	3.14	4.71	1.57	3.14	4.71
	S	0.80	0.89	0.98	1.60	1.78	1.96	3.19	3.56	3.93
	V	630	689	714	1,260	1,378	1,482	2,512	2,756	2,971
φ 25 (A2 = 3.778)	W	2.45	4.91	7.36	2.45	4.91	7.36	2.45	4.91	7.36
	S	1.28	1.43	1.57	2.56	2.85	3.15	5.12	5.71	6.30
	V	628	690	740	1,257	1,376	1,485	2,514	2,757	2,970
φ 32 (A2 = 6.912)	W	4.02	8.04	12.1	4.02	8.04	12.1	4.02	8.04	12.1
	S	2.34	2.61	2.88	4.68	5.22	5.76	9.36	12.4	11.5
	V	630	692	747	1,261	1,383	1,494	2,521	2,758	2,983
φ 40 (A2 = 10.56)	W	6.28	12.6	18.8	6.28	12.6	18.8	6.28	12.6	18.8
	S	3.57	3.99	4.40	7.15	7.97	8.80	14.3	15.9	17.6
	V	630	693	747	1,261	1,383	1,494	2,521	2,765	2,988
φ 50 (A2 = 16.49)	W	9.82	19.6	29.5	9.82	19.6	29.5	9.82	19.6	29.5
	S	5.58	6.23	6.87	11.2	12.5	13.7	22.3	24.9	27.5
	V	630	693	747	1,265	1,389	1,490	2,518	2,768	2,990
φ 63 (A2 = 28.03)	W	15.6	31.2	46.8	15.6	31.2	46.8	15.6	31.2	46.8
	S	9.49	10.6	11.7	19.0	21.2	23.4	38.0	42.3	46.7
	V	632	694	749	1,266	1,389	1,498	2,531	2,771	2,989
φ 80 (A2 = 45.36)	W	25.1	50.3	75.4	25.1	50.3	75.4	25.1	50.3	75.4
	S	15.4	17.1	18.9	30.7	34.3	37.8	61.4	68.5	75.6
	V	634	692	744	1,264	1,388	1,495	2,527	2,773	2,990
φ 100 (A2 = 71.47)	W	39.3	78.5	118	39.3	78.5	118	39.3	78.5	118
	S	24.2	27.0	29.8	48.4	54.0	59.6	96.8	108	119
	V	632	694	748	1,264	1,387	1,496	2,529	2,774	2,987

W: Load weight (kg) S: Composite effective sectional area (mm²) V: Max. speed (mm/s) V1: Average speed (mm/s) A2: Piston rod side cross-section areas (cm²)

For example, when using HCA-40 with load 6.28kgf (load factor 10%, 0.5MPa) and average speed V1 = 2,000mm/s, the maximum speed is 2,521mm/s (1.26 time larger). In this case, required composite effective sectional area is 14.3mm².

Select system components matched to composite effective sectional area from the table on the following page.

System selection guide table

Appropriate system matched to the required cylinder speed according to bore size can be selected.

Bore size	Port size	Required effective sectional area (mm ²)	4.5 port valve for pneumatic control		Pneumatic auxiliary components		Piping
			Single solenoid	Double solenoid	Speed control valve	Silencer	Piping (m) (valve and cylinder interval)
φ 20	Rc1/8	1.3	4KA110-M5/4KB110-06 4GA110-M5/4GB110-06	4KA120-M5/4KB120-06 4GA120-M5/4GB120-06	SC3W-6/SC3R-6	SLW-6A	φ 4 x 2.5NT
		2.0	4KA110-M5/4KB110-06 4GA110-M5/4GB110-06	4KA120-M5/4KB120-06 4GA120-M5/4GB120-06	SC3R-6	SLW-6A	φ 6 x φ 4NT
		2.8	4KA210-06/4KB210-06 4GA210-06/4GB210-08	4KA220-06/4KB220-06 4GA220-06/4GB220-08	SC3R-6	SLW-6A	φ 8 x φ 5.7NT
		3.6	4KA210-06/4KB210-06 4GA210-06/4GB210-08	4KA220-06/4KB220-06 4GA220-06/4GB220-08	SC1-6	SLW-6A	φ 6 x φ 4NT
		4.3	4KA210-06/4KB210-06 4GA210-06/4GB210-08	4KA220-06/4KB220-06 4GA220-06/4GB220-08	SC1-6	SLW-6A	φ 8 x φ 5.7NT
φ 25	Rc1/8	1.4	4KA110-M5/4KB110-06 4GA110-M5/4GB110-06	4KA120-M5/4KB120-06 4GA120-M5/4GB120-06	SC3W-6	SLW-6A	φ 4 x φ 2.5NT
		2.4	4KA110-M5/4KB110-06 4GA110-M5/4GB110-06	4KA120-M5/4KB120-06 4GA120-M5/4GB120-06	SC3W-6	SLW-6A	φ 6 x φ 4NT
		4.4	4KA210-06/4KB210-06 4GA210-06/4GB210-08	4KA220-06/4KB220-06 4GA220-06/4GB220-08	SC1-6	SLW-6A	φ 6 x φ 4NT
		5.8	4KA210-06/4KB210-06 4GA210-06/4GB210-08	4KA220-06/4KB220-06 4GA220-06/4GB220-08	SC1-6	SLW-6A	φ 8 x φ 5.7NT
		6.6	4KA210-06/4KB210-06 4GA210-06/4GB210-08	4KA220-06/4KB220-06 4GA220-06/4GB220-08	SC1-8	SLW-6A	φ 10 x φ 7.2NT
φ 32	Rc1/4	3.6	4KB210-08/4GB210-08	4KB220-08/4GB220-08	SC3W-8/SC3R-8	SLW-8A	φ 6 x φ 4NT
		5.9	4KB210-08/4GB210-08	4KB220-08/4GB220-08	SC1-8	SLW-8A	φ 8 x φ 5.7NT
		8.4	4F210-08/4KB310-08 4GB310-08	4F220-08/4KB320-08 4GB320-08	SC1-8	SLW-8A	φ 10 x φ 7.2NT
		9.5	4KB310-08/4F310-08 4GB310-08	4KB320-08/4F320-08 4GB320-08	SC1-8	SLW-8A	φ 10 x φ 7.2NT
		11.6	4F310-08/4F410-08 4GB310-08	4F320-08/4F420-08 4GB320-08	SC3W-10/SC3R-10	SLW-8A	φ 12 x φ 8.9NT
φ 40	Rc1/4	3.6	4KB210-08/4GB310-08	4KB220-08/4GB320-08	SC3W-8/SC3R-8	SLW-8A	φ 6 x φ 4NT
		8.5	4F210-08/4KB310-08 4GB310-08	4F220-08/4KB320-08 4GB320-08	SC1-8	SLW-8A	φ 10 x φ 7.2NT
		12.0	4F310-08/4F410-08 4GB310-08	4F320-08/4F420-08 4GB320-08	SC3W-10/SC3R-10	SLW-8A	φ 12 x φ 8.9NT
		15.2	4F410-08	4F420-08	SC-1-10	SLW-8A	φ 12 x φ 8.9NT
		18.4	4F510-10	4F520-10	SC-1-10	SLW-10A	φ 15 x φ 11.5NT
φ 50	Rc3/8	5.5	4KB310-10/4F310-10	4KB320-10/4F320-10	SC3W-10/SC3R-10	SLW-10A	φ 6 x φ 4NT
		12.0	4K310-10/4F310-10	4K320-10/4F320-10	SC3W-10/SC3R-10	SLW-10A	φ 12 x φ 8.9NT
		18.1	4F510-10	4F520-10	SC1-10	SLW-10A	φ 12 x φ 8.9NT
		23.5	4F510-10	4F520-10	SC1-15	SLW-10A	φ 15 x φ 11.5NT
		26.9	4F610-15	4F620-15	SC1-15	SLW-15A	φ 15 x φ 11.5NT
φ 63	Rc3/8	11.0	4K310-10/4F310-10	4K320-10/4F320-10	SC3W-10/SC3R-10	SLW-10A	φ 10 x φ 7.2NT
		18.0	4K410-10/4F510-10	4K420-10/4F520-10	SC1-10	SL-10A	φ 10 x φ 7.2NT
		26.9	4F610-15	4F620-15	SC1-15	SLW-15A	φ 10 x φ 8.9NT
		43.1	4F610-15	4F620-15	SC-20A	SLW-15A	φ 15 x φ 11.5NT
φ 80	Rc1/2	62.8	4F610-20	4F620-20	SC-20A	SL-20A	Rc1/2 steel pipe
		19.5	4F610-15	4F620-15	SC3W-15/SC3R-15	SLW-15A	φ 12 x φ 8.9NT
		31.3	4F610-15	4F620-15	SC1-15	SLW-15A	φ 15 x φ 11.5NT
		67.4	4F610-20	4F620-20	SC-20A	SL-20A	Rc3/4 steel pipe
		85.9	4F710-20	4F720-20	SC-20A	SL-20A	Rc3/4 steel pipe
φ 100	Rc1/2	95.9	4F710-20	4F720-20	SC-25A	SL-20A	Rc3/4 steel pipe
		31.8	4F610-15	4F620-15	SC1-15	SLW-15A	φ 15 x φ 11.5NT
		67.4	4F610-20	4F620-20	SC-20A	SL-20A	Rc3/4 steel pipe
		85.9	4F710-20	4F720-20	SC-20A	SL-20A	Rc3/4 steel pipe
		95.9	4F710-20	4F720-20	SC-25A	SL-20A	Rc3/4 steel pipe
		109.9	4F710-25	4F720-25	SC-25A	SL-25A	Rc3/4 steel pipe

● Pneumatics basic circuit diagram

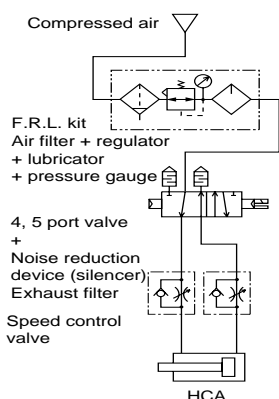

SCP*2
CMK2
CMA2
SCM
SCG
SCA2
SCS
CKV2
CA/OV2
SSD
CAT
MDC2
MVC
SMD2
MSD*
FC*
STK
ULK*
JSK/M2
JSG
JSC3
USSD
USC
JSB3
LMB
STG
STS/L
LCS
LCG
LCM
LCT
LCY
STR2
UCA2
HCM
HCA
SRL2
SRG
SRM
SRT
MRL2
MRG2
SM-25
CAC3
UCAC
RCC2
MFC
SHC
GLC

Ending

High speed cylinder
High-speed type

Step 2

High speed cylinder selection guide

Determine the model according to relations between load W and max. speed V on the following table.

High speed cylinder absorbing energy list

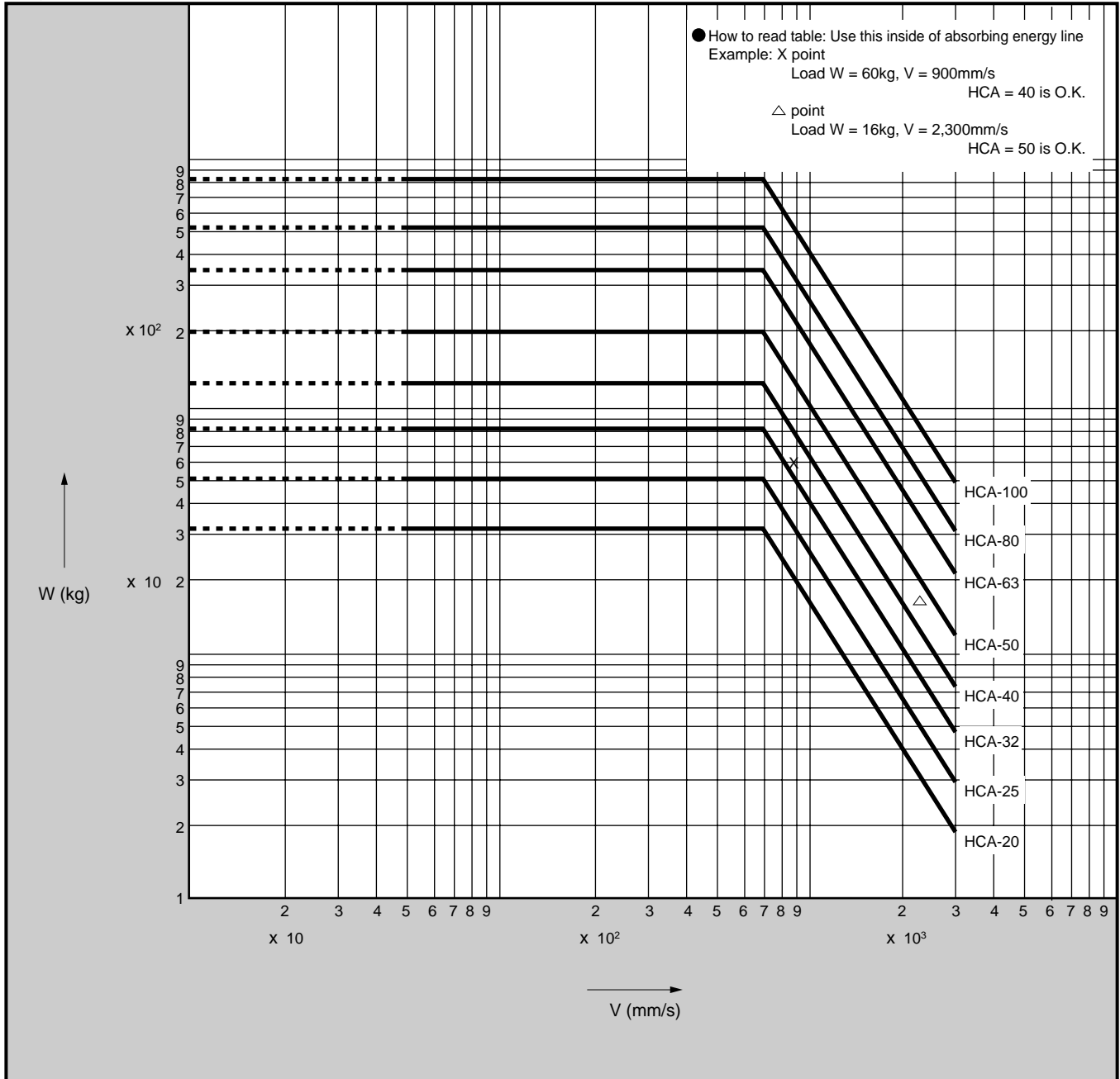

Note: This is log-log graph.

For example, when load W = 16kg, and maximum speed 2,300mm/s, △ shows that HCA-40 does not meet the conditions, but HCA-50 meets the conditions.