











● = Available in lineup
 - = Not available in lineup

*1: Main unit front operation section only *2: Custom order *3: Select with model

Model	Type	Pressure range (kPa)								Protective structure	Switch output (point) *3			Working fluid	Installation method							Indication		Page						
		Sensor, amplifier integrated type	Sensor, amplifier separate type	0 to 980 (1000)	0 to 98 (100)	0 to -100 (-101.3)	-100 to 980 (1000)	-100 to 300	-100 to 100		-101 to 500	NPN	PNP		Analog	FR installation	Panel mount	Others (bracket installation, etc)	Connecting port							Digital display	Only output light			
																			Rc1/8	R1/8	Push-in	Plug	M5 female thread		NPT1/8			G1/8		
 PPE	Trimmer setting type semiconductor pressure switch developed for pneumatic/vacuum circuits. Usage is flexible due to small and 3 types of connecting ports.	●	-	● (1000)	● (100)	● (-101.3)	-	-	-	-	-	-	● (2 wire) (1)	-	-	-	-	●	●	●	-	-	-	-	-	●	-	1094		
 PPE-A	Semiconductor pressure sensor developed for pneumatic/vacuum circuits. 1 to 5V output (analog output) is proportional to impressed pressure.	●	-	● (1000)	● (100)	●	-	-	-	-	-	-	-	-	● (1)	-	-	-	●	●	●	-	-	-	-	-	● (At energized)	1097		
 PSW	Reliable pressure switch developed for pneumatics/vacuum circuits. Semiconductor sensor is used, high precision / high speed response.	●	-	● (1000)	● (100)	●	-	-	-	-	-	-	● (1)	-	● (1)	-	-	●	-	-	-	-	-	-	-	●	-	1100		
 PPX	Digital pressure sensor with twin display of current and set pressure values confirmed simultaneously, a tricolor indicator, setting detail copy function, and three mode settings. This sensor provides to ease of use and high functionality.	●	-	-	-	● (1000)	-	●	-	-	-	IP40	● (2)	● (2)	-	Attached	●	●	-	●	●	●	-	-	-	-	-	-	-	1104
													● (1)	● (1)	● (1)															
 PPD3	Optimum digital indicator pressure switch for pneumatic lines. Due to various port options, adsorption confirmation / contact confirmation, etc. can be flexibly operated.	●	-	-	-	●	●	●	-	-	-	IP65	● (2)	● (2)	-	-	●	●	-	-	-	-	-	-	-	-	-	-	-	1126
													● (1)	● (1)	● (1)															
 PPD3-S	Pressure switch with digital display stainless steel diaphragm is used for sensor section.	●	-	-	-	●	●	●	-	-	-	IP65	● (2)	● (2)	-	Air/non-corrosive gas (Including drain and oil) Compressed air	-	●	●	-	-	-	-	-	-	-	-	-	-	1126
													● (1)	● (1)	● (1)															
 PPD	28mm square miniature switch with digital pressure display for pneumatic/vacuum circuits.	●	-	●	●	●	-	-	-	-	-	IP40	● (1)	● (1) *2	-	Air Non-corrosive gas	●	●	●	●	-	-	-	-	-	-	-	-	-	1142
													● (1)	● (1) *2																
 PPD-S	Stainless steel diaphragm is used for sensor section. For vacuum, withstanding pressure is 3-fold reinforced.	●	-	●	●	●	-	-	-	-	-	IP40	● (1)	● (1) *2	-	Air/non-corrosive gas (Including drain and oil) Compressed air	-	●	●	-	-	-	-	-	-	-	-	-	-	1146
													● (1)	● (1) *2																
 PPD-A	Equivalent to protective structure IP67, pressure switch with digital display in protective box allowing operation by a wet hand.	●	-	●	●	●	-	-	-	-	-	IP67	● (1)	● (1) *2	-	Air Non-corrosive gas	-	-	●	-	-	-	-	-	-	-	-	-	-	1148
													● (1)	● (1) *2																
 PPS2	Digital measurement display detecting air pressure/vacuum precisely. 4 point switch output allows wide applications.	●	-	● (1000)	● (100)	● (-101.3)	-	-	-	●	-	None (IP66 by option (*1))	● (Not polarized) (4)	● (1)	-	Air Non-corrosive gas	-	●	-	-	-	-	-	-	-	-	-	-	-	1152
		-	●	-	-	-	-	No body (IP66 by option (*1)) Sensor section: IP67																						

Electronic pressure switch
Pressure sensor

Electronic pressure switch

Applications of pressure switch

Refrigerating type dryer
Desiccant type dryer
High polymer membrane dryer
Air filter
Auto. drain / others
F.R.L. (Module unit)
F.R.L. (Separate)
Compact F.R.
Precise regulator
F.R.L. (Related products)
Clean F.R.
Electro pneumatic regulator
Air booster
Speed control valve
Silencer
Check valve / others
Joint / tube
Vacuum filter
Vacuum regulator
Suction plate
Magnetic spring buffer
Mechanical pressure SW
Electronic pressure SW
Contact / close contact conf. SW
Air sensor
Pressure SW for coolant
Small flow sensor
Small flow controller
Flow sensor for air
Flow sensor for water
Total air system
Total air system (Gamma)
Ending

● Positive pressure / vacuum confirmation and interlock

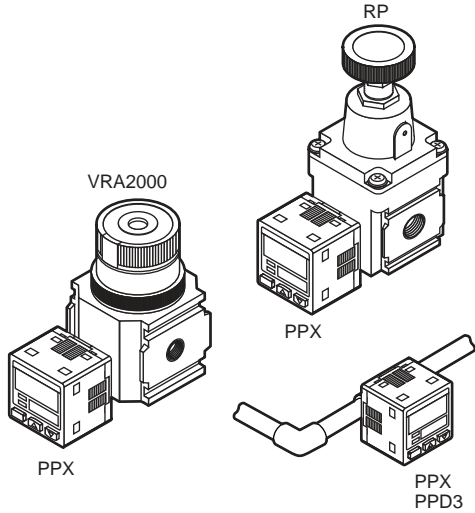

● High-function type

· Settings are made easy with automatic reference and remote zero adjustment.

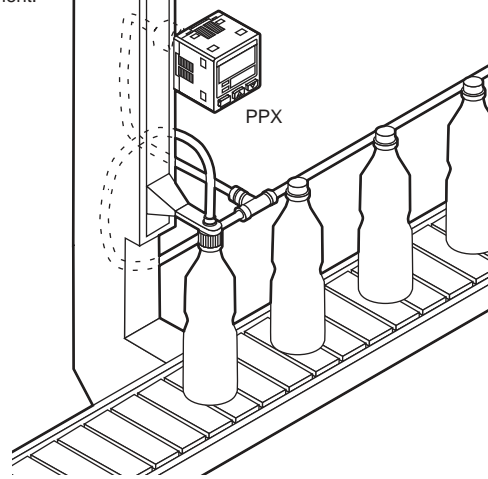

● Manifold

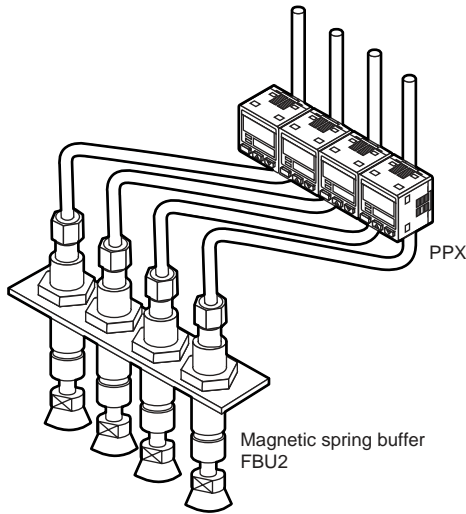

● Attain vacuum and break pressure with one unit

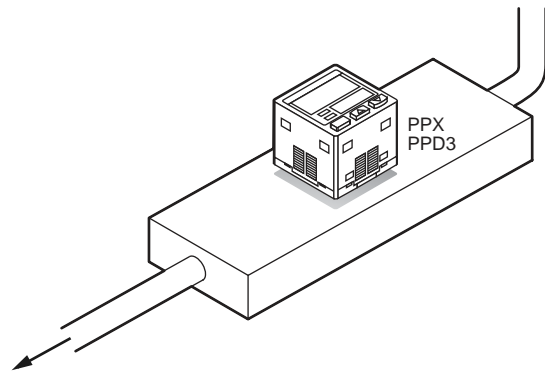

Electronic pressure switch

Applications

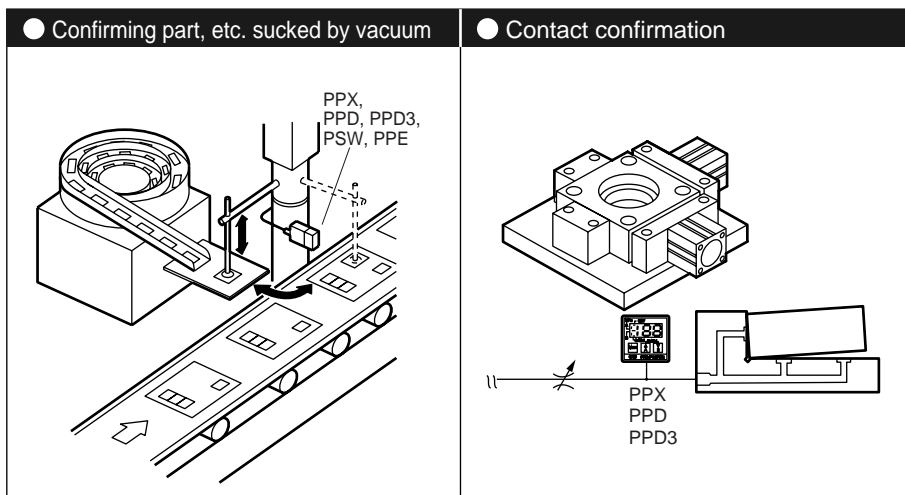
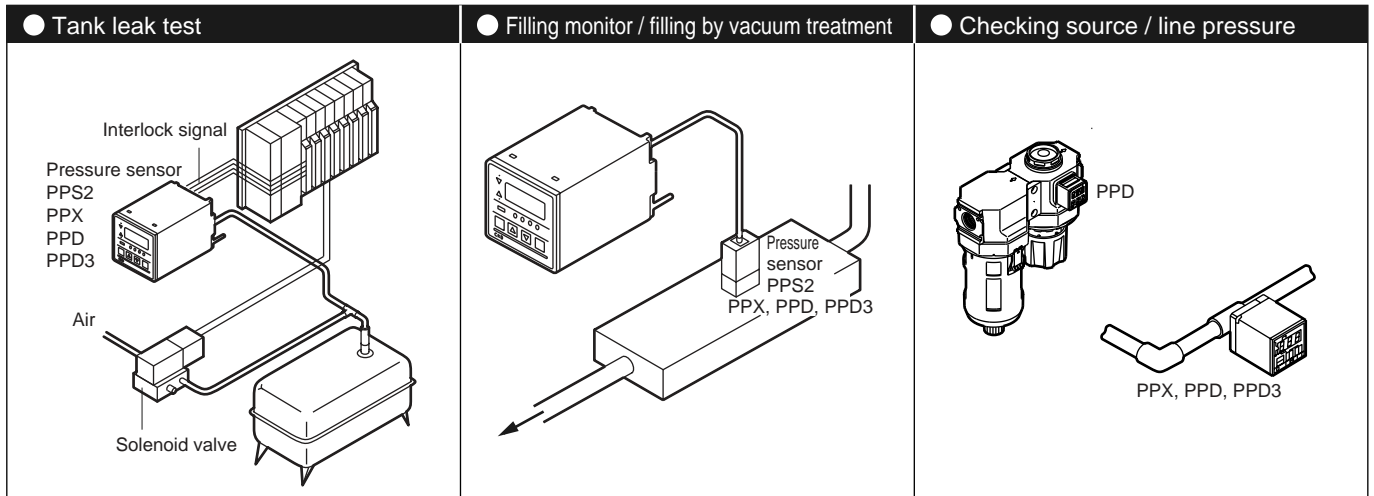

Refrigerating type dryer
Desiccant type dryer
High polymer membrane dryer
Air filter
Auto. drain / others
F.R.L. (Module unit)
F.R.L. (Separate)
Compact F.R.
Precise regulator
F.R.L. (Related products)
Clean F.R.
Electro pneumatic regulator
Air booster
Speed control valve
Silencer
Check valve / others
Joint / tube
Vacuum filter
Vacuum regulator
Suction plate
Magnetic spring buffer
Mechanical pressure SW
Electronic pressure SW
Contact / close contact cont. SW
Air sensor
Pressure SW for coolant
Small flow sensor
Small flow controller
Flow sensor for air
Flow sensor for water
Total air system
Total air system (Gamma)

Ending

Electronic pressure switch
Pressure sensor



Pneumatic components (electronic pressure switch and sensor)

Safety precautions

Always read this section before starting use.

Refer to Intro 67 for general precautions, and to "⚠ Safety Precautions" in this section for details on each series.

Refrigerating type dryer
Desiccant type dryer
High polymer membrane dryer
Air filter
Auto. drain / others
F.R.L. (Module unit)
F.R.L. (Separate)
Compact F.R.
Precise regulator
F.R.L. (Related products)
Clean F.R.
Electro pneumatic regulator
Air booster
Speed control valve
Silencer
Check valve / others
Joint / tube
Vacuum filter
Vacuum regulator
Suction plate
Magnetic spring buffer
Mechanical pressure SW
Electronic pressure SW
Contact / close contact conf. SW
Air sensor
Pressure SW for coolant
Small flow sensor
Small flow controller
Flow sensor for air
Flow sensor for water
Total air system
Total air system (Gamma)
Ending

Design & Selection

⚠ WARNING

■ Use this product in accordance of specifications.

- Use for applications, or at load currents, voltages, temperatures, impacts or sites excluded from the specifications could result in damage or malfunctions.

■ Do not use oxygen, corrosive or combustible gas, or toxic fluid for this product.

■ Do not use this product in flammable atmosphere.

- The pressure switch does not have an explosive-proof structure. Never use in an explosive gas environment as explosions or fires could result.

■ Avoid installing this product in a sealed control box or indoors.

- If the fluid should leak due to any trouble, the pressure in the sealed chamber could change and recreate a hazardous state. Use this product in the control box having safety device to control internal pressure, or indoors with no pressure differential from the outside.

■ Power voltage

Use the product within the specified power voltage range. The product could rupture or burn if voltage exceeding the working range is applied or if an AC power supply (100 VAC) is applied.

■ Load short circuit

Do not short-circuit the load. Failure to observe this could result in rupture or burning.

■ Incorrect wiring

Avoid incorrect wiring such as wrong polarity of power source, etc. Failure to observe this could result in rupture or burning.

⚠ CAUTION

■ Working fluid

When using working fluid other than air; nitrogen gas, etc., oxygen deficiency could be caused. Observe the following instructions.

- Use this product in well ventilated locations.
- Ventilate the work area when nitrogen gas is being used.
- Inspect piping regularly, so nitrogen gas piping does not leak.
- Non-corrosive gas means substances such as nitrogen or carbon dioxide contained in air and inert gases such as argon or neon.
- When using this product for compressed air containing water or oil, use the PPD(3)-S (stainless steel diaphragm sensor specifications) with increased corrosion resistance.

■ If this product is used for vacuum suction confirmation, care must be taken for following matters.

- When applying positive pressure for vacuum break onto the product, check that it does not exceed the specified withstand pressure.

■ Working Environment

- Avoid using this product where vibration or impact exceeding 100m/s² could be applied.
- Check the temperature of fluid being measured and the environmental temperature in piping.
- When using a type that does not have the corresponding protective structure, do not use for applications in which water or oil could be applied.

■ Determine the setting taking error caused by accuracy and temperature characteristics into consideration.

■ Take care when using this product for an interlock circuit.

- When using the pressure switch for an interlock signal required high reliability, provide a double interlock by installing a mechanical protection function or a switch (sensor) other than a pressure switch as a guard if problems occur. Execute inspection regularly to check that the normal operation is done.

(Recommended value)

Model	Protective structure
PPX/PPD/PPD-S	IP40
PPE (-A)/PPD3 (-S)	IP65
PPS2 front controls (option)	IP66
PPD-A/PPS2 sensor's separate sensor section only	IP67

■ Response is affected by working pressure and load volume. If repeatability with stable responsiveness is required, install a regulator in the proceeding stage.

■ Take the following countermeasures to prevent malfunction caused by noise.

- Provide a line filter in AC power line.
- Do not share power with an inverter or components causing motor noise, etc.
- Use a surge suppressor, such as a CR or diode on the inductive load (solenoid valve, relay, etc.), and remove noise where generated.
- When using a device such as a switching regulator or inverter motor that could generate noise near the sensor, be sure to ground the device frame ground (F.G.) terminal.
- Separate wiring to the sensors from strong magnetic fields.
- Connect wiring to sensors with a shield wire.
- Ground the shield wire on the power supply side.

■ When the secondary side control pressure is released to atmosphere as air blow, pressure may fluctuate depended on piping and blow conditions. Execute a test under actual working conditions or contact to CKD.

■ Select the product whose flow is not less than the total of that used for sensors when selecting a dryer, an air filter, an oil mist filter and a regulator.

Installation & Adjustment

⚠ WARNING

- Avoid incorrect connection.
 - An incorrect connection may cause a fatal error not only to this product but also peripheral devices.
- DC power not insulated from AC primary side may damage the product and power, so an electric shock could occur. Do not use the product in this case.

⚠ CAUTION

- Do not use the product where the product is exposed to direct-sunlight or may come in contact with water or oil.
- Flash air pipe connected to sensors before connecting. Prevent pipe from catching tips of sealing tape when piping.
- Correct pressure control is not possible if the exhaust port is plugged. Release this port into the atmosphere.
- Apply adequate torque when connecting pipes.
 - To prevent air leakage and screw damage.
 - First tighten the screw by hand to prevent damage to screw threads, then use a tool.

Port thread	Tightening torque N·m
M3	0.3 to 0.6
M5	1 to 1.5
Rc1/8	3 to 5
Rc1/8 (resin)	1 to 1.5



- Care must be taken for protection of body and lead wire.
 - Do not bump or drop the main unit, or apply excessive bending or tensile strength to the lead because the lead could be disconnected.
 - Connect and wire bending-resistant material, such as robot wire material, for the movable sections.
- Wiring
 - Turn power OFF before wiring this product. Discharge static electricity charged in human body, tool or equipment before and during operation.
 - Use a stabilized noise-free power supply with a ripple voltage of 1% or less.

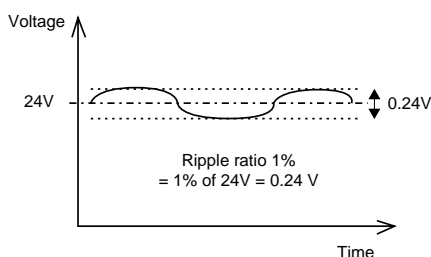

- Turn the power on and off at the quick rising and falling edges of voltage. If the rated voltage is not reached, the sensor could malfunction. In some cases, the sensor could not recover after the rated voltage is reached. Reset the power in that case. Even if the voltage drops temporarily, shut down the power once, then turn ON the power again.
 - Install the product and wiring as far as possible from noise source such as a strong electric line. Take separate measures against surge generated from inductive loads that enter the power supply.
 - Do not operate the control unit, machinery or equipment immediately after wiring. Due to wrong setting, signals not expected could be outputted. First stop control unit, machinery and equipment, while energize these to test. Set the target setting after test.
- Stop machinery and equipment, and check safety before setting switch output.
 - Operate keys manually. Sharp instruments, such as knives or screwdriver, contacting plastic film on the operation section could damage film and compromise its protective functions.

■ Piping

- Use the recommended tube for the push-in joint, and connect to the assembled push-in joint after flushing.
 - * Recommended tube: 6mm O.D. CKD F-1506, U-9506, etc.
- Apply seal tape or sealant on the threaded joint, and screw in while taking care not to tighten excessively. Apply a spanner on the metal section to tighten. (Only PPE and PPD-R * D-6 have a resin section)
- When winding sealing tape, wind from 2mm and over inward from the end of threads on the pipe.
 - * If sealing tape protrudes from the end of pipe threads, it could be cut when the joint is screwed in and cut pieces could get inside and cause problems.



- Limit the pipe length to 1m, and check that excessive tensile strength or impact is not applied. If the tube is too long, unpredicted tensile strength could be generated from tube weight, and by vibration and impact. Fix or relay the tube to the machine or equipment midway so that tube weight is not applied.
- Avoid connecting the output for a relay contact, operation switch, or other component output in parallel with the PC to the product's output, or short-circuit the input terminal of the PC to which this product is connected with the power supply cable's minus side to test the input device, or the output circuit of this unit could be damaged.

- Refrigerating type dryer
- Desiccant type dryer
- High polymer membrane dryer
- Air filter
- Auto. drain / others
- F.R.L. (Module unit)
- F.R.L. (Separate)
- Compact F.R.
- Precise regulator
- F.R.L. (Related products)
- Clean F.R.
- Electro pneumatic regulator
- Air booster
- Speed control valve
- Silencer
- Check valve / others
- Joint / tube
- Vacuum filter
- Vacuum regulator
- Suction plate
- Magnetic spring buffer
- Mechanical pressure SW
- Electronic pressure SW
- Contact / close contact cont. SW
- Air sensor
- Pressure SW for coolant
- Small flow sensor
- Small flow controller
- Flow sensor for air
- Flow sensor for water
- Total air system
- Total air system (Gamma)
- Ending

Electronic pressure switch
Pressure sensor

Refrigerating type dryer
Desiccant type dryer
High polymer membrane dryer
Air filter
Auto. drain / others
F.R.L (Module unit)
F.R.L (Separate)
Compact F.R.
Precise regulator
F.R.L (Related products)
Clean F.R.
Electro pneumatic regulator
Air booster
Speed control valve
Silencer
Check valve / others
Joint / tube
Vacuum filter
Vacuum regulator
Suction plate
Magnetic spring buffer
Mechanical pressure SW
Electronic pressure SW
Contact / close contact conf. SW
Air sensor
Pressure SW for coolant
Small flow sensor
Small flow controller
Flow sensor for air
Flow sensor for water
Total air system
Total air system (Gamma)
Ending

Installation & Adjustment

CAUTION

- Some models have a push in joint for the measured pressure port. Check the perpendicularity of the tube side, and check that there are no scratches, indents, or dirt near the end. Air and compressed air are measured. Check that water and dirt do not enter the tube during piping.

During Use & Maintenance

WARNING

- Do not apply overcurrent.
 - If overcurrent flows to the pressure switch because of a load short circuit, etc., the pressure switch will be damaged and could also ignite. Provide an overcurrent protection circuit, such as a fuse, for the output wire and power cable.

CAUTION

- Do not disassemble the products.
 - The product could be damaged or performance compromised if this product is disassembled. CKD does not guarantee performance after disassembly. Remove the entire installation section (pressurized port section) when replacing or moving this product.
 - With the PPD-*IF-* type, the case must be removed during initial assembly. Take special care in handling. (Be sure to follow assembly methods and precautions given in the instruction manual enclosed with the product.)

- Stop machinery and equipment, then check the safety before operating the product.

- With PPD/PPD3/PPS2, pressure is detected 200 times per second, but this display is updated 4 times a second, and cannot track fast pressure changes. The switch could therefore start operating at quickly changing pressure even when the display does not indicate the switch setting.

- The case is made of resin. Do not use solvent, alcohol, or detergent in cleaning, or resin could absorb it. Wipe contaminations with a well wrung rag, etc., after soaked in weakened neutral detergent.

- Care must be taken for disconnection and reverse current caused by wiring resistance.

When other devices, including pressure switches, are connected to the same power supply as the pressure switch, and the output cable and power cable's minus side are short-circuited or the power supply's minus side is disconnected to check operation of the input device from the control panel, reverse current could flow to the pressure switch's output circuit and cause damage.

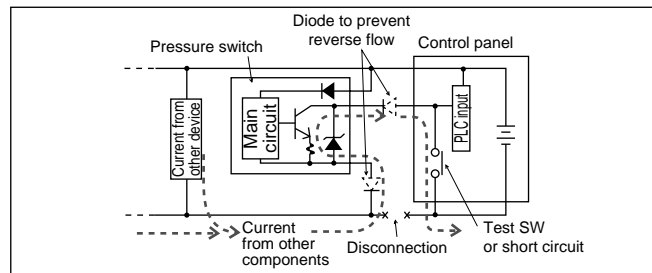

Take countermeasures as followings to prevent damages caused by reverse current.

- Avoid centralizing current at the power cable, especially the minus side power cable, and use as thick as possible.
- Limit the number of devices connected to the same power supply as the pressure switch.
- Insert a diode in serial with the pressure switch's output cable to prevent reversal of current.
- Insert a diode in serial with the pressure switch's power cable minus side to prevent reversal of current.

- Care must be taken for surge current leading.

When the power is shared with inductive loads that create surge current such as pressure switches, solenoid valves or relays, if the circuit is closed with inductive loads activated, surge current could lead to the output circuit, causing damages.

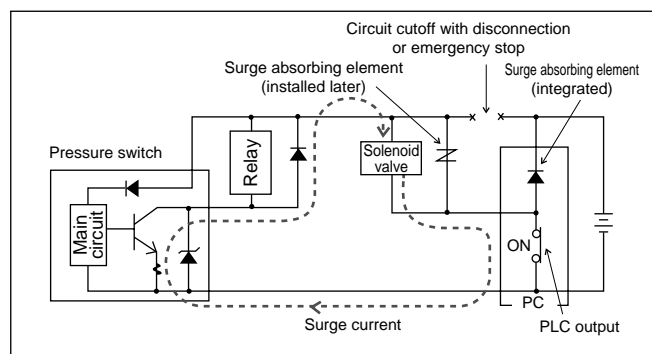

Take countermeasures as followings to prevent damage caused by surge current leading.

- (1) Separate the power supply for the output system comprising the inductive load, such as the solenoid valve and relay, and the input system, such as the pressure switch.
- (2) If separate power supplies cannot be used, directly install a surge absorption element for all inductive loads. Remember that the surge absorption element connected to the PLC, etc., protects only that device.
- (3) Connect a surge absorption element to the following places on the power wiring as shown below as a measure against disconnections in unspecific areas:

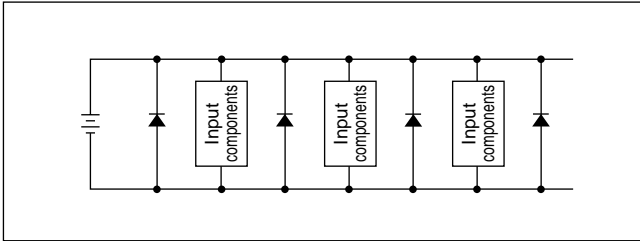

When components are connected with connectors, if a connector is dislocated during energizing, the output device could be damaged because of the reason above. Turn off the power before dislocating a connector.

Refrigerating type dryer
Desiccant type dryer
High polymer membrane dryer
Air filter
Auto. drain / others
F.R.L. (Module unit)
F.R.L. (Separate)
Compact F.R.
Precise regulator
F.R.L. (Related products)
Clean F.R.
Electro pneumatic regulator
Air booster
Speed control valve
Silencer
Check valve / others
Joint / tube
Vacuum filter
Vacuum regulator
Suction plate
Magnetic spring buffer
Mechanical pressure SW
Electronic pressure SW
Contact / close contact cont. SW
Air sensor
Pressure SW for coolant
Small flow sensor
Small flow controller
Flow sensor for air
Flow sensor for water
Total air system
Total air system (Gamma)

Ending

Electronic pressure switch
Pressure sensor

Refrigerating type dryer
Desiccant type dryer
High polymer membrane dryer
Air filter
Auto. drain / others
F.R.L (Module unit)
F.R.L (Separate)
Compact F.R.
Precise regulator
F.R.L. (Related products)
Clean F.R.
Electro pneumatic regulator
Air booster
Speed control valve
Silencer
Check valve / others
Joint / tube
Vacuum filter
Vacuum regulator
Suction plate
Magnetic spring buffer
Mechanical pressure SW
Electronic pressure SW
Contact / close contact conf. SW
Air sensor
Pressure SW for coolant
Small flow sensor
Small flow controller
Flow sensor for air
Flow sensor for water
Total air system
Total air system (Gamma)
Ending

Electronic pressure switch PPE Series

Design & Selection

⚠ WARNING

- The main body and joint connection rotate, but this section should not repeatedly rotate during use.
- The protective structure is equivalent to IP65, but this product must not be used in an environment where it could come in contact with water. Check that cutting oil and coolant do not come in contact.
- Care must be taken for internal voltage drop.
 - When using with a voltage less than specified voltage, the pressure switch may be activated correctly, but the load may not function correctly. Check the load's working voltage, and check that the following expression is satisfied:
 $\text{Power voltage} - \text{internal voltage drop} > \text{load working voltage}$

■ Care must be taken for leakage current.

- Even when the 2-wire pressure switch is OFF, current (leakage current) flows to operate the internal circuit. (1mA or less)

Load working current > leakage current

If the above expression is not satisfied, the switch may be interpreted as ON even when it is OFF, and operation fail. Use the 3-wire PPD if specifications are not met. If n units are connected in parallel, the current that flows to the load increases n-fold.

- The customer is responsible for checking safety and taking appropriate means for using fluids other than applicable fluids. Do not use this product for corrosive or flammable gases or for oxygen.

Installation & Adjustment

⚠ CAUTION

■ Handling the product

- When installing the product, hold the body while taking care not to bang the unit or apply excessive stress to loads.
- Do not disassemble or overhaul the product. If disassembled, parts could pop off when pressure is applied. CKD does not guarantee performance after disassembly.

■ Load short circuit protection circuit

- If the load is inadvertently short-circuited, the internal load short-circuit protection circuit is activated and the switch remains OFF. Fix wiring, then turn power OFF, or short-circuit the PPE's brown and blue wires to recover normal switch operations.

<Cautions on installation>

■ Driver

Use a flat-tip screwdriver that fits into the trimmer slot (0.5W x 2.3L x 0.5D) when setting.

■ Trimmer

The rotation range of the trimmer is 240 degree. The trimmer could be damaged if turned any further or if turned forcibly.

■ Opening and closing the trimmer cover

Use a flat-tip screwdriver to open the trimmer cover and set the trimmer. After setting, press the trimmer cover with a finger and completely close it. The protective structure (IP65) is not satisfied if the cover is not completely closed.

Setting pressure and switch operations

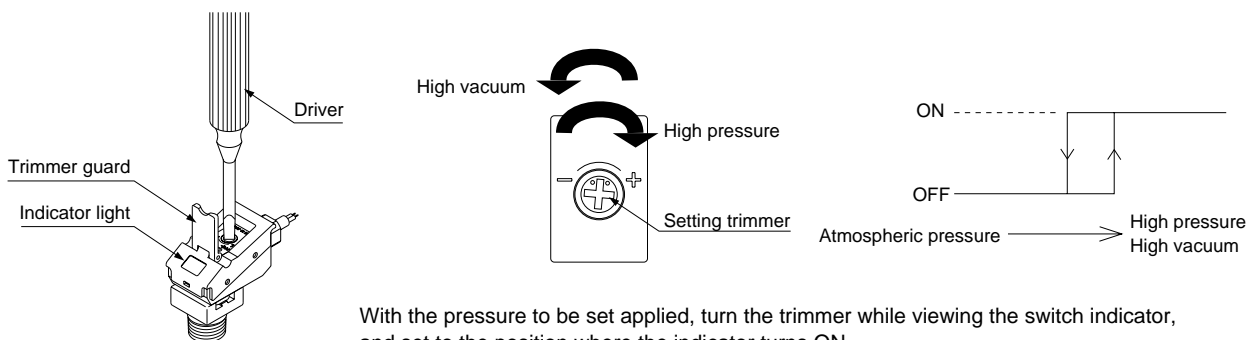

With the pressure to be set applied, turn the trimmer while viewing the switch indicator, and set to the position where the indicator turns ON.

Piping method

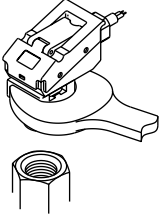
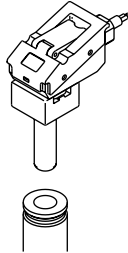
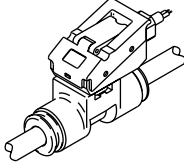
PPE-*-6	PPE-*-H6-B	PPE-*-H6
		
<p>Use sealing tape or sealant, and catch a wrench against the cross width section (13mm) of the R1/8 joint into install.</p> <p>(Cautions)</p> <ul style="list-style-type: none"> The tightening torque is 1.0 to 1.5N·m or less. Resin parts may be damaged if tightened too far. 	<p>Insert the CKD 6mm tube push-in joint and use.</p> <p>(Cautions)</p> <ul style="list-style-type: none"> Securely insert the plug section, and check that the plug is not dislocated. If the plug is not fully inserted, it could be dislocated or air could leak. Use the applicable push-in joint. <ul style="list-style-type: none"> GW Series GWJ Series 	<p>Insert the 6mm tube into the two push-in joints and use.</p> <p>(Cautions)</p> <ul style="list-style-type: none"> Use the designated tube and plastic plug. <ul style="list-style-type: none"> Tube outer diameter precision <ul style="list-style-type: none"> Nylon, soft nylon tube : Within $\pm 0.1\text{mm}$ Polyurethane rubber tube: Within $+ 0.1\text{mm}$ Urethane tube : Within $- 0.2\text{mm}$ Use a tube with a hardness of 93° and over. Securely insert the tube, and check that the tube is not dislocated. If the tube is not fully inserted, it could be dislocated or air could leak. Cut the tube with a dedicated cutter, and cut at a right angle.

Refrigerating type dryer
Desiccant type dryer
High polymer membrane dryer
Air filter
Auto. drain / others
F.R.L. (Module unit)
F.R.L. (Separate)
Compact F.R.
Precise regulator
F.R.L. (Related products)
Clean F.R.
Electro pneumatic regulator
Air booster
Speed control valve
Silencer
Check valve / others
Joint / tube
Vacuum filter
Vacuum regulator
Suction plate
Magnetic spring buffer
Mechanical pressure SW
Electronic pressure SW
Contact / close contact cont. SW
Air sensor
Pressure SW for coolant
Small flow sensor
Small flow controller
Flow sensor for air
Flow sensor for water
Total air system
Total air system (Gamma)

Ending

Electronic pressure switch
Pressure sensor

Refrigerating type dryer
Desiccant type dryer
High polymer membrane dryer
Air filter
Auto. drain / others
F.R.L. (Module unit)
F.R.L. (Separate)
Compact F.R.
Precise regulator
F.R.L. (Related products)
Clean F.R.
Electro pneumatic regulator
Air booster
Speed control valve
Silencer
Check valve / others
Joint / tube
Vacuum filter
Vacuum regulator
Suction plate
Magnetic spring buffer
Mechanical pressure SW
Electronic pressure SW
Contact / close contact conf. SW
Air sensor
Pressure SW for coolant
Small flow sensor
Small flow controller
Flow sensor for air
Flow sensor for water
Total air system
Total air system (Gamma)
Ending

Electronic pressure sensor analog output type PPE-*A Series

Design & Selection

⚠ WARNING

■ Wiring

Connect cable with power turned OFF. Discharge static electricity from personnel or tools before and during work. Connect and wire bending-resistant material, such as robot wire material, for the movable sections.

■ Installation

Install this product and wiring as far as possible from noise source such as a strong electric line. Take separate measures against surge that enter the power wire.

■ Power voltage

Use the product within the specified power voltage range. The product could rupture or burn if voltage exceeding the working range is applied or if an AC power supply (100 VAC) is applied.

■ Load short circuit

Do not short-circuit the load. Failure to observe this could result in rupture or burning.

■ Incorrect wiring

Avoid incorrect wiring such as wrong polarity of power source, etc. Failure to observe this could result in rupture or burning.

■ Connecting load

When connecting an inductive load such as relay or solenoid valve, a surge voltage is generated when the switch is turned OFF. Directly connect a flywheel diode onto all inductive loads in the same power circuit.

■ Connecting load

The output impedance of the analog output section is 1KΩ. If the impedance of the connected load is small, output error increases. Check error with the impedance of the connected load before using.

Example of calculation

(PPE-*A output impedance: $R_o = 1K\Omega$
Load internal impedance: $R_x = 1M\Omega$

$$\begin{aligned} \text{Output value} &= \left(1 - \frac{R_o}{R_o + R_x}\right) \times 100\% \\ &= \left(1 - \frac{1K\Omega}{1K\Omega + 1M\Omega}\right) \times 100\% \Rightarrow \text{approx. } 0.1\% \end{aligned}$$

Installation & Adjustment

⚠ CAUTION

■ When installing the product, hold the body while taking care not to bang the unit or apply excessive stress to loads.

■ The customer is responsible for checking safety and taking appropriate means for using fluids other than applicable fluids. Do not use this product for corrosive or flammable gases or for oxygen.

■ When applying positive pressure for vacuum break onto the product to check vacuum suction, check that it does not exceed the specified withstand pressure.

■ Do not disassemble or dismantle the product. If disassembled, parts could pop off when pressure is applied. The performance after disassembly is not guaranty.

■ The main body and joint connection rotate, but this section should not repeatedly rotate during use.

■ The protective structure is equivalent to IP65, but this product must not be used in an environment where it could come in contact with water. Check that cutting oil and coolant do not come in contact.

(Piping)

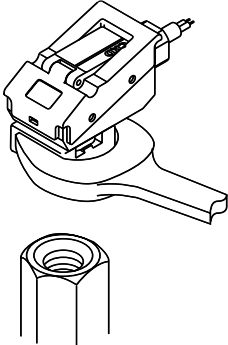
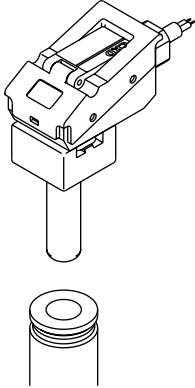
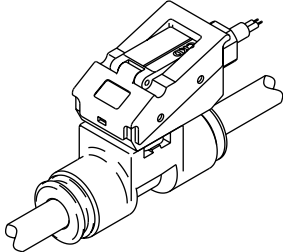
PPE-*A-6	PPE-*A-H6-B	PPE-*A-H6
		
<p>Use sealing tape or sealant, and catch a wrench against the cross width section (13mm) of the R1/8 joint into install.</p> <p>(Cautions)</p> <ul style="list-style-type: none"> The tightening torque is 1.0 to 1.5N·m or less. Resin parts may be damaged if tightened too far. 	<p>Insert the CKD 6mm tube push-in joint and use.</p> <p>(Cautions)</p> <ul style="list-style-type: none"> Securely insert the plug section, and check that the plug is not dislocated. If the plug is not fully inserted, it could be dislocated or air could leak. Use the applicable push-in joint. <ul style="list-style-type: none"> GW Series GWJ Series 	<p>Insert the 6mm tube into the two push-in joints and use.</p> <p>(Cautions)</p> <ul style="list-style-type: none"> Use the designated tube and plastic plug. <ul style="list-style-type: none"> Tube outer diameter precision <ul style="list-style-type: none"> Nylon, soft nylon tube : Within ± 0.1mm Polyurethane rubber tube : Within $+ 0.1$mm Urethane tube : Within $- 0.2$mm Use a tube with a hardness of 93° and over. Securely insert the tube, and check that the tube is not dislocated. If the tube is not fully inserted, it could be dislocated or air could leak. Cut the tube with a dedicated cutter, and cut at a right angle.

Refrigerating type dryer
Desiccant type dryer
High polymer membrane dryer
Air filter
Auto. drain / others
F.R.L. (Module unit)
F.R.L. (Separate)
Compact F.R.
Precise regulator
F.R.L. (Related products)
Clean F.R.
Electro pneumatic regulator
Air booster
Speed control valve
Silencer
Check valve / others
Joint / tube
Vacuum filter
Vacuum regulator
Suction plate
Magnetic spring buffer
Mechanical pressure SW
Electronic pressure SW
Contact / close contact cont. SW
Air sensor
Pressure SW for coolant
Small flow sensor
Small flow controller
Flow sensor for air
Flow sensor for water
Total air system
Total air system (Gamma)

Ending

Electronic pressure switch
Pressure sensor

Compact electronic pressure switch

PPE Series



Refer to Intro 32 for details.



Overview

Pressure switch PPE Series is trimmer setting type semiconductor pressure switch developed for pneumatic/vacuum systems. Usage is flexible due to small shape and three types of connecting port (R1/8, ϕ 6 plug, ϕ 6 push-in joint)

Features

- Semiconductor pressure sensor
Used semiconductor sensor pressure detection, high precision and high reliability are achieved.
- 2 wire
Due to 2 wire type, wiring man-hour is reduced, and both PLC input formats (source and sink) can be used.
- High withstanding pressure
Withstanding pressure of negative pressure type (V01) is as high as 0.6MPa, so the product can withstand to vacuum break by pressurization.
- Reverse connection / over current protection circuit integrated
A protective circuit for improper wire connection (reverse connection, load short circuit) is integrated.
- Wide port size
R1/8
 ϕ 6 plug
 ϕ 6 push-in joint

Specifications

Model no.	Vacuum		Positive pressure	
	PPE-V01- <input type="checkbox"/> <small>Note 1</small>	PPE-P01- <input type="checkbox"/> <small>Note 1</small>	PPE-P10- <input type="checkbox"/> <small>Note 1</small>	
Descriptions				
Pressure range	-101.3 to 0kPa	0 to 100kPa	0 to 1MPa	
Name plate color <small>Note 2</small>	Red	Green	Blue	
Pressure sensitive element	Carrier diffusion type semiconductor pressure sensor			
Working fluid	Air/non-corrosive gas			
Withstanding pressure	0.6MPa	0.3MPa	1.5MPa	
Repeatability	\pm 1%F.S.			
Hysteresis	3%F.S. or less			
Temperature characteristics	\pm 3%F.S.			
Load voltage	10 to 30 VDC			
Load current	5 to 50mA			
Internal voltage drop	4V or less			
Leakage current	1mA or less			
Light display	Yellow LED lights when power turns ON			
Lead wire length	Standard 3m (oil resistant vinyl cabtire cable 2-conductor 0.15mm ² isolator outer diameter ϕ 1.0)			
Ambient temperature range	0 to 50°C (no freezing)			
Mechanical vibration proof	10 to 55Hz compound amplitude 1.5mm 4 hours per X, Y, Z direction			
Protective structure	IEC standards IP65 or equivalent			
Piping method	R1/8, ϕ 6 plug, ϕ 6 push-in joint			

Note 1: section is matched to piping section. (Refer to How to order)

Note 2: Name plate color is changed per pressure range. (To prevent improper use)

Clean room specifications (catalog No. CB-033SA)

- Dust generation preventing structure for use in cleanrooms

PPE-..... -

PPE-..... -

Refrigerating type dryer
Desiccant type dryer
High polymer membrane dryer
Air filter
Auto. drain / others
F.R.L (Module unit)
F.R.L (Separate)
Compact F.R.
Precise regulator
F.R.L (Related products)
Clean F.R.
Electro pneumatic regulator
Air booster
Speed control valve
Silencer
Check valve / others
Joint / tube
Vacuum filter
Vacuum regulator
Suction plate
Magnetic spring buffer
Mechanical pressure SW
Electronic pressure SW
Contact / close contact conf. SW
Air sensor
Pressure SW for coolant
Small flow sensor
Small flow controller
Flow sensor for air
Flow sensor for water
Total air system
Total air system (Gamma)
Ending

How to order

PPE - **V01** - **6**

A Pressure range

B Piping shape

Symbol	Descriptions
A Pressure range	
V01	-101.3 to 0kPa
P01	0 to 101kPa
P10	0 to 1MPa
B Piping shape	
6	R1/8
H6-B	φ6mm plug
H6	Inline type for φ6 push-in joint (2 pcs.)

Internal structure and parts list

● PPE-*-6

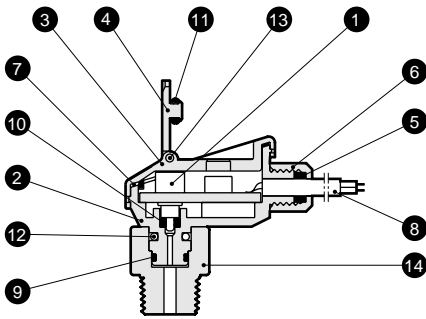

● PPE-*-H6-B

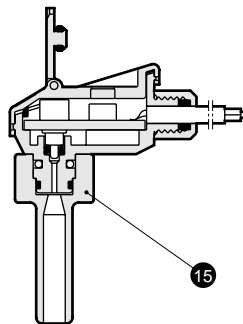

● PPE-*-H6

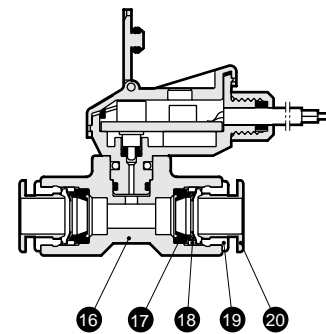

No.	Parts name	Material	No.	Parts name	Material
1	Pressure sensor	Carrier diffusion type semiconductor strain gauge	11	O ring	Nitrile rubber
2	Body	PBT (glass fiber 30%)	12	Stopper	Stainless steel
3	Guard	Polycarbonate	13	Spring pin	Stainless steel
4	Trimmer guard	Polycarbonate	14	R1/8	PBT (glass fiber 30%)
5	Bush	Nitrile rubber	15	Plug	PBT (glass fiber 30%)
6	Bush holder	Aluminum	16	Push-in joint	PBT
7	Guard gasket	Silicon rubber	17	Packing seal	Nitrile rubber
8	Lead wire (3m)	Polyvinyl chloride	18	Chuck	Brass (electroless nickeling)
9	O ring	Nitrile rubber	19	Outer ring	Brass (electroless nickeling)
10	O ring	Nitrile rubber	20	Push ring	Polyacetal

Dimensions



● PPE-*-6

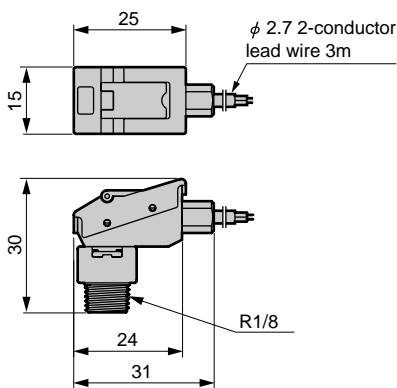

● PPE-*-H6-B

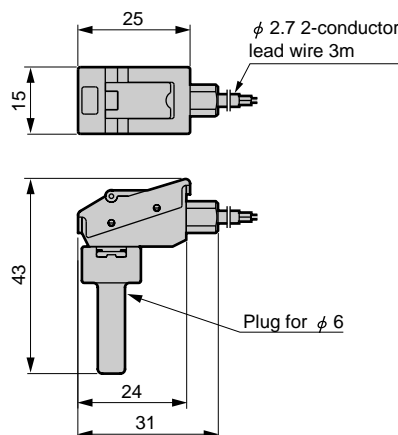

● PPE-*-H6

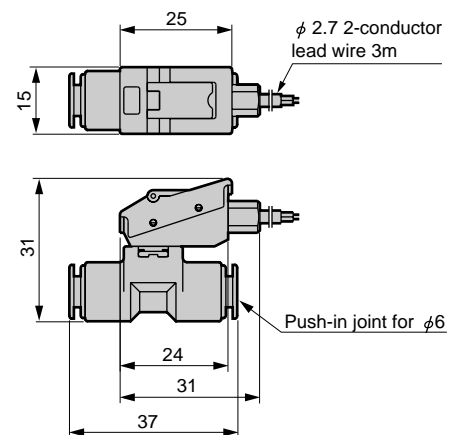

Refer to Precaution PPE Series on pages 1082 to 1083 for each component.

Refrigerating type dryer
Desiccant type dryer
High polymer membrane dryer
Air filter
Auto. drain / others
F.R.L. (Module unit)
F.R.L. (Separate)
Compact F.R.
Precise regulator
F.R.L. (Related products)
Clean F.R.
Electro pneumatic regulator
Air booster
Speed control valve
Silencer
Check valve / others
Joint / tube
Vacuum filter
Vacuum regulator
Suction plate
Magnetic spring buffer
Mechanical pressure SW
Electronic pressure SW
Contact / close contact cont. SW
Air sensor
Pressure SW for coolant
Small flow sensor
Small flow controller
Flow sensor for air
Flow sensor for water
Total air system
Total air system (Gamma)
Ending

Electronic pressure switch
Pressure sensor

Internal circuit / connection method

● Internal circuit diagram

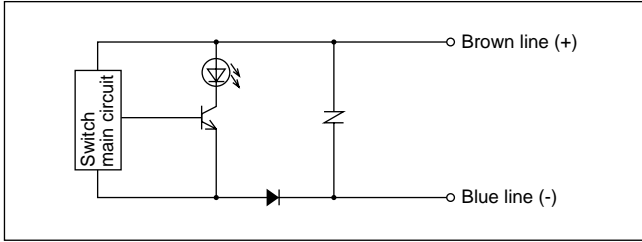

● Connection of lead wire

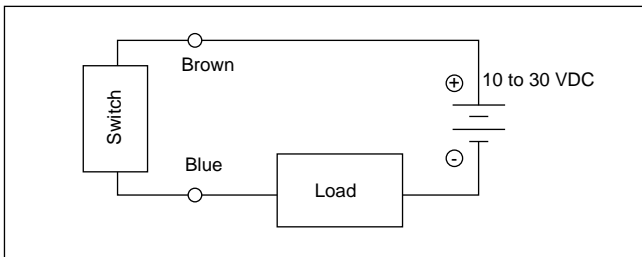
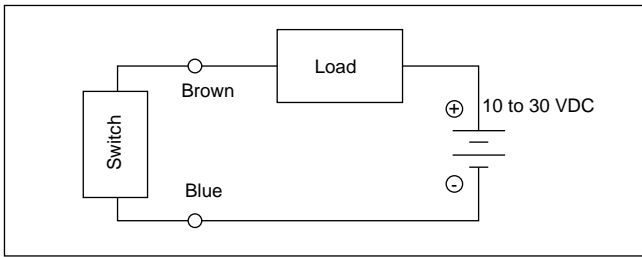

● Connection to programmable controller (PLC)

● Connection to source load input (external electric power) type

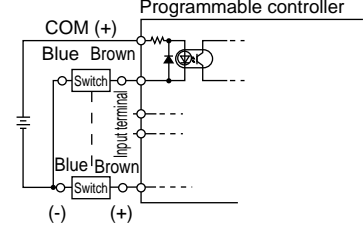

● Connection to source load input (internal electric power) type

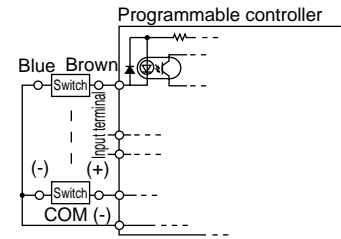

● Connection to sink input type

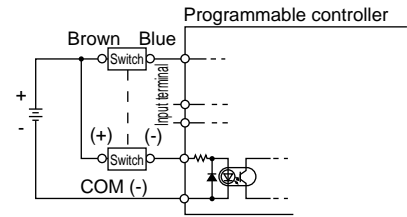

Refrigerating type dryer
Desiccant type dryer
High polymer membrane dryer
Air filter
Auto. drain / others
F.R.L (Module unit)
F.R.L (Separate)
Compact F.R.
Precise regulator
F.R.L (Related products)
Clean F.R.
Electro pneumatic regulator
Air booster
Speed control valve
Silencer
Check valve / others
Joint / tube
Vacuum filter
Vacuum regulator
Suction plate
Magnetic spring buffer
Mechanical pressure SW
Electronic pressure SW
Contact / close contact conf. SW
Air sensor
Pressure SW for coolant
Small flow sensor
Small flow controller
Flow sensor for air
Flow sensor for water
Total air system
Total air system (Gamma)
Ending

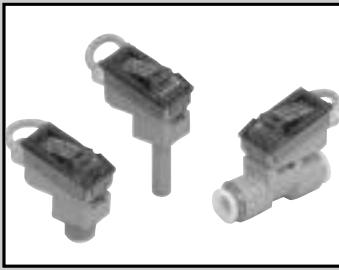

Compact electronic pressure sensor
Analog output type

PPE-*A Series

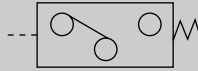

Refer to Intro 32 for details.



Overview

Pressure sensor PPE-A Series is semiconductor pressure sensor developed for pneumatic and vacuum systems. Output proportional to impressed voltage: 1 to 5V (analog output).

Usage is flexible due to small shape and three types of connecting port (R1/8, ϕ 6 plug, ϕ 6 push-in joint)

Specifications

Model no.	Vacuum		Positive pressure	
	PPE-V01A-□ Note 1	PPE-P01A-□ Note 1	PPE-P10A-□ Note 1	
Descriptions				
Pressure range	0 to -100kPa	0 to 100kPa	0 to 1MPa	
Name plate line color Note 2	Red	Green	Blue	
Pressure sensitive element	Carrier diffusion type semiconductor pressure sensor			
Working fluid	Air/non-corrosive gas			
Withstanding pressure	0.3MPa	0.3MPa	1.5MPa	
Precision	$\pm 1\%$ F.S. or less			
Linearity	$\pm 0.3\%$ F.S. or less			
Analog output	1 to 5V (output impedance 1K Ω)			
Power voltage	12 to 24 VDC $\pm 10\%$ (ripple ratio 1% or less)			
Current consumption	10mA or less			
Light display	Green LED lights, when power supply turns ON			
Lead wire length	Standard 3m (oil resistant vinyl cable, 3-conductor, 0.15mm ² isolator outer diameter ϕ 1.0)			
Protective circuit	Power supply reverse connection protection load phase fault protection			
Ambient temperature	0 to 50°C (no freezing)			
Temperature characteristics	$\pm 0.12\%$ F.S./°C or less			
Insulation resistance	20M Ω and over with 500 VDC			
Withstanding voltage	1000 VAC for one minute			
Mechanical vibration proof	10 to 55Hz compound amplitude 1.5mm, 4 hours per X, Y, Z direction			
Protective structure	IEC standards IP65 or equivalent			
Piping method	R1/8, ϕ 6 plug, ϕ 6 push-in joint			

Note 1: □ section is matched to piping section. (Refer to How to order.)

Note 2: Name plate color is changed per pressure range. (To prevent improper use)

Clean room specifications (catalog No. CB-033SA)

- Dust generation preventing structure for use in cleanrooms

PPE-*A- - (P70)

PPE-*A- - (P80)

How to order

PPE - **V01** **A** - **6**

A Pressure range

B Piping shape

Symbol	Descriptions
A Pressure range	
V01	0 to -100kPa
P01	0 to 100kPa
P10	0 to 1MPa
B Piping shape	
6	R1/8
H6-B	ϕ 6mm plug
H6	Inline type for ϕ 6 push-in joint (2 pcs.)



Refrigerating type dryer
Desiccant type dryer
High polymer membrane dryer
Air filter
Auto. drain / others
F.R.L. (Module unit)
F.R.L. (Separate)
Compact F.R.
Precise regulator
F.R.L. (Related products)
Clean F.R.
Electro pneumatic regulator
Air booster
Speed control valve
Silencer
Check valve / others
Joint / tube
Vacuum filter
Vacuum regulator
Suction plate
Magnetic spring buffer
Mechanical pressure SW
Electronic pressure SW
Contact / close contact cont. SW
Air sensor
Pressure SW for coolant
Small flow sensor
Small flow controller
Flow sensor for air
Flow sensor for water
Total air system
Total air system (Gamma)

Ending

Internal structure and parts list

● PPE-*A-6

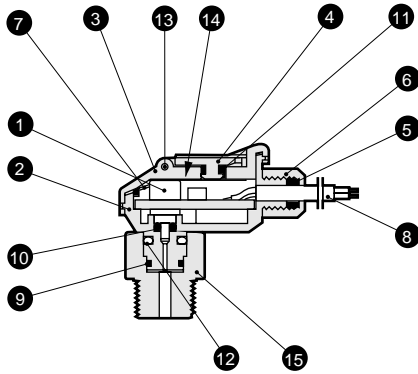

● PPE-*A-H6-B

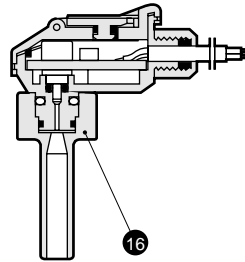

● PPE-*A-H6

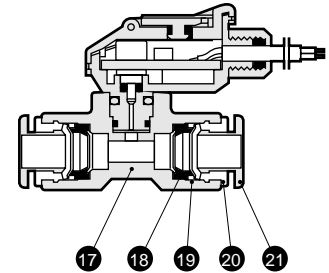

No.	Parts name	Material	No.	Parts name	Material
1	Pressure sensor	Carrier diffusion type semiconductor strain gauge	12	Stopper	Stainless steel
2	Body	PBT (glass fiber 30%)	13	Spring pin	Stainless steel
3	Guard	Polycarbonate	14	Shield seat	Aluminum
4	Trimmer guard	Polycarbonate	15	R1/8	PBT (glass fiber 30%)
5	Bush	Nitrile rubber	16	Plug	PBT (glass fiber 30%)
6	Bush holder	Aluminum	17	Push-in joint	PBT
7	Guard gasket	Silicon rubber	18	Packing seal	Nitrile rubber
8	Lead wire (3m)	Polyvinyl chloride	19	Chuck	Brass (electroless nickeling)
9	O ring	Nitrile rubber	20	Outer ring	Brass (electroless nickeling)
10	O ring	Nitrile rubber	21	Push ring	Polyacetal
11	O ring	Nitrile rubber			

Dimensions



● PPE-*A-6

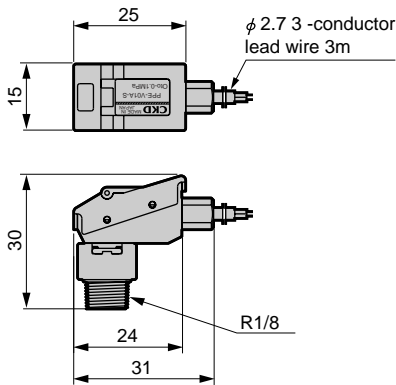

● PPE-*A-H6-B

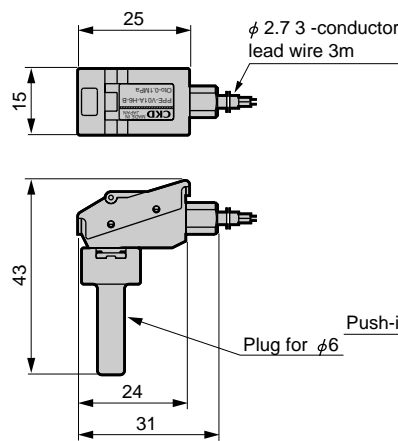

● PPE-*A-H6

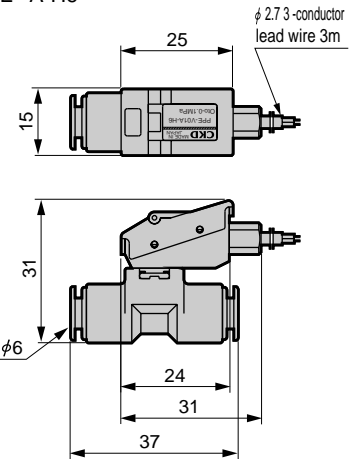

⚠ Cautions

- Analog output accuracy is also affected by self exoergic at energized other than temperature characteristics. Provide enough stand-by time (5minutes and over after energizing) before starting operation.
- Refer to precautions in PPE-*A Series on pages 1084 to 1085.

Analog output voltage - pressure characteristics

● PPE-V01A-*

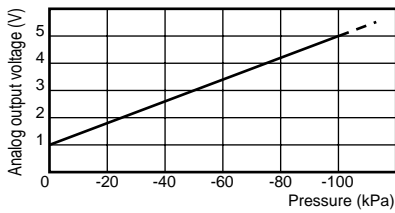

● PPE-P01A-*

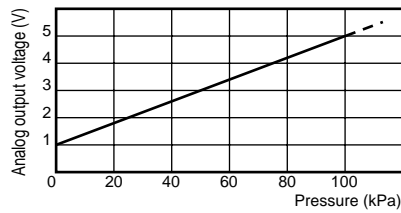

● PPE-P10A-*

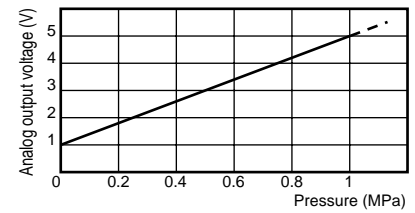

Internal circuit / connection method

<Circuit diagram and connection method>

● Internal circuit diagram

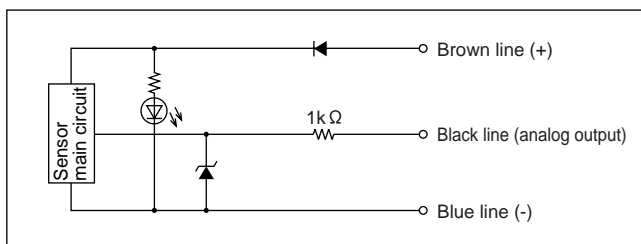

● Lead wire color and descriptions

Line color	Descriptions
Brown	Power supply 12 to 24 VDC
Black	Analog output (1 to 5V)
Blue	0V (GND)

● Connection of lead wire

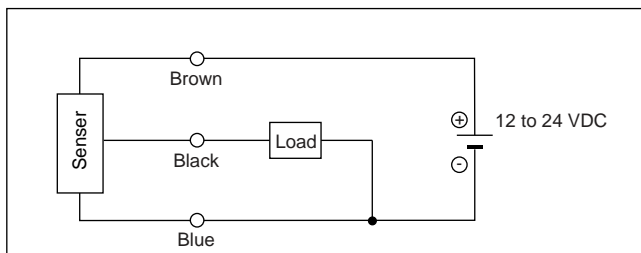

- Refrigerating type dryer
- Desiccant type dryer
- High polymer membrane dryer
- Air filter
- Auto. drain / others
- F.R.L. (Module unit)
- F.R.L. (Separate)
- Compact F.R.
- Precise regulator
- F.R.L. (Related products)
- Clean F.R.
- Electro pneumatic regulator
- Air booster
- Speed control valve
- Silencer
- Check valve / others
- Joint / tube
- Vacuum filter
- Vacuum regulator
- Suction plate
- Magnetic spring buffer
- Mechanical pressure SW
- Electronic pressure SW
- Contact / close contact cont. SW
- Air sensor
- Pressure SW for coolant
- Small flow sensor
- Small flow controller
- Flow sensor for air
- Flow sensor for water
- Total air system
- Total air system (Gamma)

Ending

Electronic pressure switch
Pressure sensor