

# Micro-miniature Flow Switch (Air and N2) RAPIFLOW® FSM-X Series

New Product



### Overview

Functions have been refined to be integrated into the equipment for increased miniaturization and weight reduction. Installation to the end of moving parts closest to the measuring section has been made possible for improved system responsiveness.

Bidirectional detection is made possible for value-added high function in a wide range of fields.

### Features

- Verifies mounting and removal of extremely small semiconductor chips (Also detects filter clogging and crushed nozzles.)



**Micro-miniature ultra light flow sensor. Only 8mm thin!**

### Specifications

Model No.		Analog output type							
Items		FSM-X-AR005	FSM-X-AR010	FSM-X-AR050	FSM-X-AR100	FSM-X-AF005	FSM-X-AF010	FSM-X-AF050	FSM-X-AF100
Flow rate range (l/min)		-0.5 to +0.5	-1 to +1	-5 to +5	-10 to +10	0 to 0.5	0 to 1	0 to 5	0 to 10
Working conditions	Working fluid	Compressed air (JIS B 8392-1.1.1 to 1.6.2) <sup>Note 1</sup> , N2 gas							
	Max. working pressure MPa	0.2							
	Min. working pressure MPa	-0.09							
	Withstanding pressure MPa	0.3							
	Ambient temperature/humidity	0 to 50°C, 80% RH or less							
	Working fluid temperature °C	0 to 50 (no freezing)							
Display		-							
Output	Note 2	Analog output (1 point) (1 to 5V voltage output, connected load impedance 50kΩ and over)							
Analog output accuracy	Linearity	Non-linear							
	Pressure characteristics Note 3	±5%F.S. or less				±10%F.S. or less			
	Temperature characteristics	±0.3%F.S./°C or less (0 to 50°C, 25°C standard)				±0.6%F.S./°C or less (0 to 50°C, 25°C standard)			
	Reproducibility (accuracy of repeatability)	±1%F.S. or less		±2%F.S. or less		±1%F.S. or less		±2%F.S. or less	
Responsiveness	Note 4	5ms or less			8ms or less		5ms or less		8ms or less
Power voltage		24VDC (21.6 to 26.4V) Ripple ratio 1% or less							
Power consumption		30mA or less							
Connector		SM03B-SRSS (made by JST MFG CO. LTD.) <sup>Note 5</sup>							
Installation attitude		Vertical or lateral as desired							
Vibration resistance		10 to 150Hz, compound amplitude 1.5mm, max. 10G, 2 hrs in each XYZ direction							
Weight	g	4 (sensor head)							

Note 1: Please refer to the compressed air quality classes according to JIS B 8392-1: 2003 listed in the "Pneumatic, Vacuum, and Auxiliary Components Catalog" (No. CB-024SA)

Note 2: The bilateral (unilateral) analog output will indicate 3V (1V) when the flow rate is 0. When the connector is on the right and fluid flows from left to right (as you're facing the unit), it changes to 5V.

Note 3: -0.09 to 0.2MPa, however the standard is 0.1MPa.

Note 4: According to the time of reaching 80% of the final voltage. Response time will vary depending on piping conditions.

Note 5: Applicable connectors (made by JST MFG CO. LTD.)

Contact: SSH-003T-P0.2-H  
Housing: SHR-03V-S



**Please read the safety precautions in the "Pneumatic, Vacuum, and Auxiliary Components Catalog" (No. CB-024SA) Small Size Flow Sensor RAPIFLOW® FSM-V Series before use.**

**CKD Corporation**

CC-1000A

## How to order

### ●Body

FSM-X - A F 005 - H04 - 3

Model No.

A Output type

B Flow direction

C Flow range

D Fitting type

### ●Option

FSM-X - C33

Cable

C33 Cable with connector (3-core, 3m)

Symbol	Descriptions
<b>A Output type</b>	
A	Analog output
<b>B Flow direction</b>	
F	Unidirectional
R	Bidirectional
<b>C Flow range</b>	
005	Full scale: 0.5l/min
010	Full scale: 1l/min
050	Full scale: 5l/min
100	Full scale: 10l/min
<b>D Fitting type</b>	
Blank	Sensor head (discrete component, w/o fitting)
H04	w/ Flowpath block (ø4mm push-in fitting)
M05	w/ Flowpath block (M5)
<b>E Cable</b>	
Blank	w/o Cable
3	Cable with connector (3-core, 3m)

## Dimensions

### ●Sensor head

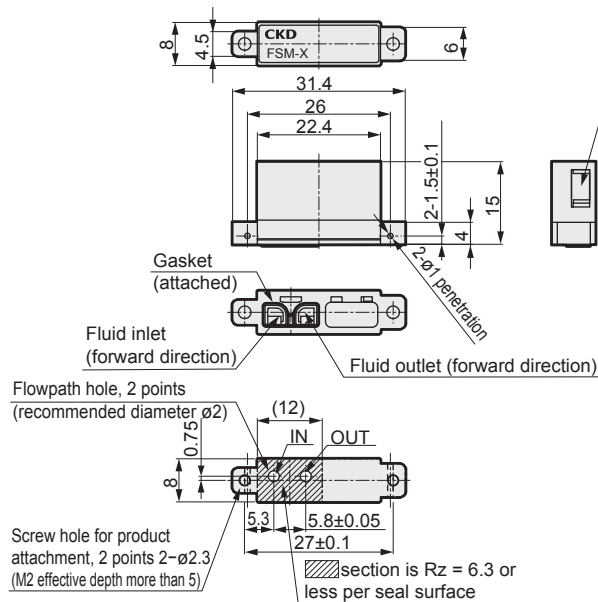

### ●Sensor head w/flowpath block

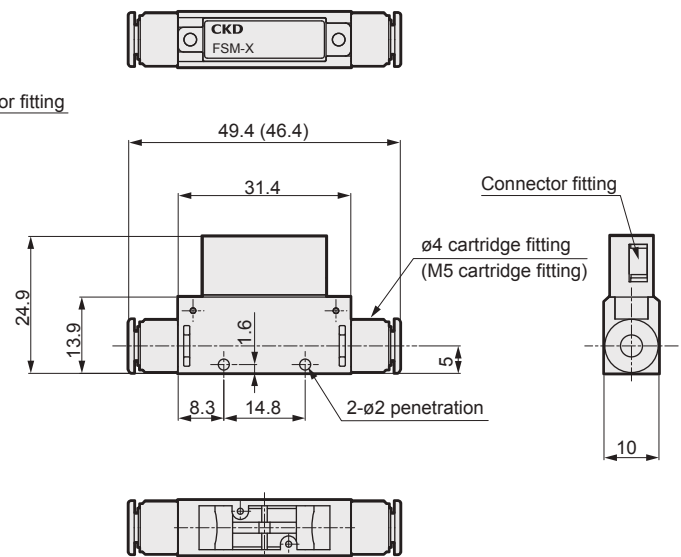

If the goods and their replicas, or the technology and software in this catalog are to be exported, laws require the exporter to make sure they will never be used for the development or the manufacture of weapons for mass destruction.

# CKD Corporation

<Website>  
<http://www.ckd.co.jp/>

Head Office+Plant 2-250, Uji, Komaki, Aichi 485-8551  
 Sales And Marketing Div. 2-250, Uji, Komaki, Aichi 485-8551  
 Overseas Sales Administration dpt. 2-250, Uji, Komaki, Aichi 485-8551  
 Overseas Business div.  
 Tokyo Branch Office 4F, Bunkahousou Media Plus, 1-31-1, Hamamatsu-cho, Minato-ku, Tokyo 105-0013  
 Nagoya Branch Office 2-250, Uji, Komaki, Aichi 485-8551  
 Osaka Branch Office 1-3-20, Tosabori, Nishi-ku, Osaka 550-0001

TEL(0568)77-1111 FAX(0568)77-1123  
 TEL(0568)74-1303 FAX(0568)77-3410  
 TEL(0568)74-1338 FAX(0568)77-3461  
 TEL(03)5402-3620 FAX(03)5402-0120  
 TEL(0568)74-1356 FAX(0568)77-3317  
 TEL(06)6459-5770 FAX(06)6446-1945

●Specifications are subject to change without notice.  
 © CKD Corporation 2011 All copy rights reserved.