



Precision regulator

RP2000 Series

● Port size: Rc1/4 Rc3/8

JIS symbol



Specifications

Descriptions	RP2000-8-08	RP2000-10-08
Working fluid	Compressed clean air (refer to recommended air circuit on page 453)	
Max. working pressure	MPa	1.0 (≈150 psi, 10 bar)
Min. working pressure	MPa	Set pressure +0.1 (≈15 psi, 1 bar) *1
Proof pressure	MPa	1.5 (≈220 psi, 15 bar)
Ambient / fluid temperatures	°C	-5 (23°F) to 60 (140°F) (no freezing) *3
Set pressure	MPa	0.03 (≈4.4 psi, 0.3 bar) to 0.85 (≈120 psi, 8.5 bar)
Sensitivity		Within 0.2% of full scale
Repeatability		Within ±0.5% of full scale
Air consumption	ℓ/min(ANR)	5 or less *2
Port size	Rc1/4	Rc3/8
Exhaust side port size		Rc3/8
Pressure gauge port size		Rc1/8
Weight	g	470

*1: Flow rate of the secondary side is to be zero.

*2: Conditions where the primary pressure is 0.7 MPa and set pressure is 0.3 MPa. Consumed air is normally released to the atmosphere from the bleed port and EXH port. So, air consumption is the total of consumption volume released from the bleed port and EXH port. Air 1 ℓ/min. (ANR) or less is released from EXH port.

*3: The range is -5 to 50°C when a digital pressure sensor is used.

How to order

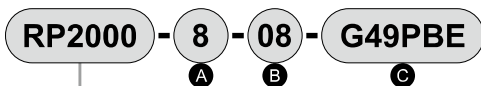

Model
RP2000: Precision regulator

A Port size		B Set pressure range		C Other attachments	
8	Rc1/4	08	MAX.0.85 MPa	Blank	Without attachment
10	Rc3/8			G49P	Pressure gauge
				B	C type bracket
				E	Silencer
				R2	Digital pressure sensor

*1: If an Rc1/2 port size is required, use a pipe adaptor set (model No.: A400-15-W).

*2: Attachment is attached.

*3: The pipe adaptor set and C type bracket cannot be used together.

*4: One R1/8 plug is enclosed with the product.

Discrete attachment model No.

Attachment code	Discrete attachment model No.
G49P	G49D-6-P10
B	B220
E	SLW-10A
R2	PPX-R10N-6M

Clean-room specifications (Catalog No. CB-033SA)

● Anti-dust generation structure for use in cleanrooms

RP2000 - - P70

Specifications for rechargeable battery (Catalog No. CC-1226A)

● Structure compatible with rechargeable battery manufacturing process

RP2000-..... - P4*

Internal structure and parts list

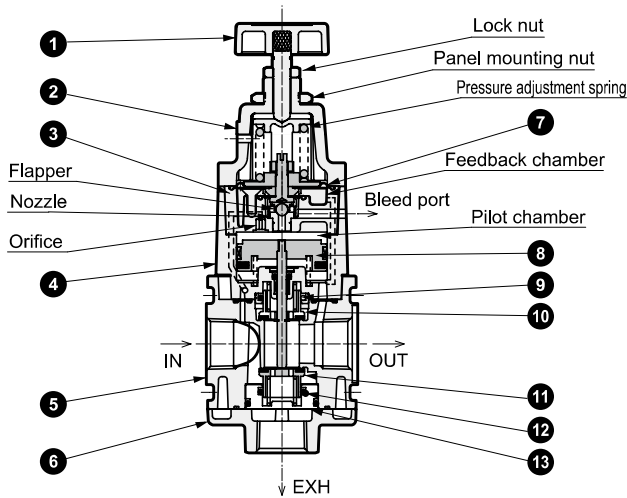

No.	Part name	Material
1	Pressure adjustment knob	Polyacetal resin, stainless steel
2	Cover	Aluminum alloy die-casting
3	Pilot body assembly	Aluminum alloy die-casting, etc.
4	Top body assembly	Aluminum alloy die-casting, etc.
5	Body	Aluminum alloy die-casting
6	Exhaust adaptor	Aluminum alloy die-casting
7	Pilot diaphragm	Hydrogenated nitrile rubber
8	Piston assembly	Aluminum, stainless steel, etc.
9	O-ring	Nitrile rubber
10	Exhaust valve	Copper alloy, hydrogenated nitrile rubber
11	Air supply valve	Copper alloy, hydrogenated nitrile rubber
12	O-ring	Nitrile rubber
13	Bottom cap	Copper alloy

Operational explanation

Air supplied from IN side is stopped its flow to OUT side by the air supply valve. Some supplied air passes through the orifice to flow into the pilot chamber.

When the ① pressure adjustment knob is rotated, the pressure adjustment spring is compressed, and the ⑦ pilot diaphragm and the flapper are pushed down to close the nozzle.

Pressure in the pilot chamber rises, forcing the piston lower to open the ⑪ air supply valve, and to supply air to OUT side. The intake air flows into the feedback chamber, and works on the ⑦ pilot diaphragm. If the diaphragm is forced upward until the air reaches the pressure of the regulator spring, the ⑦ pilot diaphragm and flapper are forced upward to open the nozzle, and an extremely small amount of air is released to the atmosphere to reduce pressure in the pilot chamber. At the same time, the OUT side pressure works on the piston to force it upward, the ⑪ air supply valve is closed and the set pressure is maintained.

When the air is consumed and the pressure drops on the OUT side, the pressure in the feedback chamber also drops. The ⑦ pilot diaphragm and the flapper are forced lower to close the nozzle. Pressure in the pilot chamber rises, causing the piston to open the ⑪ air supply valve, compensating for any drop in pressure.

If the OUT side pressure increases further than the set pressure, the pressure in the feedback chamber also increases. The ⑦ pilot diaphragm and the flapper are forced upward to open the nozzle. This allows the pressure in the pilot chamber to decrease, and the piston is forced upward to open the ⑩ exhaust valve; the surplus pressure is pumped from EXH port on the OUT side to the atmosphere. This pilot pressure control method using the nozzle and flapper can follow up a minimal pressure change, which enables the high precision pressure control.

Repair parts list

No.	Part name	Model No.
3	Pilot body assembly	RP2000-PILOT-ASSY
7	Pilot diaphragm	
4	Top body assembly	RP2000-TOP-BODY-ASSY
11	Air supply valve	RP2000-BTM-VALVE-ASSY
12	O-ring	
13	Bottom cap	

Note: Parts No. (8), (9), (10) are contained in the top body assembly (4)

Dimensions

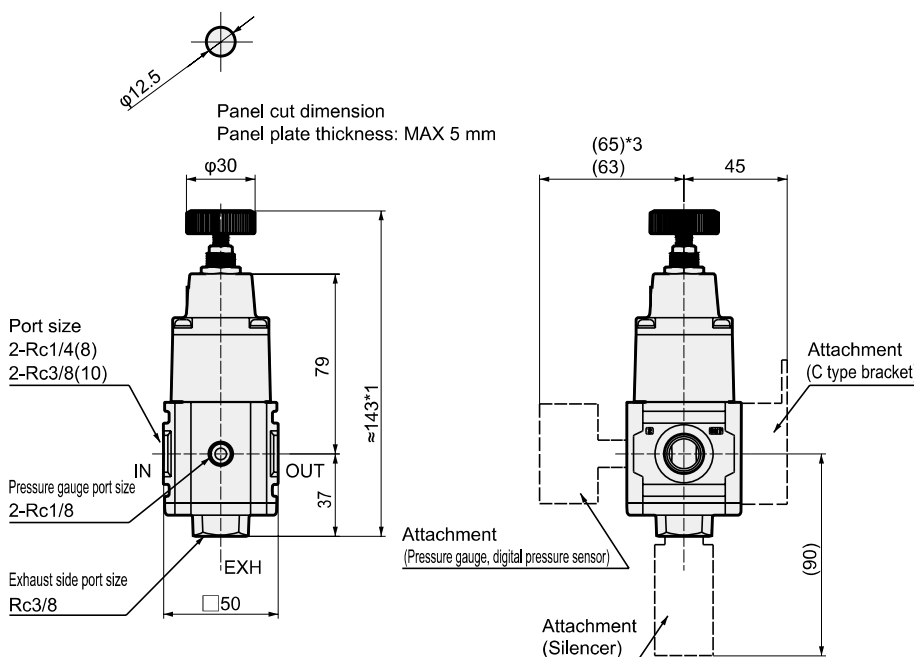

*1: Dimensions at the setting pressure of 0 MPa
 *2: Pressure gauge, digital pressure sensor, C type bracket and silencer are optionally included.
 *3: Dimensions when the digital pressure sensor is assembled.

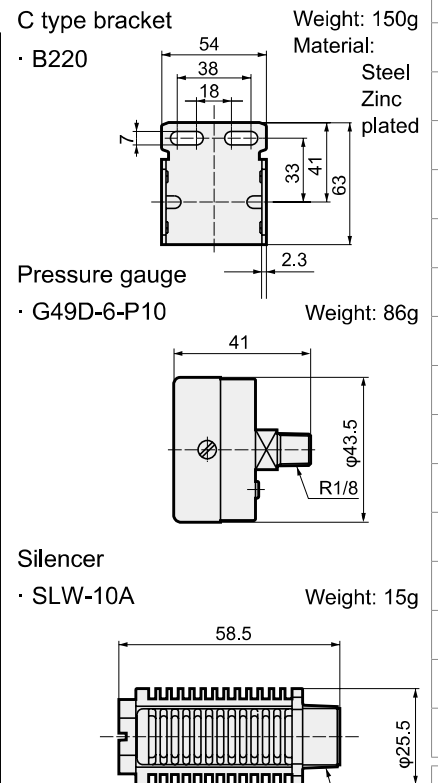

F.R.L
F (Filtr)
R (Reg)
L (Lub)
PresSW
Shutoff
SlowStart
FilmResistFR
Oil-ProHR
MedPresFR
No Cu/ PTFE FRL
Outdrs FR
F.R.L (Related)
CompFRL
LgFRL
PresCR
VacF/R
Clean FR
ElecPneuR
AirBoost
SpdContr
Silncr
CheckV/ other
Jnt/tube
AirUnt
PresCompn
Mech/ ElecPresSw
ContactSW
AirSens
PresSW Cool
AirFloSens/ Contr
WaterRiSens
TotAirSys (Total Air)
TotAirSys (Gamma)
RefrDry
DesicDry
HiPolymDry
MainFiltr
Dischrg etc
Ending

RP2000 Series

- F.R.L
- F (Filtr)
- R (Reg)
- L (Lub)
- PresSW
- Shutoff
- SlowStart
- FilmResistFR
- Oil-ProhR
- MedPresFR
- No Cu/
PTFE FRL
- Outdrs FR
- F.R.L
(Related)
- CompFRL
- LgFRL
- PrecsR
- VacF/R
- Clean FR
- ElecPneuR
- AirBoost
- SpdContr
- Silncr
- CheckV/
other
- Jnt/tube
- AirUnt
- PrecsCompn
- Mech/
ElecPresSw
- ContactSW
- AirSens
- PresSW
Cool
- AirFloSens/
Contr
- WaterRiSens
- TotAirSys
(Total Air)
- TotAirSys
(Gamma)
- RefrDry
- DesicDry
- HiPolymDry
- MainFiltr
- Dischrg
etc
- Ending

Dimensions

● PPX-R10N-6M

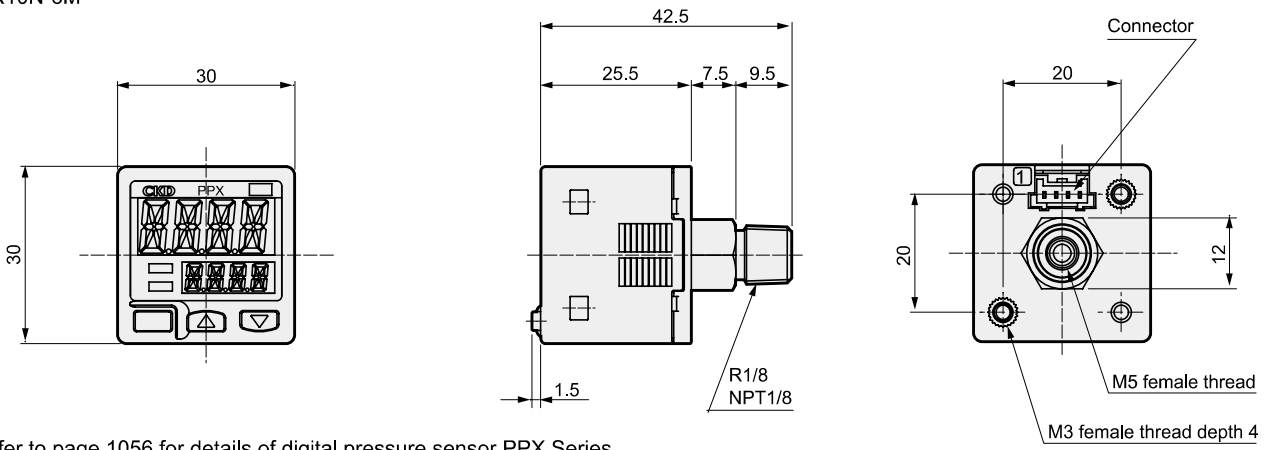

Note: Refer to page 1056 for details of digital pressure sensor PPX Series.

Weight: 40g

Flow characteristics

● RP2000-10-08

Primary pressure 0.7 MPa

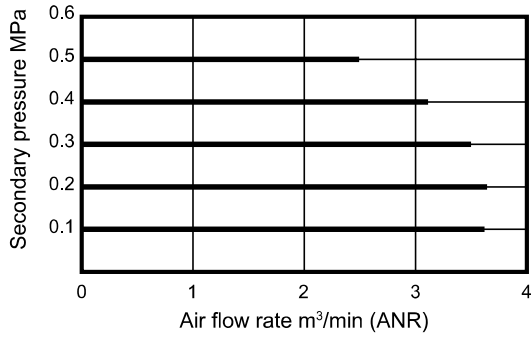

● RP2000-8-08

Primary pressure 0.7 MPa

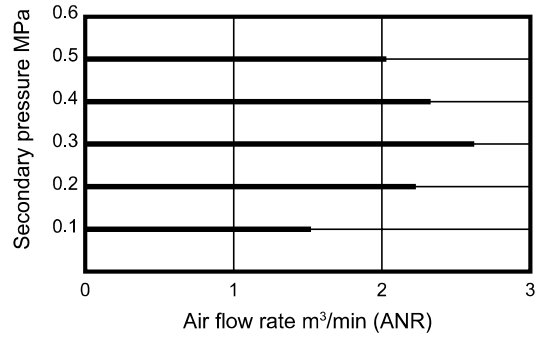

Relief flow characteristics

● RP2000-10-08

Primary pressure 0.7 MPa

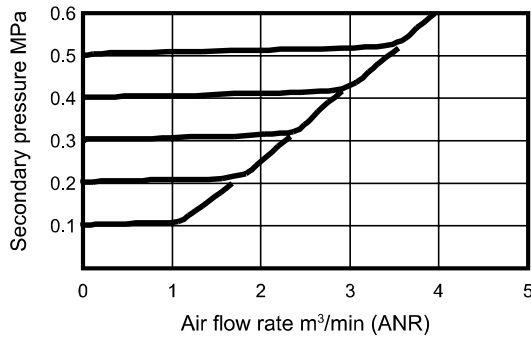

● RP2000-8-08

Primary pressure 0.7 MPa

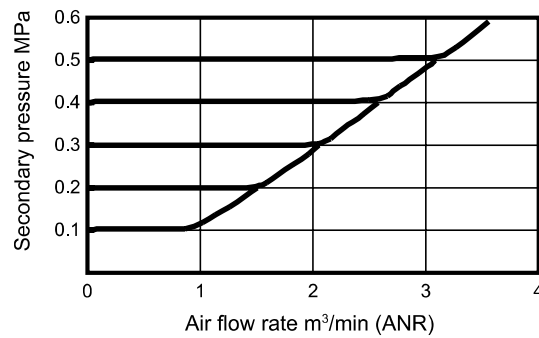

Pressure characteristics

● RP2000-*-08

Secondary side flow rate 0 l/min

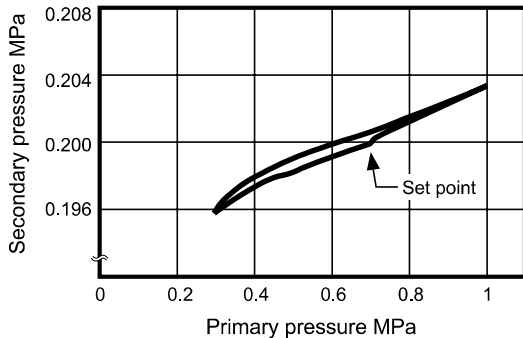

Cylinder speed range of RP2000

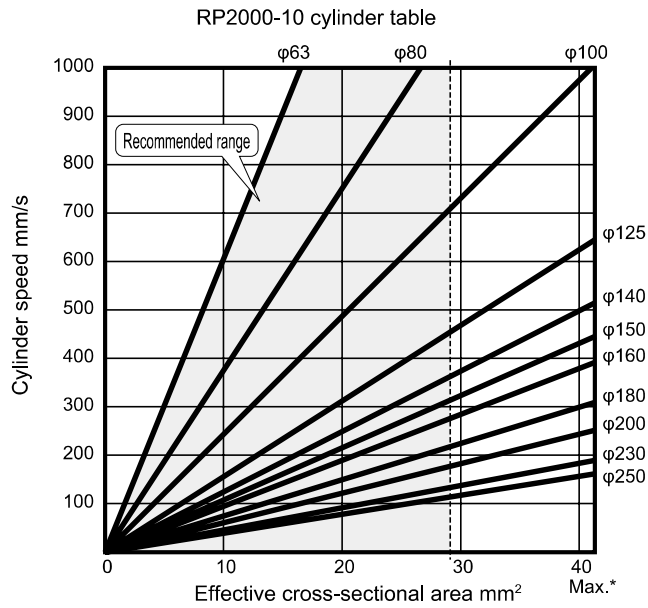

This cylinder table shows the available range according to the air supply and exhaust flow rate of the precision regulator and the required consumption flow rate at the cylinder PUSH/PULL.

----- Recommended cylinder line
(70% of max. flow rate is recommended)
* Max. cylinder line
(Cylinder directly installed)

Example of precise pressure control system

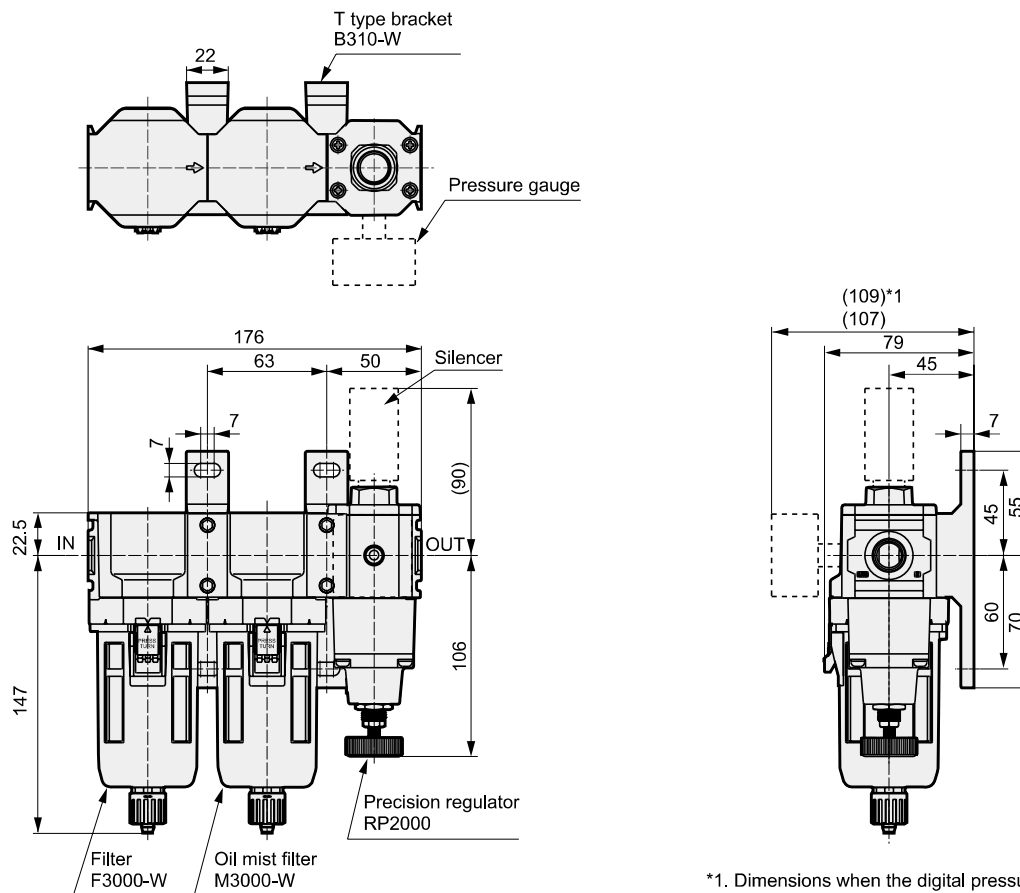

*1. Dimensions when the digital pressure sensor is assembled.

* Contact CKD if required for assembly.

Compatible model	Filter	Oil mist filter	Precision regulator	T type bracket set
Product model No.	F3000-W	M3000-W	RP2000	B310-W (2 pcs.)

- F.R.L
- F (Filtr)
- R (Reg)
- L (Lub)
- PresSW
- Shutoff
- SlowStart
- FlnResistFR
- Oil-ProhR
- MedPresFR
- No Cu/ PTFE FRL
- Outdrs FR
- F.R.L (Related)
- CompFRL
- LgFRL
- PresCR**
- VacF/R
- Clean FR
- ElecPneuR
- AirBoost
- SpdContr
- Silncr
- CheckV/ other
- Jnt/tube
- AirUnt
- PresCompn
- Mech/ ElecPresSw
- ContactSW
- AirSens
- PresSW Cool
- AirFloSens/ Contr
- WaterRiSens
- TotAirSys (Total Air)
- TotAirSys (Gamma)
- RefrDry
- DesicDry
- HiPolymDry
- MainFiltr
- Dischrg etc
- Ending

Applications

Fluid discharge control

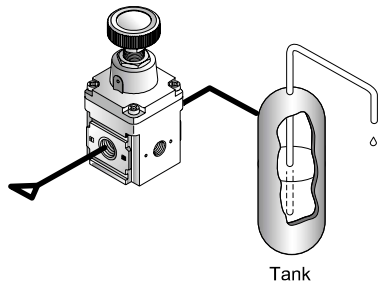

Balance

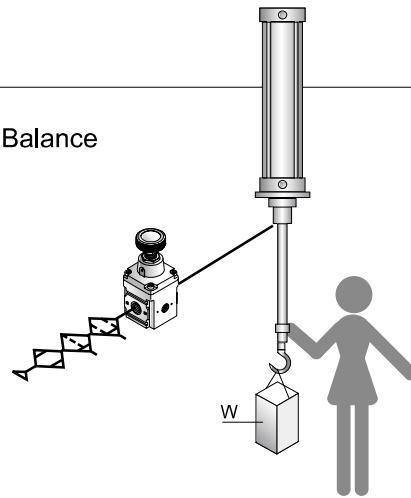

Pilot pressure control

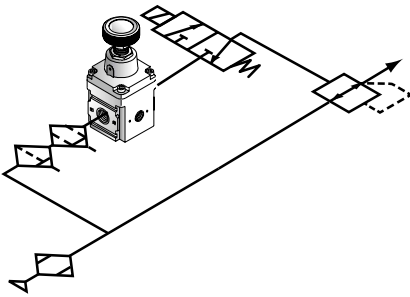

Very low pressure blow

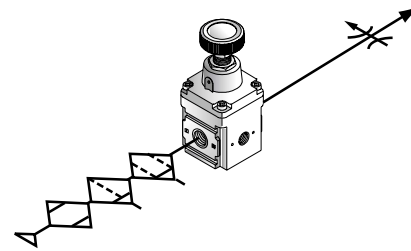

Quick pressure regulation of tank pressure

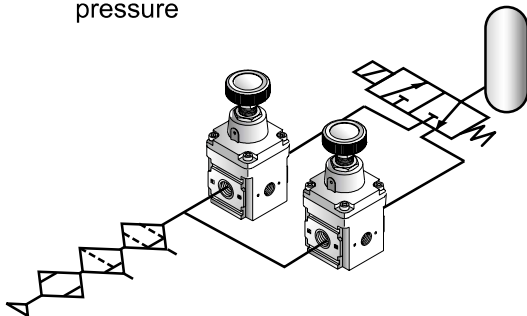

Leakage test

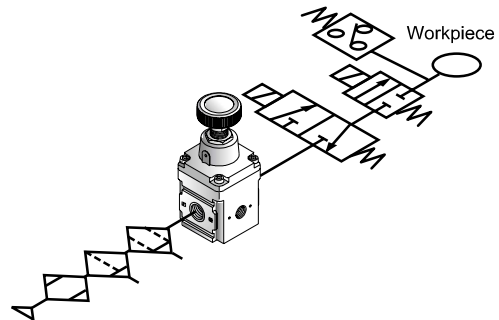

Tension control

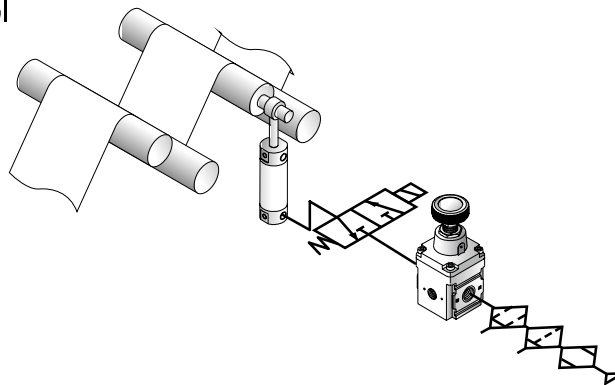

- F.R.L
- F (Filtr)
- R (Reg)
- L (Lub)
- PresSW
- Shutoff
- SlowStart
- FimResistFR
- Oil-ProhR
- MedPresFR
- No Cu/PTFE FRL
- Outdrs FR
- F.R.L (Related)
- CompFRL
- LgFRL
- PrecsR**
- VacF/R
- Clean FR
- ElecPneuR
- AirBoost
- SpdContr
- Silncr
- CheckV/other
- Jnt/tube
- AirUnt
- PrecsCompn
- Mech/ElecPresSw
- ContactSW
- AirSens
- PresSW Cool
- AirFloSens/Contr
- WaterRiSens
- TotAirSys (Total Air)
- TotAirSys (Gamma)
- RefrDry
- DesicDry
- HiPolymDry
- MainFiltr
- Dischrg etc
- Ending



Pneumatic components (F.R.L. unit (precision))

Safety Precautions

Be sure to read this section before use.

Refer to Intro Page 63 for precautions for general pneumatic components.

Product-specific cautions: Precision regulator RP1000/2000 Series

Design/selection

⚠ WARNING

- Use the product in the range of conditions specified for the product.
- Working fluid must be clean air from which solids, water and oil have been sufficiently removed using a dryer, filter and oil mist filter. Never supply oiled air.
As well, when secondary side pressure, etc., is turned OFF, air on the secondary side will pass through the regulator and be discharged from the EXH port. Thus, if secondary piping or load side interior is dirty, malfunction, characteristics deterioration, etc., may occur. Keep the inside of the pipes clean.

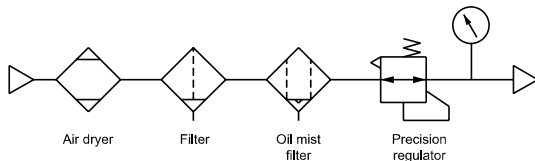

⚠ CAUTION

- Keep the pressure difference between the primary and secondary sides to 0.1 MPa or more. For RP1000-8-04, if the set pressure is 0.3 MPa or over, keep the pressure difference at 0.2 MPa or over. (Precautions for RP1000)
When using under conditions where a small pressure difference exists between the primary and secondary sides, the secondary side pressure may pulsate. In this case, increase the secondary side capacity before use. Or set pressure in the depressurizing direction (high pressure → low pressure). Another method is to set the primary pressure to an extremely high level or to somewhat lower the setting pressure, and restrict the secondary side line. If pulsation continues, contact CKD. When using with a low friction cylinder having constant leakage, the secondary pressure may pulsate depending on the working conditions. In this case, restrict the secondary side line and decrease the pressure setting (high pressure → low pressure) to attenuate pulsation. Consult with CKD if the pulsation still does not cease.
(Precautions for RP2000)
If the pressure difference between the primary and secondary sides is large and secondary side piping is large, secondary pressure could pulsate during low flow. In this case, set the primary side to the secondary side pressure +0.1 to 0.2 MPa or restrict the secondary side line. If pulsation continues, contact CKD.
- If the regulator is repeatedly turned ON and OFF with the directional switching valve on the primary side, the set pressure may change greatly. Thus, the directional switching valve should be installed on the secondary side.
- Output pressure exceeding the regulator's set pressure could result in damage or faulty operation of the secondary side devices. Be sure to install a safety device.
- Do not operate the pressure adjustment knob while the primary side is released to the atmosphere, as performance could deteriorate.

Mounting, installation and adjustment

⚠ CAUTION

- Check IN and OUT indications indicating the air inlet and outlet before connecting. A reverse connection could result in improper operation.
- Do not move or swing the product by the pressure adjustment knob.
- Do not install this product in a location where it may be subject to vibrations or shocks.
- Flush air pipes before connecting the regulator.

- Use sealing tape when piping. Do not use liquid and solid sealant. In addition, ensure that the sealing tape does not enter.
- When using in parallel as shown below, do not use the secondary side as a closed circuit. If a closed circuit is required, be sure to set a check valve on the secondary side.

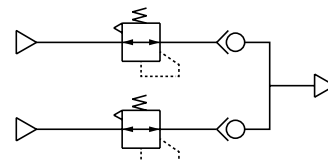

CKD

F.R.L
F (Filtr)
R (Reg)
L (Lub)
PresSW
Shutoff
SlowStart
FlnResistFR
Oil-ProhR
MedPresFR
No Cu/ PTFE FRL
Outdrs FR
F.R.L (Related)
CompFRL
LgFRL
PresR
VacF/R
Clean FR
ElecPneUR
AirBoost
SpdContr
Silncr
CheckV/ other
Jnt/tube
AirUnt
PresCompn
Mech/ ElecPresSw
ContactSW
AirSens
PresSW Cool
AirFloSens/ Contr
WaterRtSens
TotAirSys (Total Air)
TotAirSys (Gamma)
RefrDry
DesicDry
HiPolymDry
MainFiltr
Dischrg etc
Ending

- F.R.L
- F (Filtr)
- R (Reg)
- L (Lub)
- PresSW
- Shutoff
- SlowStart
- FilmResistFR
- Oil-ProhR
- MedPresFR
- No Cu/PTFE FRL
- Outdrs FR
- F.R.L (Related)
- CompFRL
- LgFRL
- PrecsR
- VacFR
- Clean FR
- ElecPneuR
- AirBoost
- SpdContr
- Silncr
- CheckV/other
- Jnt/tube
- AirUnt
- PrecsCompn
- Mech/ElecPresSw
- ContactSW
- AirSens
- PresSW Cool
- AirFloSens/Contr
- WaterRiSens
- TotAirSys (Total Air)
- TotAirSys (Gamma)
- RefrDry
- DesicDry
- HiPolymDry
- MainFiltr
- Dischrg etc
- Ending

- Install so that the EXH port is not plugged.
- When installing on a panel, completely loosen and remove the pressure adjustment knob, insert the body into the $\phi 12.5$ panel hole, and fix it to the panel with the panel mounting nut. Then, turn the pressure adjustment knob to attach it to the body. Panel mounting nut recommended tightening torque 2 to 3N·m
[Precautions for RP2000]
If the product is installed horizontally with the panel mounting nut, the panel could be damaged by the weight of the product and vibration.

- Use appropriate torque to tighten the pipes when connecting them.
 - The purpose is to prevent air leakage and damage to bolts.
 - First tighten the bolts by hand to ensure that the threads are not damaged, then use a tool.

[Recommended values]

Port thread	Tightening torque N·m
Rc1/8	3 to 5
Rc1/4	6 to 8
Rc3/8	13 to 15

During use/maintenance

⚠ CAUTION

■ Working air quality

- Use only compressed air. Air containing corrosive gases, fluids or chemicals could result in improper pressure adjustment due to body damage or rubber deterioration.

■ Working environment

- Avoid use in the following environments.
 - When ambient temperature exceeds the range of -5 to 60°C.
 - Where air freezes.
 - Places where the unit will be exposed to dripping water and/or cutting oil.
 - Highly humid places where dew condenses due to temperature fluctuations.
 - Where salt air or splashing seawater contacts the product.
 - In atmospheres containing corrosive gases, liquids and chemicals.
 - Where the product is exposed to direct sunlight.
- With the precision regulator RP1000, the set pressure fluctuates by approx. 0.12 kPa/°C. The pressure tends to drop when the temperature rises.

■ Precautions for use

- Air constantly leaks from the bleed port. This is necessary for precise pressure control, so do not plug the hole.
- Check primary pressure before setting pressure.
- Pressure higher than the primary pressure cannot be set.
- Turn the pressure adjustment knob clockwise to increase secondary pressure, and counterclockwise to lower pressure.
- Pressure is set in the depressurizing direction (high pressure → low pressure), enabling highly precise setting to be made.
- After adjusting pressure, tighten the lock nut, and then fix the knob.
- The precision regulator RP1000 exhaust valve has a metal seal, so a small amount of secondary side air will leak.

■ Maintenance precautions

- Pneumatic components must be disassembled and assembled by qualified personnel.
- Pneumatic Pressure Skill Test Class 2 or higher level is required.
- Read the relevant product instruction manual thoroughly and fully familiarize yourself with the task before disassembling or assembling pneumatic components.
- Personnel must be fully familiar with pneumatic component structure and operational principles and safety requirements.
- Before conducting maintenance, turn the power OFF, stop the supply of compressed air and make sure that there is no residual pressure.

