

Series variation

Medium bore size cylinder CMK2 Series

● : Standard ○ : Option ○ : Custom order ■ : Not available

SCP*2
CMK2
CMA2
SCM
SCG
SCA2
SCS
CKV2
CA/OV2
SSD
CAT
MDC2
MVC
SMD2
MSD*
FC*
STK
ULK*
JSK/M2
JSG
JSC3
USSD
USC
JSB3
LMB
STG
STS/L
LCS
LCG
LCM
LCT
LCY
STR2
UCA2
HCM
HCA
SRL2
SRG
SRM
SRT
MRL2
MRG2
SM-25
CAC3
UCAC
RCC2
MFC
SHC
GLC
Ending

SCP*2
CMK2
CMA2
SCM
SCG
SCA2
SCS
CKV2
CA/OV2
SSD
CAT
MDC2
MVC
SMD2
MSD*
FC*
STK
ULK*
JSK/M2
JSG
JSC3
USSD
USC
JSB3
LMB
STG
STS/L
LCS
LCG
LCM
LCT
LCY
STR2
UCA2
HCM
HCA
SRL2
SRG
SRM
SRT
MRL2
MRG2
SM-25
CAC3
UCAC
RCC2
MFC
SHC
GLC
Ending

Medium bore size cylinder
Standard type

Variation	Model no. JIS symbol	Bore size (mm)	Standard stroke length (mm)										Min. stroke length (mm)	Max. stroke length (mm)	Custom stroke length (per mm)	Mounting style										Option								Accessory				Switch	Page				
																Basic type	Axial foot type both sides	Axial foot type single	Rod side flange type	Head side flange type	Eye bracket type	Fixed eye	Eye bush press fitted type	Clevvis bracket type	Rod side trunnion type	Head side trunnion type	Bellows(100℃)	Bellows(250℃)	Push-in joint straight	Push-in joint elbow	Piston rod material change	Boss cut off	Copper and PTFE free	Rod eye	Rod clevis	Clevvis bracket							
			25	50	75	100	150	200	250	300	00	LB																									LS			FA	FB	CA	CC
Double acting	CMK2	φ20, φ25, φ32, φ40	●	●	●	●	●	●	●	●	●	5	750	1	●	●	●	●	●	●	●	●	●	●	●	●	○	○	○	○	○	○	○	○	○	○	○	○	○	○	90		
Single acting extend type	CMK2-S	φ20, φ25	●	●	●	●	●	■	■	■	■	5	300	1	●	●	●	●	●	●	●	●	●	●	●	○	○	○	○	○	○	○	○	○	○	○	○	○	○	○	○	102	
		φ32, φ40	●	●	●	●	●	●	○	○	○	○	300	300	●	●	●	●	●	●	●	●	●	●	○	○	○	○	○	○	○	○	○	○	○	○	○	○	○	○	○		
Single acting retract type	CMK2-SR	φ20, φ25	●	●	●	●	●	■	■	■	■	5	300	1	●	●	●	●	●	●	●	●	●	●	●	○	○	○	○	○	○	○	○	○	○	○	○	○	○	○	○	108	
		φ32, φ40	●	●	●	●	●	●	●	○	○	○	300	300	●	●	●	●	●	●	●	●	●	●	○	○	○	○	○	○	○	○	○	○	○	○	○	○	○	○	○		
Double acting stroke adjustable type (extended)	CMK2-P	φ20, φ25	●	●	●	●	●	●	●	●	●	25	450	1	●	●	●	●	●	■	■	■	■	■	■	○	○	○	○	○	○	○	○	○	○	○	○	○	○	○	○	114	
		φ32	●	●	●	●	●	●	●	●	●	430	430	●	●	●	●	●	●	●	●	●	●	○	○	○	○	○	○	○	○	○	○	○	○	○	○	○	○	○	○		
		φ40	●	●	●	●	●	●	●	●	●	400	400	●	●	●	●	●	●	●	●	●	●	○	○	○	○	○	○	○	○	○	○	○	○	○	○	○	○	○	○		○
Double acting stroke adjustable type (retracted)	CMK2-R	φ20, φ25, φ32, φ40	●	●	●	●	●	●	●	●	25	750	1	●	●	●	●	●	●	■	■	■	■	■	○	○	○	○	○	○	○	○	○	○	○	○	○	○	○	○	○	120	
Double acting heat resistance type	CMK2-T	φ20, φ25, φ32, φ40	●	●	●	●	●	●	●	●	5	750	1	●	●	●	●	●	●	●	●	●	●	●	○	○	○	○	○	○	○	○	○	○	○	○	○	○	○	○	○	126	
Double acting rubber-air cushioned	CMK2-*C	φ20, φ25, φ32, φ40	●	●	●	●	●	●	●	●	5	750	1	●	●	●	●	●	●	●	●	●	●	●	○	○	○	○	○	○	○	○	○	○	○	○	○	○	○	○	○	130	
Double acting air cushioned	CMK2-C	φ20, φ25, φ32, φ40	●	●	●	●	●	●	●	●	5	750	1	●	●	●	●	●	●	●	●	●	●	●	○	○	○	○	○	○	○	○	○	○	○	○	○	○	○	○	○	138	
Double acting position locking type	CMK2-Q	φ20, φ25, φ32, φ40	●	●	●	●	●	●	●	●	5	750	1	●	●	●	●	●	●	●	●	●	○	○	○	○	○	○	○	○	○	○	○	○	○	○	○	○	○	○	○	144	
Double acting fine speed type	CMK2-F	φ20, φ25, φ32, φ40	●	●	●	●	●	●	●	●	5	750	1	●	●	●	●	●	●	●	●	●	○	○	○	○	○	○	○	○	○	○	○	○	○	○	○	○	○	○	○	○	150
Double acting double rod type	CMK2-D	φ20, φ25	●	●	●	●	●	●	●	●	500	500		●	●	●	●	●	●	●	●	●	●	○	○	○	○	○	○	○	○	○	○	○	○	○	○	○	○	○	○	154	
		φ32	●	●	●	●	●	●	●	●	5	480	1	●	●	●	●	●	●	●	●	●	○	○	○	○	○	○	○	○	○	○	○	○	○	○	○	○	○	○	○		
		φ40	●	●	●	●	●	●	●	●	450	450		●	●	●	●	●	●	●	●	●	○	○	○	○	○	○	○	○	○	○	○	○	○	○	○	○	○	○	○		○
Double acting back to back type	CMK2-B	φ20, φ25, φ32, φ40	●	●	●	●	●	●	●	●	5	750	1	●	●	●	●	●	●	●	●	●	●	○	○	○	○	○	○	○	○	○	○	○	○	○	○	○	○	○	○	160	
Double acting non-rotating type	CMK2-M	φ20, φ25, φ32, φ40	●	●	●	●	●	●	●	●	5	750	1	●	●	●	●	●	●	●	●	●	●	●	○	○	○	○	○	○	○	○	○	○	○	○	○	○	○	○	○	○	166
Double acting flow control valve integrated type	CMK2-Z	φ20, φ25, φ32, φ40	●	●	●	●	●	●	●	●	5	750	1	●	●	●	●	●	●	●	●	○	○	○	○	○	○	○	○	○	○	○	○	○	○	○	○	○	○	○	○	172	
Double acting low hydraulic type	CMK2-H	φ20, φ25, φ32, φ40	●	●	●	●	●	●	●	●	5	750	1	●	●	●	●	●	●	●	●	●	○	○	○	○	○	○	○	○	○	○	○	○	○	○	○	○	○	○	○	○	178
Double acting coolant proof type	CMK2-G2/G3	φ20, φ25, φ32, φ40	●	●	●	●	●	●	●	●	5	750	1	●	●	●	●	●	●	●	●	●	○	○	○	○	○	○	○	○	○	○	○	○	○	○	○	○	○	○	○	○	182

Note 1: Available when rod side position locking is selected. Note 2: Available when head side position locking is selected. Note 3: Available for G2.

Variation and option selection table

○ : Option
○ : Manufacturing available (custom order)
△ : Available depending on conditions (consult with CKD.)
X : Not available

Table with columns: Code, Variation, Port thread, Cushion, Option. Rows include various cylinder types (Double acting, Single acting, etc.), port types (NPT, G, etc.), cushion types (Rubber-air, etc.), and options (Clean room specifications, etc.).

Cautions

- Note 1: Designate the cylinder on which the position locking mechanism is mounted. Designate either the rod side or head side. (Indicate with a sketch.)
Note 2: Designate the cylinder on which the baffle is mounted.
Note 3: A cushion can be attached on the cover on which the position locking mechanism is not mounted. (Example: With the CMK2-Q-32-ST-H, the cushion is attached to the rod side.)
Note 4: Friction resistance is high compared to the standard low speed (or fine speed).
Note 5: Low-speed performance cannot be satisfied in the cushion area at the stroke end.
Note 6: Compatible with a working temperature of 100°C or less.
Note 7: Low-speed performance may not be satisfied because of the bellows reaction force.
Note 8: The compatibility of the solvent or coolant that splatters onto the cylinder and bellows must be confirmed.
Note 9: Only the type with rod side position locking is available.
Note 10: For G2, G3 and P7, P71, the piston rod and nut materials are stainless steel (M). (The M symbol is not required.)
Note 11: For the non-rotating type, the piston rod material is stainless steel. (If M is selected, the rod nut will also be made of stainless steel.)
Note 12: Refer to the "Clean Component System" (Catalog No. CB-033SA) for details on the new fine type P7 and P71.
Note 13: Available only for the head side position locking type.

<Example of model number>

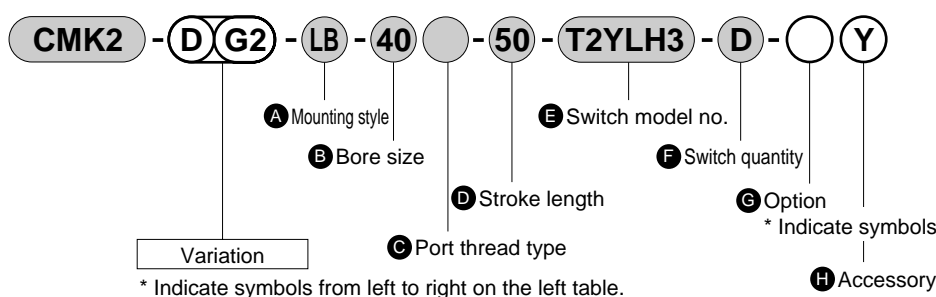

Model no.: Double acting standard type

- Variation: Double rod, coolant proof scraper type
- **A** Mounting style: Both sides foot type
- **B** Bore size: ϕ 40 mm
- **C** Port thread type: Rc thread
- **D** Stroke length: 50 mm
- **E** Switch model no.: Coolant proof, lead wire length 3 m.
- **F** Switch quantity: 2 piece
- **G** Option: None
- **H** Accessory: Rod clevis

Note 1: The back to back type has two cylinders. Use the method below to instruct the variation for each cylinder.

When variations are added only to S1, insert the variation symbol before the S1 stroke.

Example: CMK2-B-32-H25-50: Only S1 is low hydraulic.

When variations are added only to S2, insert the variation symbol before the S2 stroke.

Example: CMK2-B-32-25-50: Only S2 is low hydraulic.

When the same variations are added to both S1 and S2, insert the variation symbol before the port size.

Example: CMK2-BH-32-25-50: Both S1 and S2 are low hydraulic.

SCP*2
CMK2
CMA2
SCM
SCG
SCA2
SCS
CKV2
CA/OV2
SSD
CAT
MDC2
MVC
SMD2
MSD*
FC*
STK
ULK*
JSK/M2
JSG
JSC3
USSD
USC
JSB3
LMB
STG
STS/L
LCS
LCG
LCM
LCT
LCY
STR2
UCA2
HCM
HCA
SRL2
SRG
SRM
SRT
MRL2
MRG2
SM-25
CAC3
UCAC
RCC2
MFC
SHC
GLC
Ending

Medium bore size cylinder
Standard type



Safety precautions

Always read this section before starting use.

Refer to Intro 71 for general notes of cylinders and Intro 78 for cylinder switches.

Medium bore size cylinder CMK2 Series

Design & Selection

1. Fine speed type CMK2-F

CAUTION

■ Use this product without lubrication.

- Lubrication may change characteristics.

■ Install a flow control valve close to a cylinder.

- If this is installed away from a cylinder, adjustment will be unstable.
- Use flow control valves such as SC-M3/M5, SC3W, SCD-M3/M5, SC3WU Series.

■ In general, higher air pressure and smaller load factor results in more stable operation.

- Load factor should be 50% or less.

■ Stable speed control is achieved with a meter-out circuit.

- When driving the single rod cylinder at fine speed with the operation direction set to PUSH, popping out may occur if operation is started when load resistance is small. Install (b), (c), or (d) circuit to prevent this. The (d) circuit results in the most stable operation.

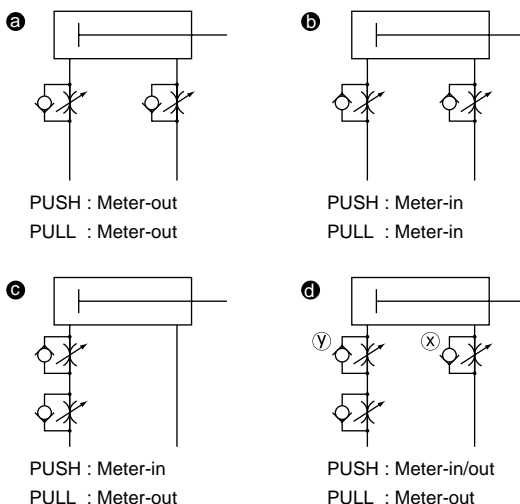

④ Speed adjustment method of PUSH operation of circuit:

1. Speed adjustment by flow control valve x.
2. Lower the flow rate with the y flow control valve until popping out no longer occurs.
3. Reconfirm the speed.

(Note 1) As comparing b, c and d, Circuit d is the most stable.

(Note 2) When installed vertically, the unit will drop naturally if the meter-in circuit is used. Use the meter-out circuit in this case.

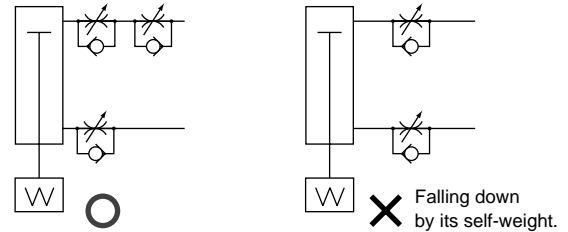

(Note 3) For serial connection of flow control valve, provide a circuit as the following diagram.

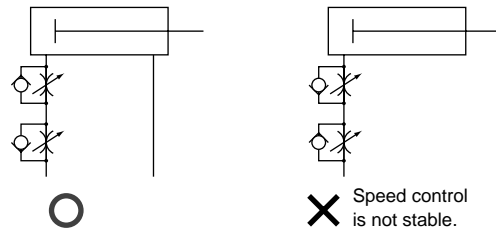

(Cause of popping out phenomenon)

- The meter-out circuit slows the flow so fine speed is attained on the exhaust side. Both sides reach the same pressure immediately after the valve is changed and the thrust of the piston pressurized area difference functions in the PUSH direction, causing popping out.

(Reference of popping out occurrence)

- When piston rod area X air pressure > load resistance, this occurs.

■ Do not apply lateral load to the cylinder.

Install the cylinder to avoid the sliding guide to be twisted.

- The presence of load or resistance variation may result in unstable operations.
- Operation of a guide having a large difference in stationary and moving friction may become unstable.

■ Avoid use in the place subject to vibration.

- The product will be adversely affected by vibration and operation will become unstable.

SCP*2
CMK2
CMA2
SCM
SCG
SCA2
SCS
CKV2
CA/OV2
SSD
CAT
MDC2
MVC
SMD2
MSD*
FC*
STK
ULK*
JSK/M2
JSG
JSC3
USSD
USC
JSB3
LMB
STG
STS/L
LCS
LCG
LCM
LCT
LCY
STR2
UCA2
HCM
HCA
SRL2
SRG
SRM
SRT
MRL2
MRG2
SM-25
CAC3
UCAC
RCC2
MFC
SHC
GLC
Ending

Medium bore size cylinder
Standard type

2. Coolant proof type CMK2-G2/G3

CAUTION

- Do not apply the deviated load onto the piston rod. It could shorten scraper and bearing life.
- If coolant or water do not get on the piston rod, select the G or G1 Series.
If coolant or water do not get on the G2 or G3 series, piston rod lubrication could be spent and shorten life.
- Install a flow control valve on the cylinder.
 - Install a flow control valve on the cylinder.
Use within the applicable piston speed range for each cylinder.

3. Position locking type CMK2-Q

WARNING

- If pressure is supplied to port (A) in the locked state with neither port pressurized, locks may not be releasable or may be released suddenly, causing the piston rod to pop out, which is extremely dangerous. When release locking mechanism, always supply pressure to Port (B) and confirm the state if no load is applied to the locking mechanism before release lock.

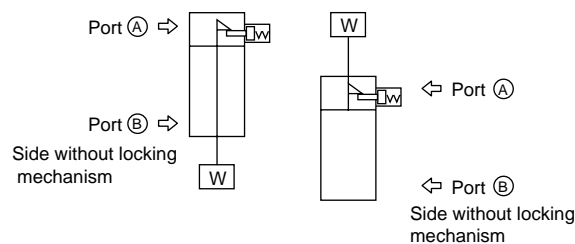

- If a quick exhaust valve is installed to increase the drop speed, this may result in a failure to unlock because the speed of cylinder piston is faster than the speed of lock pin release. Do not use a quick exhaust valve in the circuit that a position locking type cylinder is installed.

- Do not use 3-position solenoid valve.

Do not use this together with 3-position solenoid valve (especially with closed center metal seal type). This kind of use closes the pressure at the locking mechanism side, and is unable to lock the position. Even once locked, air leakage from a solenoid valve would enter to a cylinder and this may release locking.

CAUTION

- Cylinder load factor must be 50% or less.
 - If the load factor is high, the lock may not be released or the lock could be damaged.
- Do not operate cylinders synchronously.
Do not use more than two cylinders with position locking mechanism simultaneously. One of cylinder may results in failures of unlocking.

Installation & Adjustment

1. Common

CAUTION

- Do not rotate the cover.
 - When installing a cylinder or a joint onto the port, turning the cover may cause failures at connecting section of the cover.

2. Single acting CMK2-S/SR

CAUTION

- Do not leave single acting type at pressurized state.
After leaving under elevated pressure, the piston rod may not return by the spring force when pressure is released.

3. Stroke adjustable type CMK2-P/R

CAUTION

- Securely lock the bolt for stroke adjustment with the lock nut.
- When adjusting stroke, follow the procedures from (1) to (5).
Failure to observe this adjusting method may lead to breakage of washer after one or two adjustment.

[Procedure of stroke adjustment]

- At first, loosen the lock nut as state of Fig.1 .

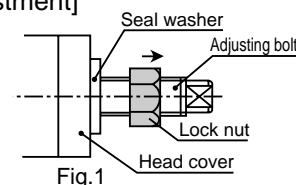

- Then, apart the seal washer from the head cover by hand to be as state of Fig. 2.

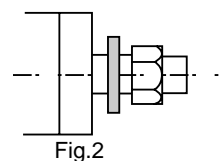

- Holding this state, turn the adjustment bolt with the nut and the seal washer to adjust stroke. During this operation, pay attention to avoid biting the seal washer rubber at the thread section.

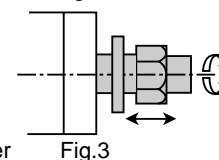

- Shift the seal washer toward the head cover by a hand after stroke adjustment as Fig. 4.

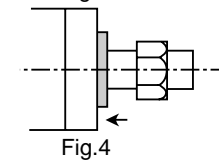

- Then, tighten the lock-nut securely as Fig.5. During this operation, pay attention to avoid biting the seal washer rubber at the thread section.

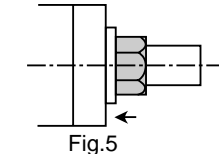

SCP*2
CMK2
 CMA2
 SCM
 SCG
 SCA2
 SCS
 CKV2
 CA/OV2
 SSD
 CAT
 MDC2
 MVC
 SMD2
 MSD*
 FC*
 STK
 ULK*
 JSK/M2
 JSG
 JSC3
 USSD
 USC
 JSB3
 LMB
 STG
 STS/L
 LCS
 LCG
 LCM
 LCT
 LCY
 STR2
 UCA2
 HCM
 HCA
 SRL2
 SRG
 SRM
 SRT
 MRL2
 MRG2
 SM-25
 CAC3
 UCAC
 RCC2
 MFC
 SHC
 GLC
 Ending

- Tighten lock-nut with the tightening torque in the table 1 securely after stroke adjustment. Failure to observe this may lead to loose of lock-nut during operation and result in external leakage.

Table 1 Tightening torque Unit: N·m

Bore size	CMK2-P (extended)	CMK2-R (retracted)
φ20	15.8	11.9
φ25	33.4	37
φ32	33.4	37
φ40	55.8	37

- Stud bolt sealing cannot be used with high frequent operation because a seal washer is used.

- If the stroke adjusted, cushioning would not work.

4. Heat resistance type CMK2-T

⚠ CAUTION

- Magnet is not integrated.

5. Rubber-air cushioned CMK2-*C

⚠ CAUTION

- This structure cannot hold the stroke end position when the air supply stops. Perform switch setting at a pressurized state.

6. Position locking type CMK2-Q

⚠ CAUTION

- This locking mechanism works only at the stroke end. If an external locking mechanism like a stopper is applied before the stroke end, this may result in a failure of locking and load to drop of the piston rod. When a load is applied to this cylinder, check that the locking mechanism works correctly before installation.

- Supply pressure higher than minimum working pressure of each model to the port with locking mechanism.

- A long and narrow pipe installed on the locking mechanism side or a flow control valve apart from a cylinder port may reduce an exhaust speed. This may result in a long time until locking mechanism works. A clogged silencer installed on the exhaust port of solenoid valve may pose the same problem.

7. Fine speed type CMK2-F

⚠ CAUTION

- Adjust alignment on a cylinder not to apply lateral load. Install sliding guide without twist and biting.
- The presence of load or resistance variation may result in unstable operations.
- Large differential between static friction and dynamic friction of guide results in unstable operation.

8. Non-rotating type CMK2-M

⚠ CAUTION

- Avoid applications such as a rotation torque applied to piston rod. Failure to observe this would cause deforming of rotating prevention bush and lead to remarkably shortening service life.
- Use this cylinder always in the state that the load is applied to an axial direction of piston rod.
- When fixing a work piece on the end of piston rod, retract the piston rod until the stroke end, use a spanner putting on the section across flat of piston rod which projects from the cylinder tube. When tightening, do not apply a tightening torque to the cylinder body.

During Use & Maintenance

1. Common (T type with switch)

⚠ CAUTION

- Moving the switch position in the stroke direction
 - The 1-color indicator switch can be finely adjusted at ± 3 mm from the default installation position. If the adjustment range exceeds ±3 mm, or when the 2-color indicator switch is adjusted, move the band position.

- Loosen the switch fixing screw, move the switch along the rail, and tighten at the required position. When using the T2, T3, T0 or T5 switch, use a flat-tip screwdriver with a 5 to 6 mm grip, 2.4 mm or smaller tip width, and 0.3 mm or thinner (clock screwdriver, precision screwdriver, etc.), and tighten with a tightening torque of 0.1 to 0.2 N·m. When using T1, T*C, T2J, T2Y, T3Y, T2YF, T3YF, T2YM, T3YM, or T8, tighten with a tightening torque of 0.5 to 0.7 N·m.

SCP*2
CMK2
CMA2
SCM
SCG
SCA2
SCS
CKV2
CA/OV2
SSD
CAT
MDC2
MVC
SMD2
MSD*
FC*
STK
ULK*
JSK/M2
JSG
JSC3
USSD
USC
JSB3
LMB
STG
STS/L
LCS
LCG
LCM
LCT
LCY
STR2
UCA2
HCM
HCA
SRL2
SRG
SRM
SRT
MRL2
MRG2
SM-25
CAC3
UCAC
RCC2
MFC
SHC
GLC
Ending

Medium bore size cylinder
Standard type

- The switch bracket rail has a mark 4 mm from the rail end. Use this as a guide to the mounting position when replacing the switch. Switch rail markings are set to the default switch maximum sensitivity. Maximum sensitivity changes when the switch type is changed or when the switch bracket is moved. Adjust the position accordingly.

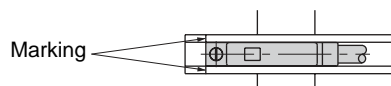

- **Shifting the switch position in the circumference direction**
 - Loosen the band fixing screw, shift the switch rail in the circumference direction, then tighten at the specified position. Tightening torque is 0.6 to 0.8 N·m.

- **Shifting the band position**
 - Loosen the band fixing screw, shift the switch rail and band along cylinder tubing, then tighten at the specified position. Tightening torque is 0.6 to 0.8 N·m.

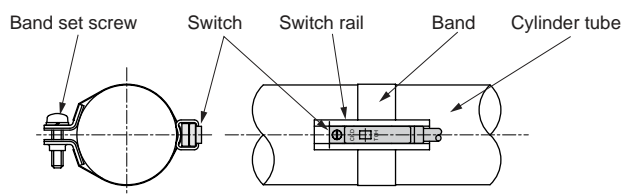

2. Position locking type CMK2-Q

⚠ WARNING

- For safety purposes, prevent the load from dropping by its own weight during maintenance.
- When stopping with an external shock absorber, etc., adjust in the same manner so that no bouncing occurs. If the piston bounces at the stroke end, the sleeve and stopper position could impact and damage the lock mechanism. Once or twice a year, check that the holding section is not damaged by this symptom.

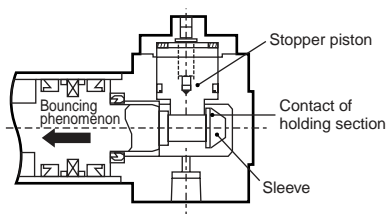

⚠ CAUTION

- This cylinder cannot be disassembled, so do not apply excessive force to the end cover or tube. If back pressure is applied to the locking mechanism, the lock may be released. Use the solenoid valve as a discrete unit, or use an independently exhausted manifold.

- After operating locking mechanism manually, always return the manual override to the original position. Do not operate the manual override except adjustment. It is dangerous.

- Release the lock when installing or adjusting the cylinder. The lock could be damaged if the cylinder is installed while the lock is applied.

- Use the flow control valve by the meter-out control. Locks may not be released during meter-in control.

- On the side of locking mechanism, the piston rod must reach the stroke limit. If the cylinder's piston does not reach the stroke end, the lock may not be applied or may not be released.

- **Release method of non-locking manual override**
Screw a hexagon socket head cap screw into a stopper piston, and pull the bolt 4 mm with more than 20N. Movement of stopper piston results in unlocking. (For no load horizontal installation or the opposite side port pressurization) releasing a hand leads to return of stopper piston by integrated spring force, and inserting this into piston rod groove results in locking of piston.

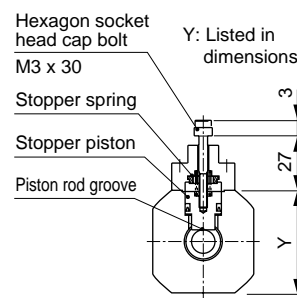

- **Release method of locking manual override**
Turning the round nut counterclockwise results in stopper piston movement and release of lock. Turning the round nut clockwise to set at the lock position leads to return of the stopper pin. Inserting this pin into the piston rod groove results in locking.

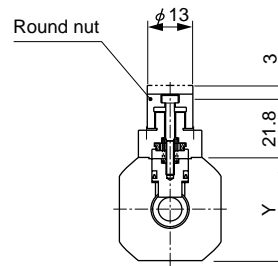

3. Coolant proof type

⚠ CAUTION

- The G3 Series uses fluorine-based grease. If personnel light cigarettes with fluorine-based grease on their hands, toxic gases that could cause bodily harm would be generated.

SCP*2
CMK2
 CMA2
 SCM
 SCG
 SCA2
 SCS
 CKV2
 CA/OV2
 SSD
 CAT
 MDC2
 MVC
 SMD2
 MSD*
 FC*
 STK
 ULK*
 JSK/M2
 JSG
 JSC3
 USSD
 USC
 JSB3
 LMB
 STG
 STS/L
 LCS
 LCG
 LCM
 LCT
 LCY
 STR2
 UCA2
 HCM
 HCA
 SRL2
 SRG
 SRM
 SRT
 MRL2
 MRG2
 SM-25
 CAC3
 UCAC
 RCC2
 MFC
 SHC
 GLC
 Ending

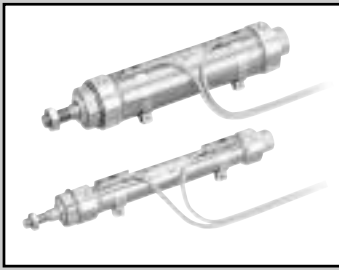

Medium bore size cylinder
 Double acting single rod type

CMK2 Series

● Bore size: ϕ 20, ϕ 25, ϕ 32, ϕ 40

JIS symbol ● Double acting cylinder single rod type



Specifications

Descriptions		CMK2			
Bore size	mm	ϕ 20	ϕ 25	ϕ 32	ϕ 40
Actuation		Double acting			
Working fluid		Compressed air			
Max. working pressure	MPa	1.0			
Min. working pressure	MPa	0.1			
Withstanding pressure	MPa	1.6			
Ambient temperature	°C	-10 to 60 (no freezing)			
Port size		Rc1/8			
Stroke tolerance	mm	$^{+2.0}_0$ (up to 200), $^{+2.4}_0$ (over 200)			
Working piston speed	mm/s	50 to 500			
Cushion		Rubber cushion			
Lubrication		Not required (when lubricating, use turbine oil Class 1 ISO VG32.)			
Allowable energy absorption	J	0.166	0.308	0.424	0.639

Stroke length

Bore size (mm)	Standard stroke length (mm)	Max. stroke length (mm)	Min. stroke length (mm)
ϕ 20	25, 50, 75, 100, 150, 200, 250, 300	750	5
ϕ 25			
ϕ 32			
ϕ 40			

Note 1: Custom stroke length is available per 1 mm increment.
 Note 2: For single foot type (LS type), maximum stroke length is 50 mm.
 Note 3: For bellows "J" type, stroke length should be longer than 25 mm.
 Consult with CKD when stroke length is shorter than 25 mm.

Min. stroke length of type with switch

(Unit: mm)

Switch quantity	1					2				3			
	Proximity		Reed			Proximity		Reed		Proximity		Reed	
	T2, T3	T1, T*Y*	T0, T5	T8	T2, T3	T1, T*Y*	T0, T5	T8	T2, T3	T1, T*Y*	T0, T5	T8	
Bore size (mm)													
ϕ 20	10					25	35	25	35	50	55	50	55
ϕ 25	10					25	35	25	35	50	55	50	55
ϕ 32	10					25	35	25	35	50	55	50	55
ϕ 40	10					25	35	25	35	50	55	50	55

Note 1: Up to three switches can be mounted.

Switch specifications

- 1 color/2 color indicator

* The T0/T5 switch can be used with 220 VAC. Contact CKD for working conditions.

Descriptions	Proximity 2-wire			Proximity 3-wire			Reed 2-wire							
	T1H/T1V	T2H/T2V/ T2JH/T2JV	T2YH/ T2YV	T3H/ T3V	T3PH/T3PV (Custom order)	T3YH/ T3YV	TOH/TOV		T5H/T5V		T8H/T8V			
Applications	Programmable controller Relay, small solenoid valve	Programmable controller dedicated		Programmable controller, relay			Programmable controller, relay		Programmable controller, relay, IC circuit (w/o light), serial connection		Programmable controller, relay			
Output method	-			NPN output	PNP output	NPN output	-							
Power voltage	-			10 to 28 VDC			-							
Load voltage	85 to 265 VAC	10 to 30 VDC		30 VDC or less			12/24 VDC	110 VAC	5/12/24 VDC	110 VAC	12/24 VDC	110 VAC	220 VAC	
Load current	5 to 100 mA	5 to 20 mA (Note 1)		100 mA or less			50 mA or less	5 to 50 mA	7 to 20 mA	50 mA or less	20 mA or less	5 to 50 mA	7 to 20 mA	7 to 10 mA
Light	LED (ON lighting)	LED (ON lighting)	Red/green LED (ON lighting)	LED (ON lighting)	Green LED (ON lighting)	Red/Green LED (ON lighting)	LED (ON lighting)		Without indicator light		LED (ON lighting)			
Leakage current	1 mA or less with 100 VAC 2 mA or less with 200 VAC		1 mA or less		10 μA or less			0 mA						

- With preventive maintenance output

Descriptions	Proximity 3-wire		Proximity 4-wire		Proximity 3-wire		Proximity 4-wire			
	T2YFH/V		T3YFH/V		T2YMH/V		T3YMH/V			
Applications	Programmable controller dedicated		Programmable controller, relay		Programmable controller dedicated		Programmable controller, relay			
Output method	NPN output									
Light	Red/Green LED (ON lighting)									
	Installation position adjustment		-						Yellow LED (ON lighting)	
Regular Output section	Preventive maintenance output		-						Yellow LED (ON lighting)	
	Power voltage		-		10 to 28 VDC		-		10 to 28 VDC	
	Load voltage		10 to 30 VDC		30 VDC or less		10 to 30 VDC		30 VDC or less	
	Load current		5 to 20 mA		50 mA or less		5 to 20 mA		50 mA or less	
Preventive maintenance Output section	Leakage current		1 mA or less		10 μA or less		1.2 mA or less		10 μA or less	
	Load voltage		30 VDC or less							
	Load current		20 mA or less		50 mA or less		5 to 20 mA or less		50 mA or less	
	Leakage current		10 μA or less							

Note 1: Refer to Ending 1 for other switches.

Note 2: The above maximum load current of 20 mA applies at 25 °C. If the switch's working ambient temperature exceeds 25 °C, the load current will be lower than 20 mA. (5 to 10 mA when 60 °C)

Bellows max. working temperature

Symbol	Bellows material	Max. ambient	Instantaneous maximum
J	Polyolefin elastomer	100 °C	200 °C
L	Silicone rubber glass cloth	250 °C	400 °C

Instantaneous maximum temperature is the temperature when spark and spatter etc. instantaneously contacts to bellows.

Cylinder weight

(Unit: kg)

Descriptions/ mounting style	Product weight when stroke length (S) = 0 mm								Switch weight	Switch rail + band weight	Additional weight per S = 10 mm
	Basic type (00)	Axial foot type (LB)	Axial foot type (LS)	Flange type (FA/FB)	Eye bracket type (CA)	Clevis type (CC)	Clevis bracket type (CB)	Trunnion type (TA/TB)	Grommet		
φ 20	0.17	0.32	0.25	0.23	0.32	0.18	0.32	0.22	0.018	0.005	0.01
φ 25	0.26	0.52	0.39	0.41	0.50	0.26	0.50	0.36	0.018	0.005	0.01
φ 32	0.30	0.56	0.43	0.45	0.54	0.30	0.54	0.40	0.018	0.009	0.02
φ 40	0.48	0.74	0.61	0.63	0.72	0.50	0.72	0.64	0.018	0.009	0.02

(E.g.) Product weight of CMK2-FA-32-50-T0H-D

When S = 0 mm, product weight is 0.45 kg

Additional weight at S = 50 mm is additional weight at S = 10 mm $0.02 \times \frac{\text{Product stroke length (50)}}{10} = 0.10$ kg

Weight of two switches is 0.036 kg

Weight of switch rail and two bands is 0.018 kg

Product weight is 0.45 kg + 0.1 kg + 0.036 kg + 0.018 kg = 0.604 kg

SCP*2
CMK2
CMA2
SCM
SCG
SCA2
SCS
CKV2
CA/OV2
SSD
CAT
MDC2
MVC
SMD2
MSD*
FC*
STK
ULK*
JSK/M2
JSG
JSC3
USSD
USC
JSB3
LMB
STG
STS/L
LCS
LCG
LCM
LCT
LCY
STR2
UCA2
HCM
HCA
SRL2
SRG
SRM
SRT
MRL2
MRG2
SM-25
CAC3
UCAC
RCC2
MFC
SHC
GLC

Ending

Medium bore size cylinder
Standard type

How to order

Without switch

CMK2 - 00 - 20 - 100 - Y

With switch

CMK2 - 00 - 20 - 100 - T0H - R - V - Y

A Mounting style
Note 1

B Bore size

C Port thread type

D Stroke length
Note 1

E Switch model no.

F Switch quantity
Note 9

G Option
Note 4, Note 5, Note 6

H Accessory
Note 7

Note on model no. selection

Note 1: For single foot type (LS type), maximum stroke length is 50 mm.

Note 2: Refer to page 90 for min. stroke length with switch.

Note 3: Applicable tube O.D. of F; push-in joint (straight) and FE; push-in joint (elbow) is ϕ 6.

Note 4: For bellows "J" type, stroke length should be longer than 25 mm. When stroke length is shorter than 25 mm, consult with CKD.

Note 5: Instantaneous maximum temperature is the temperature when spark and spatter etc. instantaneously contacts to bellows.

Note 6: "I" and "Y" can not be selected at the same time.

Note 7: Refer to Ending 89 for the custom order specifications of rod end form.

Note 8: Refer to page 84 for variation and combinations of options.

Note 9: Up to three switches can be mounted. If more than four switches are required, switch mounting brackets for the extra switches must be prepared separately.

<Example of model number>

CMK2-00-20-100-T0H-R-VY

Model: Medium bore size cylinder, double acting, standard type

- A** Mounting style : Basic type
- B** Bore size : ϕ 20 mm
- C** Port thread type : Rc thread
- D** Stroke length : 100 mm
- E** Switch model no. : Reed T0H switch and lead wire 1 m
- F** Switch quantity : One on rod end
- G** Option : Boss cut off
- H** Accessory : Rod clevis

Symbol	Descriptions
A Mounting style	
00	Basic type
LB	Axial foot type (both sides)
LS	Axial foot type (single)
FA	Rod side flange type
FB	Head side flange type
CA	Eye bracket type
CC	Fixed eye
CC1	Eye and bush press fitted type
CB	Clevis bracket type (pin and washer split pin attached)
TA	Rod side trunnion type
TB	Head side trunnion type

B Bore size (mm)	
20	ϕ 20
25	ϕ 25
32	ϕ 32
40	ϕ 40

C Port thread type	
Blank	Rc thread
NN	NPT thread (custom order)
GN	G thread (custom order)

D Stroke length (mm)		
Bore size	Stroke length Note 2	Custom stroke length
ϕ 20	5 to 750	By 1 mm increment
ϕ 25	5 to 750	
ϕ 32	5 to 750	
ϕ 40	5 to 750	

E Switch model no.				
Lead wire Straight type	Lead wire L type	Contact	Indicator	Lead wire
T0H*	T0V*	Reed	1 color	2-wire
T5H*	T5V*		Without indicator light	
T8H*	T8V*		1 color	
T1H*	T1V*	Proximity	1 color	2-wire
T2H*	T2V*			3-wire
T3H*	T3V*		1 color (custom order)	3-wire
T3PH*	T3PV*			2-wire
T2YH*	T2YV*		2 color	3-wire
T3YH*	T3YV*			3-wire
T2YFH*	T2YFV*		2 color (w/o light for preventive maintenance output)	3-wire
T3YFH*	T3YFV*			4 wire
T2YMH*	T2YMV*		2 color (w/ light for preventive maintenance output (1 color))	3-wire
T3YMH*	T3YMV*			4 wire
T2JH*	T2JV*	Off-delay type	2-wire	

* Lead wire length	
Blank	1 m (standard)
3	3 m (option)
5	5 m (option)

F Switch quantity	
R	One on rod end
H	One on head end
D	Two
T	Three

G Option			
		Max. ambient	Max. instantaneous
J	Bellows	100 °C	200 °C
L	Bellows	250 °C	400 °C
F	Push-in joint (straight)		
FE	Push-in joint (elbow)		
M	Piston rod material (stainless steel)		
V	Boss cut off		
P6	Copper and PTFE free		

H Accessory	
I	Rod eye
Y	Rod clevis (pin and washer split pin are attached.)
B2	Clevis bracket (pin and snap ring are attached.)

How to order switch

- Switch body + mounting bracket

CMK2 - **T0H** - **20**

Switch model no. (item ⑤ previous page) Bore size (item ⑤ previous page)

- Only switch body

SW - **T0H**

Switch model no. (item ⑤ previous page)

- Mounting bracket

CMK2 - **T** - **20**

Bracket Bore size (item ⑤ previous page)

How to order mounting bracket

Bore size (mm)	φ 20	φ 25	φ 32	φ 40
Axial foot type (LB/LS)	M1-LB-20	M1-LB-30	M1-LB-30	M1-LB-30
Flange (FA/FB)	M1-FA-20	M1-FA-30	M1-FA-30	M1-FA-30
Trunnion (TA/TB)	M1-TA-20	M1-TA-30	M1-TA-30	M1-TA-40
Eye bracket type (CA)	M1-CA-20	M1-CA-30	M1-CA-30	M1-CA-30
Clevis bracket type (CB)	M1-CB-20	M1-CB-30	M1-CB-30	M1-CB-30

Note 1: Mounting nut/toothed washer are attached to each mounting bracket.

Note 2: Two sets of "M1-LB-*1" in the above table are required for the axial direction foot (double-sided).

SCP*2
CMK2
CMA2
SCM
SCG
SCA2
SCS
CKV2
CA/OV2
SSD
CAT
MDC2
MVC
SMD2
MSD*
FC*
STK
ULK*
JSK/M2
JSG
JSC3
USSD
USC
JSB3
LMB
STG
STS/L
LCS
LCG
LCM
LCT
LCY
STR2
UCA2
HCM
HCA
SRL2
SRG
SRM
SRT
MRL2
MRG2
SM-25
CAC3
UCAC
RCC2
MFC
SHC
GLC
Ending

Medium bore size cylinder
Standard type

Internal structure and parts list

- SCP*2
- CMK2**
- CMA2
- SCM
- SCG
- SCA2
- SCS
- CKV2
- CA/OV2
- SSD
- CAT
- MDC2
- MVC
- SMD2
- MSD*
- FC*
- STK
- ULK*
- JSK/M2
- JSG
- JSC3
- USSD
- USC
- JSB3
- LMB
- STG
- STS/L
- LCS
- LCG
- LCM
- LCT
- LCY
- STR2
- UCA2
- HCM
- HCA
- SRL2
- SRG
- SRM
- SRT
- MRL2
- MRG2
- SM-25
- CAC3
- UCAC
- RCC2
- MFC
- SHC
- GLC
- Ending

● CMK2

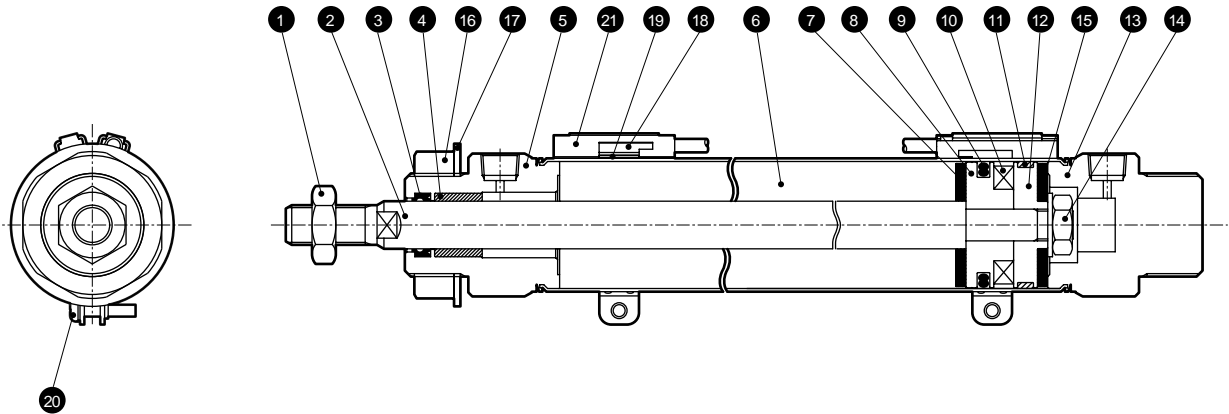

● Note: This caulking type cannot be disassembled.

No.	Parts name	Material	Remarks	No.	Parts name	Material	Remarks
1	Rod nut	Steel	Zinc chromate	11	Wear ring	Polyacetal resin	
2	Piston rod	$\phi 20, \phi 25$: Stainless steel $\phi 32, \phi 40$: Carbon steel	Industrial chrome plating	12	Piston B	Aluminum alloy	
3	Rod packing seal	Nitrile rubber		13	Head cover	Aluminum alloy	
4	Bush	$\phi 20$: Dry bearing $\phi 25, \phi 32, \phi 40$: Copper	Note 1	14	Hexagon nut	Steel	Zinc chromate
5	Rod cover	Aluminum alloy		15	Spacer	Steel	Zinc chromate
6	Cylinder tube	Stainless steel		16	Nut	Steel	Zinc chromate
7	Cushion rubber	Urethane rubber		17	The toothed washer	Steel	Zinc chromate
8	Piston A	Aluminum alloy		With switch			
9	Piston packing seal	Nitrile rubber		18	Switch body		
10	Magnet	Plastic		19	Band	Stainless steel	
				20	Pan head machine screw	Stainless steel	
				21	Switch rail	Stainless steel	

Note 1: For copper and PTFE free specifications, oil impregnated resin bearing is used.

Mounting bracket material

Mounting style	Material
LB/LS	Steel
FA/FB	Steel
TA/TB	Steel
CA	Steel
CB	Steel

● Note: Mounting bracket is attached to the product when shipped.

Dimensions



● Basic type (00)

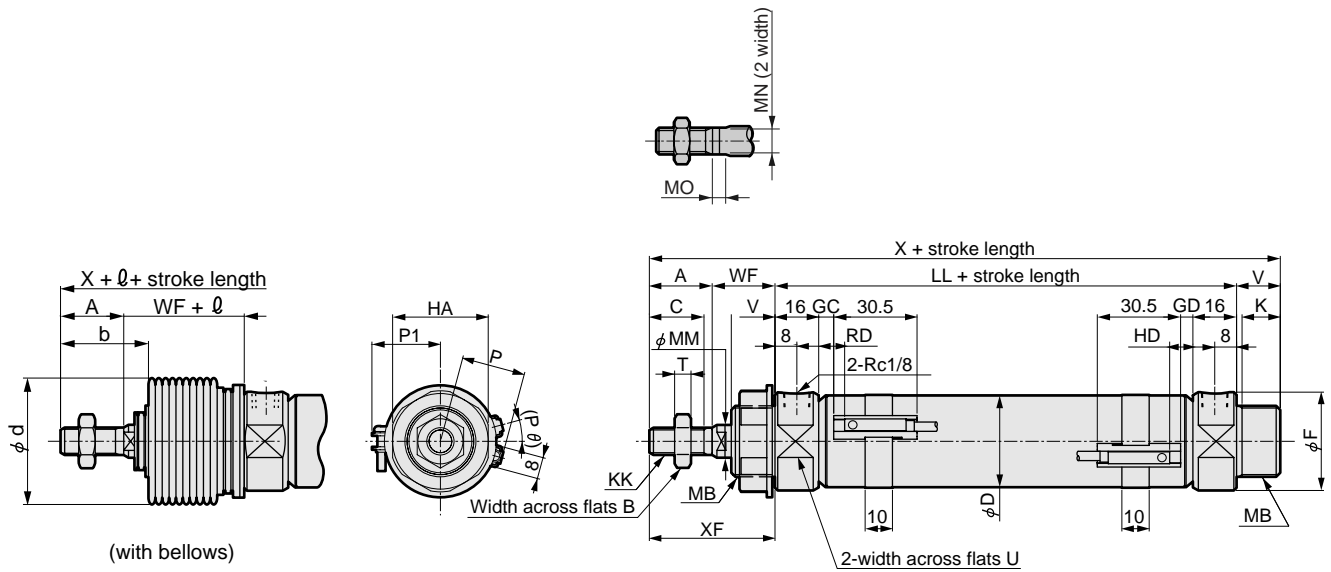

RD: Rod side max. sensitive position
 HD: Head side max. sensitive position

Symbol	Basic dimensions of basic type (00)																			
Bore size (mm)	A	B	C	D	F	HA	K	KK	LL	MB	MM	MN	MO	T	U	V	WF	X	XF	
φ 20	20	13	18	21.4	28	26	12	M8 x 1.0	66	M18 x 1.5	10	8	5	5	24	14	24	124	44	
φ 25	23	17	20	26.4	32	35	14	M10 x 1.25	69	M26 x 1.5	12	10	5	6	30	16	23	131	46	
φ 32	23	17	20	33.6	36	35	14	M10 x 1.25	69	M26 x 1.5	12	10	5	6	34	16	23	131	46	
φ 40	25	19	22	41.6	45	35	14	M12 x 1.5	73	M26 x 1.5	14	12	6	7	43	16	23	137	48	
Symbol	With switch							With bellows												
Bore size (mm)	GC	GD	RD	HD	P	P1	(Pθ)°	b	d	ℓ										
φ 20	4.0	3.0	8.0	7.0	17.3	19.5	22	30	30	(stroke length/3) + 6										
φ 25	5.5	4.5	9.5	8.5	19.8	22.0	18	32	46	(stroke length/3.25) + 7										
φ 32	5.5	4.5	9.5	8.5	24.3	25.5	15	32	46	(stroke length/3.25) + 7										
φ 40	7.0	6.5	11.5	10.5	28.3	29.5	12	34	46	(stroke length/3.25) + 7										

Note 1: For ℓ dimensions, round up decimal point or less.

Note 2: Refer to page 188 for the HD, RD, and projecting dimensions of the T1* and T8* switches and 2-color indicator switch with preventive maintenance output.

Note 3: Refer to page 190 for dimensions of accessories.

- SCP*2
- CMK2**
- CMA2
- SCM
- SCG
- SCA2
- SCS
- CKV2
- CA/OV2
- SSD
- CAT
- MDC2
- MVC
- SMD2
- MSD*
- FC*
- STK
- ULK*
- JSK/M2
- JSG
- JSC3
- USSD
- USC
- JSB3
- LMB
- STG
- STS/L
- LCS
- LCG
- LCM
- LCT
- LCY
- STR2
- UCA2
- HCM
- HCA
- SRL2
- SRG
- SRM
- SRT
- MRL2
- MRG2
- SM-25
- CAC3
- UCAC
- RCC2
- MFC
- SHC
- GLC
- Ending

Medium bore size cylinder
Standard type

Dimensions



● Axial foot type (LB)

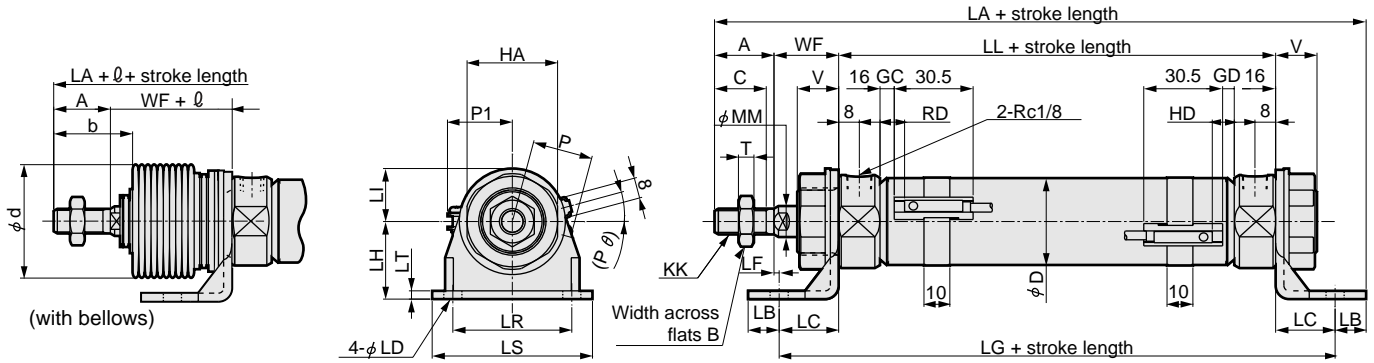

Note 1: For ℓ dimensions, round up decimal point or less.

Note 2: Refer to page 188 for the HD, RD, and projecting dimensions of the T1* and T8* switches and 2-color indicator switch with preventive maintenance output.

Note 3: Refer to page 190 for dimensions of accessories.

Symbol	Axial foot type (LB) basic dimensions											Installation dimensions					
	A	B	C	D	HA	KK	LL	MM	T	V	WF	LA	LB	LC	LD	LF	LG
φ 20	20	13	18	21.4	26	M8 x 1.0	66	10	5	14	24	138	10	18	6	6	102
φ 25	23	17	20	26.4	35	M10 x 1.25	69	12	6	16	23	150	12	23	7	0	115
φ 32	23	17	20	33.6	35	M10 x 1.25	69	12	6	16	23	150	12	23	7	0	115
φ 40	25	19	22	41.6	35	M12 x 1.5	73	14	7	16	23	156	12	23	7	0	119
Symbol	With switch											With bellows					
	LH	LI	LR	LS	LT	GC	GD	RD	HD	P	P1	(P θ)°	b	d	ℓ		
φ 20	25	15	30	44	3.2	4.0	3.0	8.0	7.0	17.3	19.5	22	30	30	(stroke length/3) + 6		
φ 25	30	20	46	62	3.2	5.5	4.5	9.5	8.5	19.8	22.0	18	32	46	(stroke length/3.25) + 7		
φ 32	30	20	46	62	3.2	5.5	4.5	9.5	8.5	24.3	25.5	15	32	46	(stroke length/3.25) + 7		
φ 40	30	20	46	62	3.2	7.0	6.5	11.5	10.5	28.3	29.5	12	34	46	(stroke length/3.25) + 7		

● Single axial foot type (LS)

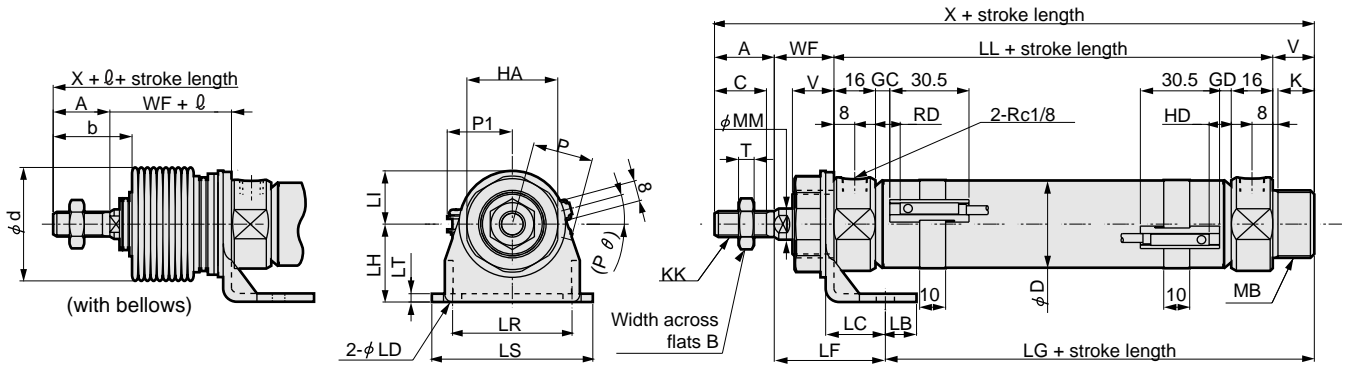

Note 1: For ℓ dimensions, round up decimal point or less.

Note 2: Refer to page 188 for the HD, RD, and projecting dimensions of the T1* and T8* switches and 2-color indicator switch with preventive maintenance output.

Note 3: Up to 50mm stroke.

Note 4: Refer to page 190 for dimensions of accessories.

Symbol	Single axial foot type (LS) basic dimensions														Installation dimensions			
	A	B	C	D	HA	K	KK	LL	MB	MM	T	V	WF	X	LB	LC	LD	
φ 20	20	13	18	21.4	26	12	M8 x 1.0	66	M18 x 1.5	10	5	14	24	124	10	18	6	
φ 25	23	17	20	26.4	35	14	M10 x 1.25	69	M26 x 1.5	12	6	16	23	131	12	23	7	
φ 32	23	17	20	33.6	35	14	M10 x 1.25	69	M26 x 1.5	12	6	16	23	131	12	23	7	
φ 40	25	19	22	41.6	35	14	M12 x 1.5	73	M26 x 1.5	14	7	16	23	137	12	23	7	
Symbol	With switch														With bellows			
	LF	LG	LH	LI	LR	LS	LT	GC	GD	RD	HD	P	P1	(P θ)°	b	d	ℓ	
φ 20	38.8	65.2	25	15	30	44	3.2	4.0	3.0	8.0	7.0	17.3	19.5	22	30	30	(stroke length/3) + 6	
φ 25	42.8	65.2	30	20	46	62	3.2	5.5	4.5	9.5	8.5	19.8	22.0	18	32	46	(stroke length/3.25) + 7	
φ 32	42.8	65.2	30	20	46	62	3.2	5.5	4.5	9.5	8.5	24.3	25.5	15	32	46	(stroke length/3.25) + 7	
φ 40	42.8	69.2	30	20	46	62	3.2	7.0	6.5	11.5	10.5	28.3	29.5	12	34	46	(stroke length/3.25) + 7	

Dimensions



● Rod side flange type (FA)

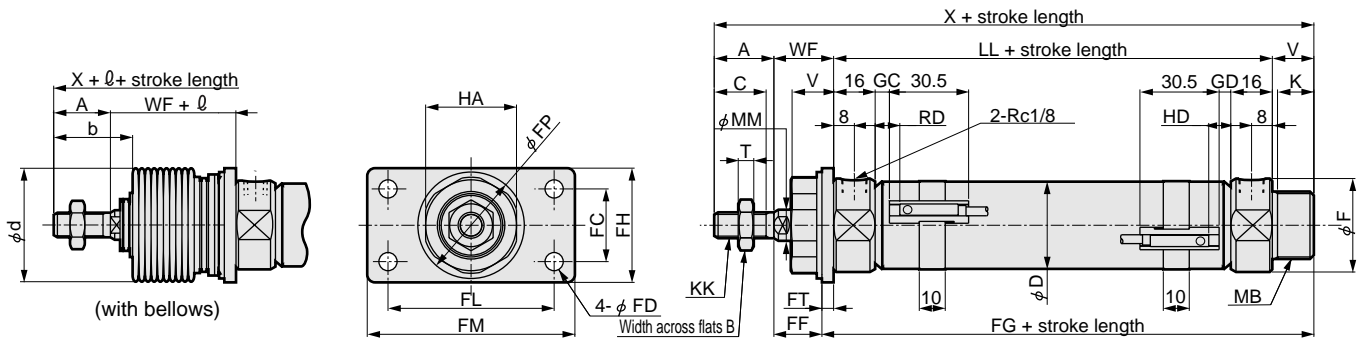

Note 1: For ℓ dimensions, round up decimal point or less.

Note 2: Refer to page 188 for the HD, RD, and projecting dimensions of the T1* and T8* switches and 2-color indicator switch with preventive maintenance output.

Note 3: Refer to page 190 for dimensions of accessories.

Symbol	Rod side flange type (FA) basic dimensions															Installation dimensions	
Bore size (mm)	A	B	C	D	F	HA	K	KK	LL	MB	MM	T	V	WF	X	FC	FD
$\phi 20$	20	13	18	21.4	28	26	12	M8 x 1.0	66	M18 x 1.5	10	5	14	24	124	20	6
$\phi 25$	23	17	20	26.4	32	35	14	M10 x 1.25	69	M26 x 1.5	12	6	16	23	131	28	7
$\phi 32$	23	17	20	33.6	36	35	14	M10 x 1.25	69	M26 x 1.5	12	6	16	23	131	28	7
$\phi 40$	25	19	22	41.6	45	35	14	M12 x 1.5	73	M26 x 1.5	14	7	16	23	137	28	7
Symbol	With switch										With bellows						
Bore size (mm)	FF	FG	FH	FL	FM	FP	FT	GC	GD	RD	HD	b	d	ℓ			
$\phi 20$	20.8	83.2	34	40	54	29	3.2	4.0	3.0	8.0	7.0	30	30	(stroke length/3) + 6			
$\phi 25$	18.5	89.5	44	64	80	41	4.5	5.5	4.5	9.5	8.5	32	46	(stroke length/3.25) + 7			
$\phi 32$	18.5	89.5	44	64	80	41	4.5	5.5	4.5	9.5	8.5	32	46	(stroke length/3.25) + 7			
$\phi 40$	18.5	93.5	44	64	80	41	4.5	7.0	6.5	11.5	10.5	34	46	(stroke length/3.25) + 7			

● Head side flange type (FB)

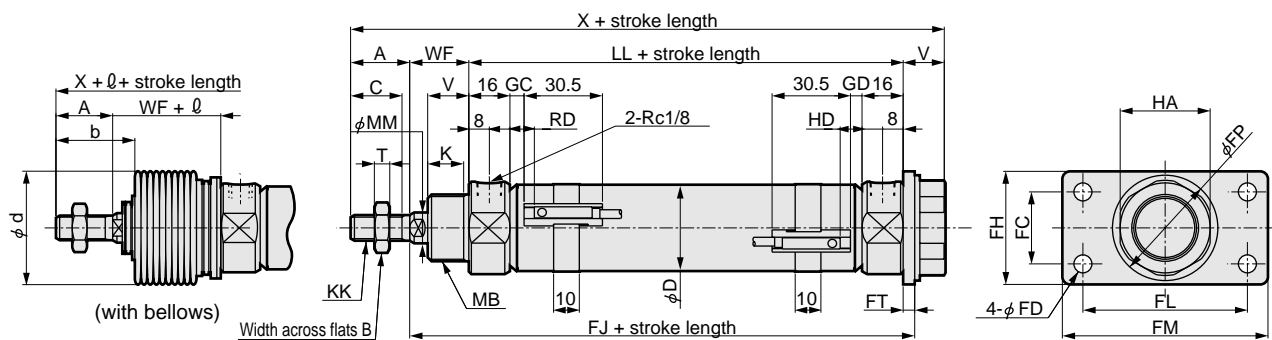

Note 1: For ℓ dimensions, round up decimal point or less.

Note 2: Refer to page 188 for the HD, RD, and projecting dimensions of the T1* and T8* switches and 2-color indicator switch with preventive maintenance output.

Note 3: Refer to page 190 for dimensions of accessories.

Symbol	Head side flange type (FB) basic dimensions															Installation dimensions		
Bore size (mm)	A	B	C	D	HA	K	KK	LL	MB	MM	T	V	WF	X	FC	FD	FH	
$\phi 20$	20	13	18	21.4	26	12	M8 x 1.0	66	M18 x 1.5	10	5	14	24	124	20	6	34	
$\phi 25$	23	17	20	26.4	35	14	M10 x 1.25	69	M26 x 1.5	12	6	16	23	131	28	7	44	
$\phi 32$	23	17	20	33.6	35	14	M10 x 1.25	69	M26 x 1.5	12	6	16	23	131	28	7	44	
$\phi 40$	25	19	22	41.6	35	14	M12 x 1.5	73	M26 x 1.5	14	7	16	23	137	28	7	44	
Symbol	With switch										With bellows							
Bore size (mm)	FJ	FL	FM	FP	FT	GC	GD	RD	HD	b	d	ℓ						
$\phi 20$	93.2	40	54	29	3.2	4.0	3.0	8.0	7.0	30	30	(stroke length/3) + 6						
$\phi 25$	96.5	64	80	41	4.5	5.5	4.5	9.5	8.5	32	46	(stroke length/3.25) + 7						
$\phi 32$	96.5	64	80	41	4.5	5.5	4.5	9.5	8.5	32	46	(stroke length/3.25) + 7						
$\phi 40$	100.5	64	80	41	4.5	7.0	6.5	11.5	10.5	34	46	(stroke length/3.25) + 7						

- SCP*2
- CMK2
- CMA2
- SCM
- SCG
- SCA2
- SCS
- CKV2
- CA/OV2
- SSD
- CAT
- MDC2
- MVC
- SMD2
- MSD*
- FC*
- STK
- ULK*
- JSK/M2
- JSG
- JSC3
- USSD
- USC
- JSB3
- LMB
- STG
- STS/L
- LCS
- LCG
- LCM
- LCT
- LCY
- STR2
- UCA2
- HCM
- HCA
- SRL2
- SRG
- SRM
- SRT
- MRL2
- MRG2
- SM-25
- CAC3
- UCAC
- RCC2
- MFC
- SHC
- GLC
- Ending

Medium bore size cylinder
Standard type

Dimensions



● Eye bracket type (CA)

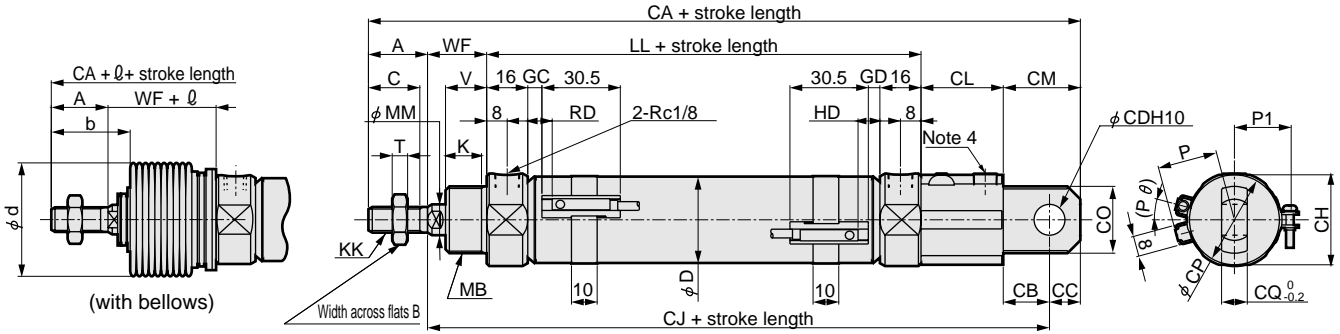

Note 1: For ℓ dimensions, round up decimal point or less.

Note 2: Refer to page 188 for the HD, RD, and projecting dimensions of the T1* and T8* switches and 2-color indicator switch with preventive maintenance output.

Note 3: This is not a piping port.

Note 4: Refer to page 190 for dimensions accessories.

Symbol	Eye bracket type (CA) basic dimensions												Installation dimensions				
Bore size (mm)	A	B	C	D	K	KK	LL	MB	MM	T	V	WF	CA	CB	CC	CD	CH
$\phi 20$	20	13	18	21.4	12	M8 x 1.0	66	M18 x 1.5	10	5	14	24	165	14	10	$10^{+0.058}_0$	26
$\phi 25$	23	17	20	26.4	14	M10 x 1.25	69	M26 x 1.5	12	6	16	23	177	18	12	$12^{+0.070}_0$	35
$\phi 32$	23	17	20	33.6	14	M10 x 1.25	69	M26 x 1.5	12	6	16	23	177	18	12	$12^{+0.070}_0$	35
$\phi 40$	25	19	22	41.6	14	M12 x 1.5	73	M26 x 1.5	14	7	16	23	183	18	12	$12^{+0.070}_0$	35

Symbol	With switch												With bellows			
Bore size (mm)	CJ	CL	CM	CO	CP	CQ	GC	GD	RD	HD	P	P1	(P θ) ^o	b	d	ℓ
$\phi 20$	135	31	24	22	28	8	4.0	3.0	8.0	7.0	17.3	19.5	22	30	30	(stroke length/3) + 6
$\phi 25$	142	32	30	26	37	10	5.5	4.5	9.5	8.5	19.8	22.0	18	32	46	(stroke length/3.25) + 7
$\phi 32$	142	32	30	26	37	10	5.5	4.5	9.5	8.5	24.3	25.5	15	32	46	(stroke length/3.25) + 7
$\phi 40$	146	32	30	26	37	10	7.0	6.5	11.5	10.5	28.3	29.5	12	34	46	(stroke length/3.25) + 7

● Clevis bracket type (CB)

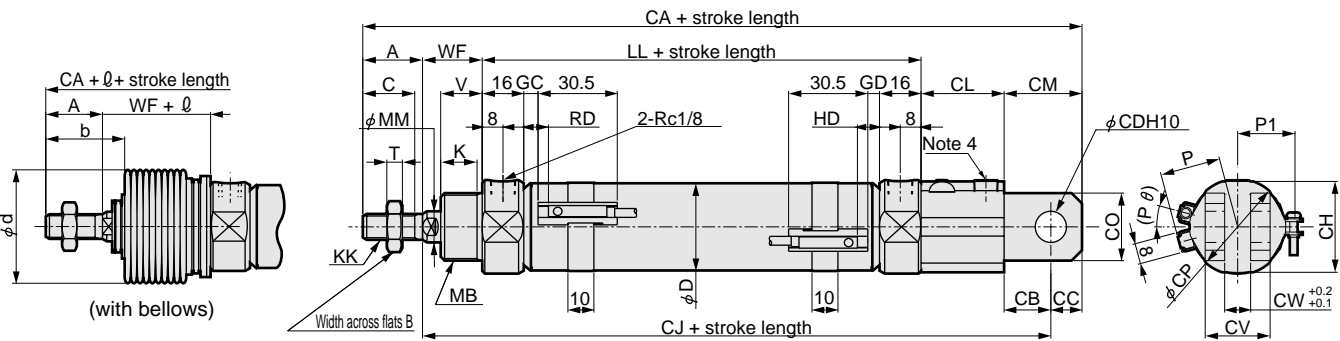

Note 1: For ℓ dimensions, round up decimal point or less.

Note 2: Refer to page 188 for the HD, RD, and projecting dimensions of the T1* and T8* switches and 2-color indicator switch with preventive maintenance output.

Note 3: This is not a piping port.

Note 4: Refer to page 190 for dimensions accessories.

Symbol	Clevis bracket type (CB) basic dimensions.												Installation dimensions				
Bore size (mm)	A	B	C	D	K	KK	LL	MB	MM	T	V	WF	CA	CB	CC	CD	CH
$\phi 20$	20	13	18	21.4	12	M8 x 1.0	66	M18 x 1.5	10	5	14	24	165	14	10	$10^{+0.058}_0$	26
$\phi 25$	23	17	20	26.4	14	M10 x 1.25	69	M26 x 1.5	12	6	16	23	177	18	12	$12^{+0.070}_0$	35
$\phi 32$	23	17	20	33.6	14	M10 x 1.25	69	M26 x 1.5	12	6	16	23	177	18	12	$12^{+0.070}_0$	35
$\phi 40$	25	19	22	41.6	14	M12 x 1.5	73	M26 x 1.5	14	7	16	23	183	18	12	$12^{+0.070}_0$	35

Symbol	With switch												With bellows				
Bore size (mm)	CJ	CL	CM	CO	CP	CV	CW	GC	GD	RD	HD	P	P1	(P θ) ^o	b	d	ℓ
$\phi 20$	135	31	24	22	28	19	8	4.0	3.0	8.0	7.0	17.3	19.5	22	30	30	(stroke length/3) + 6
$\phi 25$	142	32	30	26	37	25	10	5.5	4.5	9.5	8.5	19.8	22.0	18	32	46	(stroke length/3.25) + 7
$\phi 32$	142	32	30	26	37	25	10	5.5	4.5	9.5	8.5	24.3	25.5	15	32	46	(stroke length/3.25) + 7
$\phi 40$	146	32	30	26	37	25	10	7.0	6.5	11.5	10.5	28.3	29.5	12	34	46	(stroke length/3.25) + 7

Dimensions

- Fixed eye (CC)
- Eye bush press fitted type (CC1)

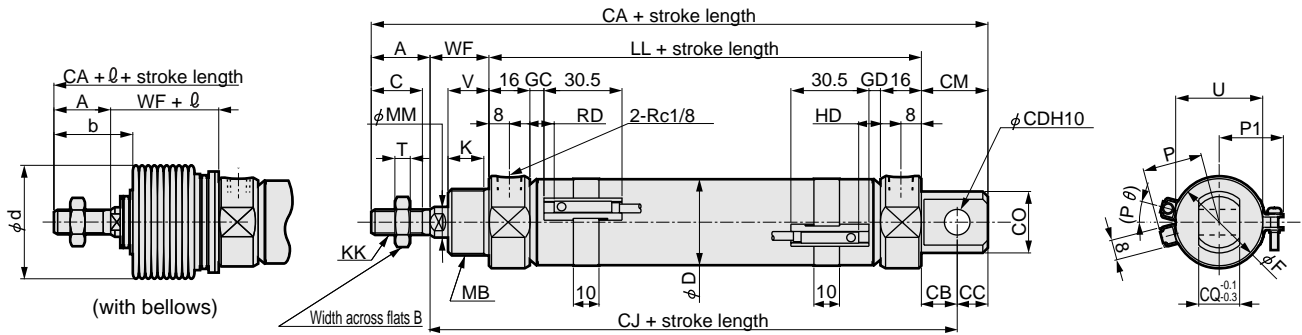

Note 1: For ℓ dimensions, round up decimal point or less.
 Note 2: Refer to page 188 for the HD, RD, and projecting dimensions of the T1* and T8* switches and 2-color indicator switch with preventive maintenance output.
 Note 3: Refer to page 190 for dimensions of accessories.

Symbol	Fixed eye (CC) basic dimensions														Installation dimensions		
	A	B	C	D	F	K	KK	LL	MB	MM	T	U	V	WF	CA	CB	CC
$\phi 20$	20	13	18	21.4	28	12	M8 x 1.0	66	M18 x 1.5	10	5	24	14	24	131	12	9
$\phi 25$	23	17	20	26.4	32	14	M10 x 1.25	69	M26 x 1.5	12	6	30	16	23	136	12	9
$\phi 32$	23	17	20	33.6	36	14	M10 x 1.25	69	M26 x 1.5	12	6	34	16	23	141	14	12
$\phi 40$	25	19	22	41.6	45	14	M12 x 1.5	73	M26 x 1.5	14	7	43	16	23	151	16	14

Symbol	With switch											With bellows				
	CD	CJ	CM	CO	CQ	GC	GD	RD	HD	P	P1	(P θ) ^o	b	d	ℓ	
$\phi 20$	8 ^{+0.058} ₀	102	21	22	16	4.0	3.0	8.0	7.0	17.3	19.5	22	30	30	(stroke length/3) + 6	
$\phi 25$	8 ^{+0.058} ₀	104	21	24	16	5.5	4.5	9.5	8.5	19.8	22.0	18	32	46	(stroke length/3.25) + 7	
$\phi 32$	10 ^{+0.058} ₀	106	26	24	16	5.5	4.5	9.5	8.5	24.3	25.5	15	32	46	(stroke length/3.25) + 7	
$\phi 40$	12 ^{+0.070} ₀	112	30	30	20	7.0	6.5	11.5	10.5	28.3	29.5	12	34	46	(stroke length/3.25) + 7	

- Fixed eye (CC) with bracket (option symbol B2)
- Eye bush press fitted type (CC1) with bracket (option symbol B2)

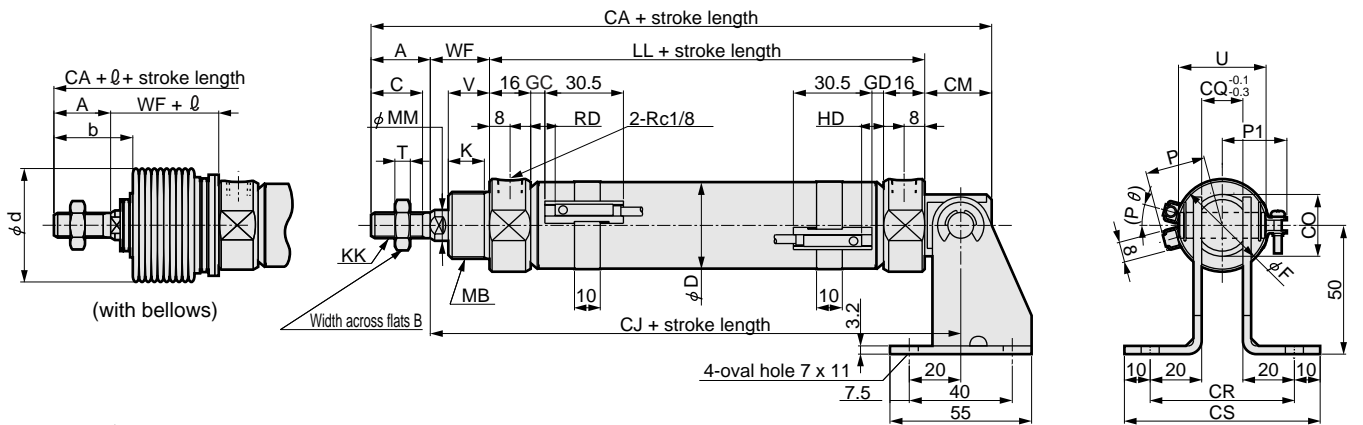

Note 1: For ℓ dimensions, round up decimal point or less.
 Note 2: Refer to page 188 for the HD, RD, and projecting dimensions of the T1* and T8* switches and 2-color indicator switch with preventive maintenance output.
 Note 3: Refer to page 190 for dimensions of accessories.

Symbol	Fixed eye (CC) with bracket (option symbol B2) basic dimensions														Installation dimensions		
	A	B	C	D	F	K	KK	LL	MB	MM	T	U	V	WF	CA	CJ	CM
$\phi 20$	20	13	18	21.4	28	12	M8 x 1.0	66	M18 x 1.5	10	5	24	14	24	131	102	21
$\phi 25$	23	17	20	26.4	32	14	M10 x 1.25	69	M26 x 1.5	12	6	30	16	23	136	104	21
$\phi 32$	23	17	20	33.6	36	14	M10 x 1.25	69	M26 x 1.5	12	6	34	16	23	141	106	26
$\phi 40$	25	19	22	41.6	45	14	M12 x 1.5	73	M26 x 1.5	14	7	43	16	23	151	112	30

Symbol	With switch											With bellows				
	CO	CQ	CR	CS	GC	GD	RD	HD	P	P1	(P θ) ^o	b	d	ℓ		
$\phi 20$	22	16	56	76	4.0	3.0	8.0	7.0	17.3	19.5	22	30	30	(stroke length/3) + 6		
$\phi 25$	24	16	56	76	5.5	4.5	9.5	8.5	19.8	22.0	18	32	46	(stroke length/3.25) + 7		
$\phi 32$	24	16	56	76	5.5	4.5	9.5	8.5	24.3	25.5	15	32	46	(stroke length/3.25) + 7		
$\phi 40$	30	20	60	80	7.0	6.5	11.5	10.5	28.3	29.5	12	34	46	(stroke length/3.25) + 7		

- SCP*2
- CMK2
- CMA2
- SCM
- SCG
- SCA2
- SCS
- CKV2
- CA/OV2
- SSD
- CAT
- MDC2
- MVC
- SMD2
- MSD*
- FC*
- STK
- ULK*
- JSK/M2
- JSG
- JSC3
- USSD
- USC
- JSB3
- LMB
- STG
- STS/L
- LCS
- LCG
- LCM
- LCT
- LCY
- STR2
- UCA2
- HCM
- HCA
- SRL2
- SRG
- SRM
- SRT
- MRL2
- MRG2
- SM-25
- CAC3
- UCAC
- RCC2
- MFC
- SHC
- GLC
- Ending

Medium bore size cylinder
Standard type

Dimensions

● Rod side trunnion type (TA)

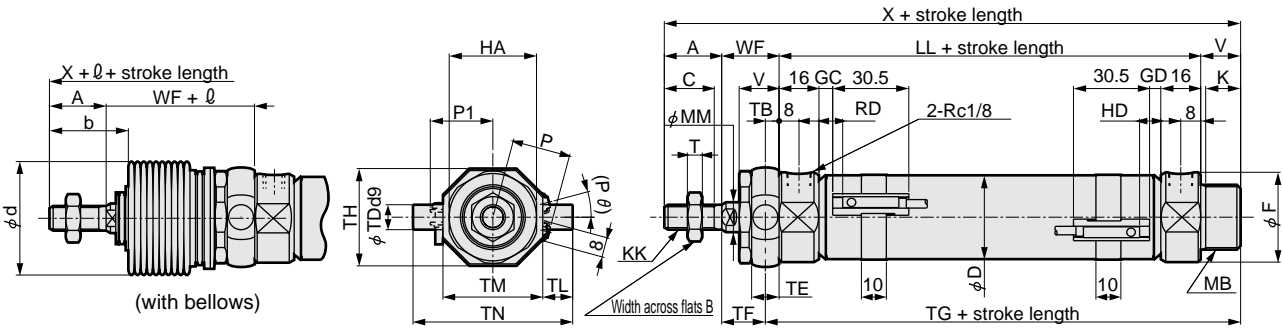

Note 1: For ℓ dimensions, round up decimal point or less.

Note 2: Refer to page 188 for the HD, RD, and projecting dimensions of the T1* and T8* switches and 2-color indicator switch with preventive maintenance output.

Note 3: Refer to page 190 for dimensions of accessories.

Symbol	Rod side trunnion type (TA) basic dimensions															Installation dimensions	
Bore size (mm)	A	B	C	D	F	HA	K	KK	LL	MB	MM	T	V	WF	X	TB	TD
$\phi 20$	20	13	18	21.4	28	26	12	M8 x 1.0	66	M18 x 1.5	10	5	14	24	124	4.5	$8^{+0.040}_{-0.076}$
$\phi 25$	23	17	20	26.4	32	35	14	M10 x 1.25	69	M26 x 1.5	12	6	16	23	131	5.5	$10^{+0.040}_{-0.076}$
$\phi 32$	23	17	20	33.6	36	35	14	M10 x 1.25	69	M26 x 1.5	12	6	16	23	131	5.5	$10^{+0.040}_{-0.076}$
$\phi 40$	25	19	22	41.6	45	35	14	M12 x 1.5	73	M26 x 1.5	14	7	16	23	137	5.5	$10^{+0.040}_{-0.076}$
Symbol	With switch												With bellows				
Bore size (mm)	TE	TF	TG	TH	TL	TM	TN	GC	GD	RD	HD	P	P1	(P θ)°	b	d	ℓ
$\phi 20$	9	19.5	84.5	29.5	8	30	46	4.0	3.0	8.0	7.0	17.3	19.5	22	30	30	(stroke length/3) + 6
$\phi 25$	11	17.5	90.5	39	12	40	64	5.5	4.5	9.5	8.5	19.8	22.0	18	32	46	(stroke length/3.25) + 7
$\phi 32$	11	17.5	90.5	39	12	40	64	5.5	4.5	9.5	8.5	24.3	25.5	15	32	46	(stroke length/3.25) + 7
$\phi 40$	11	17.5	94.5	44	9.5	53	72	7.0	6.5	11.5	10.5	28.3	29.5	12	34	46	(stroke length/3.25) + 7

● Rod side trunnion type (TA) with bracket (option symbol B2)

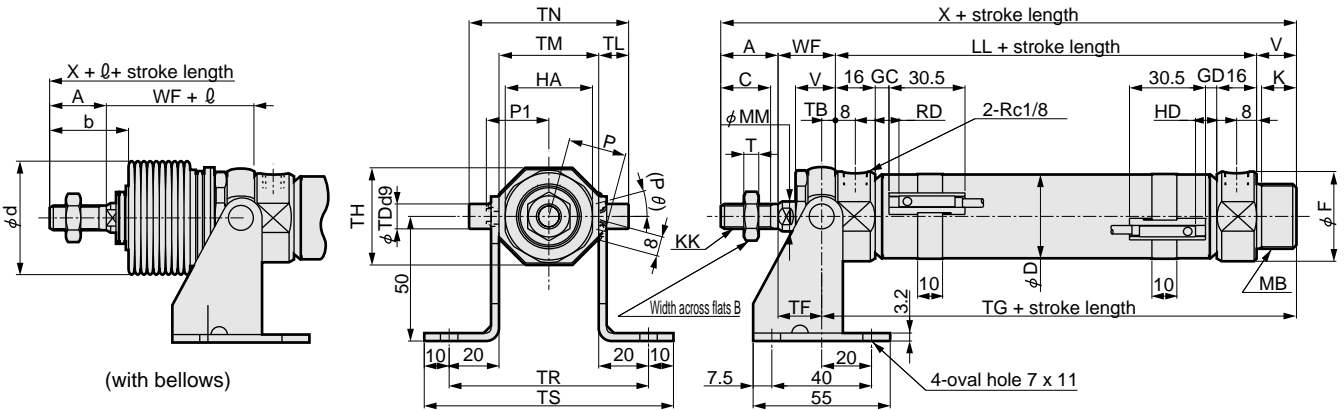

Note 1: For ℓ dimensions, round up decimal point or less.

Note 2: Refer to page 188 for the HD, RD, and projecting dimensions of the T1* and T8* switches and 2-color indicator switch with preventive maintenance output.

Note 3: Refer to page 190 for dimensions of accessories.

Symbol	Rod side trunnion type (TA) with bracket (option symbol B2) basic dimensions															Installation dimensions		
Bore size (mm)	A	B	C	D	F	HA	K	KK	LL	MB	MM	T	V	WF	X	TB	TD	TF
$\phi 20$	20	13	18	21.4	28	26	12	M8 x 1.0	66	M18 x 1.5	10	5	14	24	124	4.5	$8^{+0.040}_{-0.076}$	19.5
$\phi 25$	23	17	20	26.4	32	35	14	M10 x 1.25	69	M26 x 1.5	12	6	16	23	131	5.5	$10^{+0.040}_{-0.076}$	17.5
$\phi 32$	23	17	20	33.6	36	35	14	M10 x 1.25	69	M26 x 1.5	12	6	16	23	131	5.5	$10^{+0.040}_{-0.076}$	17.5
$\phi 40$	25	19	22	41.6	45	35	14	M12 x 1.5	73	M26 x 1.5	14	7	16	23	137	5.5	$10^{+0.040}_{-0.076}$	17.5
Symbol	With switch												With bellows					
Bore size (mm)	TG	TH	TL	TM	TN	TR	TS	GC	GD	RD	HD	P	P1	(P θ)°	b	d	ℓ	
$\phi 20$	84.5	29.5	8	30	46	70	90	4.0	3.0	8.0	7.0	17.3	19.5	22	30	30	(stroke length/3) + 6	
$\phi 25$	90.5	39	12	40	64	80	100	5.5	4.5	9.5	8.5	19.8	22.0	18	32	46	(stroke length/3.25) + 7	
$\phi 32$	90.5	39	12	40	64	80	100	5.5	4.5	9.5	8.5	24.3	25.5	15	32	46	(stroke length/3.25) + 7	
$\phi 40$	94.5	44	9.5	53	72	93	113	7.0	6.5	11.5	10.5	28.3	29.5	12	34	46	(stroke length/3.25) + 7	

Dimensions

● Head side trunnion type (TB)

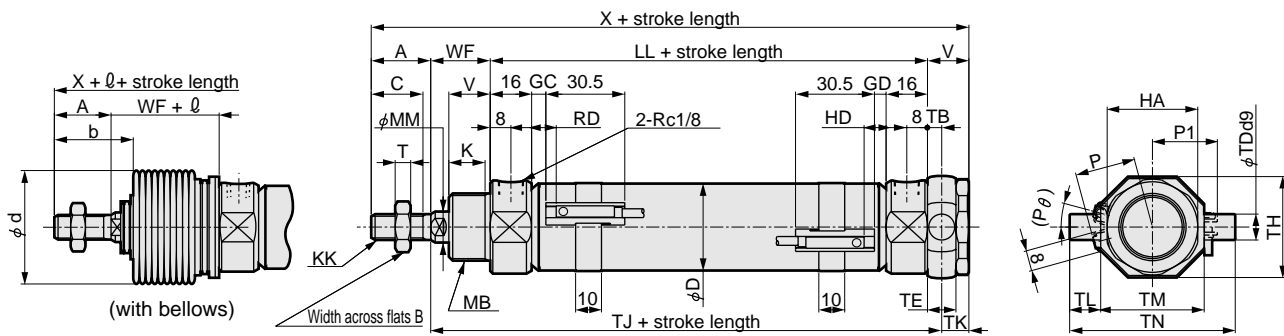

Note 1: For ℓ dimensions, round up decimal point or less.

Note 2: Refer to page 188 for the HD, RD, and projecting dimensions of the T1* and T8* switches and 2-color indicator switch with preventive maintenance output.

Note 3: Refer to page 190 for dimensions of accessories.

Symbol	Head side trunnion type (TB) basic dimensions														Installation dimensions		
Bore size (mm)	A	B	C	D	HA	K	KK	LL	MB	MM	T	V	WF	X	TB	TD	TE
φ20	20	13	18	21.4	26	12	M8 x 1.0	66	M18 x 1.5	10	5	14	24	124	4.5	8 ^{-0.040} _{-0.076}	9
φ25	23	17	20	26.4	35	14	M10 x 1.25	69	M26 x 1.5	12	6	16	23	131	5.5	10 ^{-0.040} _{-0.076}	11
φ32	23	17	20	33.6	35	14	M10 x 1.25	69	M26 x 1.5	12	6	16	23	131	5.5	10 ^{-0.040} _{-0.076}	11
φ40	25	19	22	41.6	35	14	M12 x 1.5	73	M26 x 1.5	14	7	16	23	137	5.5	10 ^{-0.040} _{-0.076}	11
Symbol	With switch												With bellows				
Bore size (mm)	TH	TJ	TK	TL	TM	TN	GC	GD	RD	HD	P	P1	(Pθ)°	b	d	ℓ	
φ20	29.5	94.5	9.5	8	30	46	4.0	3.0	8.0	7.0	17.3	19.5	22	30	30	(stroke length/3) + 6	
φ25	39	97.5	10.5	12	40	64	5.5	4.5	9.5	8.5	19.8	22.0	18	32	46	(stroke length/3.25) + 7	
φ32	39	97.5	10.5	12	40	64	5.5	4.5	9.5	8.5	24.3	25.5	15	32	46	(stroke length/3.25) + 7	
φ40	44	101.5	10.5	9.5	53	72	7.0	6.5	11.5	10.5	28.3	29.5	12	34	46	(stroke length/3.25) + 7	

● Head side trunnion type (TB) with bracket (option symbol B2)

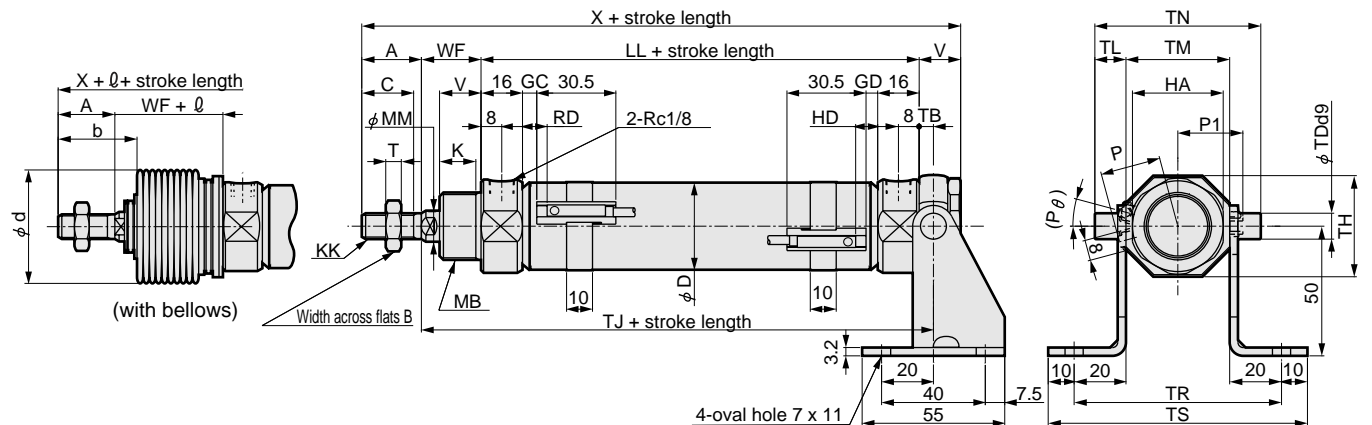

Note 1: For ℓ dimensions, round up decimal point or less.

Note 2: Refer to page 188 for the HD, RD, and projecting dimensions of the T1* and T8* switches and 2-color indicator switch with preventive maintenance output.

Note 3: Refer to page 190 for dimensions of accessories.

Symbol	Head side trunnion type (TB) with bracket (option symbol B2) basic dimensions														Installation dimensions		
Bore size (mm)	A	B	C	D	HA	K	KK	LL	MB	MM	T	V	WF	X	TB	TD	TH
φ20	20	13	18	21.4	26	12	M8 x 1.0	66	M18 x 1.5	10	5	14	24	124	4.5	8 ^{-0.040} _{-0.076}	29.5
φ25	23	17	20	26.4	35	14	M10 x 1.25	69	M26 x 1.5	12	6	16	23	131	5.5	10 ^{-0.040} _{-0.076}	39
φ32	23	17	20	33.6	35	14	M10 x 1.25	69	M26 x 1.5	12	6	16	23	131	5.5	10 ^{-0.040} _{-0.076}	39
φ40	25	19	22	41.6	35	14	M12 x 1.5	73	M26 x 1.5	14	7	16	23	137	5.5	10 ^{-0.040} _{-0.076}	44
Symbol	With switch												With bellows				
Bore size (mm)	TJ	TL	TM	TN	TR	TS	GC	GD	RD	HD	P	P1	(Pθ)°	b	d	ℓ	
φ20	94.5	8	30	46	70	90	4.0	3.0	8.0	7.0	17.3	19.5	22	30	30	(stroke length/3) + 6	
φ25	97.5	12	40	64	80	100	5.5	4.5	9.5	8.5	19.8	22.0	18	32	46	(stroke length/3.25) + 7	
φ32	97.5	12	40	64	80	100	5.5	4.5	9.5	8.5	24.3	25.5	15	32	46	(stroke length/3.25) + 7	
φ40	101.5	9.5	53	72	93	113	7.0	6.5	11.5	10.5	28.3	29.5	12	34	46	(stroke length/3.25) + 7	

- SCP*2
- CMK2
- CMA2
- SCM
- SCG
- SCA2
- SCS
- CKV2
- CA/OV2
- SSD
- CAT
- MDC2
- MVC
- SMD2
- MSD*
- FC*
- STK
- ULK*
- JSK/M2
- JSG
- JSC3
- USSD
- USC
- JSB3
- LMB
- STG
- STS/L
- LCS
- LCG
- LCM
- LCT
- LCY
- STR2
- UCA2
- HCM
- HCA
- SRL2
- SRG
- SRM
- SRT
- MRL2
- MRG2
- SM-25
- CAC3
- UCAC
- RCC2
- MFC
- SHC
- GLC
- Ending

Medium bore size cylinder
Standard type

SCP*2
CMK2
 CMA2
 SCM
 SCG
 SCA2
 SCS
 CKV2
 CA/OV2
 SSD
 CAT
 MDC2
 MVC
 SMD2
 MSD*
 FC*
 STK
 ULK*
 JSK/M2
 JSG
 JSC3
 USSD
 USC
 JSB3
 LMB
 STG
 STS/L
 LCS
 LCG
 LCM
 LCT
 LCY
 STR2
 UCA2
 HCM
 HCA
 SRL2
 SRG
 SRM
 SRT
 MRL2
 MRG2
 SM-25
 CAC3
 UCAC
 RCC2
 MFC
 SHC
 GLC
 Ending

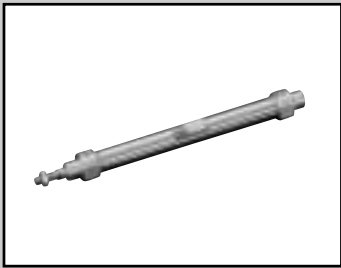

Medium bore size cylinder
 Single acting extend type
CMK2-S Series

● Bore size: $\phi 20$, $\phi 25$, $\phi 32$, $\phi 40$

JIS symbol ● Single acting cylinder extend type

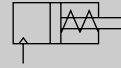

Specifications

Descriptions		CMK2-S			
Bore size	mm	$\phi 20$	$\phi 25$	$\phi 32$	$\phi 40$
Actuation		Single acting extend type			
Working fluid		Compressed air			
Max. working pressure	MPa	1.0			
Min. working pressure	MPa	0.2			
Withstanding pressure	MPa	1.6			
Ambient temperature	°C	-10 to 60 (no freezing)			
Port size		Rc1/8			
Stroke tolerance	mm	$^{+2.0}_0$ (To 200), $^{+2.4}_0$ (200 over to)			
Working piston speed	mm/s	50 to 500			
Cushion		Rubber cushion			
Lubrication		Not required (when lubricating, use turbine oil Class 1 ISO VG32.)			
Allowable energy absorption	J	0.166	0.308	0.424	0.639

Note: Do not leave a single acting cylinder under elevated pressure. Failure to observe this may result that the piston rod does not return by spring force when pressure is released.

Stroke length

Bore size (mm)	Standard stroke length (mm)	Max. stroke length (mm)	Min. stroke length (mm)
$\phi 20$	25, 50, 75, 100, 150	300	5
$\phi 25$			
$\phi 32$	25, 50, 75, 100,		
$\phi 40$	150, 200		

Note 1: Custom stroke length is available per 1 mm increment.
 Note 2: For single foot type (LS type), maximum stroke length is 50 mm.
 Note 3: For bellows "J" type, stroke length should be longer than 25 mm.
 Consult with CKD when stroke length is shorter than 25 mm.

Min. stroke length of type with switch

(Unit: mm)

Switch quantity	1					2				3			
	Proximity		Reed			Proximity		Reed		Proximity		Reed	
	T2, T3	T1, T*Y*	T0, T5	T8	T2, T3	T1, T*Y*	T0, T5	T8	T2, T3	T1, T*Y*	T0, T5	T8	
$\phi 20$	10					25	35	25	35	50	55	50	55
$\phi 25$	10					25	35	25	35	50	55	50	55
$\phi 32$	10					25	35	25	35	50	55	50	55
$\phi 40$	10					25	35	25	35	50	55	50	55

Note 1: Up to three switches can be mounted.

Switch specifications

- 1 color/2 color indicator

* The T0/T5 switch can be used with 220 VAC. Contact CKD for working conditions.

Descriptions	Proximity 2-wire			Proximity 3-wire			Reed 2-wire						
	T1H/T1V	T2H/T2V/ T2JH/T2JV	T2YH/ T2YV	T3H/ T3V	T3PH/T3PV (Custom order)	T3YH/ T3YV	TOH/TOV		T5H/T5V		T8H/T8V		
Applications	Programmable controller Relay, small solenoid valve	Programmable controller dedicated		Programmable controller, relay			Programmable controller, relay		Programmable controller, relay, IC circuit (w/o light), serial connection		Programmable controller, relay		
Output method	-			NPN output	PNP output	NPN output	-						
Power voltage	-			10 to 28 VDC			-						
Load voltage	85 to 265 VAC	10 to 30 VDC		30 VDC or less			12/24 VDC	110 VAC	5/12/24 VDC	110 VAC	12/24 VDC	110 VAC	220 VAC
Load current	5 to 100 mA	5 to 20 mA (Note 1)		100 mA or less		50 mA or less	5 to 50 mA	7 to 20 mA	50 mA or less	20 mA or less	5 to 50 mA	7 to 20 mA	7 to 10 mA
Light	LED (ON lighting)	LED (ON lighting)	Red/green LED (ON lighting)	LED (ON lighting)	Green LED (ON lighting)	Red/Green LED (ON lighting)	LED (ON lighting)		Without indicator light		LED (ON lighting)		
Leakage current	1 mA or less with 100 VAC 2 mA or less with 200 VAC	1 mA or less		10 μA or less			0 mA						

- With preventive maintenance output

Descriptions	Proximity 3-wire		Proximity 4-wire		Proximity 3-wire		Proximity 4-wire		
	T2YFH/V		T3YFH/V		T2YMH/V		T3YMH/V		
Applications	Programmable controller dedicated		Programmable controller, relay		Programmable controller dedicated		Programmable controller, relay		
Output method	NPN output								
Light	Red/Green LED (ON lighting)								
	Installation position adjustment		-						Yellow LED (ON lighting)
Regular Output section	Power voltage		10 to 28 VDC		-		10 to 28 VDC		
	Load voltage		30 VDC or less		10 to 30 VDC		30 VDC or less		
	Load current		50 mA or less		5 to 20 mA		50 mA or less		
	Leakage current		10 μA or less		1.2 mA or less		10 μA or less		
Preventive maintenance Output section	30 VDC or less								
	Load current		50 mA or less		5 to 20 mA or less		50 mA or less		
	Leakage current		10 μA or less						

Note 1: Refer to Ending 1 for other switches.

Note 2: The above maximum load current of 20 mA applies at 25 °C. If the switch's working ambient temperature exceeds 25 °C, the load current will be lower than 20 mA. (5 to 10 mA when 60 °C)

Cylinder weight

(Unit: kg)

Descriptions/ mounting style	Product weight when stroke length (S) = 0 mm								Switch weight Grommet	Switch rail + band weight	Additional weight per S = 10 mm
	Basic (00)	Axial foot (LB)	Axial foot (LS)	Flange (FA/FB)	Eye bracket (CA)	Clevis (CC)	Clevis bracket (CB)	Trunnion (TA/TB)			
φ 20	0.17	0.32	0.25	0.23	0.32	0.18	0.32	0.22	0.018	0.005	0.01
φ 25	0.26	0.52	0.39	0.41	0.50	0.26	0.50	0.36	0.018	0.005	0.01
φ 32	0.30	0.56	0.43	0.45	0.54	0.30	0.54	0.40	0.018	0.009	0.02
φ 40	0.48	0.74	0.61	0.63	0.72	0.50	0.72	0.64	0.018	0.009	0.02

Descriptions/mounting style	Stroke length (S) additional weight							
	25 or less	25 to 50	50 to 75	75 to 100	100 to 150	150 to 200	200 to 250	250 to 300
φ 20	0.04	0.05	0.09	0.09	0.14	0.18	0.23	0.27
φ 25	0.05	0.06	0.12	0.12	0.18	0.24	0.29	0.35
φ 32	0.09	0.11	0.23	0.22	0.32	0.43	0.53	0.64
φ 40	0.13	0.16	0.31	0.31	0.47	0.62	0.78	0.93

(E.g.) Product weight of CMK2-S-FA-32-50-TOH-D

When S = 0 mm, product weight is 0.45 kg
 Additional weight at S = 50 mm is additional weight at S = 10 mm 0.02 X $\frac{\text{Product stroke length (50)}}{10}$ = 0.10 kg
 Additional weight for each S: 0.11 kg
 Weight of two switches is 0.036 kg
 Weight of switch rail and two bands is 0.018 kg
 Product weight is 0.45 kg + 0.10 kg + 0.10 kg + 0.036 kg + 0.018 kg = 0.704 kg

SCP*2
 CMK2
 CMA2
 SCM
 SCG
 SCA2
 SCS
 CKV2
 CA/OV2
 SSD
 CAT
 MDC2
 MVC
 SMD2
 MSD*
 FC*
 STK
 ULK*
 JSK/M2
 JSG
 JSC3
 USSD
 USC
 JSB3
 LMB
 STG
 STS/L
 LCS
 LCG
 LCM
 LCT
 LCY
 STR2
 UCA2
 HCM
 HCA
 SRL2
 SRG
 SRM
 SRT
 MRL2
 MRG2
 SM-25
 CAC3
 UCAC
 RCC2
 MFC
 SHC
 GLC

Ending

Medium bore size cylinder
 Standard type

SCP*2
CMK2
CMA2
SCM
SCG
SCA2
SCS
CKV2
CA/OV2
SSD
CAT
MDC2
MVC
SMD2
MSD*
FC*
STK
ULK*
JSK/M2
JSG
JSC3
USSD
USC
JSB3
LMB
STG
STS/L
LCS
LCG
LCM
LCT
LCY
STR2
UCA2
HCM
HCA
SRL2
SRG
SRM
SRT
MRL2
MRG2
SM-25
CAC3
UCAC
RCC2
MFC
SHC
GLC
Ending

How to order

Without switch

CMK2-S - 00 - 20 - 100 - M I

With switch

CMK2-S - 00 - 20 - 100 - T0H - R - M I

A Mounting style
Note 1

B Bore size

C Port thread type

D Stroke length

E Switch model no.

F Switch quantity
Note 9

G Option
Note 3, Note 4,
Note 5

H Accessory
Note 6

Note on model no. selection

- Note 1: The maximum stroke of the single-end foot type (LS type) is 50 mm.
 Note 2: Refer to page 102 for min. stroke length with switch.
 Note 3: For bellows "J" type, stroke length should be longer than 25 mm. Consult with CKD when stroke length is shorter than 25 mm.
 Note 4: Applicable tube O.D. of F; push-in joint (straight), FE; push-in joint (elbow) is ϕ 6.
 Note 5: Instantaneous maximum temperature is the temperature when spark and spatter etc. instantaneously contacts to bellows.
 Note 6: "I" and "Y" can not be selected at the same time.
Note 7: Refer to Ending 89 for the custom order specifications of rod end form.
 Note 8: Refer to page 84 for variation and combinations of options.
 Note 9: Up to three switches can be mounted. If more than four switches are required, switch mounting brackets for the extra switches must be prepared separately.

<Example of model number>

CMK2-S-00-20-100-T0H-R-MI

Model: Medium bore size cylinder, single acting, extend type

- A** Mounting style : Basic type
- B** Bore size : ϕ 20 mm
- C** Port thread type : Rc thread
- D** Stroke length : 100 mm
- E** Switch model no. : Reed T0H switch and lead wire 1 m
- F** Switch quantity : One on rod end
- G** Option : Piston rod material change
- H** Accessory : Rod eye

Symbol	Descriptions
A Mounting style	
00	Basic type
LB	Axial foot type (both sides)
LS	Axial foot type (single)
FA	Rod side flange type
FB	Head side flange type
CA	Eye bracket type
CC	Fixed eye
CC1	Eye and bush press fitted type
CB	Clevis bracket type (pin and washer split pin attached)
TA	Rod side trunnion type
TB	Head side trunnion type

B Bore size (mm)	
20	ϕ 20
25	ϕ 25
32	ϕ 32
40	ϕ 40

C Port thread type	
Blank	Rc thread
NN	NPT thread (custom order)
GN	G thread (custom order)

D Stroke length (mm)		
Bore size	Stroke length Note 2	Custom stroke length
ϕ 20	5 to 300	By 1 mm increment
ϕ 25	5 to 300	
ϕ 32	5 to 300	
ϕ 40	5 to 300	

E Switch model no.				
Lead wire Straight type	Lead wire L type	Contact	Indicator	
			Reed	Proximity
T0H*	T0V*	Reed	1 color	2-wire
T5H*	T5V*		Without indicator light	
T8H*	T8V*		1 color	
T1H*	T1V*	Proximity	1 color	2-wire
T2H*	T2V*			
T3H*	T3V*			
T3PH*	T3PV*		1 color (custom order)	3-wire
T2YH*	T2YV*		2 color	2-wire
T3YH*	T3YV*			3-wire
T2YFH*	T2YFV*	2 color (w/o light for preventive maintenance output)	3-wire	
T3YFH*	T3YFV*		4 wire	
T2YMH*	T2YMV*		3-wire	
T3YMH*	T3YMV*		4 wire	
T2JH*	T2JV*		Off-delay type	2-wire

* Lead wire length	
Blank	1 m (standard)
3	3 m (option)
5	5 m (option)

F Switch quantity	
R	One on rod end
H	One on head end
D	Two
T	Three

G Option		:Max. ambient ;Max. instantaneous	
J	Bellows	100 °C	200 °C
L	Bellows	250 °C	400 °C
F	Push-in joint (straight)		
FE	Push-in joint (elbow)		
M	Piston rod material (stainless steel)		
V	Boss cut off		
P6	Copper and PTFE free		

H Accessory	
I	Rod eye
Y	Rod clevis (pin and washer split pin attached)
B2	Clevis bracket (pin and snap ring attached)

How to order switch

- Switch body + mounting bracket

CMK2 - **T0H** - **20**

Bore size (item ③ on previous page)

Switch model no. (item ② on previous page)

- Only switch body

SW - **T0H**

Switch model no. (item ② on previous page)

- Mounting bracket

CMK2 - **T** - **20**

Bore size (item ③ on previous page)

Bracket

How to order mounting bracket

Bore size (mm)	$\phi 20$	$\phi 25$	$\phi 32$	$\phi 40$
Axial foot type (LB/LS)	M1-LB-20	M1-LB-30	M1-LB-30	M1-LB-30
Flange (FA/FB)	M1-FA-20	M1-FA-30	M1-FA-30	M1-FA-30
Trunnion (TA/TB)	M1-TA-20	M1-TA-30	M1-TA-30	M1-TA-40
Eye bracket type (CA)	M1-CA-20	M1-CA-30	M1-CA-30	M1-CA-30
Clevis bracket type (CB)	M1-CB-20	M1-CB-30	M1-CB-30	M1-CB-30

Note 1: Mounting nut/toothed washer are attached to each mounting bracket.

Note 2: Two sets of "M1-LB-*" in the above table are required for the axial direction foot (double-sided).

SCP*2
CMK2
CMA2
SCM
SCG
SCA2
SCS
CKV2
CA/OV2
SSD
CAT
MDC2
MVC
SMD2
MSD*
FC*
STK
ULK*
JSK/M2
JSG
JSC3
USSD
USC
JSB3
LMB
STG
STS/L
LCS
LCG
LCM
LCT
LCY
STR2
UCA2
HCM
HCA
SRL2
SRG
SRM
SRT
MRL2
MRG2
SM-25
CAC3
UCAC
RCC2
MFC
SHC
GLC
Ending

Medium bore size cylinder
Standard type

Internal structure and parts list

● CMK2-S

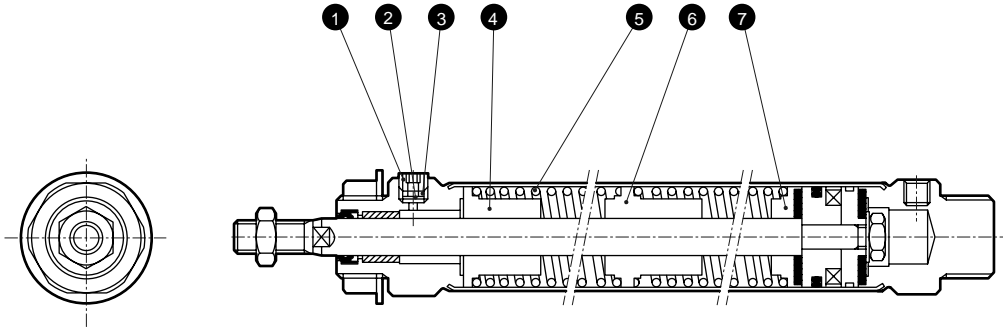

● Note: This caulking type cannot be disassembled.

No.	Parts name	Material	Remarks	No.	Parts name	Material	Remarks
1	Bush	6 nylon		5	Spring	Piano wire	Paint
2	Stainless steel wire net	Stainless steel		6	Spring holder	Special aluminum	
3	Element holder	Steel	Zinc chromate	7	Spring holder	Special aluminum	
4	Spring holder	Special aluminum					

Spring load

(Unit: N)

Bore size (mm)	Stroke length (mm)	25	50	75	100	150	200	250	300
φ20	Stroke length 0 mm	11.9	11.8	11.8	11.8	11.8	11.8	11.8	11.8
	Full stroke length	31	38	31.5	38	38	38	38	38
φ25	Stroke length 0 mm	12.1	12.5	12.5	12.5	12.5	12.5	12.5	12.5
	Full stroke length	30.4	40.2	33.1	40.2	40.2	40.2	40.2	40.2
φ32	Stroke length 0 mm	24.5	24.3	24.5	24.3	24.3	24.3	24.3	24.3
	Full stroke length	52.9	54.9	54.9	54.9	54.9	54.9	54.9	54.9
φ40	Stroke length 0 mm	28.4	28.4	28.4	28.4	28.4	28.4	28.4	28.4
	Full stroke length	78.4	100	82.3	100	100	100	100	100

Dimensions

- Single acting, extend type

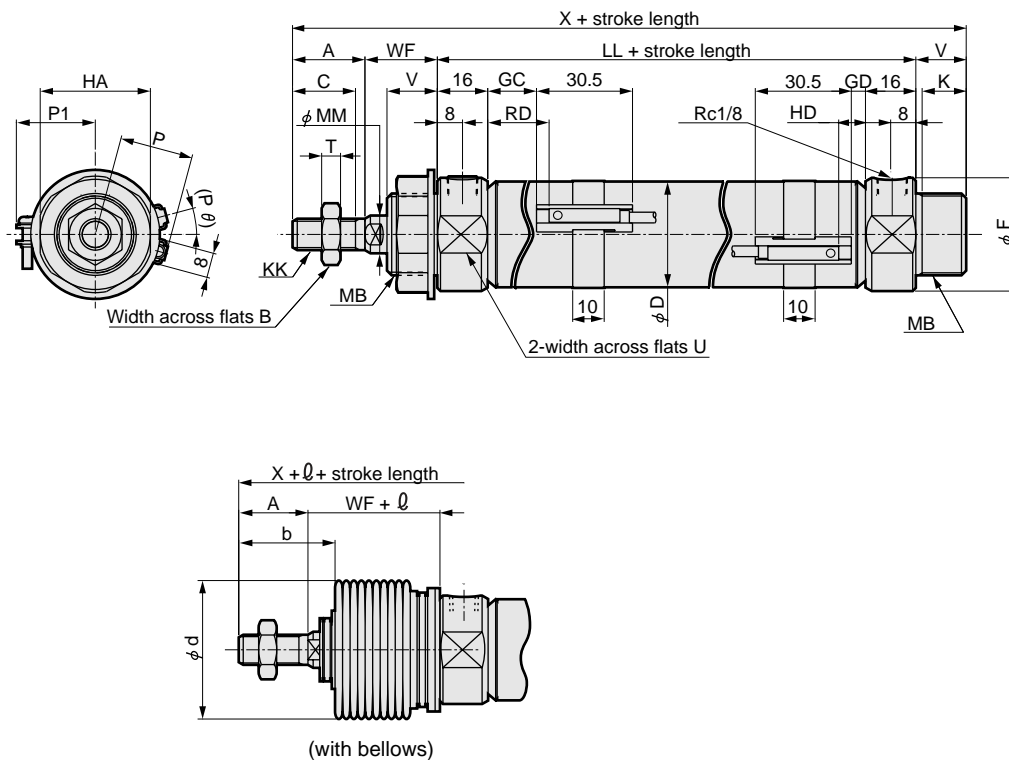

Note 1: Dimensions of each mounting type are same as standard type. Refer to pages 96 to 101.

Note 2: Refer to page 188 for the HD, RD, and projecting dimensions of the T1* and T8* switches and 2-color indicator switch with preventive maintenance output.

RD: Rod side max. sensitive position

Note 3: For ℓ dimensions, round up decimal point or less.

HD: Head side max. sensitive position

Note 4: Refer to page 190 for dimensions of accessories.

Symbol	Basic type (00) basic dimensions										LL						MB	MM	T
	A	B	C	D	F	HA	K	KK	25 or less	25 to 50	50 to 100	100 to 150	150 to 200	200 to 250	250 to 300				
ϕ 20	20	13	18	21.4	28	26	12	M8 x 1.0	91	93	120	147	174	201	228	M18 x 1.5	10	5	
ϕ 25	23	17	20	26.4	32	35	14	M10 x 1.25	94	99	129	159	189	219	249	M26 x 1.5	12	6	
ϕ 32	23	17	20	33.6	36	35	14	M10 x 1.25	94	99	129	159	189	219	249	M26 x 1.5	12	6	
ϕ 40	25	19	22	41.6	45	35	14	M12 x 1.5	98	103	133	163	193	223	253	M26 x 1.5	14	7	

Symbol	X										With switch		RD							
	U	V	WF	25 or less	25 to 50	50 to 100	100 to 150	150 to 200	200 to 250	250 to 300	GC	GD	25 or less	25 to 50	50 to 100	100 to 150	150 to 200	200 to 250	250 to 300	
ϕ 20	24	14	24	149	151	178	205	232	259	256	4.0	3.0	33.0	35.0	62.0	89.0	116.0	143.0	170.0	
ϕ 25	30	16	23	156	161	191	221	251	281	311	5.5	4.5	34.5	39.5	69.5	99.5	129.5	159.5	189.5	
ϕ 32	34	16	23	156	161	191	221	251	281	311	5.5	4.5	34.5	39.5	69.5	99.5	129.5	159.5	189.5	
ϕ 40	43	16	23	162	167	197	227	257	287	317	7.0	6.5	36.5	41.5	71.5	101.5	131.5	161.5	191.5	

Symbol	With bellows						
	HD	P	P1	(P θ)°	b	d	
ϕ 20	7.0	17.3	19.5	22	30	30	(stroke length/3) + 6
ϕ 25	8.5	19.8	22.0	18	32	46	(stroke length/3.25) + 7
ϕ 32	8.5	24.3	25.5	15	32	46	(stroke length/3.25) + 7
ϕ 40	10.5	28.3	29.5	12	34	46	(stroke length/3.25) + 7

SCP*2
CMK2
 CMA2
 SCM
 SCG
 SCA2
 SCS
 CKV2
 CA/OV2
 SSD
 CAT
 MDC2
 MVC
 SMD2
 MSD*
 FC*
 STK
 ULK*
 JSK/M2
 JSG
 JSC3
 USSD
 USC
 JSB3
 LMB
 STG
 STS/L
 LCS
 LCG
 LCM
 LCT
 LCY
 STR2
 UCA2
 HCM
 HCA
 SRL2
 SRG
 SRM
 SRT
 MRL2
 MRG2
 SM-25
 CAC3
 UCAC
 RCC2
 MFC
 SHC
 GLC
 Ending
 Medium bore size cylinder
 Standard type

SCP*2
CMK2
 CMA2
 SCM
 SCG
 SCA2
 SCS
 CKV2
 CA/OV2
 SSD
 CAT
 MDC2
 MVC
 SMD2
 MSD*
 FC*
 STK
 ULK*
 JSK/M2
 JSG
 JSC3
 USSD
 USC
 JSB3
 LMB
 STG
 STS/L
 LCS
 LCG
 LCM
 LCT
 LCY
 STR2
 UCA2
 HCM
 HCA
 SRL2
 SRG
 SRM
 SRT
 MRL2
 MRG2
 SM-25
 CAC3
 UCAC
 RCC2
 MFC
 SHC
 GLC
 Ending

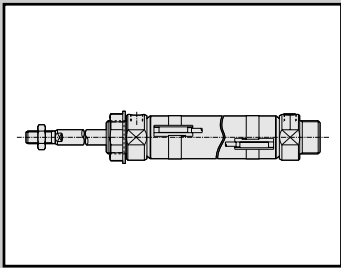

Medium bore size cylinder
 Single acting retract type

CMK2-SR Series

● Bore size: $\phi 20$, $\phi 25$, $\phi 32$, $\phi 40$

JIS symbol ● Single acting cylinder retract type



Specifications

Descriptions		CMK2-SR			
Bore size	mm	$\phi 20$	$\phi 25$	$\phi 32$	$\phi 40$
Actuation		Single acting retract type			
Working fluid		Compressed air			
Max. working pressure	MPa	1.0			
Min. working pressure	MPa	0.2			
Withstanding pressure	MPa	1.6			
Ambient temperature	°C	-10 to 60 (no freezing)			
Port size		Rc1/8			
Stroke tolerance	mm	$^{+2.0}_0$ (up to 200), $^{+2.4}_0$ (over 200)			
Working piston speed	mm/s	50 to 500			
Cushion		Rubber cushion			
Lubrication		Not required (when lubricating, use turbine oil Class 1 ISO VG32.)			
Allowable energy absorption	J	0.166	0.308	0.424	0.639

Note: Do not leave a single acting cylinder under elevated pressure. Failure to observe this may result that the piston rod does not return by spring force when pressure is released.

Stroke length

Bore size (mm)	Standard stroke length (mm)	Max. stroke length (mm)	Min. stroke length (mm)
$\phi 20$	25, 50, 75, 100, 150	300	5
$\phi 25$			
$\phi 32$	25, 50, 75, 100,		
$\phi 40$	150, 200		

Note 1: Custom stroke length is available per 1 mm increment.

Note 2: For single foot type (LS type), maximum stroke length is 50 mm.

Note 3: For bellows "J" type, stroke length should be longer than 25 mm.

Consult with CKD when stroke length is shorter than 25 mm.

Min. stroke length of type with switch

(Unit: mm)

Switch quantity	1					2				3			
	Proximity		Reed			Proximity		Reed		Proximity		Reed	
	T2, T3	T1, T*Y*	T0, T5	T8	T2, T3	T1, T*Y*	T0, T5	T8	T2, T3	T1, T*Y*	T0, T5	T8	
Bore size (mm)													
$\phi 20$	10					25	35	25	35	50	55	50	55
$\phi 25$	10					25	35	25	35	50	55	50	55
$\phi 32$	10					25	35	25	35	50	55	50	55
$\phi 40$	10					25	35	25	35	50	55	50	55

Note 1: Up to three switches can be mounted.

Switch specifications

- 1 color/2 color indicator

* The T0/T5 switch can be used with 220 VAC. Contact CKD for working conditions.

Descriptions	Proximity 2-wire			Proximity 3-wire			Reed 2-wire						
	T1H/T1V	T2H/T2V/ T2JH/T2JV	T2YH/ T2YV	T3H/ T3V	T3PH/T3PV (Custom order)	T3YH/ T3YV	T0H/T0V		T5H/T5V		T8H/T8V		
Applications	Programmable controller Relay, small solenoid valve		Programmable controller dedicated	Programmable controller, relay			Programmable controller, relay		Programmable controller, relay, IC circuit (w/o light), serial connection		Programmable controller, relay		
Output method	-			NPN output	PNP output	NPN output	-						
Power voltage	-			10 to 28 VDC			-						
Load voltage	85 to 265 VAC		10 to 30 VDC	30 VDC or less			12/24 VDC	110 VAC	5/12/24 VDC	110 VAC	12/24 VDC	110 VAC	220 VAC
Load current	5 to 100 mA		5 to 20 mA (Note 1)	100 mA or less		50 mA or less	5 to 50 mA	7 to 20 mA	50 mA or less	20 mA or less	5 to 50 mA	7 to 20 mA	7 to 10 mA
Light	LED (ON lighting)		LED (ON lighting)	Red/green LED (ON lighting)	LED (ON lighting)	Green LED (ON lighting)	Red/Green LED (ON lighting)	LED (ON lighting)		Without indicator light		LED (ON lighting)	
Leakage current	1 mA or less with 100 VAC 2 mA or less with 200 VAC		1 mA or less	10 μA or less			0 mA						

- With preventive maintenance output

Descriptions	Proximity 3-wire		Proximity 4-wire		Proximity 3-wire		Proximity 4-wire	
	T2YFH/V		T3YFH/V		T2YMH/V		T3YMH/V	
Applications	Programmable controller dedicated		Programmable controller, relay		Programmable controller dedicated		Programmable controller, relay	
Output method	NPN output							
Light	Red/Green LED (ON lighting)							
	Installation position adjustment		-		Yellow LED (ON lighting)			
Regular Output section	Power voltage		10 to 28 VDC		-		10 to 28 VDC	
	Load voltage		30 VDC or less		10 to 30 VDC		30 VDC or less	
	Load current		50 mA or less		5 to 20 mA		50 mA or less	
	Leakage current		10 μA or less		1.2 mA or less		10 μA or less	
Preventive maintenance Output section	30 VDC or less							
	Load voltage		50 mA or less		5 to 20 mA or less		50 mA or less	
	Load current		10 μA or less		-			

Note 1: Refer to Ending 1 for other switches.

Note 2: The above maximum load current of 20 mA applies at 25 °C. If the switch's working ambient temperature exceeds 25 °C, the load current will be lower than 20 mA. (5 to 10 mA when 60 °C)

Cylinder weight

(Unit: kg)

Descriptions/mounting style	Product weight when stroke length (S) = 0 mm								Switch weight	Switch rail	Additional weight per S = 10 mm
	Basic (00)	Axial foot (LB)	Axial foot (LS)	Flange (FA/FB)	Eye bracket (CA)	Clevis (CC)	Clevis bracket (CB)	Trunnion (TA/TB)	Grommet	+ band weight	
φ20	0.17	0.32	0.25	0.23	0.32	0.18	0.32	0.22	0.018	0.005	0.01
φ25	0.26	0.52	0.39	0.41	0.50	0.26	0.50	0.36	0.018	0.005	0.01
φ32	0.30	0.56	0.43	0.45	0.54	0.30	0.54	0.40	0.018	0.009	0.02
φ40	0.48	0.74	0.61	0.63	0.72	0.50	0.72	0.64	0.018	0.009	0.02

Descriptions/mounting style	Stroke length (S) additional weight							
	25 or less	25 to 50	50 to 75	75 to 100	100 to 150	150 to 200	200 to 250	250 to 300
φ20	0.03	0.03	0.06	0.06	0.09	0.12	0.15	0.18
φ25	0.03	0.04	0.07	0.07	0.11	0.14	0.18	0.21
φ32	0.08	0.09	0.18	0.17	0.25	0.34	0.42	0.51
φ40	0.10	0.13	0.25	0.25	0.37	0.49	0.62	0.74

(E.g.) Product weight of CMK2-SR-FA-32-50-T0H-D
 When S = 0 mm, product weight is 0.45 kg
 Additional weight at S = 50 mm is additional weight at S = 10 mm 0.02 X $\frac{\text{Product stroke length (50)}}{10} = 0.10$ kg
 Additional weight for each S: 0.09 kg
 Weight of two switches is 0.036 kg
 Weight of switch rail and two bands is 0.018 kg
 Product weight is 0.45 kg + 0.09 kg + 0.10 kg + 0.036 kg + 0.018 kg = 0.694 kg

SCP*2
 CMK2
 CMA2
 SCM
 SCG
 SCA2
 SCS
 CKV2
 CA/OV2
 SSD
 CAT
 MDC2
 MVC
 SMD2
 MSD*
 FC*
 STK
 ULK*
 JSK/M2
 JSG
 JSC3
 USSD
 USC
 JSB3
 LMB
 STG
 STS/L
 LCS
 LCG
 LCM
 LCT
 LCY
 STR2
 UCA2
 HCM
 HCA
 SRL2
 SRG
 SRM
 SRT
 MRL2
 MRG2
 SM-25
 CAC3
 UCAC
 RCC2
 MFC
 SHC
 GLC
 Ending

Medium bore size cylinder
 Standard type

CMK2-SR Series

- SCP*2
- CMK2**
- CMA2
- SCM
- SCG
- SCA2
- SCS
- CKV2
- CA/OV2
- SSD
- CAT
- MDC2
- MVC
- SMD2
- MSD*
- FC*
- STK
- ULK*
- JSK/M2
- JSG
- JSC3
- USSD
- USC
- JSB3
- LMB
- STG
- STS/L
- LCS
- LCG
- LCM
- LCT
- LCY
- STR2
- UCA2
- HCM
- HCA
- SRL2
- SRG
- SRM
- SRT
- MRL2
- MRG2
- SM-25
- CAC3
- UCAC
- RCC2
- MFC
- SHC
- GLC
- Ending

How to order

Without switch



With switch



A Mounting style
Note 1

B Bore size

C Port thread type

D Stroke length

E Switch model no.

F Switch quantity
Note 9

G Option
Note 3
Note 4
Note 5

H Accessory
Note 6

Note on model no. selection

- Note 1: The maximum stroke of the single-end foot type (LS type) is 50 mm.
- Note 2: Refer to page 108 for min. stroke length with switch.
- Note 3: For bellows "J" type, stroke length should be longer than 25 mm. Consult with CKD when stroke length is shorter than 25 mm.
- Note 4: Applicable tube O.D. of F; push-in joint (straight), FE; push-in joint (elbow) is ϕ 6.
- Note 5: Instantaneous maximum temperature is the temperature when spark and spatter etc. instantaneously contacts to bellows.
- Note 6: "I" and "Y" can not be selected at the same time.
- Note 7: Refer to Ending 89 for the custom order specifications of rod end form.
- Note 8: Refer to page 84 for variation and combinations of options.
- Note 9: Up to three switches can be mounted. If more than four switches are required, switch mounting brackets for the extra switches must be prepared separately.

<Example of model number>

CMK2-SR-00-20-100-T0H-R-MI

Model: Medium bore size cylinder, single acting, retract type

- A** Mounting style : Basic type
- B** Bore size : ϕ 20 mm
- C** Port thread type : Rc thread
- D** Stroke length : 100 mm
- E** Switch model no. : Reed T0H switch and lead wire 1 m
- F** Switch quantity : One on rod end
- G** Option : Piston rod material change
- H** Accessory : Rod eye

Symbol	Descriptions
A Mounting style	
00	Basic type
LB	Axial foot type (both sides)
LS	Axial foot type (single)
FA	Rod side flange type
FB	Head side flange type
CA	Eye bracket type
CC	Fixed eye
CC1	Eye and bush press fitted type
CB	Clevis bracket type (pin and washer split pin attached)
TA	Rod side trunnion type
TB	Head side trunnion type

B Bore size (mm)	
20	ϕ 20
25	ϕ 25
32	ϕ 32
40	ϕ 40

C Port thread type	
Blank	Rc thread
NN	NPT thread (custom order)
GN	G thread (custom order)

D Stroke length (mm)		
Bore size	Stroke length Note 2	Custom stroke length
ϕ 20	5 to 300	By 1 mm increment
ϕ 25	5 to 300	
ϕ 32	5 to 300	
ϕ 40	5 to 300	

E Switch model no.				
Lead wire Straight type	Lead wire L type	Contact Reed	Indicator	
			Lead wire	Lead wire
T0H*	T0V*	Reed	1 color	2-wire
T5H*	T5V*		Without indicator light	
T8H*	T8V*		1 color	
T1H*	T1V*	Proximity	1 color	2-wire
T2H*	T2V*			
T3H*	T3V*		1 color (custom order)	3-wire
T3PH*	T3PV*			
T2YH*	T2YV*		2 color	2-wire
T3YH*	T3YV*			
T2YFH*	T2YFV*	2 color (w/o light for preventive maintenance output)	3-wire	
T3YFH*	T3YFV*		4 wire	
T2YMH*	T2YMV*	2 color (w/ light for preventive maintenance output (1 color))	3-wire	
T3YMH*	T3YMV*		4 wire	
T2JH*	T2JV*	Off-delay type	2-wire	

* Lead wire length	
Blank	1 m (standard)
3	3 m (option)
5	5 m (option)

F Switch quantity	
R	One on rod end
H	One on head end
D	Two
T	Three

G Option		Max. ambient	Max. instantaneous
J	Bellows	100 °C	200 °C
L	Bellows	250 °C	400 °C
F	Push-in joint (straight)		
FE	Push-in joint (elbow)		
M	Piston rod material (stainless steel)		
V	Boss cut off		
P6	Copper and PTFE free		

H Accessory	
I	Rod eye
Y	Rod clevis (pin and washer split pin attached)
B2	Clevis bracket (pin and snap ring attached)

How to order switch

- Switch body + mounting bracket

CMK2 - **T0H** - **20**

Bore size (item ⑤ on previous page)

Switch model no. (item ④ on previous page)

- Only switch body

SW - **T0H**

Switch model no. (item ④ on previous page)

- Mounting bracket

CMK2 - **T** - **20**

Bore size (item ⑤ on previous page)

Bracket

How to order mounting bracket

Bore size (mm)	ϕ 20	ϕ 25	ϕ 32	ϕ 40
Mounting bracket				
Axial foot type (LB/LS)	M1-LB-20	M1-LB-30	M1-LB-30	M1-LB-30
Flange (FA/FB)	M1-FA-20	M1-FA-30	M1-FA-30	M1-FA-30
Trunnion (TA/TB)	M1-TA-20	M1-TA-30	M1-TA-30	M1-TA-40
Eye bracket type (CA)	M1-CA-20	M1-CA-30	M1-CA-30	M1-CA-30
Clevis bracket type (CB)	M1-CB-20	M1-CB-30	M1-CB-30	M1-CB-30

Note 1: Mounting nut/toothed washer are attached to each mounting bracket.

Note 2: Two sets of "M1-LB-*" in the above table are required for the axial direction foot (double-sided).

SCP*2
CMK2
CMA2
SCM
SCG
SCA2
SCS
CKV2
CA/OV2
SSD
CAT
MDC2
MVC
SMD2
MSD*
FC*
STK
ULK*
JSK/M2
JSG
JSC3
USSD
USC
JSB3
LMB
STG
STS/L
LCS
LCG
LCM
LCT
LCY
STR2
UCA2
HCM
HCA
SRL2
SRG
SRM
SRT
MRL2
MRG2
SM-25
CAC3
UCAC
RCC2
MFC
SHC
GLC
Ending

Medium bore size cylinder
Standard type

Internal structure and parts list

● CMK2-SR

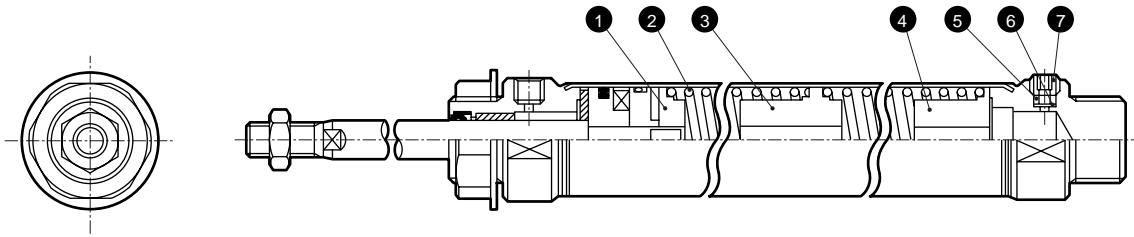

● Note: This caulking type cannot be disassembled.

No.	Parts name	Material	Remarks	No.	Parts name	Material	Remarks
1	Spring holder	Special aluminum		5	Element holder	Steel	Zinc chromate
2	Spring	Piano wire	Paint	6	Stainless steel wire net	Stainless steel	
3	Spring holder	Special aluminum		7	Bush	6 nylon	
4	Spring holder	Special aluminum					

Spring load

(Unit: N)

Bore size (mm)	Stroke length (mm)	Stroke length (mm)							
		25	50	75	100	150	200	250	300
φ 20	Stroke length 0 mm	11.9	11.8	11.8	11.8	11.8	11.8	11.8	11.8
	Full stroke length	31	38	31.5	38	38	38	38	38
φ 25	Stroke length 0 mm	12.1	12.5	12.5	12.5	12.5	12.5	12.5	12.5
	Full stroke length	30.4	40.2	33.1	40.2	40.2	40.2	40.2	40.2
φ 32	Stroke length 0 mm	24.5	24.3	24.5	24.3	24.3	24.3	24.3	24.3
	Full stroke length	52.9	54.9	54.9	54.9	54.9	54.9	54.9	54.9
φ 40	Stroke length 0 mm	28.4	28.4	28.4	28.4	28.4	28.4	28.4	28.4
	Full stroke length	78.4	100	82.3	100	100	100	100	100

Dimensions

- Single acting spring extend type

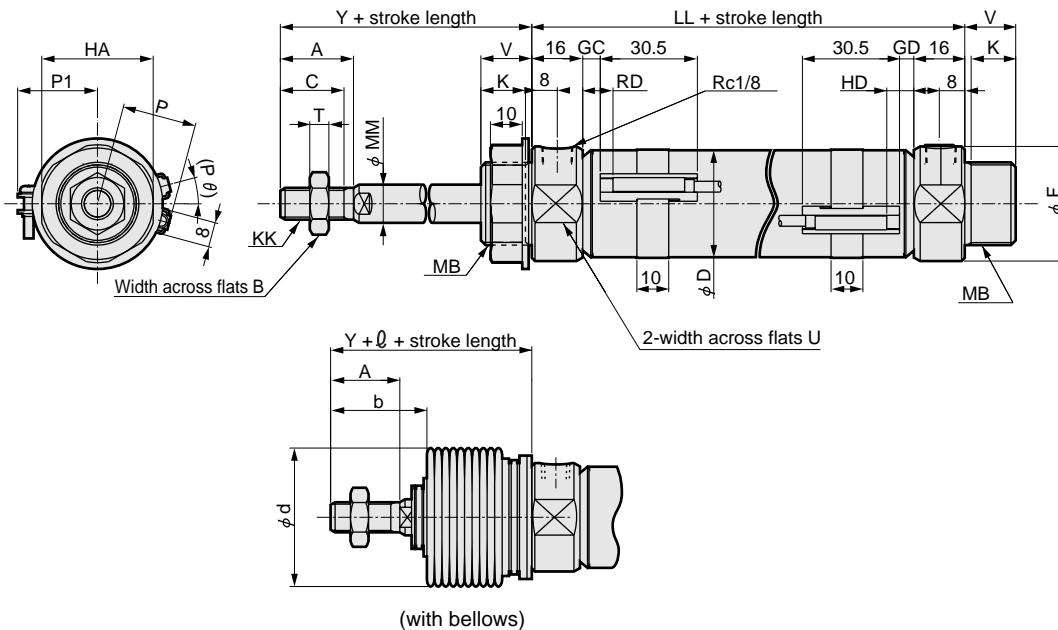

Note 1: Refer to page 188 for the HD, RD, and projecting dimensions of the T1* and T8* switches and 2-color indicator switch with preventive maintenance output.

RD: Rod side max. sensitive position

Note 2: For ℓ dimensions, round up decimal point or less.

HD: Head side max. sensitive position

Note 3: Refer to page 190 for dimensions of accessories.

Symbol	Basic type (00) basic dimensions																	
	A	B	C	D	F	HA	K	KK	LL						MB	MM	T	
Bore size (mm)									25 or less	25 to 50	50 to 100	100 to 150	150 to 200	200 to 250	250 to 300			
$\phi 20$	20	13	18	21.4	28	26	12	M8 x 1.0	91	93	120	147	174	201	228	M18 x 1.5	10	5
$\phi 25$	23	17	20	26.4	32	35	14	M10 x 1.25	94	99	129	159	189	219	249	M26 x 1.5	12	6
$\phi 32$	23	17	20	33.6	36	35	14	M10 x 1.25	94	99	129	159	189	219	249	M26 x 1.5	12	6
$\phi 40$	25	19	22	41.6	45	35	14	M12 x 1.5	98	103	133	163	193	223	253	M26 x 1.5	14	7

Symbol	With switch										With bellows								
	U	V	Y	GC	GD	Port size	RD	HD						P	P1	(P θ)°	b	d	
Bore size (mm)								25 or less	25 to 50	50 to 100	100 to 150	150 to 200	200 to 250	250 to 300					
$\phi 20$	24	14	44	4.0	3.0	20	8.0	32.0	34.0	61.0	88.0	115.0	142.0	169.0	17.3	19.5	22	30	30
$\phi 25$	30	16	46	5.5	4.5	25	9.5	33.5	38.5	68.5	98.5	128.5	158.5	188.5	19.8	22.0	18	32	46
$\phi 32$	34	16	46	5.5	4.5	32	9.5	33.5	38.5	68.5	98.5	128.5	158.5	188.5	24.3	25.5	15	32	46
$\phi 40$	43	16	48	7.0	6.5	40	11.5	35.5	40.5	70.5	100.5	130.5	160.5	190.5	28.3	29.5	12	34	46

Symbol	ℓ
Bore size (mm)	
$\phi 20$	(stroke length/3) + 6
$\phi 25$	(stroke length/3.25) + 7
$\phi 32$	(stroke length/3.25) + 7
$\phi 40$	(stroke length/3.25) + 7

Dimensions of each mounting type are same as standard type. Refer to pages 96 to 101.

SCP*2
CMK2
 CMA2
 SCM
 SCG
 SCA2
 SCS
 CKV2
 CA/OV2
 SSD
 CAT
 MDC2
 MVC
 SMD2
 MSD*
 FC*
 STK
 ULK*
 JSK/M2
 JSG
 JSC3
 USSD
 USC
 JSB3
 LMB
 STG
 STS/L
 LCS
 LCG
 LCM
 LCT
 LCY
 STR2
 UCA2
 HCM
 HCA
 SRL2
 SRG
 SRM
 SRT
 MRL2
 MRG2
 SM-25
 CAC3
 UCAC
 RCC2
 MFC
 SHC
 GLC
 Ending

Medium bore size cylinder
 Standard type

SCP*2
CMK2
 CMA2
 SCM
 SCG
 SCA2
 SCS
 CKV2
 CA/OV2
 SSD
 CAT
 MDC2
 MVC
 SMD2
 MSD*
 FC*
 STK
 ULK*
 JSK/M2
 JSG
 JSC3
 USSD
 USC
 JSB3
 LMB
 STG
 STS/L
 LCS
 LCG
 LCM
 LCT
 LCY
 STR2
 UCA2
 HCM
 HCA
 SRL2
 SRG
 SRM
 SRT
 MRL2
 MRG2
 SM-25
 CAC3
 UCAC
 RCC2
 MFC
 SHC
 GLC
 Ending

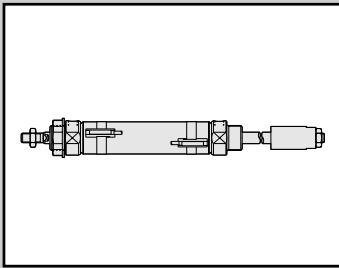

Medium bore size cylinder
 Double acting stroke adjustable type (extended)

CMK2-P Series

● Bore size: $\phi 20$, $\phi 25$, $\phi 32$, $\phi 40$

JIS symbol ● Double acting stroke adjustable type

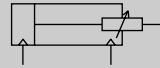

Specifications

Descriptions		CMK2-P			
Bore size mm	mm	$\phi 20$	$\phi 25$	$\phi 32$	$\phi 40$
Actuation		Double acting stroke adjustable type (extended)			
Working fluid		Compressed air			
Max. working pressure	MPa	1.0			
Min. working pressure	MPa	0.15			
Withstanding pressure	MPa	1.6			
Ambient temperature	°C	-10 to 60 (no freezing)			
Port size		Rc1/8			
Stroke tolerance	mm	$^{+2.0}_0$ (up to 200), $^{+2.4}_0$ (over 200)			
Working piston speed	mm/s	50 to 500			
Cushion		Rubber cushion			
Lubrication		Not required (when lubricating, use turbine oil Class 1 ISO VG32.)			
Adjustable stroke range	mm	Max. 50			
Allowable energy absorption	J	0.166	0.308	0.424	0.639

Stroke length

Bore size (mm)	Standard stroke length (mm)	Max. stroke length (mm)	Min. stroke length (mm)
$\phi 20$	25, 50, 75, 100, 150,	450	25
$\phi 25$			
$\phi 32$			
$\phi 40$	200, 250, 300	430	
		400	

Note 1: Custom stroke length is available per 1 mm increment.
 Note 2: For single foot type (LS type), maximum stroke length is 50 mm.
 Note 3: For bellows "J" type, stroke length should be longer than 25 mm.
 Consult with CKD when stroke length is shorter than 25 mm.

Min. stroke length of type with switch

(Unit: mm)

Switch quantity	1				2				3			
	Proximity		Reed		Proximity		Reed		Proximity		Reed	
	T2, T3	T1, T*Y*	T0, T5	T8	T2, T3	T1, T*Y*	T0, T5	T8	T2, T3	T1, T*Y*	T0, T5	T8
Bore size (mm)												
$\phi 20$	10				25	35	25	35	50	55	50	55
$\phi 25$	10				25	35	25	35	50	55	50	55
$\phi 32$	10				25	35	25	35	50	55	50	55
$\phi 40$	10				25	35	25	35	50	55	50	55

Note 1: Up to three switches can be mounted.

- SCP*2
- CMK2**
- CMA2
- SCM
- SCG
- SCA2
- SCS
- CKV2
- CA/OV2
- SSD
- CAT
- MDC2
- MVC
- SMD2
- MSD*
- FC*
- STK
- ULK*
- JSK/M2
- JSG
- JSC3
- USSD
- USC
- JSB3
- LMB
- STG
- STS/L
- LCS
- LCG
- LCM
- LCT
- LCY
- STR2
- UCA2
- HCM
- HCA
- SRL2
- SRG
- SRM
- SRT
- MRL2
- MRG2
- SM-25
- CAC3
- UCAC
- RCC2
- MFC
- SHC
- GLC
- Ending

Switch specifications

● 1 color/2 color indicator

* The T0/T5 switch can be used with 220 VAC. Contact CKD for working conditions.

Descriptions	Proximity 2-wire			Proximity 3-wire			Reed 2-wire						
	T1H/T1V	T2H/T2V/ T2JH/T2JV	T2YH/T2YV	T3H/T3V	T3PH/T3PV (Custom order)	T3YH/T3YV	TOH/TOV	T5H/T5V			T8H/T8V		
Applications	Programmable controller Relay, small solenoid valve		Programmable controller dedicated	Programmable controller, relay			Programmable controller, relay	Programmable controller, relay, IC circuit (w/o light), serial connection			Programmable controller, relay		
Output method	-			NPN output	PNP output	NPN output	-						
Power voltage	-			10 to 28 VDC			-						
Load voltage	85 to 265 VAC		10 to 30 VDC	30 VDC or less			12/24 VDC	110 VAC	5/12/24 VDC	110 VAC	12/24 VDC	110 VAC	220 VAC
Load current	5 to 100 mA		5 to 20 mA (Note 1)	100 mA or less		50 mA or less	5 to 50 mA	7 to 20 mA	50 mA or less	20 mA or less	5 to 50 mA	7 to 20 mA	7 to 10 mA
Light	LED (ON lighting)		LED (ON lighting)	Red/green LED (ON lighting)	LED (ON lighting)	Green LED (ON lighting)	Red/Green LED (ON lighting)	LED (ON lighting)		Without indicator light			LED (ON lighting)
Leakage current	1 mA or less with 100 VAC 2 mA or less with 200 VAC		1 mA or less	10 μA or less			0 mA						

● With preventive maintenance output

Descriptions	Proximity 3-wire		Proximity 4-wire		Proximity 3-wire		Proximity 4-wire	
	T2YFH/V		T3YFH/V		T2YMH/V		T3YMH/V	
Applications	Programmable controller dedicated		Programmable controller, relay		Programmable controller dedicated		Programmable controller, relay	
Output method	NPN output							
Light	Red/Green LED (ON lighting)							
	Installation position adjustment		-		Yellow LED (ON lighting)			
Regular Output section	Power voltage		10 to 28 VDC		-		10 to 28 VDC	
	Load voltage		30 VDC or less		10 to 30 VDC		30 VDC or less	
	Load current		50 mA or less		5 to 20 mA		50 mA or less	
	Leakage current		10 μA or less		1.2 mA or less		10 μA or less	
Preventive maintenance Output section	30 VDC or less							
	Load current		50 mA or less		5 to 20 mA or less		50 mA or less	
	10 μA or less							

Note 1: Refer to Ending 1 for other switches.

Note 2: The above maximum load current of 20 mA applies at 25 °C. If the switch's working ambient temperature exceeds 25 °C, the load current will be lower than 20 mA. (5 to 10 mA when 60 °C)

Cylinder weight

(Unit: kg)

Descriptions/mounting style	Adjustable stroke length	Product weight when stroke length (S) = 0 mm					Switch weight	Switch rail + band weight	Additional weight per S = 10 mm
		Basic (00)	Axial foot (LB)	Axial foot (LS)	Flange (FA/FB)	Trunnion (TA/TB)	Grommet		
φ 20	25	0.23	0.38	0.31	0.29	0.28	0.018	0.005	0.01
	50	0.26	0.41	0.34	0.32	0.31			
φ 25	25	0.41	0.67	0.54	0.56	0.51	0.018	0.005	0.01
	50	0.49	0.75	0.62	0.64	0.59			
φ 32	25	0.45	0.71	0.58	0.60	0.55	0.018	0.009	0.02
	50	0.52	0.78	0.65	0.67	0.62			
φ 40	25	0.63	0.89	0.76	0.78	0.79	0.018	0.009	0.02
	50	0.71	0.97	0.84	0.86	0.87			

(E.g.) Product weight of
CMK2-P-FA-32-50-25T0H-D

When S = 0 mm, product weight is 0.60 kg
 Additional weight at S = 50 mm is additional weight at S = 10 mm $0.02 \times \frac{\text{Product stroke length (50)}}{10} = 0.10$ kg
 Weight of two switches is 0.036 kg
 Weight of switch rail and two bands is 0.018 kg
 Product weight is 0.60 kg + 0.1 kg + 0.036 kg + 0.018 kg = 0.754 kg

Medium bore size cylinder
Standard type

How to order

Without switch

CMK2-P - 00 - 20 - 100 - 25 - F - I

With switch

CMK2-P - 00 - 20 - 100 - 25 - T0H - D - F - I

A Mounting style
Note 1

B Bore size

C Port thread type

D Stroke length

E Adjustable stroke range

F Switch model no.

G Switch quantity
Note 9

H Option
Note 3, Note 4
Note 5

I Accessory
Note 6

Symbol	Descriptions
A Mounting style	
00	Basic type
LB	Axial foot type (both sides)
LS	Axial foot type (single)
FA	Rod side flange type
FB	Head side flange type
TA	Rod side trunnion type
TB	Head side trunnion type

B Bore size (mm)	
20	φ 20
25	φ 25
32	φ 32
40	φ 40

C Port thread type	
Blank	Rc thread
NN	NPT thread (custom order)
GN	G thread (custom order)

D Stroke length (mm)		
Bore size	Stroke length Note 2	Custom stroke length
φ 20	25 to 450	By 1 mm increment
φ 25	25 to 450	
φ 32	25 to 430	
φ 40	25 to 400	

E Adjustable stroke range (mm)	
25	25
50	50

F Switch model no.					
Lead wire Straight type	Lead wire L type	Contact	Indicator	Lead wire	
T0H*	T0V*	Reed	1 color	2-wire	
T5H*	T5V*		Without indicator light		
T8H*	T8V*		1 color		
T1H*	T1V*	Proximity	1 color	2-wire	
T2H*	T2V*			3-wire	
T3H*	T3V*				
T3PH*	T3PV*		1 color (custom order)	3-wire	
T2YH*	T2YV*		2 color	(w/o light for preventive maintenance output)	2-wire
T3YH*	T3YV*				3-wire
T2YMH*	T2YMV*		2 color	(Light available for preventive maintenance output (1 color))	3-wire
T3YMH*	T3YMV*	4 wire			
T2JH*	T2JV*	Off-delay type		2-wire	

* Lead wire length	
Blank	1 m (standard)
3	3 m (option)
5	5 m (option)

G Switch quantity	
R	One on rod end
H	One on head end
D	Two
T	Three

H Option			
		Max. ambient	Max. instantaneous
J	Bellows	100 °C	200 °C
L	Bellows	250 °C	400 °C
F	Push-in joint (straight)		
FE	Push-in joint (elbow)		
M	Piston rod material (stainless steel)		
P6	Copper and PTFE free		

I Accessory	
I	Rod eye
Y	Rod clevis (pin and washer split pin attached)
B2	Clevis bracket (pin and snap ring attached)

⚠ Note on model no. selection

Note 1: The maximum stroke of the single-end foot type (LS type) is 50 mm.

Note 2: Refer to page 114 for min. stroke length with switch.

Note 3: For bellows "J" type, stroke length should be longer than 25 mm. Consult with CKD when stroke length is shorter than 25 mm.

Note 4: Applicable tube O.D. of F; push-in joint (straight), FE; push-in joint (elbow) is φ 6.

Note 5: Instantaneous maximum temperature is the temperature when spark and spatter etc. instantaneously contacts to bellows.

Note 6: "I" and "Y" can not be selected at the same time.

Note 7: Refer to Ending 89 for the custom order specifications of rod end form.

Note 8: Refer to page 84 for variation and combinations of options.

Note 9: Up to three switches can be mounted. If more than four switches are required, switch mounting brackets for the extra switches must be prepared separately.

<Example of model number>

CMK2-P-LB-20-100-25-T0H-D-FI

Model: Medium bore size cylinder double acting stroke adjustment type (extended)

- A Mounting style : Axial foot type (both sides)
- B Bore size : φ 20 mm
- C Port thread type : Rc thread
- D Stroke length : 100 mm
- E Adjustable stroke length : 25 mm
- F Switch model no. : Reed T0H switch and lead wire 1 m
- G Switch quantity : Two
- H Option : Push-in joint (straight)
- I Accessory : Rod eye

How to order switch

● Switch body + mounting bracket

CMK2 - **T0H** - **20**

Bore size (item **B** on previous page)

Switch model no. (item **F** on previous page)

● Only switch body

SW - **T0H**

Switch model no. (item **F** on previous page)

● Mounting bracket

CMK2 - **T** - **20**

Bore size

(item **B** on previous page)
Bracket

How to order mounting bracket

Bore size (mm)	$\phi 20$	$\phi 25$	$\phi 32$	$\phi 40$
Mounting bracket				
Axial foot type (LB/LS)	M1-LB-20	M1-LB-30	M1-LB-30	M1-LB-30
Flange (FA/FB)	M1-FA-20	M1-FA-30	M1-FA-30	M1-FA-30
Trunnion (TA/TB)	M1-TA-20	M1-TA-30	M1-TA-30	M1-TA-40

Note 1: Mounting nut/toothed washer are attached to each mounting bracket.

Note 2: Two sets of "M1-LB-*" in the above table are required for the axial direction foot (double-sided).

SCP*2
CMK2
CMA2
SCM
SCG
SCA2
SCS
CKV2
CA/OV2
SSD
CAT
MDC2
MVC
SMD2
MSD*
FC*
STK
ULK*
JSK/M2
JSG
JSC3
USSD
USC
JSB3
LMB
STG
STS/L
LCS
LCG
LCM
LCT
LCY
STR2
UCA2
HCM
HCA
SRL2
SRG
SRM
SRT
MRL2
MRG2
SM-25
CAC3
UCAC
RCC2
MFC
SHC
GLC
Ending

Medium bore size cylinder
Standard type

Internal structure and parts list

- SCP*2
- CMK2**
- CMA2
- SCM
- SCG
- SCA2
- SCS
- CKV2
- CA/OV2
- SSD
- CAT
- MDC2
- MVC
- SMD2
- MSD*
- FC*
- STK
- ULK*
- JSK/M2
- JSG
- JSC3
- USSD
- USC
- JSB3
- LMB
- STG
- STS/L
- LCS
- LCG
- LCM
- LCT
- LCY
- STR2
- UCA2
- HCM
- HCA
- SRL2
- SRG
- SRM
- SRT
- MRL2
- MRG2
- SM-25
- CAC3
- UCAC
- RCC2
- MFC
- SHC
- GLC
- Ending

● CMK2-P

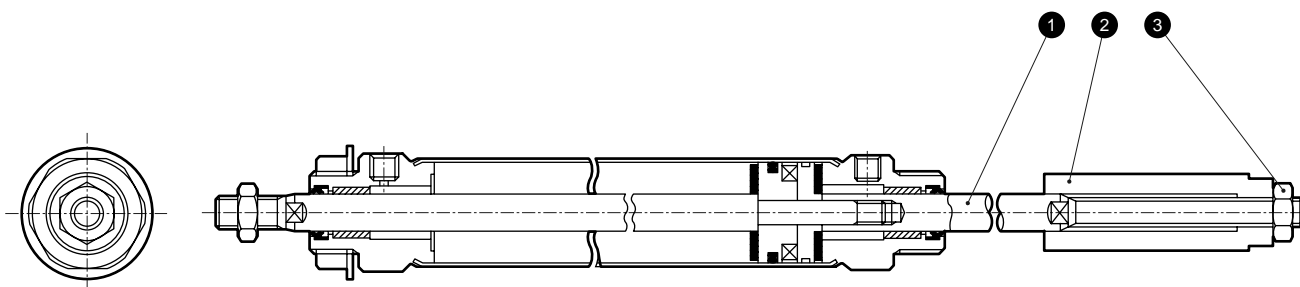

● Note: This caulking type cannot be disassembled.

No.	Parts name	Material	Remarks
1	Piston rod B	$\phi 20, \phi 25$: Stainless steel $\phi 32, \phi 40$: Carbon steel	Industrial chrome plating
2	Adjustable stopper	Steel	Zinc chromate
3	Lock nut	Steel	Zinc chromate

Dimensions

● Stroke adjustable type

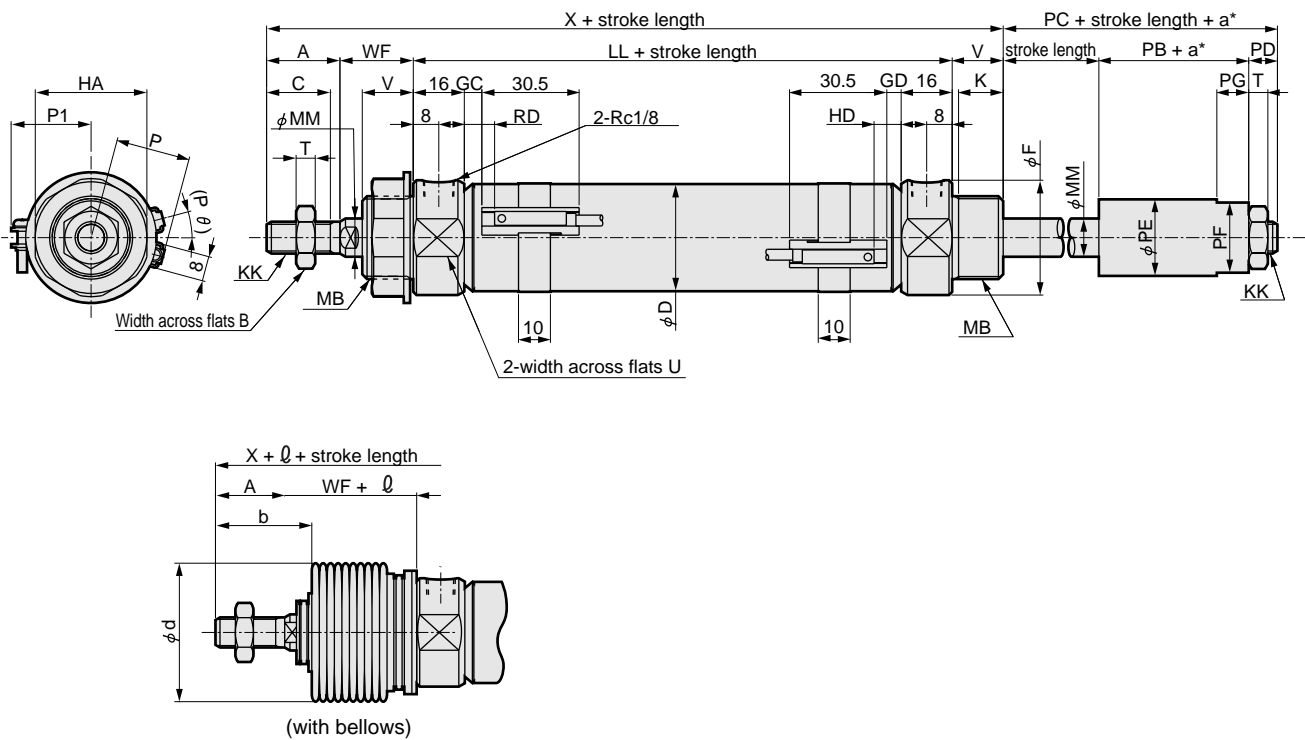

Note 1: Refer to page 188 for the HD, RD, and projecting dimensions of the T1* and T8* switches and 2-color indicator switch with preventive maintenance output.

RD: Rod side max. sensitive position
HD: Head side max. sensitive position

Note 2: For ℓ dimensions, round up decimal point or less.
Note 3: Refer to page 190 for dimensions of accessories.

a^* : adjustable stroke length.

Symbol	Basic type (00) basic dimensions															
Bore size (mm)	A	B	C	D	F	HA	K	KK	LL	MB	MM	T	U	V	WF	X
$\phi 20$	20	13	18	21.4	28	26	12	M8 x 1.0	66	M18 x 1.5	10	5	24	14	24	124
$\phi 25$	23	17	20	26.4	32	35	14	M10 x 1.25	69	M26 x 1.5	12	6	30	16	23	131
$\phi 32$	23	17	20	33.6	36	35	14	M10 x 1.25	69	M26 x 1.5	12	6	34	16	23	131
$\phi 40$	25	19	22	41.6	45	35	14	M12 x 1.5	73	M26 x 1.5	14	7	43	16	23	137
Symbol	With switch												With bellows			
Bore size (mm)	PB	PC	PD	PE	PF	PG	GC	GD	RD	HD	P	P1	(P θ)°	b	d	ℓ
$\phi 20$	21	29	8	16	14	7	4.0	3.0	8.0	7.0	17.3	19.5	22	30	30	(stroke length/3) + 6
$\phi 25$	22	31	9	24	22	10	5.5	4.5	9.5	8.5	19.8	22.0	18	32	46	(stroke length/3.25) + 7
$\phi 32$	22	31	9	24	22	10	5.5	4.5	9.5	8.5	24.3	25.5	15	32	46	(stroke length/3.25) + 7
$\phi 40$	22	32	10	24	22	10	7.0	6.5	11.5	10.5	28.3	29.5	12	34	46	(stroke length/3.25) + 7

Dimensions of each mounting type are same as standard type. Refer to pages 96 to 101.

SCP*2
CMK2
CMA2
SCM
SCG
SCA2
SCS
CKV2
CA/OV2
SSD
CAT
MDC2
MVC
SMD2
MSD*
FC*
STK
ULK*
JSK/M2
JSG
JSC3
USSD
USC
JSB3
LMB
STG
STS/L
LCS
LCG
LCM
LCT
LCY
STR2
UCA2
HCM
HCA
SRL2
SRG
SRM
SRT
MRL2
MRG2
SM-25
CAC3
UCAC
RCC2
MFC
SHC
GLC
Ending

Medium bore size cylinder
Standard type

SCP*2
CMK2
 CMA2
 SCM
 SCG
 SCA2
 SCS
 CKV2
 CA/OV2
 SSD
 CAT
 MDC2
 MVC
 SMD2
 MSD*
 FC*
 STK
 ULK*
 JSK/M2
 JSG
 JSC3
 USSD
 USC
 JSB3
 LMB
 STG
 STS/L
 LCS
 LCG
 LCM
 LCT
 LCY
 STR2
 UCA2
 HCM
 HCA
 SRL2
 SRG
 SRM
 SRT
 MRL2
 MRG2
 SM-25
 CAC3
 UCAC
 RCC2
 MFC
 SHC
 GLC
 Ending

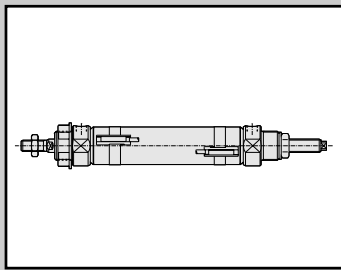

Medium bore size cylinder
 Double acting stroke adjustable type (retracted)

CMK2-R Series

● Bore size: $\phi 20$, $\phi 25$, $\phi 32$, $\phi 40$

JIS symbol ● Double acting stroke adjustable type

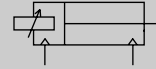

Specifications

Descriptions		CMK2-R			
Bore size	mm	$\phi 20$	$\phi 25$	$\phi 32$	$\phi 40$
Actuation		Double acting stroke adjustable type (retracted)			
Working fluid		Compressed air			
Max. working pressure	MPa	1.0			
Min. working pressure	MPa	0.1			
Withstanding pressure	MPa	1.6			
Ambient temperature	°C	-10 to 60 (no freezing)			
Port size		Rc1/8			
Stroke tolerance	mm	$^{+2.0}_0$ (up to 200), $^{+2.4}_0$ (over 200)			
Working piston speed	mm/s	50 to 500			
Cushion		Rubber cushion			
Lubrication		Not required (when lubricating, use turbine oil Class 1 ISO VG32.)			
Adjustable stroke range	mm	Max. 50			
Allowable energy absorption	J	0.166	0.308	0.424	0.639

Stroke length

Bore size (mm)	Standard stroke length (mm)	Max. stroke length (mm)	Min. stroke length (mm)
$\phi 20$	25, 50, 75, 100, 150, 200, 250, 300	750	25
$\phi 25$			
$\phi 32$			
$\phi 40$			

Note 1: Custom stroke length is available per 1 mm increment.
 Note 2: For single foot type (LS type), maximum stroke length is 50 mm.
 Note 3: For bellows "J" type, stroke length should be longer than 25 mm.
 Consult with CKD when stroke length is shorter than 25 mm.

Min. stroke length of type with switch

(Unit: mm)

Switch quantity	1				2				3											
	Proximity		Reed		Proximity		Reed		Proximity		Reed									
	T2, T3	T1, T*Y*	T0, T5	T8	T2, T3	T1, T*Y*	T0, T5	T8	T2, T3	T1, T*Y*	T0, T5	T8								
Bore size (mm)																				
$\phi 20$	10				25		35		25		35		50		55		50		55	
$\phi 25$	10				25		35		25		35		50		55		50		55	
$\phi 32$	10				25		35		25		35		50		55		50		55	
$\phi 40$	10				25		35		25		35		50		55		50		55	

Note 1: Up to three switches can be mounted.

- SCP*2
- CMK2**
- CMA2
- SCM
- SCG
- SCA2
- SCS
- CKV2
- CA/OV2
- SSD
- CAT
- MDC2
- MVC
- SMD2
- MSD*
- FC*
- STK
- ULK*
- JSK/M2
- JSG
- JSC3
- USSD
- USC
- JSB3
- LMB
- STG
- STS/L
- LCS
- LCG
- LCM
- LCT
- LCY
- STR2
- UCA2
- HCM
- HCA
- SRL2
- SRG
- SRM
- SRT
- MRL2
- MRG2
- SM-25
- CAC3
- UCAC
- RCC2
- MFC
- SHC
- GLC
- Ending

Switch specifications

● 1 color/2 color indicator

* The T0/T5 switch can be used with 220 VAC. Contact CKD for working conditions.

Descriptions	Proximity 2-wire			Proximity 3-wire			Reed 2-wire						
	T1H/T1V	T2H/T2V/ T2JH/T2JV	T2YH/T2YV	T3H/T3V	T3PH/T3PV (Custom order)	T3YH/T3YV	TOH/TOV	T5H/T5V			T8H/T8V		
Applications	Programmable controller Relay, small solenoid valve		Programmable controller dedicated	Programmable controller, relay			Programmable controller, relay	Programmable controller, relay, IC circuit (w/o light), serial connection			Programmable controller, relay		
Output method	-			NPN output	PNP output	NPN output	-						
Power voltage	-			10 to 28 VDC			-						
Load voltage	85 to 265 VAC		10 to 30 VDC	30 VDC or less			12/24 VDC	110 VAC	5/12/24 VDC	110 VAC	12/24 VDC	110 VAC	220 VAC
Load current	5 to 100 mA		5 to 20 mA (Note 1)	100 mA or less		50 mA or less	5 to 50 mA	7 to 20 mA	50 mA or less	20 mA or less	5 to 50 mA	7 to 20 mA	7 to 10 mA
Light	LED (ON lighting)		LED (ON lighting)	Red/green LED (ON lighting)	LED (ON lighting)	Green LED (ON lighting)	Red/Green LED (ON lighting)	LED (ON lighting)		Without indicator light			LED (ON lighting)
Leakage current	1 mA or less with 100 VAC 2 mA or less with 200 VAC		1 mA or less		10 μA or less			0 mA					

● With preventive maintenance output

Descriptions	Proximity 3-wire		Proximity 4-wire		Proximity 3-wire		Proximity 4-wire	
	T2YFH/V		T3YFH/V		T2YMH/V		T3YMH/V	
Applications	Programmable controller dedicated		Programmable controller, relay		Programmable controller dedicated		Programmable controller, relay	
Output method	NPN output							
Light	Red/Green LED (ON lighting)							
	Installation position adjustment		-		Yellow LED (ON lighting)			
Regular Output section	Power voltage		10 to 28 VDC		-		10 to 28 VDC	
	Load voltage		30 VDC or less		10 to 30 VDC		30 VDC or less	
	Load current		50 mA or less		5 to 20 mA		50 mA or less	
	Leakage current		10 μA or less		1.2 mA or less		10 μA or less	
Preventive maintenance Output section	30 VDC or less							
	Load voltage		50 mA or less		5 to 20 mA or less		50 mA or less	
	Load current		10 μA or less					

Note 1: Refer to Ending 1 for other switches.

Note 2: The above maximum load current of 20 mA applies at 25 °C. If the switch's working ambient temperature exceeds 25 °C, the load current will be lower than 20 mA. (5 to 10 mA when 60 °C)

Cylinder weight

(Unit: kg)

Descriptions/mounting style	Adjustable stroke length	Product weight when stroke length (S) = 0 mm					Switch weight	Switch rail + band weight	Additional weight per S = 10 mm
		Basic (00)	Axial foot (LB)	Axial foot (LS)	Flange (FA/FB)	Trunnion (TA/TB)	Grommet		
φ20	25	0.20	0.35	0.28	0.26	0.25	0.018	0.005	0.01
	50	0.20	0.35	0.28	0.26	0.25			
φ25	25	0.35	0.61	0.48	0.50	0.45	0.018	0.005	0.01
	50	0.37	0.63	0.50	0.52	0.47			
φ32	25	0.39	0.65	0.52	0.54	0.49	0.018	0.009	0.02
	50	0.41	0.67	0.54	0.56	0.51			
φ40	25	0.58	0.84	0.71	0.73	0.74	0.018	0.009	0.02
	50	0.60	0.86	0.73	0.75	0.76			

(E.g.) Product weight of
CMK2-R-FA-32-50-25T0H-D

When S = 0 mm, product weight is 0.54 kg

Additional weight at S = 50 mm is additional weight at S = 10 mm $0.02 \times \frac{\text{Product stroke length (50)}}{10} = 0.10$ kg

Weight of two switches is 0.036 kg

Weight of switch rail and two bands is 0.018 kg

Product weight is 0.54 kg + 0.1 kg + 0.036 kg + 0.018 kg = 0.694 kg

Medium bore size cylinder
Standard type

CMK2-R Series

How to order

Without switch

CMK2-R - 00 - 20 - 100 - 25 - L - I

With switch

CMK2-R - 00 - 20 - 100 - 25 - T0H - D - L - I

A Mounting style
Note 1

B Bore size

C Port thread type

D Stroke length

E Adjustable stroke range

F Switch model no.

Symbol	Descriptions
A Mounting style	
00	Basic type
LB	Axial foot type (both sides)
LS	Axial foot type (single)
FA	Rod side flange type
FB	Head side flange type
TA	Rod side trunnion type
TB	Head side trunnion type

B Bore size (mm)	
20	φ 20
25	φ 25
32	φ 32
40	φ 40

C Port thread type	
Blank	Rc thread
NN	NPT thread (custom order)
GN	G thread (custom order)

D Stroke length (mm)		
Bore size	Stroke length Note 2	Custom stroke length
φ 20	25 to 750	By 1 mm increment
φ 25	25 to 750	
φ 32	25 to 750	
φ 40	25 to 750	

E Adjustable stroke range (mm)	
25	25
50	50

F Switch model no.				
Lead wire Straight type	Lead wire L type	Contact	Indicator	Lead wire
			Reed	
T0H*	T0V*	Without indicator light		
T5H*	T5V*	1 color		
T8H*	T8V*	Proximity	1 color	2-wire
T1H*	T1V*			
T2H*	T2V*			3-wire
T3H*	T3V*			
T3PH*	T3PV*	1 color (custom order)	3-wire	
T2YH*	T2YV*	2 color (w/o light for preventive maintenance output)	2 color	2-wire
T3YH*	T3YV*			3-wire
T2YFH*	T2YFV*			4 wire
T2YMH*	T2YMV*	2 color (Light available for preventive maintenance output (1 color))	2 color	3-wire
T3YMH*	T3YMV*			4 wire
T2JH*	T2JV*	Off-delay type	2-wire	

* Lead wire length	
Blank	1 m (standard)
3	3 m (option)
5	5 m (option)

G Switch quantity	
R	One on rod end
H	One on head end
D	Two
T	Three

H Option			
		Max. ambient	Max. instantaneous
J	Bellows	100 °C	200 °C
L	Bellows	250 °C	400 °C
F	Push-in joint (straight)		
FE	Push-in joint (elbow)		
M	Piston rod material (stainless steel)		
P6	Copper and PTFE free		

I Accessory	
I	Rod eye
Y	Rod clevis (pin and washer split pin attached)
B2	Clevis bracket (pin and snap ring attached)

Note on model no. selection

Note 1: The maximum stroke of the single-end foot type (LS type) is 50 mm.

Note 2: Refer to page 120 for min. stroke length with switch.

Note 3: The maximum ambient temperature of the bellows for sizes φ25 to φ40 is 100 °C (symbol J).

Note 4: For bellows "J" type, stroke length should be more than 25 mm. Consult with CKD when stroke length is shorter than 25 mm.

Note 5: Applicable tube O.D. of F; push-in joint (straight), FE; push-in joint (elbow) is φ 6.

Note 6: Instantaneous maximum temperature is the temperature when spark and spatter etc. instantaneously contacts to bellows.

Note 7: "I" and "Y" can not be selected at the same time.

Note 8: Refer to Ending 89 for custom specifications of rod end form.

Note 9: Refer to page 84 for variation and combinations of options.

Note 10: Up to three switches can be mounted. If more than four switches are required, switch mounting brackets for the extra switches must be prepared separately.

<Example of model number>

CMK2-R-00-20-100-25-T0H-D-MI

Model: Medium bore size cylinder, double acting stroke adjustment type (retracted)

- A Mounting style : Basic type
- B Bore size : φ 20 mm
- C Port thread type : Rc thread
- D Stroke length : 100 mm
- E Adjustable stroke length : 25 mm
- F Switch model no. : Reed T0H switch and lead wire 1 m
- G Switch quantity : Two
- H Option : Piston rod material change
- I Accessory : Rod eye

G Switch quantity
Note 10

H Option
Note 3, Note 4,
Note 5, Note 6

I Accessory
Note 7

How to order switch

- Switch body + mounting bracket

CMK2 - **T0H** - **20**

Switch model no. (item ① on previous page)

Bore size (item ② on previous page)

- Only switch body

SW - **T0H**

Switch model no. (item ① on previous page)

- Mounting bracket

CMK2 - **T** - **20**

Bracket
Bore size (item ② on previous page)

How to order mounting bracket

Bore size (mm)	φ20	φ25	φ32	φ40
Mounting bracket				
Axial foot type (LB/LS)	M1-LB-20	M1-LB-30	M1-LB-30	M1-LB-30
Flange (FA/FB)	M1-FA-20	M1-FA-30	M1-FA-30	M1-FA-30
Trunnion (TA/TB)	M1-TA-20	M1-TA-30	M1-TA-30	M1-TA-40

Note 1: Mounting nut/toothed washer are attached to each mounting bracket.

Note 2: Two sets of "M1-LB-*" in the above table are required for the axial direction foot (double-sided).

SCP*2
CMK2
CMA2
SCM
SCG
SCA2
SCS
CKV2
CA/OV2
SSD
CAT
MDC2
MVC
SMD2
MSD*
FC*
STK
ULK*
JSK/M2
JSG
JSC3
USSD
USC
JSB3
LMB
STG
STS/L
LCS
LCG
LCM
LCT
LCY
STR2
UCA2
HCM
HCA
SRL2
SRG
SRM
SRT
MRL2
MRG2
SM-25
CAC3
UCAC
RCC2
MFC
SHC
GLC
Ending

Medium bore size cylinder
Standard type

CMK2-R Series

Internal structure and parts list

- SCP*2
- CMK2**
- CMA2
- SCM
- SCG
- SCA2
- SCS
- CKV2
- CA/OV2
- SSD
- CAT
- MDC2
- MVC
- SMD2
- MSD*
- FC*
- STK
- ULK*
- JSK/M2
- JSG
- JSC3
- USSD
- USC
- JSB3
- LMB
- STG
- STS/L
- LCS
- LCG
- LCM
- LCT
- LCY
- STR2
- UCA2
- HCM
- HCA
- SRL2
- SRG
- SRM
- SRT
- MRL2
- MRG2
- SM-25
- CAC3
- UCAC
- RCC2
- MFC
- SHC
- GLC
- Ending

● CMK2-R

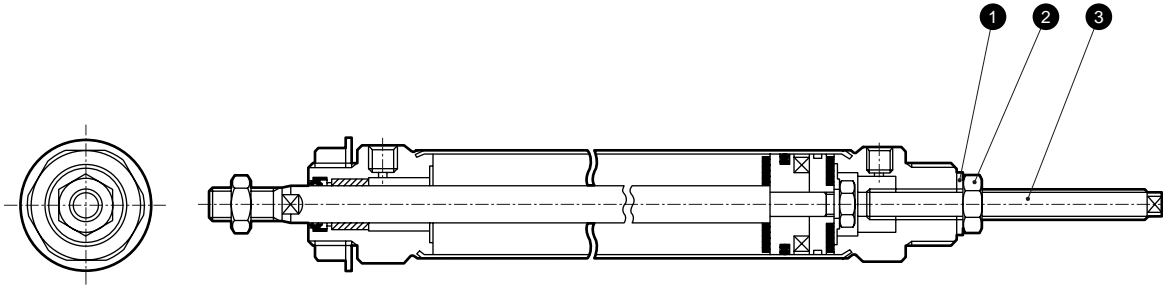

● Note: This caulking type cannot be disassembled.

No.	Parts name	Material	Remarks
1	Seal washer	Nitrile rubber and steel	
2	Lock nut	Steel	Zinc chromate
3	Adjusting bolt	Steel	Zinc chromate

Dimensions

● Stroke adjustable type (retracted)

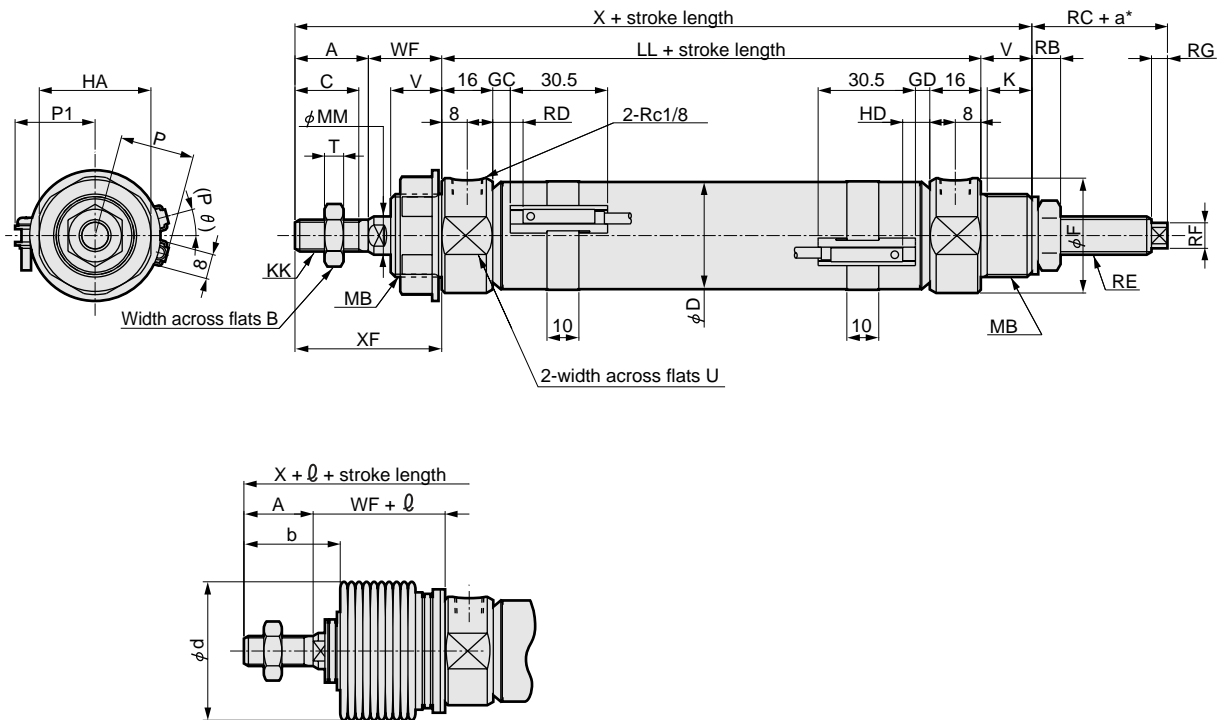

RD: Rod side max. sensitive position
HD: Head side max. sensitive position

Note 1: For l dimensions, round up decimal point or less. a^* : adjustable stroke length.
Note 2: Refer to page 190 for dimensions of accessories.

Symbol	Basic type (00) basic dimensions																
Bore size (mm)	A	B	C	D	F	HA	K	KK	LL	MB	MM	T	U	V	WF	X	XF
$\phi 20$	20	13	18	21.4	28	26	12	M8 x 1.0	66	M18 x 1.5	10	5	24	14	24	124	44
$\phi 25$	23	17	20	26.4	32	35	14	M10 x 1.25	69	M26 x 1.5	12	6	30	16	23	131	46
$\phi 32$	23	17	20	33.6	36	35	14	M10 x 1.25	69	M26 x 1.5	12	6	34	16	23	131	46
$\phi 40$	25	19	22	41.6	45	35	14	M12 x 1.5	73	M26 x 1.5	14	7	43	16	23	137	48
Symbol	With switch											With bellows					
Bore size (mm)	RB	RC	RE	RF	RG	GC	GD	RD	HD	P	P1	(P θ)°	b	d	l		
$\phi 20$	6.3	11	M8 x 1.0	*5.5	3	4.0	3.0	8.0	7.0	17.3	19.5	22	30	30	(stroke length/3) + 6		
$\phi 25$	9	17.5	M12 x 1.5	*8	5	5.5	4.5	9.5	8.5	19.8	22.0	18	32	46	(stroke length/3.25) + 7		
$\phi 32$	9	17.5	M12 x 1.5	*8	5	5.5	4.5	9.5	8.5	24.3	25.5	15	32	46	(stroke length/3.25) + 7		
$\phi 40$	9	16	M12 x 1.5	*8	5	7.0	6.5	11.5	10.5	28.3	29.5	12	34	46	(stroke length/3.25) + 7		

Dimensions of each mounting type are same as standard type. Refer to pages 96 to 101.

SCP*2
CMK2
CMA2
SCM
SCG
SCA2
SCS
CKV2
CA/OV2
SSD
CAT
MDC2
MVC
SMD2
MSD*
FC*
STK
ULK*
JSK/M2
JSG
JSC3
USSD
USC
JSB3
LMB
STG
STS/L
LCS
LCG
LCM
LCT
LCY
STR2
UCA2
HCM
HCA
SRL2
SRG
SRM
SRT
MRL2
MRG2
SM-25
CAC3
UCAC
RCC2
MFC
SHC
GLC
Ending

Medium bore size cylinder
Standard type



Medium bore size cylinder
Double acting heat resistance type

CMK2-T Series

● Bore size: $\phi 20$, $\phi 25$, $\phi 32$, $\phi 40$

JIS symbol ● Double acting cylinder single rod type

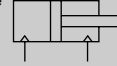

Specifications

Descriptions		CMK2-T			
Bore size	mm	$\phi 20$	$\phi 25$	$\phi 32$	$\phi 40$
Actuation		Double acting heat resistance type			
Working fluid		Compressed air			
Max. working pressure	MPa	1.0			
Min. working pressure	MPa	0.1			
Withstanding pressure	MPa	1.6			
Ambient temperature	°C	5 to 120			
Port size		Rc1/8			
Stroke tolerance	mm	$^{+2.0}_0$ (up to 200), $^{+2.4}_0$ (over 200)			
Working piston speed	mm/s	50 to 500			
Cushion		Rubber cushion			
Lubrication		Not available			
Allowable energy absorption	J	0.166	0.308	0.424	0.639

Stroke length

Bore size (mm)	Standard stroke length (mm)	Max. stroke length (mm)	Min. stroke length (mm)
$\phi 20$	25, 50, 75, 100, 150, 200, 250, 300	750	5
$\phi 25$			
$\phi 32$			
$\phi 40$			

Note 1: Custom stroke length is available per 1 mm increment.

Note 2: For single foot type (LS type), maximum stroke length is 50 mm.

Note 3: For bellows "J" type, stroke length should be longer than 25 mm.

Consult with CKD when stroke length is less than 25 mm.

Cylinder weight

(Unit: kg)

Descriptions/mounting style	Product weight when stroke length (S) = 0 mm								Additional weight per S = 10 mm
	Basic (00)	Axial foot (LB)	Axial foot (LS)	Flange (FA/FB)	Eye bracket (CA)	Clevis (CC)	Clevis bracket (CB)	Trunnion (TA/TB)	
$\phi 20$	0.17	0.32	0.25	0.23	0.32	0.18	0.32	0.22	0.01
$\phi 25$	0.26	0.52	0.39	0.41	0.50	0.26	0.50	0.36	0.01
$\phi 32$	0.29	0.55	0.42	0.44	0.53	0.29	0.53	0.39	0.02
$\phi 40$	0.47	0.73	0.60	0.62	0.71	0.49	0.71	0.63	0.02

(E.g.) Product weight of
CMK2-T-FA-32-50-T0H-D

When S = 0 mm, product weight is 0.44 kg

Additional weight at S = 50 mm is additional weight at S = 10 mm $0.02 \times \frac{\text{Product stroke length (50)}}{10} = 0.10$ kg

Product weight is 0.44 kg + 0.1 kg = 0.54 kg

How to order

CMK2-T - 00 - 20 - 100 - V I

A Mounting style
Note 1

B Bore size

C Port thread type

D Stroke length

E Option
Note 2, Note 3

F Accessory
Note 4

Symbol	Descriptions
A Mounting style	
00	Basic type
LB	Axial foot type (both sides)
LS	Axial foot type (single)
FA	Rod side flange type
FB	Head side flange type
CA	Eye bracket type
CC	Fixed eye
CC1	Eye and bush press fitted type
CB	Clevis bracket type (pin and washer split pin attached)
TA	Rod side trunnion type
TB	Head side trunnion type

B Bore size (mm)	
20	φ 20
25	φ 25
32	φ 32
40	φ 40

C Port thread type	
Blank	Rc thread
NN	NPT thread (custom order)
GN	G thread (custom order)

D Stroke length (mm)		
Bore size	Stroke length	Custom stroke length
φ 20	5 to 750	By 1 mm increment
φ 25	5 to 750	
φ 32	5 to 750	
φ 40	5 to 750	

E Option			
		Max. ambient	Max. instantaneous
L	Bellows	250°C	400°C
M	Piston rod material (stainless steel)		
V	Boss cut off		

F Accessory	
I	Rod eye
Y	Rod clevis (pin and washer split pin attached)
B2	Clevis bracket (pin and snap ring attached)

⚠ Note on model no. selection

Note 1: The maximum stroke of the single-end foot type (LS type) is 50 mm.

Note 2: For bellows "J" type, stroke length should be longer than 25 mm. Consult with CKD when stroke length is shorter than 25 mm.

Note 3: Instantaneous maximum temperature is the temperature when spark and spatter etc. instantaneously contacts to bellows.

Note 4: "I" and "Y" can not be selected at the same time.

Note 5: Refer to Ending 89 for the custom order specifications of rod end form.

Note 6: Refer to page 84 for variation and combinations of options.

<Example of model number>

CMK2-T-00-20-100-VI

Model: Medium bore size cylinder double acting heat resistance type

- A** Mounting style : Basic type
- B** Bore size : φ 20 mm
- C** Port thread type : Rc thread
- D** Stroke length : 100 mm
- E** Option : Boss cut off
- F** Accessory : Rod eye

SCP*2
CMK2
CMA2
SCM
SCG
SCA2
SCS
CKV2
CA/OV2
SSD
CAT
MDC2
MVC
SMD2
MSD*
FC*
STK
ULK*
JSK/M2
JSG
JSC3
USSD
USC
JSB3
LMB
STG
STS/L
LCS
LCG
LCM
LCT
LCY
STR2
UCA2
HCM
HCA
SRL2
SRG
SRM
SRT
MRL2
MRG2
SM-25
CAC3
UCAC
RCC2
MFC
SHC
GLC
Ending

Medium bore size cylinder
Standard type

Internal structure and parts list

- SCP*2
- CMK2**
- CMA2
- SCM
- SCG
- SCA2
- SCS
- CKV2
- CA/OV2
- SSD
- CAT
- MDC2
- MVC
- SMD2
- MSD*
- FC*
- STK
- ULK*
- JSK/M2
- JSG
- JSC3
- USSD
- USC
- JSB3
- LMB
- STG
- STS/L
- LCS
- LCG
- LCM
- LCT
- LCY
- STR2
- UCA2
- HCM
- HCA
- SRL2
- SRG
- SRM
- SRT
- MRL2
- MRG2
- SM-25
- CAC3
- UCAC
- RCC2
- MFC
- SHC
- GLC
- Ending

● CMK2-T

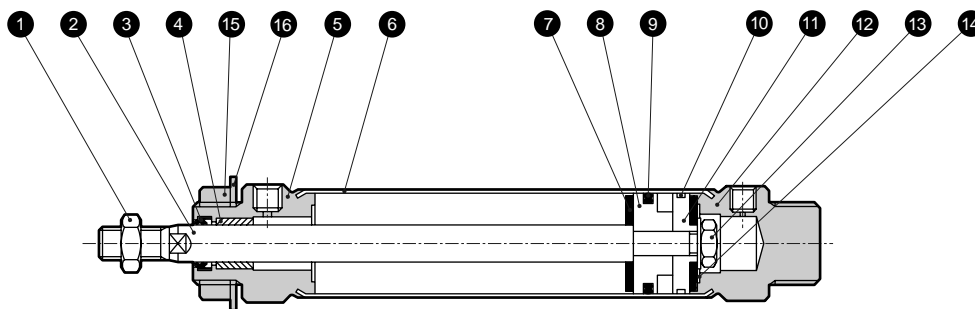

● Note: This caulking type cannot be disassembled.

No.	Parts name	Material	Remarks	No.	Parts name	Material	Remarks
1	Rod nut	Steel	Zinc chromate	8	Piston A	Aluminum alloy	
2	Piston rod	$\phi 20, \phi 25$: Stainless steel $\phi 32, \phi 40$: Carbon steel	Industrial chrome plating	9	Piston packing seal	Fluoro rubber	
3	Rod packing seal	Fluoro rubber		10	Wear ring	Special plastic	
4	Bush	$\phi 20$: Dry bearing $\phi 25, \phi 32, \phi 40$: Copper		11	Piston B	Aluminum alloy	
5	Rod cover	Aluminum alloy		12	Head cover	Aluminum alloy	
6	Cylinder tube	Stainless steel		13	Hexagon nut	Steel	Zinc chromate
7	Cushion rubber	Fluoro rubber		14	Spacer	Steel	Zinc chromate
				15	Nut	Steel	Zinc chromate
				16	The toothed washer	Steel	Zinc chromate

Dimensions

This is the same as the standard type. Refer to pages 95 to 101.

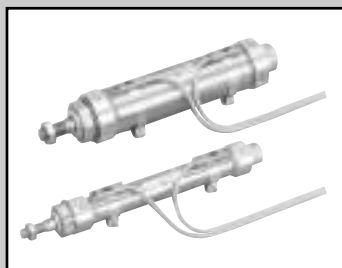

Medium bore size cylinder
Double acting rubber-air cushioned

CMK2-*C Series

- Bore size: $\phi 20$, $\phi 25$, $\phi 32$, $\phi 40$
- Port size: Rc1/8

JIS symbol ● Double acting cylinder single rod type

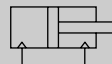

Specifications

Descriptions	CMK2			
Bore size	$\phi 20$	$\phi 25$	$\phi 32$	$\phi 40$
Actuation	Double acting			
Working fluid	Compressed air			
Max. working pressure MPa	1.0			
Min. working pressure MPa	0.2			
Withstanding pressure MPa	1.6			
Ambient temperature $^{\circ}\text{C}$	-10 to 60 (no freezing)			
Port size	Rc1/8			
Stroke tolerance mm	$^{+2.0}_0$ (up to 200), $^{+2.4}_0$ (over 200)			
Working piston speed mm/s	50 to 500 (use within absorbed energy range.)			
Cushion	Rubber-air cushion			
Lubrication	Not required (when lubricating, use turbine oil Class 1 ISO VG32.)			
Allowable energy absorption J	0.089	0.137	0.179	0.278

Stroke length

Bore size (mm)	Standard stroke length (mm)	Max. stroke length (mm)	Min. stroke length (mm)
$\phi 20$	25, 50, 75, 100, 150, 200, 250, 300	750	5
$\phi 25$			
$\phi 32$			
$\phi 40$			

Note 1: Custom stroke length is available per 1 mm increment.

Note 2: For single foot type (LS type), maximum stroke length is 50 mm.

Min. stroke length with switch

(Unit: mm)

Switch quantity	1				2				3			
	Proximity		Reed		Proximity		Reed		Proximity		Reed	
Bore size (mm)	T2, T3	T1, T*Y*	T0, T5	T8	T2, T3	T1, T*Y*	T0, T5	T8	T2, T3	T1, T*Y*	T0, T5	T8
$\phi 20$	10				25	35	25	35	50	55	50	55
$\phi 25$	10				25	35	25	35	50	55	50	55
$\phi 32$	10				25	35	25	35	50	55	50	55
$\phi 40$	10				25	35	25	35	50	55	50	55

Note 1: Up to three switches can be mounted.

Rubber-air cushion mechanism

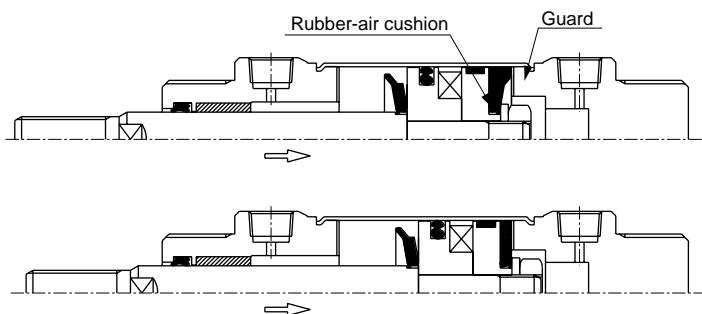

Explanation at Pull state

When the piston moves and the rubber-air cushion and cover contact, a sealed air space is formed in the shaded section. The air in the shaded section is compressed as the piston moves, and energy is absorbed. Energy absorbed by the rubber air cushion's compression strain is also calculated at the stroke end.

Colliding noise level decrease (example)

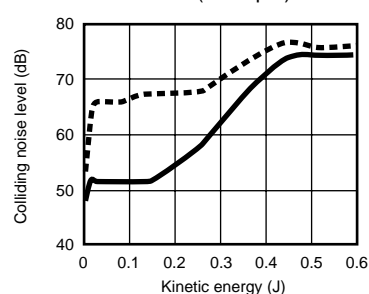

Colliding acceleration decrease (example)

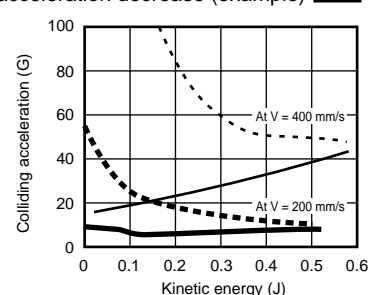

- SCP*2
- CMK2**
- CMA2
- SCM
- SCG
- SCA2
- SCS
- CKV2
- CA/OV2
- SSD
- CAT
- MDC2
- MVC
- SMD2
- MSD*
- FC*
- STK
- ULK*
- JSK/M2
- JSG
- JSC3
- USSD
- USC
- JSB3
- LMB
- STG
- STS/L
- LCS
- LCG
- LCM
- LCT
- LCY
- STR2
- UCA2
- HCM
- HCA
- SRL2
- SRG
- SRM
- SRT
- MRL2
- MRG2
- SM-25
- CAC3
- UCAC
- RCC2
- MFC
- SHC
- GLC

Switch specifications

1 color/2 color indicator

* T0/T5 switch can be used with 220 VAC. Consult with CKD for working conditions.

Descriptions	Proximity 2-wire			Proximity 3-wire			Reed 2-wire						
	T1H, T1V	T2H, T2V, T2JH, T2JV	T2YH, T2YV	T3H, T3V	T3PH, T3PV (Custom order)	T3YH, T3YV	T0H, T0V		T5H, T5V		T8H, T8V		
Applications	Programmable controller relay, small solenoid valve		Programmable controller dedicated	Programmable controller, relay			Programmable controller, relay		Programmable controller, relay, IC circuit (w/o light), serial connection		Programmable controller, relay		
Output method	-			NPN output	PNP output	NPN output	-						
Power voltage	-			10 to 28 VDC			-						
Load voltage	85 to 265 VAC		10 to 30 VDC	30 VDC or less			12/24 VDC	110 VAC	5/12/24 VDC	110 VAC	12/24 VDC	110 VAC	220 VAC
Load current	5 to 100 mA		5 to 20 mA (Note 1)	100 mA or less		50 mA or less	5 to 50 mA	7 to 20 mA	50 mA or less	20 mA or less	5 to 50 mA	7 to 20 mA	7 to 10 mA
Light	LED (ON lighting)		LED (ON lighting)	Red/green LED (ON lighting)	LED (ON lighting)	Green LED (ON lighting)	Red/green LED (ON lighting)	LED (ON lighting)		Without indicator light		LED (ON lighting)	
Leakage current	1 mA or less with 100 VAC 2 mA or less with 200 VAC		1 mA or less	10 μA or less			0 mA						

● With preventive maintenance output

Descriptions	Proximity 3-wire		Proximity 4-wire		Proximity 3-wire		Proximity 4-wire	
	T2YFH/V		T3YFH/V		T2YMH/V		T3YMH/V	
Applications	Programmable controller dedicated		Programmable controller, relay		Programmable controller dedicated		Programmable controller, relay	
Output method	NPN output							
Light	Red/green LED (ON lighting)							
	Installation position adjustment		-		Yellow LED (ON lighting)			
Regular Output section	Power voltage		10 to 28 VDC		-		10 to 28 VDC	
	Load voltage		30 VDC or less		10 to 30 VDC		30 VDC or less	
	Load current		50 mA or less		5 to 20 mA		50 mA or less	
	Leakage current		10 μA or less		1.2 mA or less		10 μA or less	
Preventive maintenance Output section	30 VDC or less							
	Load current		50 mA or less		5 to 20 mA or less		50 mA or less	
	10 μA or less							

Note 1: Refer to Ending 1 for other switches.

Note 2: The above maximum load current of 20 mA applies at 25 °C. If the switch's working ambient temperature exceeds 25 °C, the load current will be lower than 20 mA. (5 to 10 mA when 60 °C)

Cylinder weight

(Unit: kg)

Descriptions, mounting style	Product weight at stroke length (S) = 0 mm								Switch weight	Switch rail + band weight	Additional weight per S = 10 mm
	Basic type (00)	Axial foot type (LB)	Axial foot type (LS)	Flange type (FA/FB)	Eye bracket type (CA)	Clevis type (CC)	Clevis bracket type (CB)	Trunnion type (TA/TB)	Grommet		
φ 20	0.17	0.32	0.25	0.23	0.32	0.18	0.32	0.22	0.018	0.005	0.01
φ 25	0.26	0.52	0.39	0.41	0.50	0.26	0.50	0.36	0.018	0.005	0.01
φ 32	0.30	0.56	0.43	0.45	0.54	0.30	0.54	0.40	0.018	0.009	0.02
φ 40	0.48	0.74	0.61	0.63	0.72	0.50	0.72	0.64	0.018	0.009	0.02

(E.g.) Product weight of CMK2-FA-32C-50-T0H-D

Product weight at S = 0 mm is 0.45 kg

Additional weight at S = 50 mm is additional weight at S=10 mm $0.02 \times \frac{\text{Product stroke length (50)}}{10} = 0.10$ kg

Weight of two switches is 0.036 kg

Weight of switch rail and two bands is 0.018 kg

Product weight is 0.45 kg + 0.1 kg + 0.036 kg + 0.018 kg = 0.604 kg

Medium bore size cylinder Standard type

CMK2-*C Series

- SCP*2
- CMK2**
- CMA2
- SCM
- SCG
- SCA2
- SCS
- CKV2
- CA/OV2
- SSD
- CAT
- MDC2
- MVC
- SMD2
- MSD*
- FC*
- STK
- ULK*
- JSK/M2
- JSG
- JSC3
- USSD
- USC
- JSB3
- LMB
- STG
- STS/L
- LCS
- LCG
- LCM
- LCT
- LCY
- STR2
- UCA2
- HCM
- HCA
- SRL2
- SRG
- SRM
- SRT
- MRL2
- MRG2
- SM-25
- CAC3
- UCAC
- RCC2
- MFC
- SHC
- GLC
- Ending

How to order

● Without switch

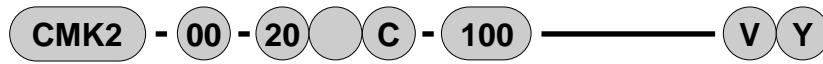

● With switch

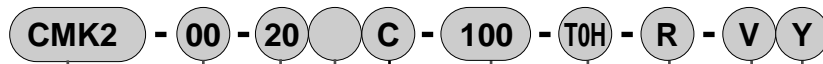

Model no.

A Mounting style
Note 1

Rubber-air
Cushioned

B Bore size

C Port thread type

D Stroke length

E Switch model no.
*Indicates lead wire length.

F Switch quantity
Note 8

G Option
Note 3, Note 4

H Accessory
Note 5

Note on model no. selection

Note 1: For single foot type (LS type), maximum stroke length is 50 mm.

Note 2: Refer to page 130 for min. stroke length with switch.

Note 3: Applicable tube O.D. of F; push-in joint (straight), FE; push-in joint (elbow) is $\phi 6$.

Note 4: Instantaneous maximum temperature is the temperature when spark and spatter etc. instantaneously contacts to bellows.

Note 5: "I" and "Y" can not be selected at the same time.

Note 6: Refer to Ending 89 for the custom order specifications of rod end form.

Note 7: Refer to page 84 for variation and combinations of options.

Note 8: Up to three switches can be mounted. If more than four switches are required, switch mounting brackets for the extra switches must be prepared separately.

<Example of model number>

CMK2-00-20C-100-T0H-R-VY

Model: Rubber-air cushioned medium bore size cylinder

- A** Mounting style : Basic type
- B** Bore size : $\phi 20$ mm
- C** Port thread type : Rc thread
- D** Stroke length : 100 mm
- E** Switch model no. : Proximity switch T0H switch, lead wire 1 m
- F** Switch quantity : One on rod end
- G** Option : Boss cut off
- H** Accessory : Rod clevis

Symbol	Descriptions
A Mounting style	
00	Basic type
LB	Axial foot type (both sides)
LS	Axial foot type (single)
FA	Rod end flange type
FB	Head end flange type
CA	Eye bracket type
CC	Fixed eye
CC1	Eye and bush press fitted type
CB	Clevis bracket type (pin and washer split pin attached)
TA	Rod end trunnion type
TB	Head end trunnion type

B Bore size (mm)	
20	$\phi 20$
25	$\phi 25$
32	$\phi 32$
40	$\phi 40$

C Port thread type	
Blank	Rc thread
N	NPT thread (custom order)
G	G thread (custom order)

D Stroke length (mm)		
Bore size	Stroke length Note 2	Custom stroke length
$\phi 20$	5 to 750	By 1 mm increment
$\phi 25$	5 to 750	
$\phi 32$	5 to 750	
$\phi 40$	5 to 750	

E Switch model no.				
Lead wire	Lead wire	Contact	Indicator	Lead wire
Straight	L type			
T0H*	T0V*	Reed	1 color indicator type	2-wire
T5H*	T5V*		Without indicator light	
T8H*	T8V*		1 color indicator type	
T1H*	T1V*	Proximity	1 color indicator type	2-wire
T2H*	T2V*		1 color indicator type (custom order)	3-wire
T3PH*	T3PV*			
T2YH*	T2YV*		2 color indicator type	2-wire
T3YH*	T3YV*		2 color indicator type (w/o light for preventive maintenance output)	3-wire
T2YFH*	T2YFV*		2 color indicator type (with light for preventive maintenance output (1 color))	4-wire
T2YMH*	T2YMV*	2 color indicator type (with light for preventive maintenance output (1 color))	3-wire	
T3YMH*	T3YMV*		4-wire	
T2JH*	T2JV*		Off-delay type	2-wire

*Lead wire length	
Blank	1 m (standard)
3	3 m (option)
5	5 m (option)

F Switch quantity	
R	One on rod end
H	One on head end
D	Two
T	Three

G Option			
		Max. ambient	Max. instantaneous
J	Bellows	100 °C	200 °C
L	Bellows	250 °C	400 °C
F	Push-in joint (straight)		
FE	Push-in joint (elbow)		
M	Piston rod material (stainless steel)		
V	Boss cut off		

H Accessory	
I	Rod eye
Y	Rod clevis (pin and washer split pin attached)
B2	Clevis bracket (pin and snap ring attached)

How to order switch

- Switch body + mounting bracket

CMK2 - **T0H** - **20**

Bore size (item ⑤ previous page)
Switch model no.
(item ④ previous page)

- Only switch body

SW - **T0H**

Switch model no.
(item ④ previous page)

- Mounting bracket

CMK2 - **T** - **20**

Bore size (item ⑤ previous page)
Bracket

How to order mounting bracket

Bore size (mm)	φ 20	φ 25	φ 32	φ 40
Mounting bracket				
Axial foot type (LB/LS)	M1-LB-20	M1-LB-30	M1-LB-30	M1-LB-30
Flange (FA/FB)	M1-FA-20	M1-FA-30	M1-FA-30	M1-FA-30
Trunnion (TA/TB)	M1-TA-20	M1-TA-30	M1-TA-30	M1-TA-40
Eye bracket type (CA)	M1-CA-20	M1-CA-30	M1-CA-30	M1-CA-30
Clevis bracket type (CB)	M1-CB-20	M1-CB-30	M1-CB-30	M1-CB-30

Note 1: Mounting nut/toothed washer are attached to each mounting bracket.

Note 2: Two sets of "M1-LB-*" in the above table are required for the axial direction foot (double-sided).

- SCP*2
- CMK2**
- CMA2
- SCM
- SCG
- SCA2
- SCS
- CKV2
- CA/OV2
- SSD
- CAT
- MDC2
- MVC
- SMD2
- MSD*
- FC*
- STK
- ULK*
- JSK/M2
- JSG
- JSC3
- USSD
- USC
- JSB3
- LMB
- STG
- STS/L
- LCS
- LCG
- LCM
- LCT
- LCY
- STR2
- UCA2
- HCM
- HCA
- SRL2
- SRG
- SRM
- SRT
- MRL2
- MRG2
- SM-25
- CAC3
- UCAC
- RCC2
- MFC
- SHC
- GLC
- Ending

Medium bore size cylinder
Standard type

Internal structure and parts list

● CMK2-*C

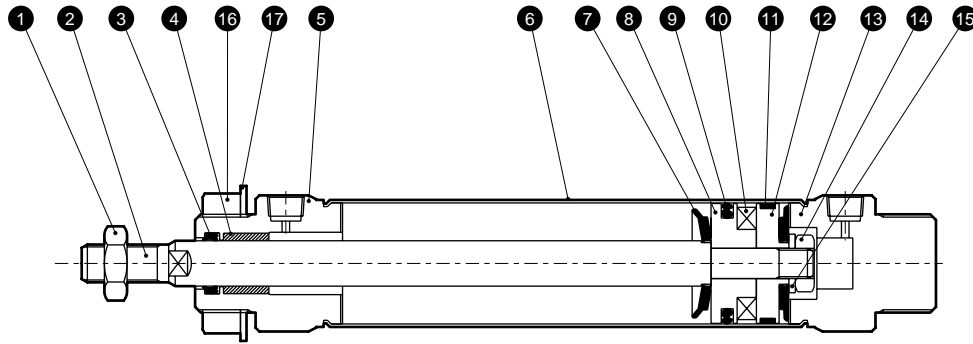

● Note: This caulking type cannot be disassembled.

No.	Parts name	Material	Remarks	No.	Parts name	Material	Remarks
1	Rod nut	Steel	Zinc chromate	11	Wear ring	Polyacetal	
2	Piston rod	$\phi 20, \phi 25$: stainless steel $\phi 32, \phi 40$: carbon steel	Industrial chrome plating	12	Piston B	Aluminum alloy	
3	Rod packing seal	Nitrile rubber		13	Head cover	Aluminum alloy	
4	Bush	$\phi 20$: dry bearing $\phi 25, \phi 32, \phi 40$: copper		14	Hexagon nut	Steel	Zinc chromate
5	Rod cover	Aluminum alloy		15	Spacer	Steel	Zinc chromate
6	Cylinder tube	Stainless steel		16	Nut	Steel	Zinc chromate
7	Rubber-air cushion	Special rubber		17	Toothed washer	Steel	Zinc chromate
8	Piston A	Aluminum alloy					
9	Piston packing seal	Nitrile rubber					
10	Magnet	Plastic					

Dimensions

● Basic type with T type switch (00)

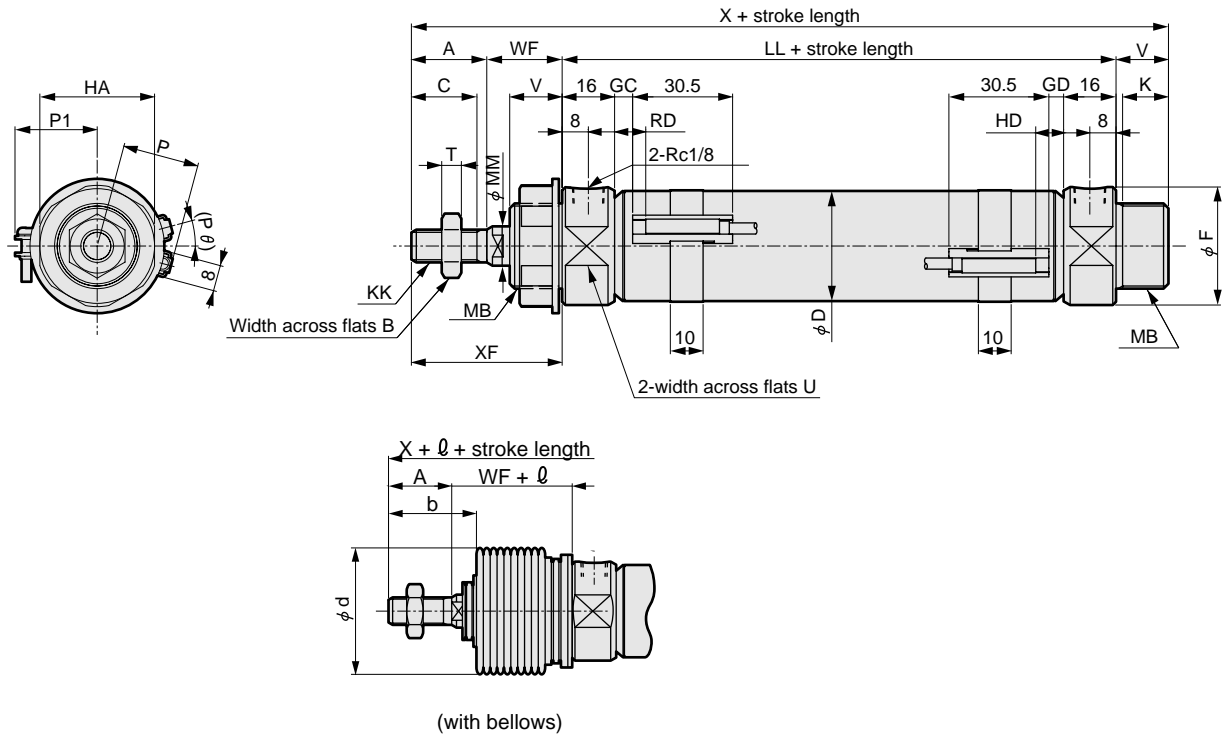

Note 1: Refer to page 188 for the HD, RD, and projecting dimensions of the T1* and T8* switches and 2-color indicator switch with preventive maintenance output.

RD: Rod side max. sensitive position
HD: Head side max. sensitive position

Note 2: For l dimensions, round up decimal point or less.
Note 3: Refer to page 190 for dimensions of accessories.

Symbol	Basic dimensions for basic type (00)													
Bore size (mm)	A	B	C	D	F	HA	K	KK	LL	MB	MM	T	U	V
φ 20	20	13	18	21.4	28	26	12	M8 x 1.0	66	M18 x 1.5	10	5	24	14
φ 25	23	17	20	26.4	32	35	14	M10 x 1.25	69	M26 x 1.5	12	6	30	16
φ 32	23	17	20	33.6	36	35	14	M10 x 1.25	69	M26 x 1.5	12	6	34	16
φ 40	25	19	22	41.6	45	35	14	M12 x 1.5	73	M26 x 1.5	14	7	43	16
Symbol	With switch										With bellows			
Bore size (mm)	WF	X	XF	GC	GD	RD	HD	P	P1	(P θ)°	b	d	l	
φ 20	24	124	44	4.0	3.0	8.0	7.0	17.3	19.5	22	30	30	(stroke length/3) + 6	
φ 25	23	131	46	5.5	4.5	9.5	8.5	19.8	22.0	18	32	46	(stroke length/3.25) + 7	
φ 32	23	131	46	5.5	4.5	9.5	8.5	24.3	25.5	15	32	46	(stroke length/3.25) + 7	
φ 40	23	137	48	7.0	6.5	11.5	10.5	28.3	29.5	12	34	46	(stroke length/3.25) + 7	

Refer to pages 96 to 101 for mounting style other than basic type (00).

- SCP*2
- CMK2**
- CMA2
- SCM
- SCG
- SCA2
- SCS
- CKV2
- CA/OV2
- SSD
- CAT
- MDC2
- MVC
- SMD2
- MSD*
- FC*
- STK
- ULK*
- JSK/M2
- JSG
- JSC3
- USSD
- USC
- JSB3
- LMB
- STG
- STS/L
- LCS
- LCG
- LCM
- LCT
- LCY
- STR2
- UCA2
- HCM
- HCA
- SRL2
- SRG
- SRM
- SRT
- MRL2
- MRG2
- SM-25
- CAC3
- UCAC
- RCC2
- MFC
- SHC
- GLC
- Ending

Medium bore size cylinder
Standard type

Technical data

- SCP*2
- CMK2**
- CMA2
- SCM
- SCG
- SCA2
- SCS
- CKV2
- CA/OV2
- SSD
- CAT
- MDC2
- MVC
- SMD2
- MSD*
- FC*
- STK
- ULK*
- JSK/M2
- JSG
- JSC3
- USSD
- USC
- JSB3
- LMB
- STG
- STS/L
- LCS
- LCG
- LCM
- LCT
- LCY
- STR2
- UCA2
- HCM
- HCA
- SRL2
- SRG
- SRM
- SRT
- MRL2
- MRG2
- SM-25
- CAC3
- UCAC
- RCC2
- MFC
- SHC
- GLC
- Ending

[Comparison of colliding noise levels]

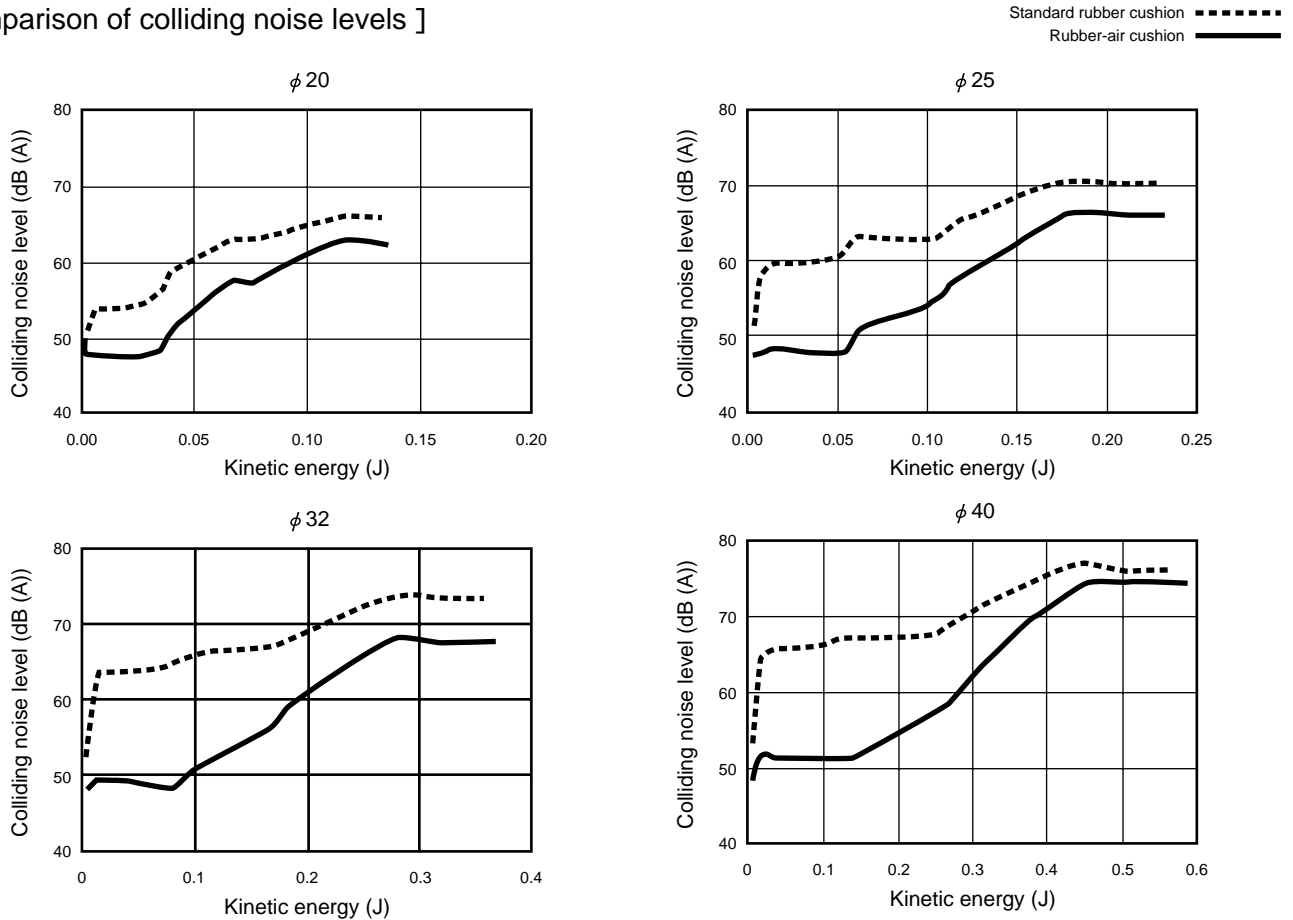

[Comparison of colliding acceleration]

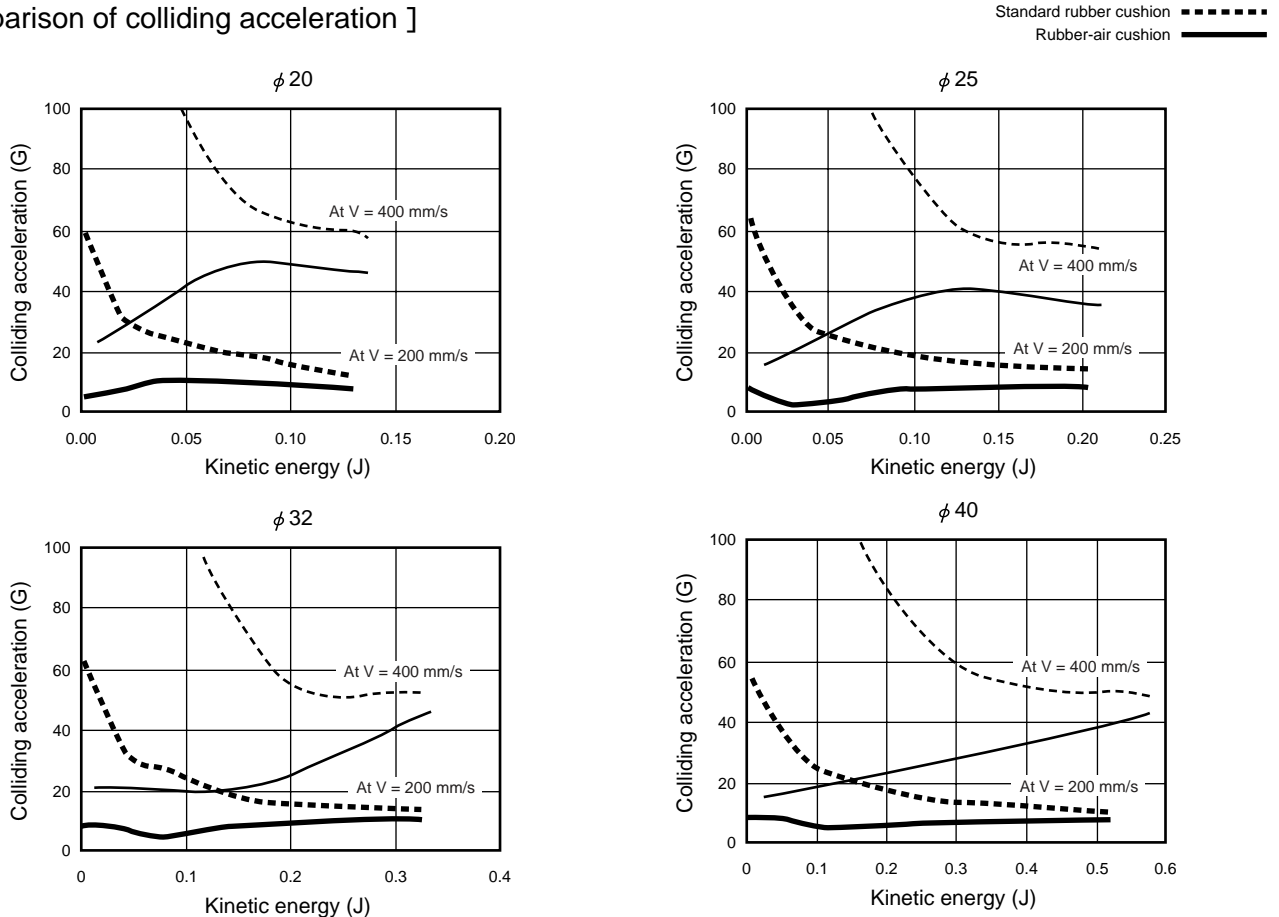

Technical data

(Allowable energy)

● CMK2

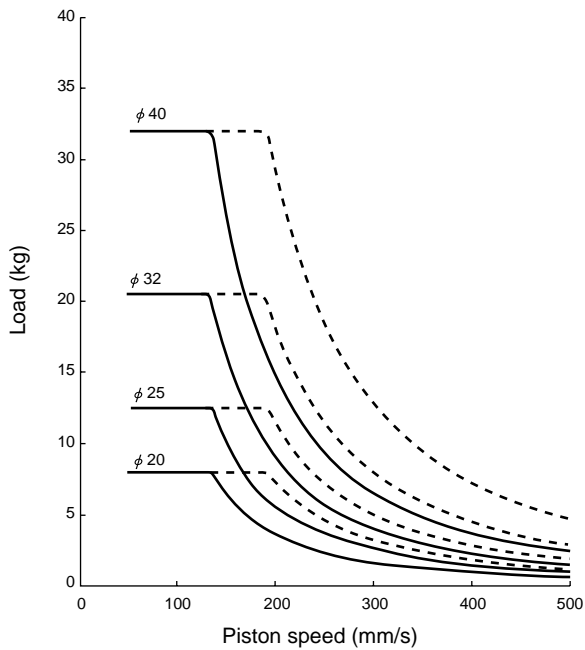

The area left and below from the curve is the usable range.
 This product can be used within the range indicated as --- on the graph.
 However, to increase the effect of noise reduction and deceleration,
 we recommend to use this product within the range of continuous line.

SCP*2
CMK2
CMA2
SCM
SCG
SCA2
SCS
CKV2
CA/OV2
SSD
CAT
MDC2
MVC
SMD2
MSD*
FC*
STK
ULK*
JSK/M2
JSG
JSC3
USSD
USC
JSB3
LMB
STG
STS/L
LCS
LCG
LCM
LCT
LCY
STR2
UCA2
HCM
HCA
SRL2
SRG
SRM
SRT
MRL2
MRG2
SM-25
CAC3
UCAC
RCC2
MFC
SHC
GLC
Ending

Medium bore size cylinder
 Standard type

SCP*2
CMK2
 CMA2
 SCM
 SCG
 SCA2
 SCS
 CKV2
 CA/OV2
 SSD
 CAT
 MDC2
 MVC
 SMD2
 MSD*
 FC*
 STK
 ULK*
 JSK/M2
 JSG
 JSC3
 USSD
 USC
 JSB3
 LMB
 STG
 STS/L
 LCS
 LCG
 LCM
 LCT
 LCY
 STR2
 UCA2
 HCM
 HCA
 SRL2
 SRG
 SRM
 SRT
 MRL2
 MRG2
 SM-25
 CAC3
 UCAC
 RCC2
 MFC
 SHC
 GLC
 Ending

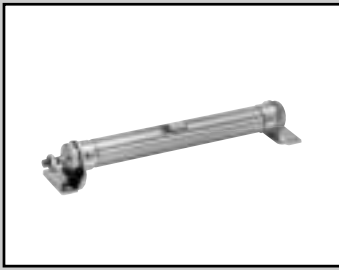

Medium bore size cylinder
 Double acting air cushioned

CMK2-C Series

● Bore size: $\phi 20$, $\phi 25$, $\phi 32$, $\phi 40$

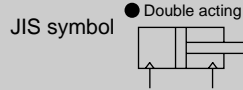

Specifications

Descriptions		CMK2-C			
Bore size	mm	$\phi 20$	$\phi 25$	$\phi 32$	$\phi 40$
Actuation		Double acting air cushioned			
Working fluid		Compressed air			
Max. working pressure	MPa	1.0			
Min. working pressure	MPa	0.1			
Withstanding pressure	MPa	1.6			
Ambient temperature	°C	-10 to 60 (no freezing)			
Port size		Rc1/8			
Stroke tolerance	mm	$^{+2.0}_0$ (up to 200), $^{+2.4}_0$ (over 200)			
Working piston speed	mm/s	50 to 700			
Cushion		Air cushion			
Effective cushion length	mm	12			
Allowable energy absorption	J	0.34	0.46	0.88	1.27
Lubrication		Not required (when lubricating, use turbine oil Class 1 ISO VG32.)			

Stroke length

Bore size (mm)	Standard stroke length (mm)	Max. stroke length (mm)	Min. stroke length (mm)
$\phi 20$	25, 50, 75, 100, 150, 200, 250, 300	750	5
$\phi 25$			
$\phi 32$			
$\phi 40$			

Note 1: Custom stroke length is available per 1 mm increment.
 Note 2: For single foot type (LS type), maximum stroke length is 50 mm.
 Note 3: For bellows "J" type, stroke length should be longer than 25 mm.
 Consult with CKD when stroke length is shorter than 25 mm.

Min. stroke length of type with switch

(Unit: mm)

Switch quantity Bore size (mm)	1				2				3			
	Proximity		Reed		Proximity		Reed		Proximity		Reed	
	T2, T3	T1, T*Y*	T0, T5	T8	T2, T3	T1, T*Y*	T0, T5	T8	T2, T3	T1, T*Y*	T0, T5	T8
$\phi 20$	10				25	35	25	35	50	55	50	55
$\phi 25$	10				25	35	25	35	50	55	50	55
$\phi 32$	10				25	35	25	35	50	55	50	55
$\phi 40$	10				25	35	25	35	50	55	50	55

Note 1: Up to three switches can be mounted.

SCP*2
CMK2
CMA2
SCM
SCG
SCA2
SCS
CKV2
CA/OV2
SSD
CAT
MDC2
MVC
SMD2
MSD*
FC*
STK
ULK*
JSK/M2
JSG
JSC3
USSD
USC
JSB3
LMB
STG
STS/L
LCS
LCG
LCM
LCT
LCY
STR2
UCA2
HCM
HCA
SRL2
SRG
SRM
SRT
MRL2
MRG2
SM-25
CAC3
UCAC
RCC2
MFC
SHC
GLC
Ending

Switch specifications

● 1 color/2 color indicator

* The T0/T5 switch can be used with 220 VAC.
Contact CKD for working conditions.

Descriptions	Proximity 2-wire			Proximity 3-wire			Reed 2-wire						
	T1H/T1V	T2H/T2V/ T2JH/T2JV	T2YH/T2YV	T3H/T3V	T3PH/T3PV (Custom order)	T3YH/T3YV	TOH/TOV		T5H/T5V		T8H/T8V		
Applications	Programmable controller Relay, small solenoid valve		Programmable controller dedicated	Programmable controller, relay			Programmable controller, relay		Programmable controller, relay, IC circuit (w/o light), serial connection		Programmable controller, relay		
Output method	-			NPN output	PNP output	NPN output	-						
Power voltage	-			10 to 28 VDC			-						
Load voltage	85 to 265 VAC		10 to 30 VDC	30 VDC or less			12/24 VDC	110 VAC	5/12/24 VDC	110 VAC	12/24 VDC	110 VAC	220 VAC
Load current	5 to 100 mA		5 to 20 mA (Note 1)	100 mA or less		50 mA or less	5 to 50 mA	7 to 20 mA	50 mA or less	20 mA or less	5 to 50 mA	7 to 20 mA	7 to 10 mA
Light	LED (ON lighting)		LED (ON lighting)	Red/green LED (ON lighting)	LED (ON lighting)	Green LED (ON lighting)	Red/Green LED (ON lighting)	LED (ON lighting)		Without indicator light		LED (ON lighting)	
Leakage current	1 mA or less with 100 VAC 2 mA or less with 200 VAC		1 mA or less	10 μA or less			0 mA						

● With preventive maintenance output

Descriptions	Proximity 3-wire		Proximity 4-wire		Proximity 3-wire		Proximity 4-wire		
	T2YFH/V		T3YFH/V		T2YMH/V		T3YMH/V		
Applications	Programmable controller dedicated		Programmable controller, relay		Programmable controller dedicated		Programmable controller, relay		
Output method	NPN output								
Light	Red/Green LED (ON lighting)								
	Installation position adjustment		-				Yellow LED (ON lighting)		
Regular Output section	Power voltage		10 to 28 VDC		-		10 to 28 VDC		
	Load voltage		30 VDC or less		10 to 30 VDC		30 VDC or less		
	Load current		50 mA or less		5 to 20 mA		50 mA or less		
	Leakage current		10 μA or less		1.2 mA or less		10 μA or less		
Preventive maintenance Output section	30 VDC or less								
	Load current		50 mA or less		5 to 20 mA or less		50 mA or less		
	10 μA or less								

Note 1: Refer to Ending 1 for other switches.

Note 2: The above maximum load current of 20 mA applies at 25 °C. If the switch's working ambient temperature exceeds 25 °C, the load current will be lower than 20 mA.
(5 to 10 mA when 60 °C)

Cylinder weight

(Unit: kg)

Descriptions/mounting style	Product weight when stroke length (S) = 0 mm								Switch weight	Switch rail + band weight	Additional weight per S = 10 mm
	Basic (00)	Axial foot (LB)	Axial foot (LS)	Flange (FA/FB)	Eye bracket (CA)	Clevis (CC)	Clevis bracket (CB)	Trunnion (TA/TB)	Grommet		
φ20	0.17	0.32	0.25	0.23	0.32	0.18	0.32	0.22	0.018	0.005	0.01
φ25	0.26	0.52	0.39	0.41	0.50	0.26	0.50	0.36	0.018	0.005	0.01
φ32	0.30	0.56	0.43	0.45	0.54	0.30	0.54	0.40	0.018	0.009	0.02
φ40	0.48	0.74	0.61	0.63	0.72	0.50	0.72	0.64	0.018	0.009	0.02

(E.g.) Product weight of
CMK2-C-FA-32-50-T0H-D

When S = 0 mm, product weight is 0.45 kg
 Additional weight at S = 50 mm is additional weight at S = 10 mm 0.02 X $\frac{\text{Product stroke length (50)}}{10}$ = 0.10 kg
 Weight of two switches is 0.036 kg
 Weight of switch rail and two bands is 0.018 kg
 Product weight is 0.45 kg + 0.1 kg + 0.036 kg + 0.018 kg = 0.604 kg

Medium bore size cylinder
Standard type

- SCP*2
- CMK2**
- CMA2
- SCM
- SCG
- SCA2
- SCS
- CKV2
- CA/OV2
- SSD
- CAT
- MDC2
- MVC
- SMD2
- MSD*
- FC*
- STK
- ULK*
- JSK/M2
- JSG
- JSC3
- USSD
- USC
- JSB3
- LMB
- STG
- STS/L
- LCS
- LCG
- LCM
- LCT
- LCY
- STR2
- UCA2
- HCM
- HCA
- SRL2
- SRG
- SRM
- SRT
- MRL2
- MRG2
- SM-25
- CAC3
- UCAC
- RCC2
- MFC
- SHC
- GLC
- Ending

How to order

Without switch
CMK2-C - **00** - **20** - **100** - **V** **I**

With switch
CMK2-C - **00** - **20** - **100** - **T0H** - **R** - **V** **I**

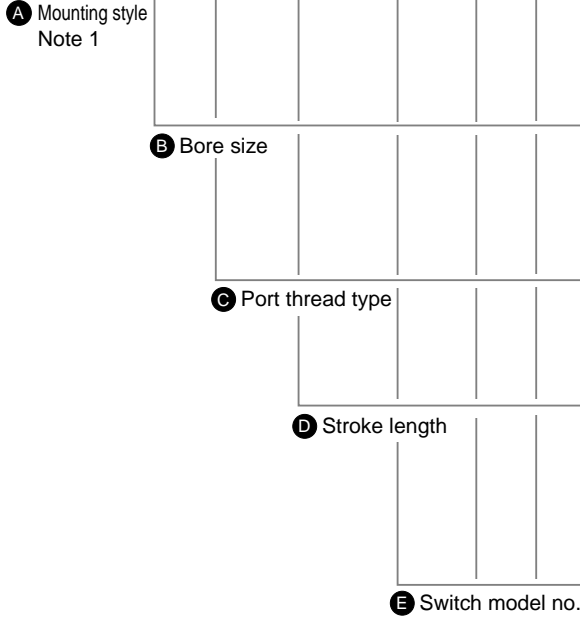

Note on model no. selection

- Note 1: The maximum stroke of the single-end foot type (LS type) is 50 mm.
- Note 2: Refer to page 138 for min. stroke length with switch.
- Note 3: Applicable tube O.D. of F; push-in joint (straight), FE; push-in joint (elbow) is $\phi 6$.
- Note 4: For bellows "J" type, stroke length should be more than 25 mm. Consult with CKD when stroke length is shorter than 25 mm.
- Note 5: Instantaneous maximum temperature is the temperature when spark and spatter etc. instantaneously contacts to bellows.
- Note 6: "I" and "Y" can not be selected at the same time.
- Note 7: Refer to Ending 89 for the custom order specifications of rod end form.
- Note 8: Refer to page 84 for variation and combinations of options.
- Note 9: Up to three switches can be mounted. If more than four switches are required, switch mounting brackets for the extra switches must be prepared separately.

<Example of model number>
CMK2-C-00-20-100-T0H-R-VI

Model: Medium bore size cylinder, double acting, air cushioned

- A** Mounting style : Basic type
- B** Bore size : $\phi 20$ mm
- C** Port thread type : Rc thread
- D** Stroke length : 100 mm
- E** Switch model no. : Reed T0H switch and lead wire 1 m
- F** Switch quantity : One on rod end
- G** Option : Boss cut off
- H** Accessory : Rod eye

F Switch quantity
Note 9

G Option
Note 3, Note 4, Note 5

H Accessory
Note 6

Symbol	Descriptions
A Mounting style	
00	Basic type
LB	Axial foot type (both sides)
LS	Axial foot type (single)
FA	Rod side flange type
FB	Head side flange type
CA	Eye bracket type
CC	Fixed eye
CC1	Eye and bush press fitted type
CB	Clevis bracket type (pin and washer split pin attached)
TA	Rod side trunnion type
TB	Head side trunnion type

B Bore size (mm)	
20	$\phi 20$
25	$\phi 25$
32	$\phi 32$
40	$\phi 40$

C Port thread type	
Blank	Rc thread
NN	NPT thread (custom order)
GN	G thread (custom order)

D Stroke length (mm)		
Bore size	Stroke length Note 2	Custom stroke length
$\phi 20$	5 to 750	By 1 mm increment
$\phi 25$	5 to 750	
$\phi 32$	5 to 750	
$\phi 40$	5 to 750	

E Switch model no.					
Lead wire Straight type	Lead wire L type	Contact	Indicator	Lead wire	
T0H*	T0V*	Reed	1 color	2-wire	
T5H*	T5V*		Without indicator light		
T8H*	T8V*		1 color		
T1H*	T1V*	Proximity	1 color	2-wire	
T2H*	T2V*				
T3H*	T3V*		1 color (custom order)	3-wire	
T3PH*	T3PV*				
T2YH*	T2YV*		2 color	2 color	2-wire
T3YH*	T3YV*				
T2YFH*	T2YFV*	2 color (w/o light for preventive maintenance output)		4 wire	
T3YFH*	T3YFV*				
T2YMH*	T2YMV*	2 color (Light available for preventive maintenance output (1 color))	3-wire		
T3YMH*	T3YMV*				
T2JH*	T2JV*	Off-delay type	2-wire		

* Lead wire length	
Blank	1 m (standard)
3	3 m (option)
5	5 m (option)

F Switch quantity	
R	One on rod end
H	One on head end
D	Two
T	Three

G Option			
		Max. ambient	Max. instantaneous
J	Bellows	100 °C	200 °C
L	Bellows	250 °C	400 °C
F	Push-in joint (straight)		
FE	Push-in joint (elbow)		
M	Piston rod material (stainless steel)		
V	Boss cut off		

H Accessory	
I	Rod eye
Y	Rod clevis (pin and washer split pin attached)
B2	Clevis bracket (pin and snap ring attached)

How to order switch

- Switch body + mounting bracket

CMK2 - **T0H** - **20**

Bore size (item ⑤ on previous page)

Switch model no. (item ④ on previous page)

- Only switch body

SW - **T0H**

Switch model no. (item ④ on previous page)

- Mounting bracket

CMK2 - **T** - **20**

Bore size

(item ⑤ on previous page)

Bracket

How to order mounting bracket

Bore size (mm)	$\phi 20$	$\phi 25$	$\phi 32$	$\phi 40$
Mounting bracket				
Axial foot type (LB/LS)	M1-LB-20	M1-LB-30	M1-LB-30	M1-LB-30
Flange (FA/FB)	M1-FA-20	M1-FA-30	M1-FA-30	M1-FA-30
Trunnion (TA/TB)	M1-TA-20	M1-TA-30	M1-TA-30	M1-TA-40
Eye bracket type (CA)	M1-CA-20	M1-CA-30	M1-CA-30	M1-CA-30
Clevis bracket type (CB)	M1-CB-20	M1-CB-30	M1-CB-30	M1-CB-30

Note 1: Mounting nut/toothed washer are attached to each mounting bracket.

Note 2: Two sets of "M1-LB-*" in the above table are required for the axial direction foot (double-sided).

SCP*2
CMK2
CMA2
SCM
SCG
SCA2
SCS
CKV2
CA/OV2
SSD
CAT
MDC2
MVC
SMD2
MSD*
FC*
STK
ULK*
JSK/M2
JSG
JSC3
USSD
USC
JSB3
LMB
STG
STS/L
LCS
LCG
LCM
LCT
LCY
STR2
UCA2
HCM
HCA
SRL2
SRG
SRM
SRT
MRL2
MRG2
SM-25
CAC3
UCAC
RCC2
MFC
SHC
GLC
Ending

Medium bore size cylinder
Standard type

Internal structure and parts list

● CMK2-C

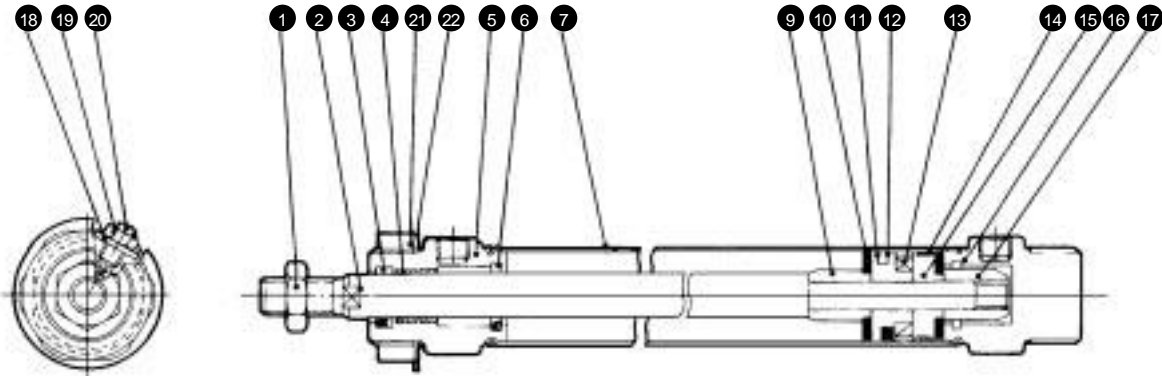

● Note: This caulking type cannot be disassembled.

No.	Parts name	Material	Remarks	No.	Parts name	Material	Remarks
1	Rod nut	Steel	Zinc chromate	14	Wear ring	Polyacetal	
2	Piston rod	$\phi 20, \phi 25$: Stainless steel $\phi 32, \phi 40$: Carbon steel	Industrial chrome plating	15	Piston B	Aluminum alloy	
3	Rod packing seal	Nitrile rubber		16	Head cover	Aluminum alloy	
4	Bush	$\phi 20, \phi 25, \phi 32$: Dry bearing $\phi 40$: Copper		17	Cushion ring B	Aluminum alloy	
5	Rod cover	Aluminum alloy		18	Die thread	Nitrile rubber and steel	
6	Cushion packing seal	Urethane rubber		19	Hexagon nut	Steel	Zinc chromate
7	Cylinder tube	Stainless steel		20	Cushion adjustment needle	Copper	Zinc chromate
9	Cushion ring A	Aluminum alloy		21	Nut	Steel	Zinc chromate
10	Cushion rubber	Urethane rubber		22	The toothed washer	Steel	Zinc chromate
11	Piston A	Aluminum alloy					
12	Piston packing seal	Nitrile rubber					
13	Magnet	Plastic					

Dimensions

- Basic type (00)
T type with switch

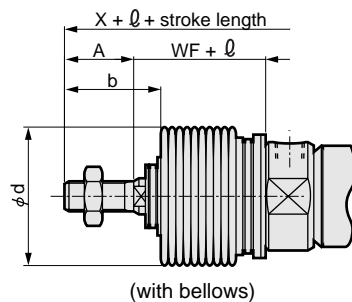
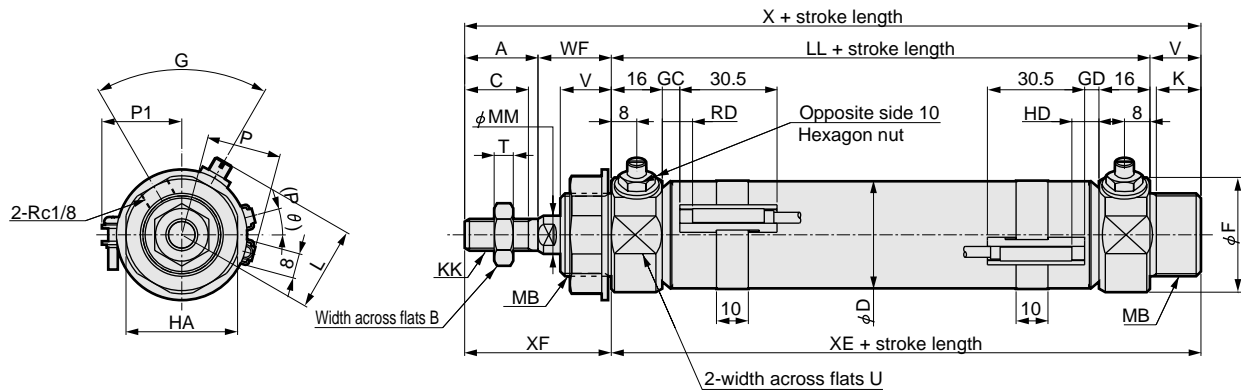

Note 1: Refer to page 188 for the HD, RD, and projecting dimensions of the T1* and T8* switches and 2-color indicator switch with preventive maintenance output.

RD: Rod side max. sensitive position
HD: Head side max. sensitive position

Note 2: For ϕ dimensions, round up decimal point or less.
Note 3: Refer to page 190 for dimensions of accessories.

Symbol	A	B	C	D	F	G	HA	K	KK	L	LL	MB	MM	T	U	V	WF	X	XE	XF
Bore size (mm)																				
φ20	20	13	18	21.4	28	70	26	12	M8 x 1.0	23 to 25	66	M18 x 1.5	10	5	24	14	24	124	80	44
φ25	23	17	20	26.4	32	60	35	14	M10 x 1.25	25 to 27	69	M26 x 1.5	12	6	30	16	23	131	85	46
φ32	23	17	20	33.6	36	60	35	14	M10 x 1.25	25 to 26.5	69	M26 x 1.5	12	6	34	16	23	131	85	46
φ40	25	19	22	41.6	45	60	35	14	M12 x 1.5	31.5 to 33	73	M26 x 1.5	14	7	43	16	23	137	89	48
Symbol	With switch							With bellows												
Bore size (mm)	GC	GD	RD	HD	P	P1	(Pθ) ²	b	d	φ										
φ20	4.0	3.0	8.0	7.0	17.3	19.5	22	30	30	(stroke length/3) + 6										
φ25	5.5	4.5	9.5	8.5	19.8	22.0	18	32	46	(stroke length/3.25) + 7										
φ32	5.5	4.5	9.5	8.5	24.3	25.5	15	32	46	(stroke length/3.25) + 7										
φ40	7.0	6.5	11.5	10.5	28.3	29.5	12	34	46	(stroke length/3.25) + 7										

Dimensions of each mounting type are same as standard type. Refer to pages 96 to 101.

SCP*2
CMK2
CMA2
SCM
SCG
SCA2
SCS
CKV2
CA/OV2
SSD
CAT
MDC2
MVC
SMD2
MSD*
FC*
STK
ULK*
JSK/M2
JSG
JSC3
USSD
USC
JSB3
LMB
STG
STS/L
LCS
LCG
LCM
LCT
LCY
STR2
UCA2
HCM
HCA
SRL2
SRG
SRM
SRT
MRL2
MRG2
SM-25
CAC3
UCAC
RCC2
MFC
SHC
GLC
Ending

Medium bore size cylinder
Standard type

SCP*2
CMK2
 CMA2
 SCM
 SCG
 SCA2
 SCS
 CKV2
 CA/OV2
 SSD
 CAT
 MDC2
 MVC
 SMD2
 MSD*
 FC*
 STK
 ULK*
 JSK/M2
 JSG
 JSC3
 USSD
 USC
 JSB3
 LMB
 STG
 STS/L
 LCS
 LCG
 LCM
 LCT
 LCY
 STR2
 UCA2
 HCM
 HCA
 SRL2
 SRG
 SRM
 SRT
 MRL2
 MRG2
 SM-25
 CAC3
 UCAC
 RCC2
 MFC
 SHC
 GLC
 Ending

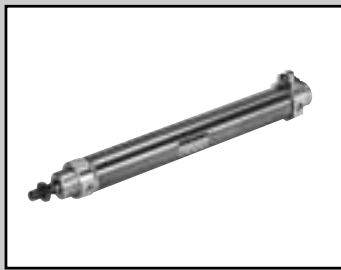

Medium bore size cylinder
 Double acting position locking type

CMK2-Q Series

● Bore size: ϕ 20, ϕ 25, ϕ 32, ϕ 40

JIS symbol

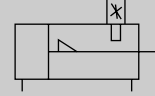
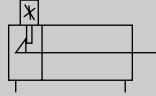

Specifications

Descriptions		CMK2-Q			
Bore size	mm	ϕ 20	ϕ 25	ϕ 32	ϕ 40
Actuation		Double acting position locking type			
Working fluid		Compressed air			
Max. working pressure	MPa	1.0			
Min. working pressure	MPa	0.15			
Withstanding pressure	MPa	1.6			
Ambient temperature	°C	-10 to 60 (no freezing)			
Port size		Rc1/8			
Stroke tolerance	mm	$^{+2.0}_0$ (up to 200), $^{+2.4}_0$ (over 200)			
Working piston speed	mm/s	50 to 500			
Cushion		Rubber cushion			
Lubrication		Not required (when lubricating, use turbine oil Class 1 ISO VG32.)			
Position locking mechanism		Head side or rod side			
Holding force	N	Maximum thrust x 0.7			
Allowable energy absorption	J	0.166	0.308	0.424	0.639

Stroke length

Bore size (mm)	Standard stroke length (mm)	Max. stroke length (mm)	Min. stroke length (mm)
ϕ 20	25, 50, 75, 100, 150, 200, 250, 300	750	5
ϕ 25			
ϕ 32			
ϕ 40			

Note 1: Custom stroke length is available per 1 mm increment.

Note 2: For bellows "J" type, stroke length should be longer than 25 mm.

Consult with CKD when stroke length is shorter than 25 mm.

Min. stroke length of type with switch

(Unit: mm)

Switch quantity	1					2					3				
	Proximity		Reed			Proximity		Reed			Proximity		Reed		
	T2, T3	T1, T*Y*	T0, T5	T8	T2, T3	T1, T*Y*	T0, T5	T8	T2, T3	T1, T*Y*	T0, T5	T8			
ϕ 20	10					25	35	25	35	50	55	50	55		
ϕ 25	10					25	35	25	35	50	55	50	55		
ϕ 32	10					25	35	25	35	50	55	50	55		
ϕ 40	10					25	35	25	35	50	55	50	55		

Note 1: Up to three switches can be mounted.

Read the Safety Precautions for Position Locking Mechanism on pages 88 and 89 before starting use.

Switch specifications

- 1 color/2 color indicator

* The T0/T5 switch can be used with 220 VAC. Contact CKD for working conditions.

Descriptions	Proximity 2-wire			Proximity 3-wire			Reed 2-wire						
	T1H/T1V	T2H/T2V/ T2JH/T2JV	T2YH/T2YV	T3H/T3V	T3PH/T3PV (Custom order)	T3YH/T3YV	TOH/TOV		T5H/T5V		T8H/T8V		
Applications	Programmable controller Relay, small solenoid valve		Programmable controller dedicated	Programmable controller, relay			Programmable controller, relay		Programmable controller, relay, IC circuit (w/o light), serial connection		Programmable controller, relay		
Output method	-			NPN output	PNP output	NPN output	-						
Power voltage	-			10 to 28 VDC			-						
Load voltage	85 to 265 VAC		10 to 30 VDC	30 VDC or less			12/24 VDC	110 VAC	5/12/24 VDC	110 VAC	12/24 VDC	110 VAC	220 VAC
Load current	5 to 100 mA		5 to 20 mA (Note 1)	100 mA or less		50 mA or less	5 to 50 mA	7 to 20 mA	50 mA or less	20 mA or less	5 to 50 mA	7 to 20 mA	7 to 10 mA
Light	LED (ON lighting)		LED (ON lighting)	Red/green LED (ON lighting)	LED (ON lighting)	Green LED (ON lighting)	Red/Green LED (ON lighting)	LED (ON lighting)		Without indicator light		LED (ON lighting)	
Leakage current	1 mA or less with 100 VAC 2 mA or less with 200 VAC		1 mA or less	10 μA or less			0 mA						

- With preventive maintenance output

Descriptions	Proximity 3-wire		Proximity 4-wire		Proximity 3-wire		Proximity 4-wire	
	T2YFH/V		T3YFH/V		T2YMH/V		T3YMH/V	
Applications	Programmable controller dedicated		Programmable controller, relay		Programmable controller dedicated		Programmable controller, relay	
Output method	NPN output							
Light	Red/Green LED (ON lighting)							
	Installation position adjustment		-		Yellow LED (ON lighting)			
Regular Output section	Power voltage		10 to 28 VDC		-		10 to 28 VDC	
	Load voltage		30 VDC or less		10 to 30 VDC		30 VDC or less	
	Load current		50 mA or less		5 to 20 mA		50 mA or less	
	Leakage current		10 μA or less		1.2 mA or less		10 μA or less	
Preventive maintenance Output section	30 VDC or less							
	Load current		50 mA or less		5 to 20 mA or less		50 mA or less	
	10 μA or less							

Note 1: Refer to Ending 1 for other switches.

Note 2: The above maximum load current of 20 mA applies at 25 °C. If the switch's working ambient temperature exceeds 25 °C, the load current will be lower than 20 mA. (5 to 10 mA when 60 °C)

Cylinder weight

- CMK2-Q-H

(Unit: kg)

Descriptions/mounting style	Product weight when stroke length (S) = 0 mm								Switch weight	Switch rail + band weight	Additional weight per S = 10 mm
	Basic (00)	Axial foot (LB)	Axial foot (LS)	Flange (FA/FB)	Eye bracket (CA)	Clevis (CC)	Clevis bracket (CB)	Trunnion (TA/TB)	Grommet		
φ 20	0.20	0.35	0.28	0.26	0.35	0.21	0.35	0.25	0.018	0.005	0.01
φ 25	0.29	0.55	0.42	0.44	0.53	0.29	0.53	0.39	0.018	0.005	0.01
φ 32	0.32	0.58	0.45	0.47	0.56	0.32	0.56	0.42	0.018	0.009	0.02
φ 40	0.51	0.77	0.64	0.66	0.75	0.53	0.75	0.67	0.018	0.009	0.02

- CMK2-Q-R

(Unit: kg)

Descriptions/mounting style	Product weight when stroke length (S) = 0 mm								Switch weight	Switch rail + band weight	Additional weight per S = 10 mm
	Basic (00)	Axial foot (LB)	Axial foot (LS)	Flange (FA/FB)	Eye bracket (CA)	Clevis (CC)	Clevis bracket (CB)	Trunnion (TA/TB)	Grommet		
φ 20	0.19	0.34	0.27	0.25	0.34	0.20	0.34	0.24	0.018	0.005	0.01
φ 25	0.29	0.55	0.42	0.44	0.53	0.29	0.53	0.39	0.018	0.005	0.01
φ 32	0.32	0.58	0.45	0.47	0.56	0.32	0.56	0.42	0.018	0.009	0.02
φ 40	0.50	0.76	0.63	0.65	0.74	0.52	0.74	0.66	0.018	0.009	0.02

(E.g.) Product weight of
CMK2-Q-FA-32-50-R-T0H-D

When S = 0 mm, product weight is 0.47 kg
 Additional weight at S = 50 mm is additional weight at S = 10 mm $0.02 \times \frac{\text{Product stroke length (50)}}{10} = 0.10$ kg
 Weight of two switches is 0.036 kg
 Weight of switch rail and two bands is 0.018 kg
 Product weights is 0.47 kg + 0.1 kg + 0.036 kg + 0.018 kg = 0.624 kg

SCP*2
 CMK2
 CMA2
 SCM
 SCG
 SCA2
 SCS
 CKV2
 CA/OV2
 SSD
 CAT
 MDC2
 MVC
 SMD2
 MSD*
 FC*
 STK
 ULK*
 JSK/M2
 JSG
 JSC3
 USSD
 USC
 JSB3
 LMB
 STG
 STS/L
 LCS
 LCG
 LCM
 LCT
 LCY
 STR2
 UCA2
 HCM
 HCA
 SRL2
 SRG
 SRM
 SRT
 MRL2
 MRG2
 SM-25
 CAC3
 UCAC
 RCC2
 MFC
 SHC
 GLC

Ending

Medium bore size cylinder
 Standard type

- SCP*2
- CMK2**
- CMA2
- SCM
- SCG
- SCA2
- SCS
- CKV2
- CA/OV2
- SSD
- CAT
- MDC2
- MVC
- SMD2
- MSD*
- FC*
- STK
- ULK*
- JSK/M2
- JSG
- JSC3
- USSD
- USC
- JSB3
- LMB
- STG
- STS/L
- LCS
- LCG
- LCM
- LCT
- LCY
- STR2
- UCA2
- HCM
- HCA
- SRL2
- SRG
- SRM
- SRT
- MRL2
- MRG2
- SM-25
- CAC3
- UCAC
- RCC2
- MFC
- SHC
- GLC
- Ending

How to order

Without switch

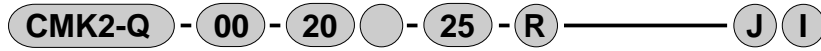

With switch

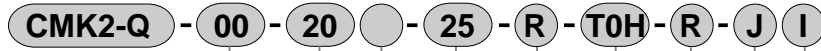

A Mounting style
Note 1

B Bore size

C Port thread type

D Stroke length

E Position locking mechanism

F Switch model no.

G Switch quantity
Note 7

H Option
Note 3
Note 8

I Accessory
Note 4

Symbol	Descriptions
A Mounting style	
00	Basic type
LB	Axial foot type
FA	Rod side flange type
FB	Head side flange type
CA	Eye bracket type
CB	Clevis bracket type (pin and washer split pin attached)
TA	Rod side trunnion type
TB	Head side trunnion type

B Bore size (mm)	
20	φ 20
25	φ 25
32	φ 32
40	φ 40

C Port thread type	
Blank	Rc thread
NN	NPT thread (custom order)
GN	G thread (custom order)

D Stroke length (mm)		
Bore size	Stroke length Note 2	Custom stroke length
φ 20	5 to 750	By 1 mm increment
φ 25	5 to 750	
φ 32	5 to 750	
φ 40	5 to 750	

E Position locking mechanism	
R	Rod side position locking
H	Head side position locking

F Switch model no.				
Lead wire	Lead wire	Contact	Indicator	Lead wire
T0H*	T0V*	Reed	1 color	2-wire
T5H*	T5V*		Without indicator light	
T8H*	T8V*		1 color	
T1H*	T1V*	Proximity	1 color	2-wire
T2H*	T2V*			
T3H*	T3V*		1 color (custom order)	3-wire
T3PH*	T3PV*			
T2YH*	T2YV*		2 color	2-wire
T3YH*	T3YV*			3-wire
T2YFH*	T2YFV*	2 color (w/o light for preventive maintenance output)	3-wire	
T3YFH*	T3YFV*		4 wire	
T2YMH*	T2YMV*	2 color (Light available for preventive maintenance output (1 color))	3-wire	
T3YMH*	T3YMV*		4 wire	
T2JH*	T2JV*	Off-delay type	2-wire	

* Lead wire length	
Blank	1 m (standard)
3	3 m (option)
5	5 m (option)

G Switch quantity	
R	One on rod end
H	One on head end
D	Two
T	Three

H Option	
F	Push-in joint (straight)
FE	Push-in joint (elbow)
M	Piston rod material (stainless steel)
P6	Copper and PTFE free
M0	Non-locking manual override (release bolt attached)
M1	Locking manual override

I Accessory	
I	Rod eye
Y	Rod clevis (pin and washer split pin attached)
B2	Clevis bracket (pin and snap ring attached)

Note on model no. selection

Note 1: The TA rod side position locking and TB head side position locking are not available.

Note 2: Refer to page 144 for min. stroke length with switch.

Note 3: Applicable tube O.D. of F; push-in joint (straight), FE; push-in joint (elbow) is φ 6.

Note 4: "I" and "Y" can not be selected at the same time.

Note 5: Refer to Ending 89 for custom specifications of rod end form.

Note 6: Refer to page 84 for variation and combinations of options.

Note 7: Up to three switches can be mounted. If more than four switches are required, switch mounting brackets for the extra switches must be prepared separately.

Note 8: If "M0" or "M1" is not selected for the "H" Options, only nonlocking manual override is available. The release bolt is not included.

<Example of model number>

CMK2-Q-00-20-25-R-T0H-R-M0Y

Model: Medium bore size cylinder position locking type

- A** Mounting style : Basic type
- B** Bore size : φ 20 mm
- C** Port thread type : Rc thread
- D** Stroke length : 25 mm
- E** Position locking mechanism : Rod side position locking
- F** Switch model no. : Reed T0H switch and lead wire 1 m
- G** Switch quantity : One on rod end
- H** Option : Non-locking manual override
- I** Accessory : Rod clevis

How to order switch

- Switch body + mounting bracket

CMK2 - **T0H** - **20**

Switch model no. (item ① on previous page) | Bore size (item ② on previous page)

- Only switch body

SW - **T0H**

Switch model no. (item ① on previous page)

- Mounting bracket

CMK2 - **T** - **20**

Bracket | Bore size (item ② on previous page)

How to order mounting bracket

Bore size (mm)	φ20	φ25	φ32	φ40
Mounting bracket				
Axial foot type (LB)	M1-LB-20	M1-LB-30	M1-LB-30	M1-LB-30
Flange (FA/FB)	M1-FA-20	M1-FA-30	M1-FA-30	M1-FA-30
Trunnion (TA/TB)	M1-TA-20	M1-TA-30	M1-TA-30	M1-TA-40
Eye bracket type (CA)	M1-CA-20	M1-CA-30	M1-CA-30	M1-CA-30
Clevis bracket type (CB)	M1-CB-20	M1-CB-30	M1-CB-30	M1-CB-30

Note 1: Mounting nut/toothed washer are attached to each mounting bracket.

Note 2: Two sets of "M1-LB-*" in the above table are required for the axial direction foot (double-sided).

SCP*2
CMK2
CMA2
SCM
SCG
SCA2
SCS
CKV2
CA/OV2
SSD
CAT
MDC2
MVC
SMD2
MSD*
FC*
STK
ULK*
JSK/M2
JSG
JSC3
USSD
USC
JSB3
LMB
STG
STS/L
LCS
LCG
LCM
LCT
LCY
STR2
UCA2
HCM
HCA
SRL2
SRG
SRM
SRT
MRL2
MRG2
SM-25
CAC3
UCAC
RCC2
MFC
SHC
GLC
Ending

Medium bore size cylinder
Standard type

Internal structure and parts list

SCP*2
CMK2
 CMA2
 SCM
 SCG
 SCA2
 SCS
 CKV2
 CA/OV2
 SSD
 CAT
 MDC2
 MVC
 SMD2
 MSD*
 FC*
 STK
 ULK*
 JSK/M2
 JSG
 JSC3
 USSD
 USC
 JSB3
 LMB
 STG
 STS/L
 LCS
 LCG
 LCM
 LCT
 LCY
 STR2
 UCA2
 HCM
 HCA
 SRL2
 SRG
 SRM
 SRT
 MRL2
 MRG2
 SM-25
 CAC3
 UCAC
 RCC2
 MFC
 SHC
 GLC
 Ending

●CMK2-Q (rod side position locking)

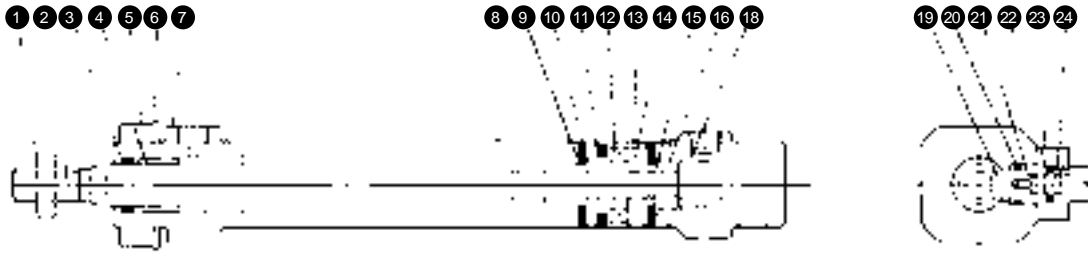

●CMK2-Q (head side position locking)

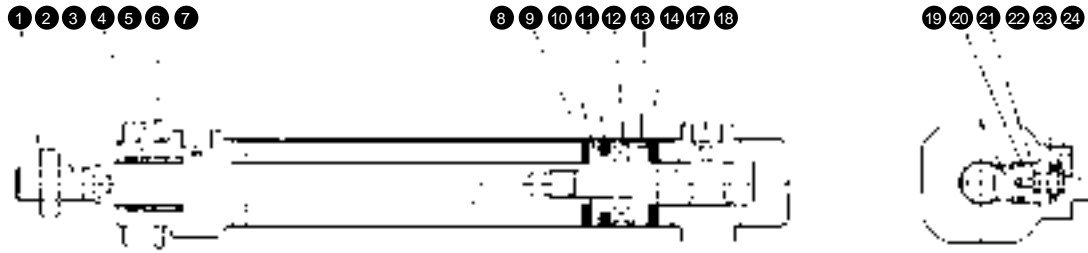

Note: This caulking type cannot be disassembled.

No.	Parts name	Material	Remarks	No.	Parts name	Material	Remarks
1	Rod nut	Steel	Zinc chromate	15	Spacer	Steel	Zinc chromate
2	Piston rod	$\phi 20, \phi 25$: Stainless steel $\phi 32, \phi 40$: Steel	Industrial chrome plating	16	Nut	Steel	Zinc chromate
3	Rod packing seal	Nitrile rubber		17	Sleeve	Stainless steel	
4	Bush	Dry bearing Oil impregnated bearing alloy	$\phi 20$ $\phi 25, \phi 32, \phi 40$ Note 1	18	Head cover	Aluminum alloy	
5	Nut	Steel	Zinc chromate	19	Stopper piston	Stainless steel	
6	Toothed washer	Steel	Zinc chromate	20	Piston packing seal (B)	Nitrile rubber	
7	Rod cover	Aluminum alloy		21	Spring	Steel	Paint
8	Cylinder tube	Stainless steel		22	Cushion rubber (B)	Urethane rubber	
9	Cushion rubber (A)	Urethane rubber		23	Stopper guard	Aluminum alloy	Chromate
10	Piston (A)	Aluminum alloy		24	Hexagon socket cap bolt	Alloy steel	Zinc chromate
11	Piston packing seal (A)	Nitrile rubber					
12	Magnet	Plastic					
13	Wear ring	Acetar resin					
14	Piston (B)	Aluminum alloy					

Note 1: For copper and PTFE free specifications, oil impregnated resin bearing is used.

(explanation of manual override)

●Non-locking manual override (option symbol: M0)

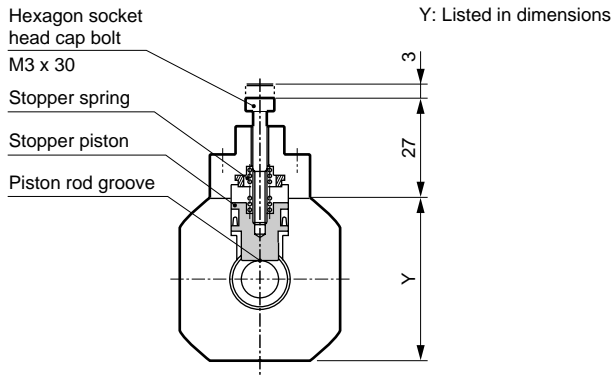

The stopper pin moves and the lock is released when the hexagon socket bolt (M3x30) is screwed into the stopper piston and the bolt is pulled up 3 mm with a force of 20 N or more during no-load horizontal installation or when the counter side port is pressurized. When the hand is released, if the stopper piston returns by the internal spring and enters the piston rod groove, the piston is locked.

●Locking manual override (option symbol: M1)

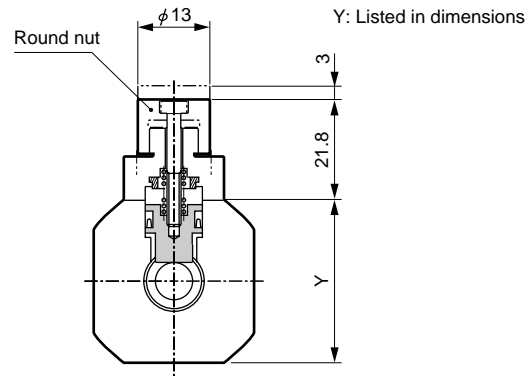

When the round nut is turned counterclockwise, the stopper pin moves and the lock is released. When the nut is turned clockwise to the lock position, the stopper piston returns. When it fits into the piston rod slot again, the piston is locked.

Dimensions

- T type basic type with switch (00)
(Rod side position locking)

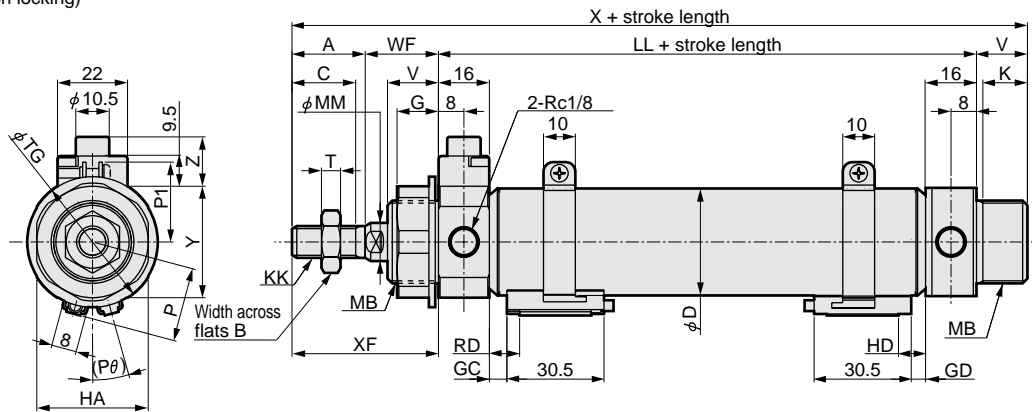

(Head side position locking)

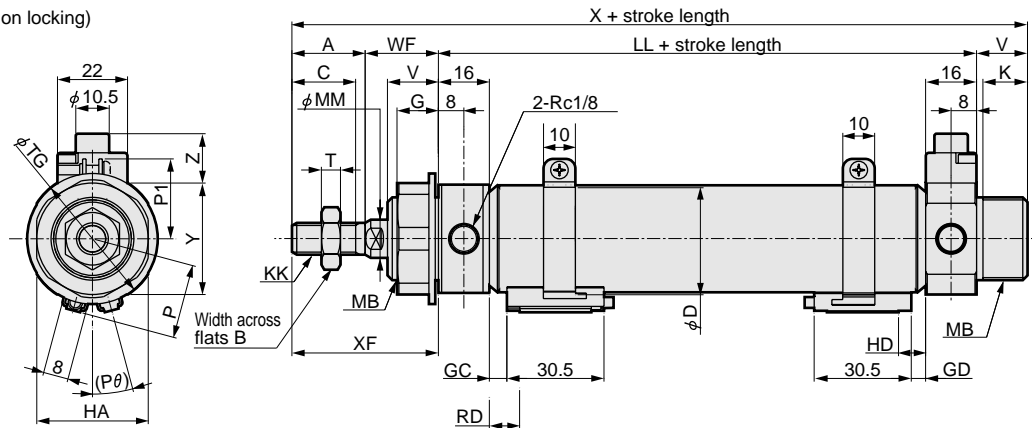

Note 1: Refer to the drawing for "Explanation of manual override" on the previous page for dimensions of the type with manual override.

Note 2: Refer to page 188 for the HD, RD, and projecting dimensions of the T1* and T8* switches and 2-color indicator switch with preventive maintenance output.

Note 3: Refer to page 190 for dimensions of accessories.

RD: Rod side max. sensitive position
HD: Head side max. sensitive position

Symbol	Basic type (00) basic dimensions											
Bore size (mm)	A	B	C	D	G	HA	K	KK	LL	MB	MM	
φ20	20	13	18	21.4	(11)	26	12	M8 x 1.0	66	M18 x 1.5	10	
φ25	23	17	20	26.4	(13)	35	14	M10 x 1.25	69	M26 x 1.5	12	
φ32	23	17	20	33.6	(13)	35	14	M10 x 1.25	69	M26 x 1.5	12	
φ40	25	19	22	41.6	(13)	35	14	M12 x 1.5	73	M26 x 1.5	14	
Symbol										With switch		
Bore size (mm)	T	TG	V	WF	X	XF	Y	Z		GC	GD	RD
φ20	5	29	14	24	124	44	31	15.5		4.0	3.0	8.0
φ25	6	41	16	23	131	46	35	15.5		5.5	4.5	9.5
φ32	6	41	16	23	131	46	35	15.5		5.5	4.5	9.5
φ40	7	41	16	23	137	48	43	15.5		7.0	6.5	11.5
Symbol												
Bore size (mm)	HD	P	P1	(Pθ)°								
φ20	7.0	17.3	19.5	22								
φ25	8.5	19.8	22.0	18								
φ32	8.5	24.3	25.5	15								
φ40	10.5	28.3	29.5	12								

Dimensions of each mounting type are same as standard type. Refer to pages 96 to 101.

SCP*2
CMK2
CMA2
SCM
SCG
SCA2
SCS
CKV2
CA/OV2
SSD
CAT
MDC2
MVC
SMD2
MSD*
FC*
STK
ULK*
JSK/M2
JSG
JSC3
USSD
USC
JSB3
LMB
STG
STS/L
LCS
LCG
LCM
LCT
LCY
STR2
UCA2
HCM
HCA
SRL2
SRG
SRM
SRT
MRL2
MRG2
SM-25
CAC3
UCAC
RCC2
MFC
SHC
GLC
Ending

Medium bore size cylinder
Standard type

SCP*2
CMK2
 CMA2
 SCM
 SCG
 SCA2
 SCS
 CKV2
 CA/OV2
 SSD
 CAT
 MDC2
 MVC
 SMD2
 MSD*
 FC*
 STK
 ULK*
 JSK/M2
 JSG
 JSC3
 USSD
 USC
 JSB3
 LMB
 STG
 STS/L
 LCS
 LCG
 LCM
 LCT
 LCY
 STR2
 UCA2
 HCM
 HCA
 SRL2
 SRG
 SRM
 SRT
 MRL2
 MRG2
 SM-25
 CAC3
 UCAC
 RCC2
 MFC
 SHC
 GLC
 Ending

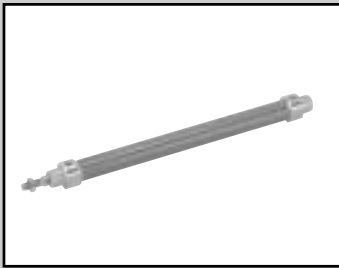

Medium bore size cylinder
 Double acting /fine speed type

CMK2-F Series

● Bore size: ϕ 20, ϕ 25, ϕ 32, ϕ 40

JIS symbol ● Double acting cylinder single rod type

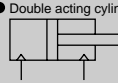

Specifications

Descriptions	CMK2-F			
Bore size mm	ϕ 20	ϕ 25	ϕ 32	ϕ 40
Actuation	Double acting			
Working fluid	Compressed air			
Max. working pressure MPa	1.0			
Min. working pressure MPa	0.1			
Withstanding pressure MPa	1.6			
Ambient temperature °C	5 to 60			
Port size	Rc1/8			
Stroke tolerance mm	$^{+2.0}_0$ (up to 200), $^{+2.4}_0$ (over 200)			
Working piston speed mm/s	1 to 200			
Cushion	Rubber cushion			
Lubrication	Must be oil free			
Allowable energy absorption J	0.166	0.308	0.424	0.639

Stroke length

Model no.	Bore size (mm)	Standard stroke length (mm)	Max. stroke length (mm)	Min. stroke length (mm)
CMK2-F	ϕ 20, ϕ 25, ϕ 32, ϕ 40	25, 50, 75, 100, 150, 200, 250, 300	750	5

Note 1: Custom stroke length is available per 1 mm increment.

Note 2: For single foot type (LS type), maximum stroke length is 50 mm.

Min. stroke length of type with switch

(Unit: mm)

Switch quantity Bore size (mm)	1			2				3							
	Proximity		Reed	Proximity		Reed		Proximity		Reed					
	T2, T3	T1, T*Y*	T0, T5	T8	T2, T3	T1, T*Y*	T0, T5	T8	T2, T3	T1, T*Y*	T0, T5	T8			
ϕ 20	10		25			35		25		35		50		55	
ϕ 25	10		25			35		25		35		50		55	
ϕ 32	10		25			35		25		35		50		55	
ϕ 40	10		25			35		25		35		50		55	

Note 1: Up to three switches can be mounted.

Switch specifications

- 1 color/2 color indicator

* The T0/T5 switch can be used with 220 VAC. Contact CKD for working conditions.

Descriptions	Proximity 2-wire			Proximity 3-wire			Reed 2-wire							
	T1H/T1V	T2H/T2V/ T2JH/T2JV	T2YH/T2YV	T3H/T3V	T3PH/T3PV (Custom order)	T3YH/T3YV	TOH/TOV		T5H/T5V		T8H/T8V			
Applications	Programmable controller Relay, small solenoid valve	Programmable controller dedicated		Programmable controller, relay			Programmable controller, relay		Programmable controller, relay, IC circuit (w/o light), serial connection		Programmable controller, relay			
Output method	-			NPN output	PNP output	NPN output	-							
Power voltage	-			10 to 28 VDC			-							
Load voltage	85 to 265 VAC	10 to 30 VDC		30 VDC or less			12/24 VDC	110 VAC	5/12/24 VDC	110 VAC	12/24 VDC	110 VAC	220 VAC	
Load current	5 to 100 mA	5 to 20 mA (Note 1)		100 mA or less			50 mA or less	5 to 50 mA	7 to 20 mA	50 mA or less	20 mA or less	5 to 50 mA	7 to 20 mA	7 to 10 mA
Light	LED (ON lighting)	LED (ON lighting)	Red/green LED (ON lighting)	LED (ON lighting)	Green LED (ON lighting)	Red/Green LED (ON lighting)	LED (ON lighting)		Without indicator light		LED (ON lighting)			
Leakage current	1 mA or less with 100 VAC 2 mA or less with 200 VAC	1 mA or less		10 μA or less			0 mA							

- With preventive maintenance output

Descriptions	Proximity 3-wire		Proximity 4-wire		Proximity 3-wire		Proximity 4-wire		
	T2YFH/V		T3YFH/V		T2YMH/V		T3YMH/V		
Applications	Programmable controller dedicated		Programmable controller, relay		Programmable controller dedicated		Programmable controller, relay		
Output method	NPN output								
Light	Red/Green LED (ON lighting)								
	Installation position adjustment	-						Yellow LED (ON lighting)	
Regular Output section	Power voltage	-		10 to 28 VDC		-		10 to 28 VDC	
	Load voltage	10 to 30 VDC		30 VDC or less		10 to 30 VDC		30 VDC or less	
	Load current	5 to 20 mA		50 mA or less		5 to 20 mA		50 mA or less	
	Leakage current	1 mA or less		10 μA or less		1.2 mA or less		10 μA or less	
Preventive maintenance Output section	Load voltage	30 VDC or less							
	Load current	20 mA or less		50 mA or less		5 to 20 mA or less		50 mA or less	
	Leakage current	10 μA or less							

Note 1: Refer to Ending 1 for other switches.

Note 2: The above maximum load current of 20 mA applies at 25 °C. If the switch's working ambient temperature exceeds 25 °C, the load current will be lower than 20 mA. (5 to 10 mA when 60 °C)

Cylinder weight

(Unit: kg)

Descriptions/mounting style	Product weight when stroke length (S) = 0 mm								Switch weight	Switch rail + band weight	Additional weight per S = 10 mm
	Basic (00)	Axial foot (LB)	Axial foot (LS)	Flange (FA/FB)	Eye bracket (CA)	Clevis (CC)	Clevis bracket (CB)	Trunnion (TA/TB)	Grommet		
φ 20	0.17	0.32	0.25	0.23	0.32	0.18	0.32	0.22	0.018	0.005	0.01
φ 25	0.26	0.52	0.39	0.41	0.50	0.26	0.50	0.36	0.018	0.005	0.01
φ 32	0.30	0.56	0.43	0.45	0.54	0.30	0.54	0.40	0.018	0.009	0.02
φ 40	0.48	0.74	0.61	0.63	0.72	0.50	0.72	0.64	0.018	0.009	0.02

(E.g.)

Product weight of CMK2-F-FA-32-50-TOH-D

When S = 0 mm, product weight is 0.45 kg

Additional weight at S = 50 mm is additional weight at S = 10 mm $0.02 \times \frac{\text{Product stroke length (50)}}{10} = 0.10$ kg

Weight of two switches is 0.036 kg

Weight of switch rail and two bands is 0.018 kg

Product weight is 0.45 kg + 0.1 kg + 0.036 kg + 0.018 kg = 0.604 kg

SCP*2
CMK2
CMA2
SCM
SCG
SCA2
SCS
CKV2
CA/OV2
SSD
CAT
MDC2
MVC
SMD2
MSD*
FC*
STK
ULK*
JSK/M2
JSG
JSC3
USSD
USC
JSB3
LMB
STG
STS/L
LCS
LCG
LCM
LCT
LCY
STR2
UCA2
HCM
HCA
SRL2
SRG
SRM
SRT
MRL2
MRG2
SM-25
CAC3
UCAC
RCC2
MFC
SHC
GLC
Ending

Medium bore size cylinder
Standard type

How to order

● Without switch

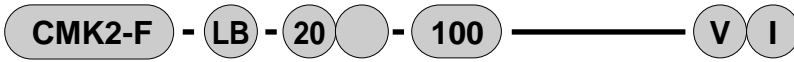

● With switch

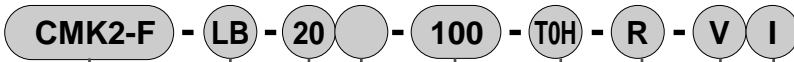

Model no.

A Mounting style
Note 1

B Bore size

C Port thread type

D Stroke length

E Switch model no.

F Switch quantity
Note 6

G Option

H Accessory
Note 3

Symbol	Descriptions
A Mounting style	
00	Basic type
LB	Both sides axial foot type
LS	Single axial foot type (rod side)
FA	Rod side flange type
FB	Head side flange type
CA	Eye bracket type
CC	Fixed eye
CB	Clevis bracket type (pin and washer split pin attached)
TA	Rod side trunnion type
TB	Head side trunnion type

B Bore size (mm)	
20	φ20
25	φ25
32	φ32
40	φ40

C Port thread type	
Blank	Rc thread
NN	NPT thread (custom order)
GN	G thread (custom order)

D Stroke length (mm)		
Bore size	Stroke length Note 2	Custom stroke length
φ20	5 to 750	By 1 mm increment
φ25	5 to 750	
φ32	5 to 750	
φ40	5 to 750	

E Switch model no.				
Lead wire Straight type	Lead wire L type	Contact	Indicator	
			Reed	Proximity
T0H*	T0V*	Reed	1 color	2-wire
T5H*	T5V*		Without indicator light	
T8H*	T8V*		1 color	
T1H*	T1V*	Proximity	1 color	2-wire
T2H*	T2V*		1 color (custom order)	3-wire
T3H*	T3V*			2 color
T3PH*	T3PV*	Proximity	2 color (w/o light for preventive maintenance output)	3-wire
T2YH*	T2YV*		2 color (Light available for preventive maintenance output (1 color))	4 wire
T3YH*	T3YV*			3-wire
T2YFH*	T2YFV*		4 wire	
T3YFH*	T3YFV*	Off-delay type	3-wire	
T2YMH*	T2YMV*		4 wire	
T3YMH*	T3YMV*	4 wire		
T2JH*	T2JV*	2-wire		

* Lead wire length	
Blank	1 m (standard)
3	3 m (option)
5	5 m (option)

F Switch quantity	
R	One on rod side
H	One on head side
D	Two
T	Three

G Option	
M	Piston rod material (stainless steel)
V	Boss cut off

H Accessory	
I	Rod eye
Y	Rod clevis (pin and washer split pin attached)
B2	Clevis bracket (pin and snap ring attached)

Note on selection guide

Note 1: The maximum stroke of the single-end foot type (LS type) is 50 mm.

Note 2: Refer to page 150 for min. stroke length with switch.

Note 3: "I" and "Y" can not be selected at the same time.

Note 4: Refer to Ending 89 for custom specifications of rod end form.

Note 5: Refer to page 84 for variation and combinations of options.

Note 6: Up to three switches can be mounted. If more than four switches are required, switch mounting brackets for the extra switches must be prepared separately.

<Example of model number>

CMK2-F-LB-20-25-T0H-R-VI

Model: Medium bore size cylinder fine speed type

- A Mounting style : Both sides axial foot type
- B Bore size : φ20 mm
- C Port thread type : Rc thread
- D Stroke length : 25 mm
- E Switch model no. : Reed switch T0H and lead wire 1 m
- F Switch quantity : One on rod end
- G Option : Boss cut off
- H Accessory : Rod eye

How to order switch

- Switch body + mounting bracket

CMK2 - **T0H** - **20**

Switch model no. (item ③ on previous page) | Bore size (item ④ on previous page)

- Only switch body

SW - **T0H**

Switch model no. (item ③ on previous page)

- Mounting bracket

CMK2 - **T** - **20**

Bracket | Bore size (item ④ on previous page)

How to order mounting bracket

Bore size (mm)	φ 20	φ 25	φ 32	φ 40
Mounting bracket				
Axial foot type (LB/LS)	M1-LB-20	M1-LB-30	M1-LB-30	M1-LB-30
Flange (FA/FB)	M1-FA-20	M1-FA-30	M1-FA-30	M1-FA-30
Trunnion (TA/TB)	M1-TA-20	M1-TA-30	M1-TA-30	M1-TA-40
Eye bracket type (CA)	M1-CA-20	M1-CA-30	M1-CA-30	M1-CA-30
Clevis bracket type (CB)	M1-CB-20	M1-CB-30	M1-CB-30	M1-CB-30

Note 1: Mounting nut/toothed washer are attached to each mounting bracket.

Note 2: Two sets of "M1-LB-*1" in the above table are required for the axial direction foot (double-sided).

Dimensions

It is the same as the double acting/single rod type CMK2 Series. Refer to pages 95 to 101.

Technical data

Refer to page 806 for technical data of a measuring method.

SCP*2
CMK2
CMA2
SCM
SCG
SCA2
SCS
CKV2
CA/OV2
SSD
CAT
MDC2
MVC
SMD2
MSD*
FC*
STK
ULK*
JSK/M2
JSG
JSC3
USSD
USC
JSB3
LMB
STG
STS/L
LCS
LCG
LCM
LCT
LCY
STR2
UCA2
HCM
HCA
SRL2
SRG
SRM
SRT
MRL2
MRG2
SM-25
CAC3
UCAC
RCC2
MFC
SHC
GLC
Ending

Medium bore size cylinder
Standard type

SCP*2
CMK2
 CMA2
 SCM
 SCG
 SCA2
 SCS
 CKV2
 CA/OV2
 SSD
 CAT
 MDC2
 MVC
 SMD2
 MSD*
 FC*
 STK
 ULK*
 JSK/M2
 JSG
 JSC3
 USSD
 USC
 JSB3
 LMB
 STG
 STS/L
 LCS
 LCG
 LCM
 LCT
 LCY
 STR2
 UCA2
 HCM
 HCA
 SRL2
 SRG
 SRM
 SRT
 MRL2
 MRG2
 SM-25
 CAC3
 UCAC
 RCC2
 MFC
 SHC
 GLC
 Ending

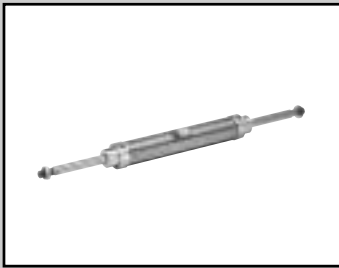

Medium bore size cylinder
 Double acting double rod type

CMK2-D Series

● Bore size: ϕ 20, ϕ 25, ϕ 32, ϕ 40

JIS symbol ● Double acting cylinder double rod type

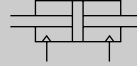

Specifications

Descriptions		CMK2-D			
Bore size	mm	ϕ 20	ϕ 25	ϕ 32	ϕ 40
Actuation		Double acting double rod type			
Working fluid		Compressed air			
Max. working pressure	MPa	1.0			
Min. working pressure	MPa	0.15			
Withstanding pressure	MPa	1.6			
Ambient temperature	°C	-10 to 60 (no freezing)			
Port size		Rc1/8			
Stroke tolerance	mm	$^{+2.0}_0$ (up to 200), $^{+2.4}_0$ (over 200)			
Working piston speed	mm/s	50 to 500			
Cushion		Rubber cushion			
Lubrication		Not required (when lubricating, use turbine oil Class 1 ISO VG32.)			
Allowable energy absorption	J	0.166	0.308	0.424	0.639

Stroke length

Bore size (mm)	Standard stroke length (mm)	Max. stroke length (mm)	Min. stroke length (mm)
ϕ 20	25, 50, 75, 100,	500	5
ϕ 25		500	
ϕ 32	150, 200, 250,	480	
ϕ 40	300	450	

Note 1: Custom stroke length is available per 1 mm increment.
 Note 2: For single foot type (LS type), maximum stroke length is 50 mm.
 Note 3: For bellows "J" type, stroke length should be longer than 25 mm.
 Consult with CKD when stroke length is shorter than 25 mm.

Min. stroke length of type with switch

(Unit: mm)

Switch quantity	1				2				3			
	Proximity		Reed		Proximity		Reed		Proximity		Reed	
	T2, T3	T1, T*Y*	T0, T5	T8	T2, T3	T1, T*Y*	T0, T5	T8	T2, T3	T1, T*Y*	T0, T5	T8
Bore size (mm)												
ϕ 20	10				25	35	25	35	50	55	50	55
ϕ 25	10				25	35	25	35	50	55	50	55
ϕ 32	10				25	35	25	35	50	55	50	55
ϕ 40	10				25	35	25	35	50	55	50	55

Note 1: Up to three switches can be mounted.

- SCP*2
- CMK2**
- CMA2
- SCM
- SCG
- SCA2
- SCS
- CKV2
- CA/OV2
- SSD
- CAT
- MDC2
- MVC
- SMD2
- MSD*
- FC*
- STK
- ULK*
- JSK/M2
- JSG
- JSC3
- USSD
- USC
- JSB3
- LMB
- STG
- STS/L
- LCS
- LCG
- LCM
- LCT
- LCY
- STR2
- UCA2
- HCM
- HCA
- SRL2
- SRG
- SRM
- SRT
- MRL2
- MRG2
- SM-25
- CAC3
- UCAC
- RCC2
- MFC
- SHC
- GLC

Switch specifications

● 1 color/2 color indicator

* The T0/T5 switch can be used with 220 VAC. Contact CKD for working conditions.

Descriptions	Proximity 2-wire			Proximity 3-wire			Reed 2-wire						
	T1H/T1V	T2H/T2V/ T2JH/T2JV	T2YH/T2YV	T3H/T3V	T3PH/T3PV (Custom order)	T3YH/T3YV	TOH/TOV		T5H/T5V		T8H/T8V		
Applications	Programmable controller Relay, small solenoid valve	Programmable controller dedicated		Programmable controller, relay			Programmable controller, relay	Programmable controller, relay, IC circuit (w/o light) serial connection		Programmable controller, relay			
Output method	-			NPN output	PNP output	NPN output	-						
Power voltage	-			10 to 28 VDC			-						
Load voltage	85 to 265 VAC	10 to 30 VDC		30 VDC or less			12/24 VDC	110 VAC	5/12/24 VDC	110 VAC	12/24 VDC	110 VAC	220 VAC
Load current	5 to 100 mA	5 to 20 mA (Note 1)		100 mA or less			50 mA or less	5 to 50 mA	7 to 20 mA	50 mA or less	20 mA or less	5 to 50 mA	7 to 20 mA
Light	LED (ON lighting)	LED (ON lighting)	Red/green LED (ON lighting)	LED (ON lighting)	Green LED (ON lighting)	Red/Green LED (ON lighting)	LED (ON lighting)	Without indicator light		LED (ON lighting)			
Leakage current	1 mA or less with 100 VAC 2 mA or less with 200 VAC	1 mA or less		10 μ A or less			0 mA						

● With preventive maintenance output

Descriptions	Proximity 3-wire		Proximity 4-wire		Proximity 3-wire		Proximity 4-wire	
	T2YFH/V		T3YFH/V		T2YMH/V		T3YMH/V	
Applications	Programmable controller dedicated		Programmable controller, relay		Programmable controller dedicated		Programmable controller, relay	
Output method	NPN output							
Light	Red/Green LED (ON lighting)							
	Installation position adjustment		-		Yellow LED (ON lighting)			
Regular Output section	Power voltage		10 to 28 VDC		-		10 to 28 VDC	
	Load voltage		30 VDC or less		10 to 30 VDC		30 VDC or less	
	Load current		50 mA or less		5 to 20 mA		50 mA or less	
	Leakage current		10 μ A or less		1.2 mA or less		10 μ A or less	
Preventive maintenance Output section	30 VDC or less							
	Load voltage		50 mA or less		5 to 20 mA or less		50 mA or less	
	Leakage current		10 μ A or less					

Note 1: Refer to Ending 1 for other switches.

Note 2: The above maximum load current of 20 mA applies at 25 °C. If the switch's working ambient temperature exceeds 25 °C, the load current will be lower than 20 mA. (5 to 10 mA when 60 °C)

Cylinder weight

(Unit: kg)

Descriptions/mounting style	Product weight when stroke length (S) = 0 mm					Switch weight	Switch rail + band weight	Additional weight per S = 10 mm
	Basic type (00)	Axial foot type (LB)	Axial foot type (LS)	Flange type (FA/FB)	Trunnion type (TA/TB)	Grommet		
φ20	0.21	0.36	0.29	0.27	0.26	0.018	0.005	0.02
φ25	0.32	0.58	0.45	0.47	0.42	0.018	0.005	0.02
φ32	0.36	0.62	0.49	0.51	0.46	0.018	0.009	0.03
φ40	0.57	0.83	0.70	0.72	0.73	0.018	0.009	0.03

Medium bore size cylinder Standard type

How to order

Without switch

CMK2-D - 00 - 20 - 100 - J I

With switch

CMK2-D - 00 - 20 - 100 - T0H - R - J I

A Mounting style
Note 1

B Bore size

C Port thread type

D Stroke length
Note 2

E Switch model no.

F Switch quantity
Note 9

G Option
Note 4, Note 5, Note 6

H Accessory

Note on model no. selection

Note 1: The maximum stroke of the single-end foot type (LS type) is 50 mm.

Note 2: Maximum stroke length is 300 mm for types with bellows.

Note 3: Refer to page 154 for min. stroke length with switch.

Note 4: Applicable tube O.D. of F; push-in joint (straight), FE; push-in joint (elbow) is ϕ 6.

Note 5: For bellows "J" type, stroke length should be longer than 25 mm. Consult with CKD when stroke length is shorter than 25 mm.

Note 6: Instantaneous maximum temperature is the temperature when spark and spatter etc. instantaneously contacts to bellows.

Note 7: Refer to Ending 89 for the custom order specifications of rod end form.

Note 8: Refer to page 84 for variation and combinations of options.

Note 9: Up to three switches can be mounted. If more than four switches are required, switch mounting brackets for the extra switches must be prepared separately.

<Example of model number>

CMK2-D-00-20-100-T0H-R-JI

Model: Medium bore size cylinder double acting double rod type

A Mounting style : Basic type

B Bore size : ϕ 20 mm

C Port thread type : Rc thread

D Stroke length : 100 mm

E Switch model no. : Reed T0H switch and lead wire 1 m

F Switch quantity : One on rod end

G Option : Bellows, max. ambient temperature 100 °C or instantaneous max. temperature 200 °C

H Accessory : Rod eye

Symbol	Descriptions
A Mounting style	
00	Basic type
LB	Axial foot type (both sides)
LS	Axial foot type (single)
FA	Rod side flange type
TA	Rod side trunnion type

B Bore size (mm)	
20	ϕ 20
25	ϕ 25
32	ϕ 32
40	ϕ 40

C Port thread type	
Blank	Rc thread
NN	NPT thread (custom order)
GN	G thread (custom order)

D Stroke length (mm)		
Bore size	Stroke length Note 3	Custom stroke length
ϕ 20	5 to 500	By 1 mm increment
ϕ 25	5 to 500	
ϕ 32	5 to 480	
ϕ 40	5 to 450	

E Switch model no.				
Lead wire Straight type	Lead wire L type	Contact	Indicator	Lead wire
T0H*	T0V*	Reed	1 color	2-wire
T5H*	T5V*		Without indicator light	
T8H*	T8V*		1 color	
T1H*	T1V*	Proximity	1 color	2-wire
T2H*	T2V*			
T3H*	T3V*		1 color (custom order)	3-wire
T3PH*	T3PV*			
T2YH*	T2YV*			
T3YH*	T3YV*		2 color	3-wire
T2YFH*	T2YFV*			
T3YFH*	T3YFV*	2 color (w/o light for preventive maintenance output)	3-wire	
T2YMH*	T2YMV*			
T3YMH*	T3YMV*	2 color (Light available for preventive maintenance output (1 color))	4 wire	
T2JH*	T2JV*			
Off-delay type 2-wire				

* Lead wire length	
Blank	1 m (standard)
3	3 m (option)
5	5 m (option)

F Switch quantity	
R	One on rod end
H	One on head end
D	Two
T	Three

G Option			
		Max. ambient	Max. instantaneous
J	Bellows	100 °C	200 °C
L	Bellows	250 °C	400 °C
F	Push-in joint (straight)		
FE	Push-in joint (elbow)		
M	Piston rod material (stainless steel)		
P6	Copper and PTFE free		

H Accessory	
I	Rod eye
Y	Rod clevis (pin and washer split pin attached)
B2	Clevis bracket (pin and snap ring attached)

How to order switch

- Switch body + mounting bracket

CMK2 - **T0H** - **20**

Bore size (item ③ on previous page)

Switch model no. (item ① on previous page)

- Only switch body

SW - **T0H**

Switch model no. (item ① on previous page)

- Mounting bracket

CMK2 - **T** - **20**

Bore size (item ③ on previous page)

Bracket

How to order mounting bracket

Bore size (mm)	$\phi 20$	$\phi 25$	$\phi 32$	$\phi 40$
Mounting bracket				
Axial foot type (LB/LS)	M1-LB-20	M1-LB-30	M1-LB-30	M1-LB-30
Flange (FA)	M1-FA-20	M1-FA-30	M1-FA-30	M1-FA-30
Trunnion (TA)	M1-TA-20	M1-TA-30	M1-TA-30	M1-TA-40

Note 1: Mounting nut/toothed washer are attached to each mounting bracket.

Note 2: Two sets of "M1-LB-*" in the above table are required for the axial direction foot (double-sided).

SCP*2
CMK2
CMA2
SCM
SCG
SCA2
SCS
CKV2
CA/OV2
SSD
CAT
MDC2
MVC
SMD2
MSD*
FC*
STK
ULK*
JSK/M2
JSG
JSC3
USSD
USC
JSB3
LMB
STG
STS/L
LCS
LCG
LCM
LCT
LCY
STR2
UCA2
HCM
HCA
SRL2
SRG
SRM
SRT
MRL2
MRG2
SM-25
CAC3
UCAC
RCC2
MFC
SHC
GLC
Ending

Medium bore size cylinder
Standard type

Internal structure and parts list

SCP*2
CMK2
CMA2
SCM
SCG
SCA2
SCS
CKV2
CA/OV2
SSD
CAT
MDC2
MVC
SMD2
MSD*
FC*
STK
ULK*
JSK/M2
JSG
JSC3
USSD
USC
JSB3
LMB
STG
STS/L
LCS
LCG
LCM
LCT
LCY
STR2
UCA2
HCM
HCA
SRL2
SRG
SRM
SRT
MRL2
MRG2
SM-25
CAC3
UCAC
RCC2
MFC
SHC
GLC
Ending

● CMK2-D

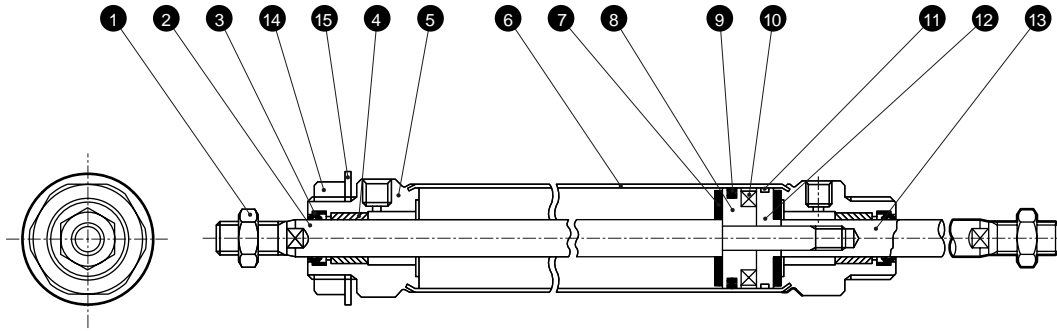

● Note: This caulking type cannot be disassembled.

No.	Parts name	Material	Remarks	No.	Parts name	Material	Remarks
1	Rod nut	Steel	Zinc chromate	11	Wear ring	Polyacetal	
2	Piston rod A	$\phi 20, \phi 25$: Stainless steel $\phi 32, \phi 40$: Carbon steel	Industrial chrome plating	12	Piston B	Aluminum alloy	
3	Rod packing seal	Nitrile rubber		13	Piston rod B	$\phi 20, \phi 25$: Stainless steel $\phi 32, \phi 40$: Carbon steel	Industrial chrome plating
4	Bush	$\phi 20$: Dry bearing $\phi 25, \phi 32, \phi 40$: Copper	Note 1	14	Nut	Steel	Zinc chromate
5	Rod cover	Aluminum alloy		15	The toothed washer	Steel	Zinc chromate
6	Cylinder tube	Stainless steel					
7	Cushion rubber	Urethane rubber					
8	Piston A	Aluminum alloy					
9	Piston packing seal	Nitrile rubber					
10	Magnet	Plastic					

Note 1: For copper and PTFE free specifications, oil impregnated resin bearing is used.

Dimensions

- Basic type (00)
- T type with switch

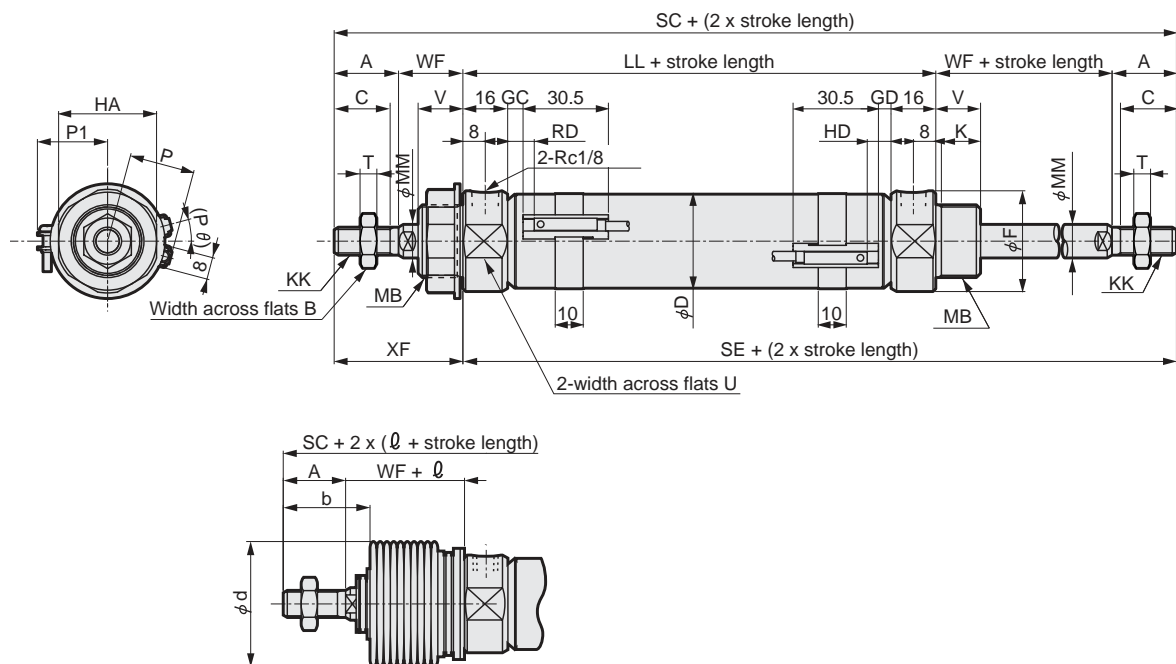

(with bellows)

Note 1: Refer to page 188 for the HD, RD, and projecting dimensions of the T1* and T8* switches and 2-color indicator switch with preventive maintenance output.

Note 2: For ℓ dimensions, round up decimal point or less.

Note 3: The position of the width across flats for catching the wrench on the left and right is not specified.

Note 4: Refer to page 190 for dimensions of accessories.

RD: Rod side max. sensitive position
HD: Head side max. sensitive position

Symbol	A	B	C	D	F	HA	K	KK	LL	MB	MM	T	U	V	WF	XF	SC	SE	With switch	
																			GC	GD
$\phi 20$	20	13	18	21.4	28	26	12	M8 x 1.0	66	M18 x 1.5	10	5	24	14	24	44	154	110	4.0	3.0
$\phi 25$	23	17	20	26.4	32	35	14	M10 x 1.25	69	M26 x 1.5	12	6	30	16	23	46	161	115	5.5	4.5
$\phi 32$	23	17	20	33.6	36	35	14	M10 x 1.25	69	M26 x 1.5	12	6	34	16	23	46	161	115	5.5	4.5
$\phi 40$	25	19	22	41.6	45	35	14	M12 x 1.5	73	M26 x 1.5	14	7	43	16	23	48	169	121	7.0	6.5
Symbol	With bellows																			
Bore size (mm)	RD	HD	P	P1	(P θ)°	b	d	ℓ												
$\phi 20$	8.0	7.0	17.3	19.5	22	30	30	(stroke length/3) + 6												
$\phi 25$	9.5	8.5	19.8	22.0	18	32	46	(stroke length/3.25) + 7												
$\phi 32$	9.5	8.5	24.3	25.5	15	32	46	(stroke length/3.25) + 7												
$\phi 40$	11.5	10.5	28.3	29.5	12	34	46	(stroke length/3.25) + 7												

Dimensions of each mounting type are same as standard type. Refer to pages 96 to 101.

SCP*2
CMK2
CMA2
SCM
SCG
SCA2
SCS
CKV2
CA/OV2
SSD
CAT
MDC2
MVC
SMD2
MSD*
FC*
STK
ULK*
JSK/M2
JSG
JSC3
USSD
USC
JSB3
LMB
STG
STS/L
LCS
LCG
LCM
LCT
LCY
STR2
UCA2
HCM
HCA
SRL2
SRG
SRM
SRT
MRL2
MRG2
SM-25
CAC3
UCAC
RCC2
MFC
SHC
GLC
Ending

Medium bore size cylinder
Standard type

SCP*2
CMK2
 CMA2
 SCM
 SCG
 SCA2
 SCS
 CKV2
 CA/OV2
 SSD
 CAT
 MDC2
 MVC
 SMD2
 MSD*
 FC*
 STK
 ULK*
 JSK/M2
 JSG
 JSC3
 USSD
 USC
 JSB3
 LMB
 STG
 STS/L
 LCS
 LCG
 LCM
 LCT
 LCY
 STR2
 UCA2
 HCM
 HCA
 SRL2
 SRG
 SRM
 SRT
 MRL2
 MRG2
 SM-25
 CAC3
 UCAC
 RCC2
 MFC
 SHC
 GLC
 Ending

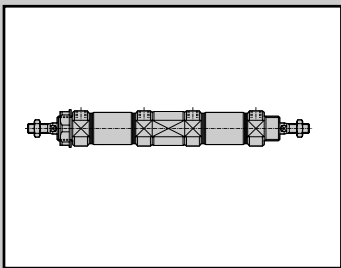

Medium bore size cylinder
 Double acting back to back type

CMK2-B Series

● Bore size: ϕ 20, ϕ 25, ϕ 32, ϕ 40

JIS symbol ● Double acting cylinder back to back type

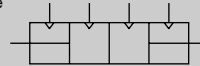

Specifications

Descriptions		CMK2-B			
Bore size	mm	ϕ 20	ϕ 25	ϕ 32	ϕ 40
Actuation		Double acting back to back type			
Working fluid		Compressed air			
Max. working pressure	MPa	1.0			
Min. working pressure	MPa	0.1			
Withstanding pressure	MPa	1.6			
Ambient temperature	°C	-10 to 60 (no freezing)			
Port size		Rc1/8			
Stroke tolerance	mm	$^{+2.0}_0$ (up to 200), $^{+2.4}_0$ (over 200)			
Working piston speed	mm/s	50 to 500			
Cushion		Rubber cushion			
Lubrication		Not required (when lubricating, use turbine oil Class 1 ISO VG32.)			
Allowable energy absorption	J	0.166	0.308	0.424	0.639

Stroke length

Bore size (mm)	Standard stroke length (mm)	Max. stroke length (mm)	Min. stroke length (mm)
ϕ 20	25, 50, 75, 100, 150, 200, 250, 300	750	5
ϕ 25			
ϕ 32			
ϕ 40			

Note 1: Custom stroke length is available per 1 mm increment.
 Note 2: For bellows "J" type, stroke length should be longer than 25 mm.
 Consult with CKD when stroke length is shorter than 25 mm.

Min. stroke length of type with switch

(Unit: mm)

Switch quantity	1				2				3											
	Proximity		Reed		Proximity		Reed		Proximity		Reed									
	T2, T3	T1, T*Y*	T0, T5	T8	T2, T3	T1, T*Y*	T0, T5	T8	T2, T3	T1, T*Y*	T0, T5	T8								
Bore size (mm)																				
ϕ 20	10				25		35		25		35		50		55		50		55	
ϕ 25	10				25		35		25		35		50		55		50		55	
ϕ 32	10				25		35		25		35		50		55		50		55	
ϕ 40	10				25		35		25		35		50		55		50		55	

Note 1: Up to three switches can be mounted.

Switch specifications

- 1 color/2 color indicator

* The T0/T5 switch can be used with 220 VAC. Contact CKD for working conditions.

Descriptions	Proximity 2-wire			Proximity 3-wire			Reed 2-wire							
	T1H/T1V	T2H/T2V/ T2JH/T2JV	T2YH/T2YV	T3H/T3V	T3PH/T3PV (Custom order)	T3YH/T3YV	TOH/TOV		T5H/T5V		T8H/T8V			
Applications	Programmable controller Relay, small solenoid valve	Programmable controller dedicated		Programmable controller, relay			Programmable controller, relay		Programmable controller, relay, IC circuit (w/o light), serial connection		Programmable controller, relay			
Output method	-			NPN output	PNP output	NPN output	-							
Power voltage	-			10 to 28 VDC			-							
Load voltage	85 to 265 VAC	10 to 30 VDC		30 VDC or less			12/24 VDC	110 VAC	5/12/24 VDC	110 VAC	12/24 VDC	110 VAC	220 VAC	
Load current	5 to 100 mA	5 to 20 mA (Note 1)		100 mA or less			50 mA or less	5 to 50 mA	7 to 20 mA	50 mA or less	20 mA or less	5 to 50 mA	7 to 20 mA	7 to 10 mA
Light	LED (ON lighting)	LED (ON lighting)	Red/green LED (ON lighting)	LED (ON lighting)	Green LED (ON lighting)	Red/Green LED (ON lighting)	LED (ON lighting)		Without indicator light		LED (ON lighting)			
Leakage current	1 mA or less with 100 VAC 2 mA or less with 200 VAC	1 mA or less		10 μA or less			0 mA							

- With preventive maintenance output

Descriptions	Proximity 3-wire		Proximity 4-wire		Proximity 3-wire		Proximity 4-wire	
	T2YFH/V		T3YFH/V		T2YMH/V		T3YMH/V	
Applications	Programmable controller dedicated		Programmable controller, relay		Programmable controller dedicated		Programmable controller, relay	
Output method	NPN output							
Light	Red/Green LED (ON lighting)							
	Installation position adjustment		-		Yellow LED (ON lighting)			
Regular Output section	Power voltage		10 to 28 VDC		-		10 to 28 VDC	
	Load voltage		30 VDC or less		10 to 30 VDC		30 VDC or less	
	Load current		50 mA or less		5 to 20 mA		50 mA or less	
	Leakage current		10 μA or less		1.2 mA or less		10 μA or less	
Preventive maintenance Output section	30 VDC or less							
	Load current		50 mA or less		5 to 20 mA or less		50 mA or less	
	10 μA or less							

Note 1: Refer to Ending 1 for other switches.

Note 2: The above maximum load current of 20 mA applies at 25 °C. If the switch's working ambient temperature exceeds 25 °C, the load current will be lower than 20 mA. (5 to 10 mA when 60 °C)

Cylinder weight

(Unit: kg)

Descriptions/mounting style	Product weight when stroke length (S) = 0 mm			Additional weight			Switch weight	Switch rail + band weight	Additional weight per S = 10 mm
	Basic type	Axial foot type	Flange type	Basic type	Axial foot type	Flange type	Grommet		
Bore size (mm)	(00)	(LB)	(FA/FB)	(00)	(LB)	(FA)			
φ 20	0.17	0.32	0.23	0.03	0.18	0.09	0.018	0.005	0.01
φ 25	0.26	0.52	0.41	0.03	0.29	0.18	0.018	0.005	0.01
φ 32	0.30	0.56	0.45	0.05	0.31	0.20	0.018	0.009	0.02
φ 40	0.48	0.74	0.63	0.10	0.36	0.25	0.018	0.009	0.02

(weight of S1)

When S = 0 mm, product weight is 0.45 kg

Additional weight at S = 50 mm is additional weight at S = 10 mm $0.02 \times \frac{\text{Product stroke length (50)}}{10} = 0.10$ kg

Weight of two switches is 0.036 kg

Weight of switch rail and two bands is 0.018 kg

Weight of S1 is 0.45 kg + 0.1 kg + 0.036 kg + 0.018 kg = 0.604 kg

(weight of S2)

When S = 0 mm, product weight is 0.45 kg

Additional weight at S = 50 mm is additional weight at S = 10 mm $0.02 \times \frac{\text{Product stroke length (50)}}{10} = 0.10$ kg

Weight of two switches is 0.036 kg

Weight of switch rail and two bands is 0.018 kg

Weight of S2 is 0.45 kg + 0.10 kg + 0.036 kg + 0.018 kg = 0.604 kg

Product weight (S1 weight + S2 weight + additional weight) is

0.604 kg + 0.604 kg + 0.20 kg = 1.408 kg

(E.g.)

Product weight of

CMK2-B-FA-32-50-T0H-D-50-TOH-R

S₁

S₂

SCP*2
CMK2
CMA2
SCM
SCG
SCA2
SCS
CKV2
CA/OV2
SSD
CAT
MDC2
MVC
SMD2
MSD*
FC*
STK
ULK*
JSK/M2
JSG
JSC3
USSD
USC
JSB3
LMB
STG
STS/L
LCS
LCG
LCM
LCT
LCY
STR2
UCA2
HCM
HCA
SRL2
SRG
SRM
SRT
MRL2
MRG2
SM-25
CAC3
UCAC
RCC2
MFC
SHC
GLC
Ending

Medium bore size cylinder
Standard type

CMK2-B Series

How to order

Without switch

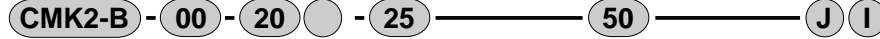

With switch



A Mounting style B Bore size

C Port thread type

D Stroke length

D Stroke length

E Switch model no.

E Switch model no.

F Switch quantity
Note 8

F Switch quantity

G Option
Note 2
Note 3
Note 4

Note on model no. selection

Note 1: Refer to page 160 for min. stroke length with switch.

Note 2: For bellows "J" type, stroke length should be longer than 25 mm. Consult with CKD when stroke length is shorter than 25 mm.

Note 3: Applicable tube O.D. of F; push-in joint (straight), FE; push-in joint (elbow) is $\phi 6$.

Note 4: Instantaneous maximum temperature is the temperature when spark and spatter etc. instantaneously contacts to bellows.

Note 5: Refer to Ending 89 for custom specifications of rod end form.

Note 6: Refer to page 84 for variation and combinations of options.

Note 7: With the back to back type, the port alignment is adjusted with spacers, so X and M dimensions have a tolerance of 0 to 1.5 mm.

Note 8: Up to three switches can be mounted. If more than four switches are required, switch mounting brackets for the extra switches must be prepared separately.

<Example of model number>

CMK2-B-00-20-25-T0H-D-50-T0H-R-JI

Model: Medium bore size cylinder double acting back to back type

- A Mounting style : Basic type
- B Bore size : $\phi 20$ mm
- C Port thread type : Rc thread
- D Stroke length (S1) : 25 mm
- E Switch model no. (S1) : Reed T0H switch
Lead wire 1 m
1st step stroke 25 mm indicated with S1
+2nd step stroke 50 mm indicated with S2
Total stroke length 75 mm S1 + S2
- F Switch quantity (S1) : Two
- D Stroke length (S2) : 50 mm
- E Switch model no. (S2) : Reed T0H switch and lead wire 1 m
- F Switch quantity (S2) : One on rod end
- G Option : Bellows, max. ambient temperature 100 °C or instantaneous max. temperature 200 °C
- H Accessory : Rod eye

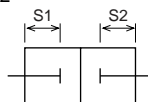

Symbol	Descriptions
A Mounting style	
00	Basic type
LB	Axial foot type (both sides)
FA	Rod side flange type

B Bore size (mm)	
20	$\phi 20$
25	$\phi 25$
32	$\phi 32$
40	$\phi 40$

C Port thread type	
Blank	Rc thread
NN	NPT thread (custom order)
GN	G thread (custom order)

D Stroke length (mm)		
Bore size	Stroke length Note 1	Custom stroke length
$\phi 20$	5 to 750	By 1 mm increment
$\phi 25$	5 to 750	
$\phi 32$	5 to 750	
$\phi 40$	5 to 750	

E Switch model no.				
Lead wire Straight type	Lead wire L type	Contact	Indicator	Lead wire
T0H*	T0V*	Reed	1 color	2-wire
T5H*	T5V*		Without indicator light	
T8H*	T8V*		1 color	
T1H*	T1V*	Proximity	1 color	2-wire
T2H*	T2V*			1 color (custom order)
T3H*	T3V*		2 color	
T3PH*	T3PV*			2 color (w/o light for preventive maintenance output)
T2YH*	T2YV*		2 color (Light available for preventive maintenance output (1 color))	
T3YH*	T3YV*			Off-delay type
T2YFH*	T2YFV*		4 wire	
T3YFH*	T3YFV*	3-wire		
T2YMH*	T2YMV*	4 wire		
T3YMH*	T3YMV*	2-wire		
T2JH*	T2JV*			

* Lead wire length	
Blank	1 m (standard)
3	3 m (option)
5	5 m (option)

F Switch quantity	
R	One on rod end
H	One on head end
D	Two
T	Three

G Option			
		Max. ambient	Max. instantaneous
J	Bellows	100 °C	200 °C
L	Bellows	250 °C	400 °C
F	Push-in joint (straight)		
FE	Push-in joint (elbow)		
M	Piston rod material (stainless steel)		
P6	Copper and PTFE free		

H Accessory	
I	Rod eye
Y	Rod clevis (pin and washer split pin attached)
B2	Clevis bracket (pin and snap ring attached)

How to order switch

- Switch body + mounting bracket

CMK2 - T0H - 20

Bore size (item ⑤ on previous page)

Switch model no. (item ④ on previous page)

- Only switch body

SW - T0H

Switch model no. (item ④ on previous page)

- Mounting bracket

CMK2 - T - 20

Bore size

(item ⑤ on previous page)
Bracket

How to order mounting bracket

Bore size (mm)	$\phi 20$	$\phi 25$	$\phi 32$	$\phi 40$
Mounting bracket				
Axial foot type (LB)	M1-LB-20	M1-LB-30	M1-LB-30	M1-LB-30
Flange (FA)	M1-FA-20	M1-FA-30	M1-FA-30	M1-FA-30

Note 1: Mounting nut/toothed washer are attached to each mounting bracket.

Note 2: Two sets of "M1-LB-*" in the above table are required for the axial direction foot (double-sided).

SCP*2
CMK2
CMA2
SCM
SCG
SCA2
SCS
CKV2
CA/OV2
SSD
CAT
MDC2
MVC
SMD2
MSD*
FC*
STK
ULK*
JSK/M2
JSG
JSC3
USSD
USC
JSB3
LMB
STG
STS/L
LCS
LCG
LCM
LCT
LCY
STR2
UCA2
HCM
HCA
SRL2
SRG
SRM
SRT
MRL2
MRG2
SM-25
CAC3
UCAC
RCC2
MFC
SHC
GLC
Ending

Medium bore size cylinder
Standard type

Internal structure and parts list

- SCP*2
- CMK2**
- CMA2
- SCM
- SCG
- SCA2
- SCS
- CKV2
- CA/OV2
- SSD
- CAT
- MDC2
- MVC
- SMD2
- MSD*
- FC*
- STK
- ULK*
- JSK/M2
- JSG
- JSC3
- USSD
- USC
- JSB3
- LMB
- STG
- STS/L
- LCS
- LCG
- LCM
- LCT
- LCY
- STR2
- UCA2
- HCM
- HCA
- SRL2
- SRG
- SRM
- SRT
- MRL2
- MRG2
- SM-25
- CAC3
- UCAC
- RCC2
- MFC
- SHC
- GLC
- Ending

● CMK2-B

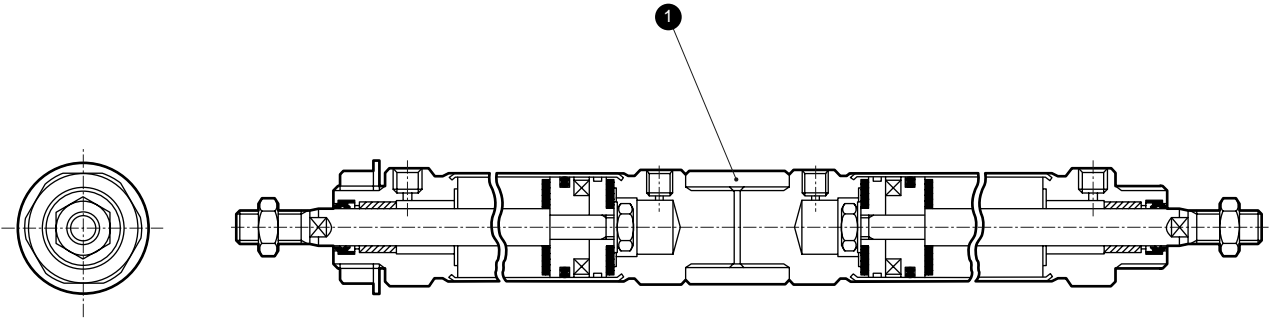

● Note: This caulking type cannot be disassembled.

No.	Parts name	Material	Remarks
1	Adaptor	Aluminum alloy	

Applications

Three positions are available when the same stroke is combined.

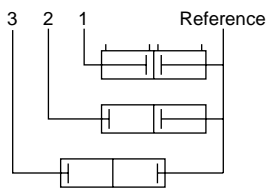

Four positions are available when different strokes are combined.

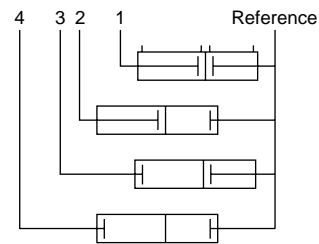

Dimensions

● Back to back type

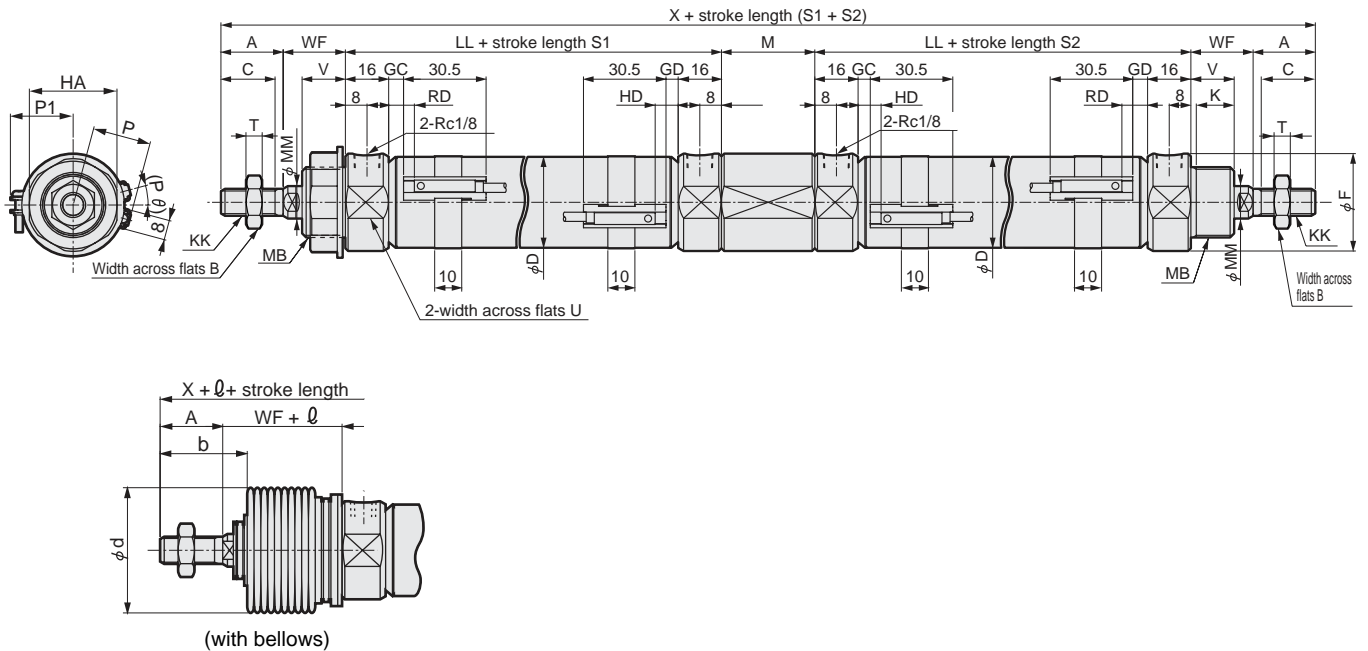

Note 1: Refer to page 188 for the HD, RD, and projecting dimensions of the T1* and T8* switches and 2-color indicator switch with preventive maintenance output.
 Note 2: For ℓ dimensions, round up decimal point or less.
 Note 3: Refer to page 190 for dimensions of accessories.

RD: Rod side max. sensitive position
 HD: Head side max. sensitive position

Symbol	Basic type (00) basic dimensions																
Bore size (mm)	A	B	C	D	F	HA	K	KK	LL	M	MB	MM	T	U	V	WF	X
φ20	20	13	18	21.4	28	26	12	M8 x 1.0	66	29 to 30.5	M18 x 1.5	10	5	24	14	24	249 to 250.5
φ25	23	17	20	26.4	32	35	14	M10 x 1.25	69	33 to 34.5	M26 x 1.5	12	6	30	16	23	263 to 264.5
φ32	23	17	20	33.6	36	35	14	M10 x 1.25	69	33 to 34.5	M26 x 1.5	12	6	34	16	23	263 to 264.5
φ40	25	19	22	41.6	45	35	14	M12 x 1.5	73	33 to 34.5	M26 x 1.5	14	7	43	16	23	275 to 276.5
Symbol	With switch							With bellows									
Bore size (mm)	GC	GD	RD	HD	P	P1	(Pθ)°	b	d	ℓ							
φ20	4.0	3.0	8.0	7.0	17.3	19.5	22	30	30	(stroke length/3) + 6							
φ25	5.5	4.5	9.5	8.5	19.8	22.0	18	32	46	(stroke length/3.25) + 7							
φ32	5.5	4.5	9.5	8.5	24.3	25.5	15	32	46	(stroke length/3.25) + 7							
φ40	7.0	6.5	11.5	10.5	28.3	29.5	12	34	46	(stroke length/3.25) + 7							

Note: With the back to back type, the port alignment is adjusted with spacers, so X and M dimensions have a tolerance of 0 to 1.5 mm.

Dimensions of each mounting type are same as standard type. Refer to pages 96 to 101.

SCP*2
CMK2
CMA2
SCM
SCG
SCA2
SCS
CKV2
CA/OV2
SSD
CAT
MDC2
MVC
SMD2
MSD*
FC*
STK
ULK*
JSK/M2
JSG
JSC3
USSD
USC
JSB3
LMB
STG
STS/L
LCS
LCG
LCM
LCT
LCY
STR2
UCA2
HCM
HCA
SRL2
SRG
SRM
SRT
MRL2
MRG2
SM-25
CAC3
UCAC
RCC2
MFC
SHC
GLC
Ending

Medium bore size cylinder
 Standard type

SCP*2
CMK2
 CMA2
 SCM
 SCG
 SCA2
 SCS
 CKV2
 CA/OV2
 SSD
 CAT
 MDC2
 MVC
 SMD2
 MSD*
 FC*
 STK
 ULK*
 JSK/M2
 JSG
 JSC3
 USSD
 USC
 JSB3
 LMB
 STG
 STS/L
 LCS
 LCG
 LCM
 LCT
 LCY
 STR2
 UCA2
 HCM
 HCA
 SRL2
 SRG
 SRM
 SRT
 MRL2
 MRG2
 SM-25
 CAC3
 UCAC
 RCC2
 MFC
 SHC
 GLC
 Ending

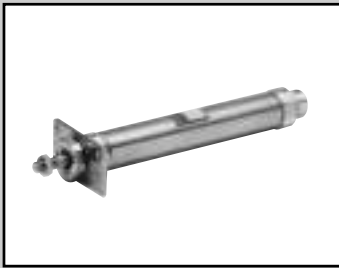

Medium bore size cylinder
 Double acting, non-rotating type

CMK2-M Series

● Bore size: ϕ 20, ϕ 25, ϕ 32, ϕ 40

JIS symbol ● Double acting non-rotating cylinder single rod type

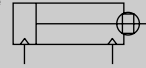

Specifications

Descriptions		CMK2-M			
Bore size mm	mm	ϕ 20	ϕ 25	ϕ 32	ϕ 40
Actuation		Double acting non-rotating type			
Working fluid		Compressed air			
Max. working pressure	MPa	1.0			
Min. working pressure	MPa	0.1			
Withstanding pressure	MPa	1.6			
Ambient temperature	°C	-10 to 60 (no freezing)			
Port size		Rc1/8			
Stroke tolerance		$^{+2.0}_0$ (up to 200), $^{+2.4}_0$ (over 200)			
Working piston speed	mm/s	50 to 500			
Cushion		Rubber cushion			
Lubrication		Not required (when lubricating, use turbine oil Class 1 ISO VG32.)			
Revolvable angle tolerance (note)	degree	± 1.5			± 1.0
Allowable energy absorption	J	0.166	0.308	0.424	0.639

Note: Value when stroke length is 0 mm (excluding deflection of piston rod).

Stroke length

Bore size (mm)	Standard stroke length (mm)	Max. stroke length (mm)	Min. stroke length (mm)
ϕ 20	25, 50, 75, 100, 150, 200, 250, 300	750	5
ϕ 25			
ϕ 32			
ϕ 40			

Note 1: Custom stroke length is available per 1 mm increment.

Note 2: For single foot type (LS type), maximum stroke length is 50 mm.

Note 3: For bellows "J" type, stroke length should be longer than 25 mm. Consult with CKD when stroke length is shorter than 25 mm.

Min. stroke length of type with switch

(Unit: mm)

Switch quantity	1					2				3			
	Proximity		Reed			Proximity		Reed		Proximity		Reed	
	T2, T3	T1, T*Y*	T0, T5	T8	T2, T3	T1, T*Y*	T0, T5	T8	T2, T3	T1, T*Y*	T0, T5	T8	
ϕ 20	10					25	35	25	35	50	55	50	55
ϕ 25	10					25	35	25	35	50	55	50	55
ϕ 32	10					25	35	25	35	50	55	50	55
ϕ 40	10					25	35	25	35	50	55	50	55

Note 1: Up to three switches can be mounted.

- SCP*2
- CMK2**
- CMA2
- SCM
- SCG
- SCA2
- SCS
- CKV2
- CA/OV2
- SSD
- CAT
- MDC2
- MVC
- SMD2
- MSD*
- FC*
- STK
- ULK*
- JSK/M2
- JSG
- JSC3
- USSD
- USC
- JSB3
- LMB
- STG
- STS/L
- LCS
- LCG
- LCM
- LCT
- LCY
- STR2
- UCA2
- HCM
- HCA
- SRL2
- SRG
- SRM
- SRT
- MRL2
- MRG2
- SM-25
- CAC3
- UCAC
- RCC2
- MFC
- SHC
- GLC

Switch specifications

● 1 color/2 color indicator

* The T0/T5 switch can be used with 220 VAC.
Contact CKD for working conditions.

Descriptions	Proximity 2-wire			Proximity 3-wire			Reed 2-wire						
	T1H/T1V	T2H/T2V/ T2JH/T2JV	T2YH/T2YV	T3H/T3V	T3PH/T3PV (Custom order)	T3YH/T3YV	TOH/TOV		T5H/T5V		T8H/T8V		
Applications	Programmable controller Relay, small solenoid valve		Programmable controller dedicated	Programmable controller, relay			Programmable controller, relay		Programmable controller, relay, IC circuit (w/o light), serial connection		Programmable controller, relay		
Output method	-			NPN output	PNP output	NPN output	-						
Power voltage	-			10 to 28 VDC			-						
Load voltage	85 to 265 VAC		10 to 30 VDC	30 VDC or less			12/24 VDC	110 VAC	5/12/24 VDC	110 VAC	12/24 VDC	110 VAC	220 VAC
Load current	5 to 100 mA		5 to 20 mA (Note 1)	100 mA or less		50 mA or less	5 to 50 mA	7 to 20 mA	50 mA or less	20 mA or less	5 to 50 mA	7 to 20 mA	7 to 10 mA
Light	LED (ON lighting)		LED (ON lighting)	Red/green LED (ON lighting)	LED (ON lighting)	Green LED (ON lighting)	Red/Green LED (ON lighting)	LED (ON lighting)		Without indicator light		LED (ON lighting)	
Leakage current	1 mA or less with 100 VAC 2 mA or less with 200 VAC		1 mA or less	10 μA or less			0 mA						

● With preventive maintenance output

Descriptions	Proximity 3-wire		Proximity 4-wire		Proximity 3-wire		Proximity 4-wire	
	T2YFH/V		T3YFH/V		T2YMH/V		T3YMH/V	
Applications	Programmable controller dedicated		Programmable controller, relay		Programmable controller dedicated		Programmable controller, relay	
Output method	NPN output							
Light	Red/Green LED (ON lighting)							
	Installation position adjustment		-		Yellow LED (ON lighting)			
Regular Output section	Power voltage		10 to 28 VDC		-		10 to 28 VDC	
	Load voltage		30 VDC or less		10 to 30 VDC		30 VDC or less	
	Load current		50 mA or less		5 to 20 mA		50 mA or less	
	Leakage current		10 μA or less		1.2 mA or less		10 μA or less	
Preventive maintenance Output section	30 VDC or less							
	Load voltage		50 mA or less		5 to 20 mA or less		50 mA or less	
	Load current		10 μA or less					

Note 1: Refer to Ending 1 for other switches.

Note 2: The above maximum load current of 20 mA applies at 25 °C. If the switch's working ambient temperature exceeds 25 °C, the load current will be lower than 20 mA.
(5 to 10 mA when 60 °C)

Cylinder weight

(Unit: kg)

Descriptions/mounting style	This is product mass when stroke length (S) = 00 mm								Switch weight	Switch rail + band weight	Additional weight per S = 10 mm
	Basic type (00)	Axial foot type (LB)	Axial foot type (LS)	Flange type (FA/FB)	Eye bracket type (CA)	Clevis type (CC)	Clevis bracket type (CB)	Trunnion type (TA/TB)	Grommet		
φ20	0.17	0.32	0.25	0.23	0.32	0.18	0.32	0.22	0.018	0.005	0.01
φ25	0.26	0.52	0.39	0.41	0.50	0.26	0.50	0.36	0.018	0.005	0.01
φ32	0.30	0.56	0.43	0.45	0.54	0.30	0.54	0.40	0.018	0.009	0.02
φ40	0.48	0.74	0.61	0.63	0.72	0.50	0.72	0.64	0.018	0.009	0.02

(E.g.) Product weight of
CMK2-M-FA-32-50-T0H-D

When S = 00 mm, product weight is 0.45 kg

Additional weight at S = 50 mm is additional weight at S = 10 mm $0.02 \times \frac{\text{Product stroke length (50)}}{10} = 0.10$ kg

Weight of two switches is 0.036 kg

Weight of switch rail and two bands is 0.018 kg

Product weight is 0.45 kg + 0.1 kg + 0.036 kg + 0.018 kg = 0.604 kg

Medium bore size cylinder
Standard type

How to order

Without switch



With switch

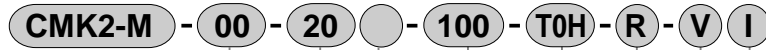

A Mounting style
Note 1

B Bore size

C Port thread type

D Stroke length

E Switch model no.

Note on model no. selection

Note 1: The maximum stroke of the single-end foot type (LS type) is 50 mm.

Note 2: Refer to page 166 for min. stroke length with switch.

Note 3: Applicable tube O.D. of F; push-in joint (straight), FE; push-in joint (elbow) is $\phi 6$.

Note 4: For bellows "J" type, stroke length should be more than 25 mm. Consult with CKD when stroke length is shorter than 25 mm.

Note 5: Instantaneous maximum temperature is the temperature when spark and spatter etc. instantaneously contacts to bellows.

Note 6: "I" "Y" can not be selected at the same time.

Note 7: Refer to Ending 89 for the custom order specifications of rod end form.

Note 8: Refer to page 84 for variation and combinations of options.

Note 9: Up to three switches can be mounted. If more than four switches are required, switch mounting brackets for the extra switches must be prepared separately.

<Example of model number>

CMK2-M-00-20-100-T0H-R-VI

Model: Medium bore size cylinder, double acting, non-rotating type

- A** Mounting style : Basic type
- B** Bore size : $\phi 20$ mm
- C** Port thread type : Rc thread
- D** Stroke length : 100 mm
- E** Switch model no. : reed T0H switch, lead wire 1 m
- F** Switch quantity : One on rod end
- G** Option : Boss cut off
- H** Accessory : Rod eye

G Option
Note 3, Note 4, Note 5

F Switch quantity
Note 9

H Accessory
Note 6

Symbol	Descriptions
A Mounting style	
00	Basic type
LB	Axial foot type (both sides)
LS	Axial foot type (single)
FA	Rod side flange type
FB	Head side flange type
CA	Eye bracket type
CC	Fixed eye
CC1	Eye and bush press fitted type
CB	Clevis bracket type (pin and washer split pin attached)
TA	Rod side trunnion type
TB	Head side trunnion type

B Bore size (mm)	
20	$\phi 20$
25	$\phi 25$
32	$\phi 32$
40	$\phi 40$

C Port thread type	
Blank	Rc thread
NN	NPT thread (custom order)
GN	G thread (custom order)

D Stroke length (mm)		
Bore size	Stroke length Note 2	Custom stroke length
$\phi 20$	5 to 750	By 1 mm increment
$\phi 25$	5 to 750	
$\phi 32$	5 to 750	
$\phi 40$	5 to 750	

E Switch model no.					
Lead wire Straight type	Lead wire L type	Contact	Indicator	Lead wire	
T0H*	T0V*	Reed	1 color	2-wire	
T5H*	T5V*		Without indicator light		
T8H*	T8V*		1 color		
T1H*	T1V*	Proximity	1 color	2-wire	
T2H*	T2V*				
T3H*	T3V*				3-wire
T3PH*	T3PV*		1 color (custom order)		
T2YH*	T2YV*		2 color	2-wire	
T3YH*	T3YV*			3-wire	
T2YFH*	T2YFV*		2 color (w/o light for preventive maintenance output)	2 color	3-wire
T3YFH*	T3YFV*				4 wire
T2YMH*	T2YMV*				2 color (Light available for preventive maintenance output (1 color))
T3YMH*	T3YMV*	4 wire			
T2JH*	T2JV*	Off-delay type	2-wire		

* Lead wire length	
Blank	1 m (standard)
3	3 m (option)
5	5 m (option)

F Switch quantity	
R	One on rod end
H	One on head end
D	Two
T	Three

G Option			
		Max. ambient	Max. instantaneous
J	Bellows	100 °C	200 °C
L	Bellows	250 °C	400 °C
F	Push-in joint (straight)		
FE	Push-in joint (elbow)		
V	Boss cut off		
M	Piston rod material (stainless steel)		

H Accessory	
I	Rod eye
Y	Rod clevis (pin and washer split pin attached)
B2	Clevis bracket (pin and snap ring attached)

How to order switch

- Switch body + mounting bracket

CMK2 - **T0H** - **20**

Bore size (item ⑤ on previous page)

Switch model no. (item ④ on previous page)

- Only switch body

SW - **T0H**

Switch model no. (item ④ on previous page)

- Mounting bracket

CMK2 - **T** - **20**

Bore size (item ⑤ on previous page)

Bracket

How to order mounting bracket

Bore size (mm)	$\phi 20$	$\phi 25$	$\phi 32$	$\phi 40$
Axial foot type (LB/LS)	M1-LB-20	M1-LB-30	M1-LB-30	M1-LB-30
Flange (FA/FB)	M1-FA-20	M1-FA-30	M1-FA-30	M1-FA-30
Trunnion (TA)	M1-TA-20	M1-TA-30	M1-TA-30	M1-TA-40
Eye bracket type (CA)	M1-CA-20	M1-CA-30	M1-CA-30	M1-CA-30
Clevis bracket type (CB)	M1-CB-20	M1-CB-30	M1-CB-30	M1-CB-30

Note 1: Mounting nut/toothed washer are attached to each mounting bracket.

Note 2: Two sets of "M1-LB-*" in the above table are required for the axial direction foot (double-sided).

SCP*2
CMK2
CMA2
SCM
SCG
SCA2
SCS
CKV2
CA/OV2
SSD
CAT
MDC2
MVC
SMD2
MSD*
FC*
STK
ULK*
JSK/M2
JSG
JSC3
USSD
USC
JSB3
LMB
STG
STS/L
LCS
LCG
LCM
LCT
LCY
STR2
UCA2
HCM
HCA
SRL2
SRG
SRM
SRT
MRL2
MRG2
SM-25
CAC3
UCAC
RCC2
MFC
SHC
GLC
Ending

Medium bore size cylinder
Standard type

Internal structure and parts list

- SCP*2
- CMK2**
- CMA2
- SCM
- SCG
- SCA2
- SCS
- CKV2
- CA/OV2
- SSD
- CAT
- MDC2
- MVC
- SMD2
- MSD*
- FC*
- STK
- ULK*
- JSK/M2
- JSG
- JSC3
- USSD
- USC
- JSB3
- LMB
- STG
- STS/L
- LCS
- LCG
- LCM
- LCT
- LCY
- STR2
- UCA2
- HCM
- HCA
- SRL2
- SRG
- SRM
- SRT
- MRL2
- MRG2
- SM-25
- CAC3
- UCAC
- RCC2
- MFC
- SHC
- GLC
- Ending

● CMK2-M

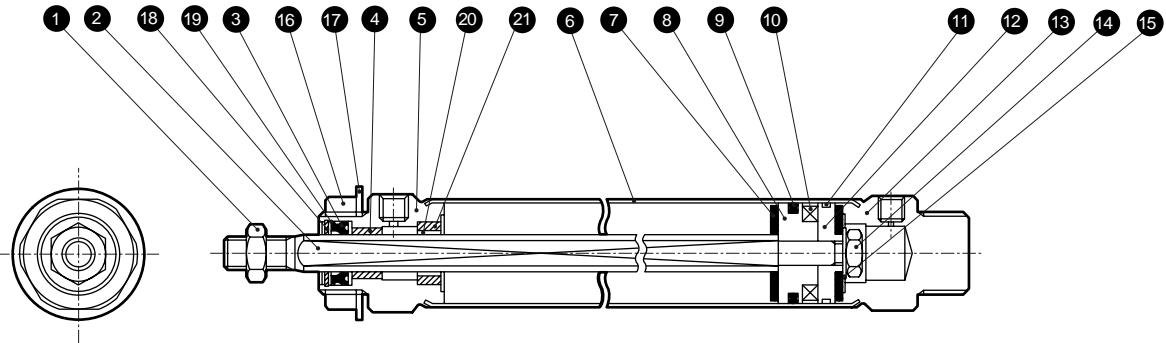

● Note: This caulking type cannot be disassembled.

No.	Parts name	Material	Remarks	No.	Parts name	Material	Remarks
1	Rod nut	Steel	Zinc chromate	14	Hexagon nut	Steel	Zinc chromate
2	Piston rod	Stainless steel		15	Spacer	Steel	Zinc chromate
3	Rod packing seal	Nitrile rubber		16	Nut	Steel	Zinc chromate
4	Bush	ϕ 20: Dry bearing ϕ 25, ϕ 32, ϕ 40: Copper		17	The toothed washer	Steel	Zinc chromate
5	Rod cover	Aluminum alloy		18	Round R type snap ring	Steel	Phosphoric acid zinc
6	Cylinder tube	Stainless steel		19	Packing gland	Steel	Zinc chromate
7	Cushion rubber	Urethane rubber		20	Non-rotating bush	Copper oil impregnated alloy	
8	Piston A	Aluminum alloy		21	Taper pin	Stainless steel	
9	Piston packing seal	Nitrile rubber					
10	Magnet	Plastic					
11	Wear ring	Polyacetal					
12	Piston B	Aluminum alloy					
13	Head cover	Aluminum alloy					

Mounting bracket material

Mounting style	Material
LB/LS	Steel
FA/FB	Steel
TA/TB	Steel
CA	Steel
CB	Steel

● Note: Mounting bracket is attached to the product when shipped.

Dimensions

- Basic type (00)
- T type with switch

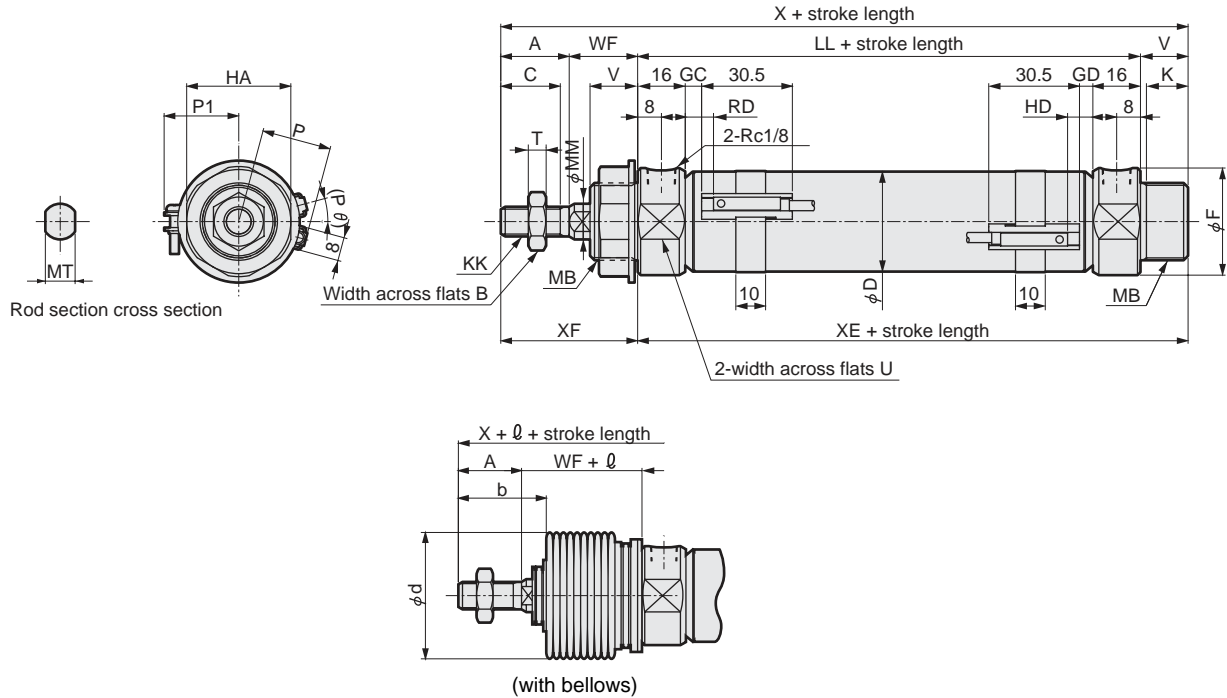

Note 1: Refer to page 188 for the HD, RD, and projecting dimensions of the T1* and T8* switches and 2-color indicator switch with preventive maintenance output.

RD: Rod side max. sensitive position
HD: Head side max. sensitive position

Note 2: For l dimensions, round up decimal point or less.
Note 3: Refer to page 190 for dimensions of accessories.

Symbol	A	B	C	D	F	HA	K	KK	LL	MB	MM	MT	T	U	V	WF	X	XE	XF
Bore size (mm)																			
$\phi 20$	20	13	18	21.4	28	26	12	M8 x 1.0	66	M18 x 1.5	10	8	5	24	14	24	124	80	44
$\phi 25$	23	17	20	26.4	32	35	14	M10 x 1.25	69	M26 x 1.5	12	10	6	30	16	23	131	85	46
$\phi 32$	23	17	20	33.6	36	35	14	M10 x 1.25	69	M26 x 1.5	12	10	6	34	16	23	131	85	46
$\phi 40$	25	19	22	41.6	45	35	14	M12 x 1.5	73	M26 x 1.5	14	12	7	43	16	23	137	89	48
Symbol	With switch							With bellows											
Bore size (mm)	GC	GD	RD	HD	P	P1	(P θ)°	b	d	l									
$\phi 20$	4.0	3.0	8.0	7.0	17.3	19.5	22	30	30	(stroke length/3) + 6									
$\phi 25$	5.5	4.5	9.5	8.5	19.8	22.0	18	32	46	(stroke length/3.25) + 7									
$\phi 32$	5.5	4.5	9.5	8.5	24.3	25.5	15	32	46	(stroke length/3.25) + 7									
$\phi 40$	7.0	6.5	11.5	10.5	28.3	29.5	12	34	46	(stroke length/3.25) + 7									

Dimensions of each mounting type are same as standard type. Refer to pages 96 to 101.

- SCP*2
- CMK2
- CMA2
- SCM
- SCG
- SCA2
- SCS
- CKV2
- CA/OV2
- SSD
- CAT
- MDC2
- MVC
- SMD2
- MSD*
- FC*
- STK
- ULK*
- JSK/M2
- JSG
- JSC3
- USSD
- USC
- JSB3
- LMB
- STG
- STS/L
- LCS
- LCG
- LCM
- LCT
- LCY
- STR2
- UCA2
- HCM
- HCA
- SRL2
- SRG
- SRM
- SRT
- MRL2
- MRG2
- SM-25
- CAC3
- UCAC
- RCC2
- MFC
- SHC
- GLC
- Ending

Medium bore size cylinder
Standard type

Medium bore size cylinder, double acting, flow control valve integrated type

CMK2-Z Series

● Bore size: ϕ 20, ϕ 25, ϕ 32, ϕ 40

RoHS



Specifications

Descriptions		CMK2-Z			
Bore size	mm	ϕ 20	ϕ 25	ϕ 32	ϕ 40
Actuation		Double acting integrated flow control valve type			
Working fluid		Compressed air			
Max. working pressure	MPa	1.0			
Min. working pressure	MPa	0.1			
Withstanding pressure	MPa	1.6			
Ambient temperature	°C	-10 to 60 (no freezing)			
Port size		Rc1/8			
Stroke tolerance	mm	$^{+2.0}_0$ (up to 200), $^{+2.4}_0$ (over 200)			
Working piston speed	mm/s	50 to 300			
Cushion		Rubber cushion			
Lubrication		Not required (when lubricating, use turbine oil Class 1 ISO VG32.)			
Allowable energy absorption	J	0.166	0.308	0.424	0.639

Stroke length

Bore size (mm)	Standard stroke length (mm)	Max. stroke length (mm)	Min. stroke length (mm)
ϕ 20	25, 50, 75, 100, 150, 200, 250, 300	750	5
ϕ 25			
ϕ 32			
ϕ 40			

Note 1: Custom stroke length is available per 1 mm increment.

Note 2: For single foot type (LS type), maximum stroke length is 50 mm.

Note 3: For bellows "J" type, stroke length should be longer than 25 mm.

Consult with CKD when stroke length is shorter than 25 mm.

Min. stroke length of type with switch

(Unit: mm)

Switch quantity	1				2				3			
	Proximity		Reed		Proximity		Reed		Proximity		Reed	
	T2, T3	T1, T*Y*	T0, T5	T8	T2, T3	T1, T*Y*	T0, T5	T8	T2, T3	T1, T*Y*	T0, T5	T8
ϕ 20	10				25	35	25	35	50	55	50	55
ϕ 25	10				25	35	25	35	50	55	50	55
ϕ 32	10				25	35	25	35	50	55	50	55
ϕ 40	10				25	35	25	35	50	55	50	55

Note 1: Up to three switches can be mounted.

- SCP*2
- CMK2**
- CMA2
- SCM
- SCG
- SCA2
- SCS
- CKV2
- CA/OV2
- SSD
- CAT
- MDC2
- MVC
- SMD2
- MSD*
- FC*
- STK
- ULK*
- JSK/M2
- JSG
- JSC3
- USSD
- USC
- JSB3
- LMB
- STG
- STS/L
- LCS
- LCG
- LCM
- LCT
- LCY
- STR2
- UCA2
- HCM
- HCA
- SRL2
- SRG
- SRM
- SRT
- MRL2
- MRG2
- SM-25
- CAC3
- UCAC
- RCC2
- MFC
- SHC
- GLC

Switch specifications

● 1 color/2 color indicator

* The T0/T5 switch can be used with 220 VAC. Contact CKD for working conditions.

Descriptions	Proximity 2-wire			Proximity 3-wire			Reed 2-wire						
	T1H/T1V	T2H/T2V/ T2JH/T2JV	T2YH/T2YV	T3H/T3V	T3PH/T3PV (Custom order)	T3YH/T3YV	TOH/TOV		T5H/T5V		T8H/T8V		
Applications	Programmable controller Relay, small solenoid valve		Programmable controller dedicated	Programmable controller, relay			Programmable controller, relay		Programmable controller, relay, IC circuit (w/o light), serial connection		Programmable controller, relay		
Output method	-			NPN output	PNP output	NPN output	-						
Power voltage	-			10 to 28 VDC			-						
Load voltage	85 to 265 VAC		10 to 30 VDC	30 VDC or less			12/24 VDC	110 VAC	5/12/24 VDC	110 VAC	12/24 VDC	110 VAC	220 VAC
Load current	5 to 100 mA		5 to 20 mA (Note 1)	100 mA or less		50 mA or less	5 to 50 mA	7 to 20 mA	50 mA or less	20 mA or less	5 to 50 mA	7 to 20 mA	7 to 10 mA
Light	LED (ON lighting)		LED (ON lighting)	Red/green LED (ON lighting)	LED (ON lighting)	Green LED (ON lighting)	Red/Green LED (ON lighting)	LED (ON lighting)		Without indicator light		LED (ON lighting)	
Leakage current	1 mA or less with 100 VAC 2 mA or less with 200 VAC		1 mA or less	10 μA or less			0 mA						

● With preventive maintenance output

Descriptions	Proximity 3-wire		Proximity 4-wire		Proximity 3-wire		Proximity 4-wire	
	T2YFH/V		T3YFH/V		T2YMH/V		T3YMH/V	
Applications	Programmable controller dedicated		Programmable controller, relay		Programmable controller dedicated		Programmable controller, relay	
Output method	NPN output							
Light	Red/Green LED (ON lighting)							
	Installation position adjustment		-		Yellow LED (ON lighting)			
Regular Output section	Power voltage		10 to 28 VDC		-		10 to 28 VDC	
	Load voltage		30 VDC or less		10 to 30 VDC		30 VDC or less	
	Load current		50 mA or less		5 to 20 mA		50 mA or less	
	Leakage current		10 μA or less		1.2 mA or less		10 μA or less	
Preventive maintenance Output section	30 VDC or less							
	Load current		50 mA or less		5 to 20 mA or less		50 mA or less	
	10 μA or less							

Note 1: Refer to Ending 1 for other switches.

Note 2: The above maximum load current of 20 mA applies at 25 °C. If the switch's working ambient temperature exceeds 25 °C, the load current will be lower than 20 mA. (5 to 10 mA when 60 °C)

Cylinder weight

(Unit: kg)

Descriptions/mounting style	Product weight when stroke length (S) = 0 mm								Switch weight	Switch rail + band weight	Additional weight per S = 10 mm
	Basic type (00)	Axial foot type (LB)	Axial foot type (LS)	Flange type (FA/FB)	Eye bracket type (CA)	Clevis type (CC)	Clevis bracket type (CB)	Trunnion type (TA/TB)	Grommet		
φ20	0.18	0.33	0.26	0.24	0.33	0.19	0.33	0.23	0.018	0.005	0.01
φ25	0.28	0.54	0.41	0.43	0.52	0.28	0.52	0.38	0.018	0.005	0.01
φ32	0.32	0.58	0.45	0.47	0.56	0.32	0.56	0.42	0.018	0.009	0.02
φ40	0.51	0.77	0.64	0.66	0.75	0.53	0.75	0.67	0.018	0.009	0.02

(E.g.) Product weight of CMK2-Z-FA-32-50-TOH-D

When S = 0 mm, product weight is 0.47 kg

Additional weight at S = 50 mm is additional weight at S = 10 mm $0.02 \times \frac{\text{Product stroke length (50)}}{10} = 0.10$ kg

Weight of two switches is 0.036 kg

Weight of switch rail and two bands is 0.018 kg

Product weights is 0.47 kg + 0.1 kg + 0.036 kg + 0.018 kg = 0.624 kg

Medium bore size cylinder
Standard type

How to order

Without switch

CMK2-Z - 00 - 20 - 100 - V Y

With switch

CMK2-Z - 00 - 20 - 100 - T0H - R - V Y

A Mounting style
Note 1

B Bore size

C Port thread type

D Stroke length

E Switch model no.

F Switch quantity
Note 9

G Option
Note 3, Note 4, Note 5

H Accessory
Note 6

Note on model no. selection

Note 1: The maximum stroke of the single-end foot type (LS type) is 50 mm.

Note 2: Refer to page 172 for min. stroke length with switch.

Note 3: Applicable tube O.D. of F; push-in joint (straight), FE; push-in joint (elbow) is $\phi 6$.

Note 4: For bellows "J" type, stroke length should be more than 25 mm. Consult with CKD when stroke length is shorter than 25 mm.

Note 5: Instantaneous maximum temperature is the temperature when spark and spatter etc. instantaneously contacts to bellows.

Note 6: "I" "Y" can not be selected at the same time.

Note 7: Refer to Ending 89 for the custom order specifications of rod end form.

Note 8: Refer to page 84 for variation and combinations of options.

Note 9: Up to three switches can be mounted. If more than four switches are required, switch mounting brackets for the extra switches must be prepared separately.

<Example of model number>

CMK2-Z-00-20-100-T0H-R-VY

Model: Medium bore size cylinder, double acting, speed controller integrated type

- A** Mounting style : Basic type
- B** Bore size : $\phi 20$ mm
- C** Port thread type : Rc thread
- D** Stroke length : 100 mm
- E** Switch model no. : Reed T0H switch and lead wire 1 m
- F** Switch quantity : One on rod end
- G** Option : Boss cut off
- H** Accessory : Rod clevis

Symbol	Descriptions
A Mounting style	
00	Basic type
LB	Axial foot type (both sides)
LS	Axial foot type (single)
FA	Rod side flange type
FB	Head side flange type
CA	Eye bracket type
CC	Fixed eye
CC1	Eye and bush press fitted type
CB	Clevis bracket type (pin and washer split pin attached)
TA	Rod side trunnion type
TB	Head side trunnion type

B Bore size (mm)	
20	$\phi 20$
25	$\phi 25$
32	$\phi 32$
40	$\phi 40$

C Port thread type	
Blank	Rc thread
NN	NPT thread (custom order)
GN	G thread (custom order)

D Stroke length (mm)		
Bore size	Stroke length Note 2	Bore size
$\phi 20$	5 to 750	By 1 mm increment
$\phi 25$	5 to 750	
$\phi 32$	5 to 750	
$\phi 40$	5 to 750	

E Switch model no.				
Lead wire Straight type	Lead wire L type	Contact	Indicator	Lead wire
T0H*	T0V*	Reed	1 color	2-wire
T5H*	T5V*		Without indicator light	
T8H*	T8V*		1 color	
T1H*	T1V*	Proximity	1 color	2-wire
T2H*	T2V*			
T3H*	T3V*			
T3PH*	T3PV*		1 color (custom order)	3-wire
T2YH*	T2YV*		2 color	
T3YH*	T3YV*			(w/o light for preventive maintenance output)
T2YFH*	T2YFV*		3-wire	
T3YFH*	T3YFV*		4 wire	
T2YMH*	T2YMV*		(Light available for preventive maintenance output (1 color))	2 color
T3YMH*	T3YMV*	4 wire		
T2JH*	T2JV*	Off-delay type	2-wire	

* Lead wire length	
Blank	1 m (standard)
3	3 m (option)
5	5 m (option)

F Switch quantity	
R	One on rod end
H	One on head end
D	Two
T	Three

G Option			
		Max. ambient	Max. instantaneous
J	Bellows	100°C	200°C
L	Bellows	250°C	400°C
F	Push-in joint (straight)		
FE	Push-in joint (elbow)		
M	Piston rod material (stainless steel)		
V	Boss cut off		
P6	Copper and PTFE free (custom order)		

H Accessory	
I	Rod eye
Y	Rod clevis (pin and washer split pin attached)
B2	Clevis bracket (pin and snap ring attached)

How to order switch

- Switch body + mounting bracket

CMK2 - **T0H** - **20**

Bore size (item ③ on previous page)

Switch model no. (item ① on previous page)

- Only switch body

SW - **T0H**

Switch model no. (item ① on previous page)

- Mounting bracket

CMK2 - **T** - **20**

Bore size (item ③ on previous page)

Bracket

How to order mounting bracket

Bore size (mm)	φ20	φ25	φ32	φ40
Mounting bracket				
Axial foot type (LB/LS)	M1-LB-20	M1-LB-30	M1-LB-30	M1-LB-30
Flange (FA/FB)	M1-FA-20	M1-FA-30	M1-FA-30	M1-FA-30
Trunnion (TA/TB)	M1-TA-20	M1-TA-30	M1-TA-30	M1-TA-40
Eye bracket type (CA)	M1-CA-20	M1-CA-30	M1-CA-30	M1-CA-30
Clevis bracket type (CB)	M1-CB-20	M1-CB-30	M1-CB-30	M1-CB-30

Note 1: Mounting nut/toothed washer are attached to each mounting bracket.

Note 2: Two sets of "M1-LB-*" in the above table are required for the axial direction foot (double-sided).

SCP*2
CMK2
CMA2
SCM
SCG
SCA2
SCS
CKV2
CA/OV2
SSD
CAT
MDC2
MVC
SMD2
MSD*
FC*
STK
ULK*
JSK/M2
JSG
JSC3
USSD
USC
JSB3
LMB
STG
STS/L
LCS
LCG
LCM
LCT
LCY
STR2
UCA2
HCM
HCA
SRL2
SRG
SRM
SRT
MRL2
MRG2
SM-25
CAC3
UCAC
RCC2
MFC
SHC
GLC
Ending

Medium bore size cylinder
Standard type

Internal structure and parts list

- SCP*2
- CMK2**
- CMA2
- SCM
- SCG
- SCA2
- SCS
- CKV2
- CA/OV2
- SSD
- CAT
- MDC2
- MVC
- SMD2
- MSD*
- FC*
- STK
- ULK*
- JSK/M2
- JSG
- JSC3
- USSD
- USC
- JSB3
- LMB
- STG
- STS/L
- LCS
- LCG
- LCM
- LCT
- LCY
- STR2
- UCA2
- HCM
- HCA
- SRL2
- SRG
- SRM
- SRT
- MRL2
- MRG2
- SM-25
- CAC3
- UCAC
- RCC2
- MFC
- SHC
- GLC
- Ending

● CMK2-Z

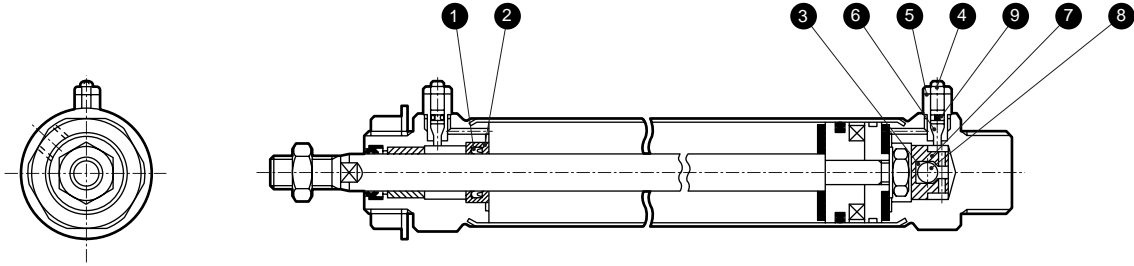

● Note: This caulking type cannot be disassembled.

No.	Parts name	Material	Remarks	No.	Parts name	Material	Remarks
1	Check packing seal	Nitrile rubber		5	Needle holder	Steel	Zinc chromate
2	Packing seal adaptor	Carbon steel	Chromate	6	Needle	Steel	Zinc chromate
3	Check ball holder	Steel	Zinc chromate	7	Check ball holder	Carbon steel	Blackening
4	Hexagon nut	Steel	Zinc chromate	8	Urethane ball	Urethane rubber	
				9	Needle gasket	Nitrile rubber	

Dimensions

● Integrated flow control valve type

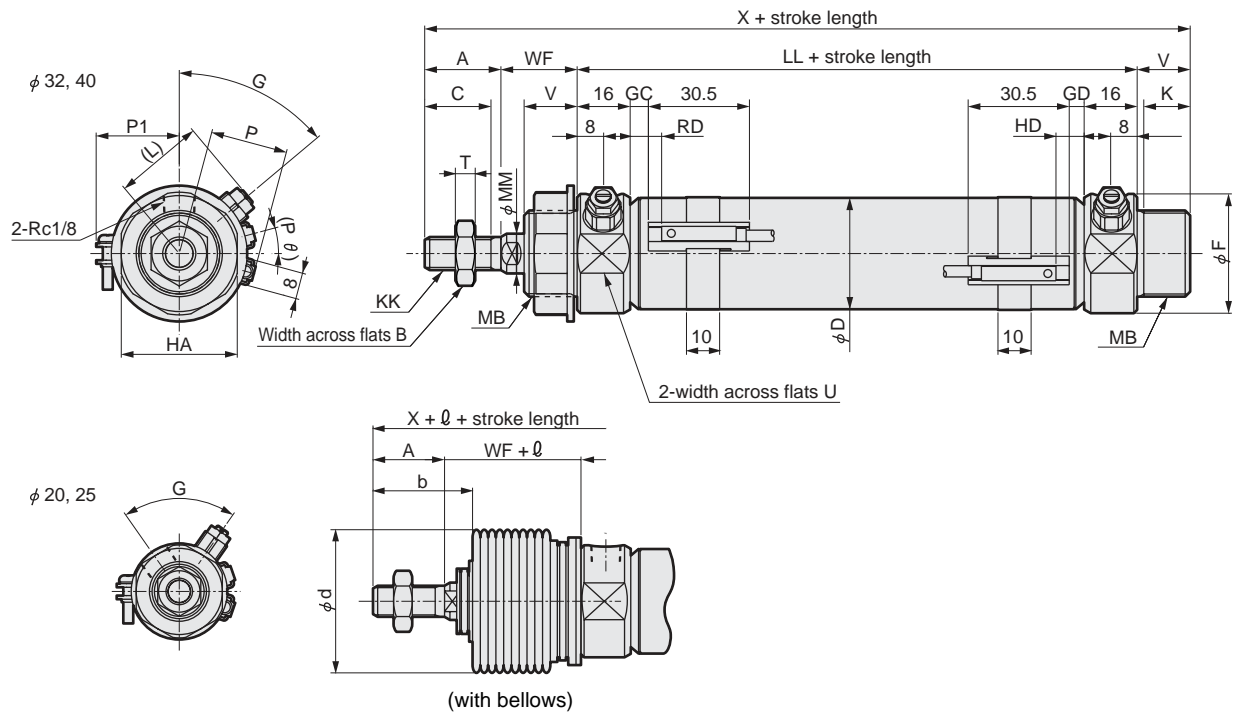

Note 1: Refer to page 188 for the HD, RD, and projecting dimensions of the T1* and T8* switches and 2-color indicator switch with preventive maintenance output.

RD: Rod side max. sensitive position
HD: Head side max. sensitive position

Note 2: For ℓ dimensions, round up decimal point or less.

Note 3: Refer to page 190 for dimensions of accessories.

Symbol	Basic type (00) basic dimensions																	
Bore size (mm)	A	B	C	D	F	G	HA	K	KK	L	LL	MB	MM	T	U	V	WF	X
φ 20	20	13	18	21.4	28	70°	26	12	M8 x 1.0	23	66	M18 x 1.5	10	5	24	14	24	124
φ 25	23	17	20	26.4	32	60°	35	14	M10 x 1.25	26	69	M26 x 1.5	12	6	30	16	23	131
φ 32	23	17	20	33.6	36	50°	35	14	M10 x 1.25	27	69	M26 x 1.5	12	6	34	16	23	131
φ 40	25	19	22	41.6	45	50°	35	14	M12 x 1.5	31	73	M26 x 1.5	14	7	43	16	23	137
Symbol	With switch							With bellows										
Bore size (mm)	GC	GD	RD	HD	P	P1	(Pθ)°	b	d	ℓ								
φ 20	4.0	3.0	8.0	7.0	17.3	19.5	22	30	30	(stroke length/3) + 6								
φ 25	5.5	4.5	9.5	8.5	19.8	22.0	18	32	46	(stroke length/3.25) + 7								
φ 32	5.5	4.5	9.5	8.5	24.3	25.5	15	32	46	(stroke length/3.25) + 7								
φ 40	7.0	6.5	11.5	10.5	28.3	29.5	12	34	46	(stroke length/3.25) + 7								

Dimensions of each mounting type are same as standard type. Refer to pages 96 to 101.

SCP*2
CMK2
CMA2
SCM
SCG
SCA2
SCS
CKV2
CA/OV2
SSD
CAT
MDC2
MVC
SMD2
MSD*
FC*
STK
ULK*
JSK/M2
JSG
JSC3
USSD
USC
JSB3
LMB
STG
STS/L
LCS
LCG
LCM
LCT
LCY
STR2
UCA2
HCM
HCA
SRL2
SRG
SRM
SRT
MRL2
MRG2
SM-25
CAC3
UCAC
RCC2
MFC
SHC
GLC
Ending

Medium bore size cylinder
Standard type

SCP*2
CMK2
 CMA2
 SCM
 SCG
 SCA2
 SCS
 CKV2
 CA/OV2
 SSD
 CAT
 MDC2
 MVC
 SMD2
 MSD*
 FC*
 STK
 ULK*
 JSK/M2
 JSG
 JSC3
 USSD
 USC
 JSB3
 LMB
 STG
 STS/L
 LCS
 LCG
 LCM
 LCT
 LCY
 STR2
 UCA2
 HCM
 HCA
 SRL2
 SRG
 SRM
 SRT
 MRL2
 MRG2
 SM-25
 CAC3
 UCAC
 RCC2
 MFC
 SHC
 GLC
 Ending

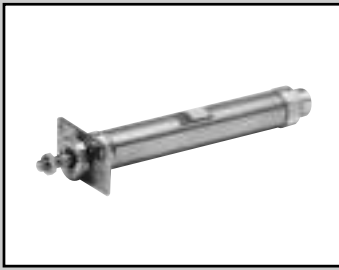

Medium bore size cylinder
 Double acting, low hydraulic type

CMK2-H Series

● Bore size: ϕ 20, ϕ 25, ϕ 32, ϕ 40

JIS symbol ● Double acting cylinder single rod type



Specifications

Descriptions		CMK2-H			
Bore size	mm	ϕ 20	ϕ 25	ϕ 32	ϕ 40
Actuation		Double acting low hydraulic type			
Working fluid		Hydraulic fluid			
Max. working pressure	MPa	1.0			
Min. working pressure	MPa	0.15			
Withstanding pressure	MPa	1.6			
Ambient temperature	°C	5 to 50			
Port size		Rc1/8			
Stroke tolerance	mm	$^{+2.0}_0$ (up to 200), $^{+2.4}_0$ (over 200)			
Working piston speed	mm/s	5 to 300			
Cushion		Rubber cushion			
Lubrication		Not required			
Allowable energy absorption	J	0.166	0.308	0.424	0.639

● Product weight, thrust and dimensions are same as CMK2 (standard type).

Stroke length

Bore size (mm)	Standard stroke length (mm)	Max. stroke length (mm)	Min. stroke length (mm)
ϕ 20	25, 50, 75, 100, 150, 200, 250, 300	750	5
ϕ 25			
ϕ 32			
ϕ 40			

Note 1: Custom stroke length is available per 1 mm increment.
 Note 2: For single foot type (LS type), maximum stroke length is 50 mm.
 Note 3: For bellows "J" type, stroke length should be longer than 25 mm.
 Consult with CKD when stroke length is shorter than 25 mm.

Min. stroke length of type with switch

(Unit: mm)

Switch quantity	1					2				3			
	Proximity		Reed			Proximity		Reed		Proximity		Reed	
	T2, T3	T1, T*Y*	T0, T5	T8	T2, T3	T1, T*Y*	T0, T5	T8	T2, T3	T1, T*Y*	T0, T5	T8	
Bore size (mm)													
ϕ 20	10					25	35	25	35	50	55	50	55
ϕ 25	10					25	35	25	35	50	55	50	55
ϕ 32	10					25	35	25	35	50	55	50	55
ϕ 40	10					25	35	25	35	50	55	50	55

Note 1: Up to three switches can be mounted.

- SCP*2
- CMK2**
- CMA2
- SCM
- SCG
- SCA2
- SCS
- CKV2
- CA/OV2
- SSD
- CAT
- MDC2
- MVC
- SMD2
- MSD*
- FC*
- STK
- ULK*
- JSK/M2
- JSG
- JSC3
- USSD
- USC
- JSB3
- LMB
- STG
- STS/L
- LCS
- LCG
- LCM
- LCT
- LCY
- STR2
- UCA2
- HCM
- HCA
- SRL2
- SRG
- SRM
- SRT
- MRL2
- MRG2
- SM-25
- CAC3
- UCAC
- RCC2
- MFC
- SHC
- GLC

Switch specifications

● 1 color/2 color indicator

* The T0/T5 switch can be used with 220 VAC. Contact CKD for working conditions.

Descriptions	Proximity 2-wire			Proximity 3-wire			Reed 2-wire						
	T1H/T1V	T2H/T2V/ T2JH/T2JV	T2YH/T2YV	T3H/T3V	T3PH/T3PV (Custom order)	T3YH/T3YV	TOH/TOV		T5H/T5V		T8H/T8V		
Applications	Programmable controller Relay, small solenoid valve		Programmable controller dedicated	Programmable controller, relay			Programmable controller, relay		Programmable controller, relay, IC circuit (w/o light), serial connection		Programmable controller, relay		
Output method	-			NPN output	PNP output	NPN output	-						
Power voltage	-			10 to 28 VDC			-						
Load voltage	85 to 265 VAC		10 to 30 VDC	30 VDC or less			12/24 VDC	110 VAC	5/12/24 VDC	110 VAC	12/24 VDC	110 VAC	220 VAC
Load current	5 to 100 mA		5 to 20 mA (Note 1)	100 mA or less		50 mA or less	5 to 50 mA	7 to 20 mA	50 mA or less	20 mA or less	5 to 50 mA	7 to 20 mA	7 to 10 mA
Light	LED (ON lighting)		LED (ON lighting)	Red/green LED (ON lighting)	LED (ON lighting)	Green LED (ON lighting)	Red/Green LED (ON lighting)	LED (ON lighting)		Without indicator light		LED (ON lighting)	
Leakage current	1 mA or less with 100 VAC 2 mA or less with 200 VAC		1 mA or less	10 μA or less			0 mA						

● With preventive maintenance output

Descriptions	Proximity 3-wire		Proximity 4-wire		Proximity 3-wire		Proximity 4-wire	
	T2YFH/V		T3YFH/V		T2YMH/V		T3YMH/V	
Applications	Programmable controller dedicated		Programmable controller, relay		Programmable controller dedicated		Programmable controller, relay	
Output method	NPN output							
Light	Red/Green LED (ON lighting)							
	Installation position adjustment		-		Yellow LED (ON lighting)			
Regular Output section	Power voltage		10 to 28 VDC		-		10 to 28 VDC	
	Load voltage		30 VDC or less		10 to 30 VDC		30 VDC or less	
	Load current		50 mA or less		5 to 20 mA		50 mA or less	
	Leakage current		10 μA or less		1.2 mA or less		10 μA or less	
Preventive maintenance Output section	30 VDC or less							
	Load voltage		50 mA or less		5 to 20 mA or less		50 mA or less	
	Load current		10 μA or less					

Note 1: Refer to Ending 1 for other switches.

Note 2: The above maximum load current of 20 mA applies at 25 °C. If the switch's working ambient temperature exceeds 25 °C, the load current will be lower than 20 mA. (5 to 10 mA when 60 °C)

Cylinder weight

(Unit: kg)

Descriptions/mounting style	Product weight when stroke length (S) = 0 mm								Switch weight	Switch rail + band weight	Additional weight per S = 10 mm
	Basic type (00)	Axial foot type (LB)	Axial foot type (LS)	Flange type (FA/FB)	Eye bracket type (CA)	Clevis type (CC)	Clevis bracket type (CB)	Trunnion type (TA/TB)	Grommet		
φ20	0.17	0.32	0.25	0.23	0.32	0.18	0.32	0.22	0.018	0.005	0.01
φ25	0.26	0.52	0.39	0.41	0.50	0.26	0.50	0.36	0.018	0.005	0.01
φ32	0.30	0.56	0.43	0.45	0.54	0.30	0.54	0.40	0.018	0.009	0.02
φ40	0.48	0.74	0.61	0.63	0.72	0.50	0.72	0.64	0.018	0.009	0.02

(E.g.) Product weight of
CMK2-H-FA-32-50-T0H-D

When S = 0 mm, product weight is 0.45 kg

Additional weight at S = 50 mm is additional weight at S = 10 mm $0.02 \times \frac{\text{Product stroke length (50)}}{10} = 0.10$ kg

Weight of two switches is 0.036 kg

Weight of switch rail and two bands is 0.018 kg

Product weight is 0.45 kg + 0.1 kg + 0.036 kg + 0.018 kg = 0.604 kg

Ending
Medium bore size cylinder
Standard type

- SCP*2
- CMK2**
- CMA2
- SCM
- SCG
- SCA2
- SCS
- CKV2
- CA/OV2
- SSD
- CAT
- MDC2
- MVC
- SMD2
- MSD*
- FC*
- STK
- ULK*
- JSK/M2
- JSG
- JSC3
- USSD
- USC
- JSB3
- LMB
- STG
- STS/L
- LCS
- LCG
- LCM
- LCT
- LCY
- STR2
- UCA2
- HCM
- HCA
- SRL2
- SRG
- SRM
- SRT
- MRL2
- MRG2
- SM-25
- CAC3
- UCAC
- RCC2
- MFC
- SHC
- GLC
- Ending

How to order

Without switch

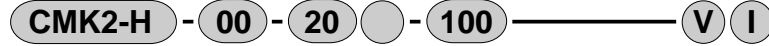

With switch

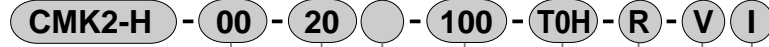

A Mounting style
Note 1

B Bore size

C Port thread type

D Stroke length

E Switch model no.

Note on model no. selection

- Note 1: The maximum stroke of the single-end foot type (LS type) is 50 mm.
- Note 2: Refer to page 178 for min. stroke length with switch.
- Note 3: For bellows "J" type, stroke length should be longer than 25 mm. Consult with CKD when stroke length is shorter than 25 mm.
- Note 4: Instantaneous maximum temperature is the temperature when spark and spatter etc. instantaneously contacts to bellows.
- Note 5: "I" "Y" can not be selected at the same time.
- Note 6: Refer to Ending 89 for custom specifications of rod end form.**
- Note 7: Refer to page 84 for variation and combinations of options.
- Note 8: Up to three switches can be mounted. If more than four switches are required, switch mounting brackets for the extra switches must be prepared separately.

<Example of model number>

CMK2-H-00-20-100-T0H-R-VI

Model: Medium bore size cylinder, double acting, low hydraulic type

- A** Mounting style : Basic type
- B** Bore size : ϕ 20 mm
- C** Port thread type : Rc thread
- D** Stroke length : 100 mm
- E** Switch model no. : Reed T0H switch and lead wire 1 m
- F** Switch quantity : One on rod end
- G** Option : Boss cut off
- H** Accessory : Rod eye

F Switch quantity
Note 8

G Option
Note 3, Note 4

H Accessory
Note 5

Symbol	Descriptions
A Mounting style	
00	Basic type
LB	Axial foot type (both sides)
LS	Axial foot type (single)
FA	Rod side flange type
FB	Head side flange type
CA	Eye bracket type
CC	Fixed eye
CC1	Eye and bush press fitted type
CB	Clevis bracket type (pin and washer split pin attached)
TA	Rod side trunnion type
TB	Head side trunnion type

B Bore size (mm)	
20	ϕ 20
25	ϕ 25
32	ϕ 32
40	ϕ 40

C Port thread type	
Blank	Rc thread
NN	NPT thread (custom order)
GN	G thread (custom order)

D Stroke length (mm)		
Bore size	Stroke length Note 2	Custom stroke length
ϕ 20	5 to 750	By 1 mm increment
ϕ 25	5 to 750	
ϕ 32	5 to 750	
ϕ 40	5 to 750	

E Switch model no.				
Lead wire	Lead wire	Contact	Indicator	Lead wire
Straight type	L type			
T0H*	T0V*	Reed	1 color indicator type	2-wire
T5H*	T5V*		Without indicator light	
T8H*	T8V*		1 color indicator type	
T1H*	T1V*	Proximity	1 color indicator type	2-wire
T2H*	T2V*			
T3H*	T3V*			
T3PH*	T3PV*		1 color indicator type (custom order)	3-wire
T2YH*	T2YV*		2 color indicator type	
T3YH*	T3YV*		2 color indicator type (w/o light for preventive maintenance output)	
T2YMH*	T2YMV*	2 color indicator type (Light available for preventive maintenance output (1 color))	3-wire	4 wire
T3YMH*	T3YMV*		4 wire	
T2JH*	T2JV*		Off-delay type	

* Lead wire length	
Blank	1 m (standard)
3	3 m (option)
5	5 m (option)

F Switch quantity	
R	One on rod end
H	One on head end
D	Two
T	Three

G Option			
		Max. ambient	Max. instantaneous
J	Bellows	100 °C	200 °C
L	Bellows	250 °C	400 °C
M	Piston rod material (stainless steel)		
V	Boss cut off		
P6	Copper and PTFE free		

H Accessory	
I	Rod eye
Y	Rod clevis (pin and washer split pin attached)
B2	Clevis bracket (pin and snap ring attached)

How to order switch

- Switch body + mounting bracket

CMK2 - **T0H** - **20**

Bore size (item ⑤ on previous page)

Switch model no. (item ④ on previous page)

- Only switch body

SW - **T0H**

Switch model no. (item ④ on previous page)

- Mounting bracket

CMK2 - **T** - **20**

Bore size (item ⑤ on previous page)

Bracket

How to order mounting bracket

Bore size (mm)	φ20	φ25	φ32	φ40
Mounting bracket				
Axial foot type (LB/LS)	M1-LB-20	M1-LB-30	M1-LB-30	M1-LB-30
Flange (FA/FB)	M1-FA-20	M1-FA-30	M1-FA-30	M1-FA-30
Trunnion (TA/TB)	M1-TA-20	M1-TA-30	M1-TA-30	M1-TA-40
Eye bracket type (CA)	M1-CA-20	M1-CA-30	M1-CA-30	M1-CA-30
Clevis bracket type (CB)	M1-CB-20	M1-CB-30	M1-CB-30	M1-CB-30

Note 1: Mounting nut/toothed washer are attached to each mounting bracket.

Note 2: Two sets of "M1-LB-20" in the above table are required for the axial direction foot (double-sided).

Internal structure drawing

This is the same as the standard type. Refer to Page 94.

Dimensions

This is the same as the standard type. Refer to pages 95 to 101.

SCP*2
CMK2
CMA2
SCM
SCG
SCA2
SCS
CKV2
CA/OV2
SSD
CAT
MDC2
MVC
SMD2
MSD*
FC*
STK
ULK*
JSK/M2
JSG
JSC3
USSD
USC
JSB3
LMB
STG
STS/L
LCS
LCG
LCM
LCT
LCY
STR2
UCA2
HCM
HCA
SRL2
SRG
SRM
SRT
MRL2
MRG2
SM-25
CAC3
UCAC
RCC2
MFC
SHC
GLC
Ending

Medium bore size cylinder
Standard type

SCP*2
CMK2
 CMA2
 SCM
 SCG
 SCA2
 SCS
 CKV2
 CA/OV2
 SSD
 CAT
 MDC2
 MVC
 SMD2
 MSD*
 FC*
 STK
 ULK*
 JSK/M2
 JSG
 JSC3
 USSD
 USC
 JSB3
 LMB
 STG
 STS/L
 LCS
 LCG
 LCM
 LCT
 LCY
 STR2
 UCA2
 HCM
 HCA
 SRL2
 SRG
 SRM
 SRT
 MRL2
 MRG2
 SM-25
 CAC3
 UCAC
 RCC2
 MFC
 SHC
 GLC
 Ending

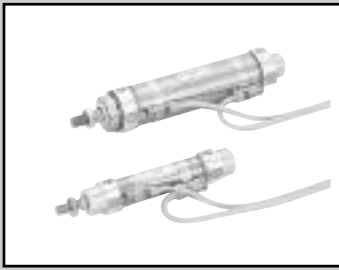

Medium bore size cylinder double acting coolant proof type

CMK2-G2/G3 Series

● Bore size: ϕ 20, ϕ 25, ϕ 32, ϕ 40

JIS symbol



Specifications

Descriptions		CMK2-G2/G3			
Bore size	mm	ϕ 20	ϕ 25	ϕ 32	ϕ 40
Actuation		Double acting coolant proof type			
Working fluid		Compressed air			
Max. working pressure	MPa	1.0			
Min. working pressure	MPa	0.15			
Withstanding pressure	MPa	1.6			
Ambient temperature		-10 to 60 (no freezing)			
Port size		Rc1/8			
Stroke tolerance	mm	$^{+2.0}_0$ (0 to 200) $^{+2.4}_0$ (over 200)			
Working piston speed	mm/s	50 to 500			
Cushion		Rubber cushion			
Lubrication		Not required (when lubricating, use turbine oil Class 1 ISO VG32.)			
Allowable energy absorption	J	0.166	0.308	0.424	0.639

Stroke length

Bore size (mm)	Standard stroke length (mm)	Max. stroke length (mm)	Min. stroke length (mm)	Min. stroke length with switch (mm)
ϕ 20, ϕ 25, ϕ 32, ϕ 40	25, 50, 75, 100, 150, 200, 250, 300	750	5	25

Note 1: Custom stroke length is available per 1 mm increment.

Note 2: For single foot type (LS type), maximum stroke length is 50 mm.

Switch specifications

Type/model no.	Proximity switch specifications	
Descriptions	T2YLH/T2YLV	T3YLH/T3YLV
	Applications	Programmable controller dedicated
Output method	-	NPN output
Power voltage	-	10 to 28 VDC
Load voltage and current	10 to 30 VDC and 5 to 20 mA Note 1	30 VDC or less, 50 mA or less
Light	Red/Green LED (ON lighting)	
Leakage current	1 mA or less	10 μ A or less
Maximum shock resistance	980 m/S ²	

Note 1: Maximum load current above: 20 mA at 25 °C .

The current will be lower than 20 mA if ambient temperature around switch is higher than 25 °C .(5 to 10 mA at 60 °C)

Cylinder weight

(Unit: kg)

Descriptions/mounting style	Product weight when stroke length (S) = 0 mm								Switch weight	Switch rail + band weight	Additional weight per S = 10 mm
	Basic type (00)	Axial foot type (LB)	Axial foot type (LS)	Flange type (FA/FB)	Eye bracket type (CA)	Clevis type (CC)	Clevis bracket type (CB)	Trunnion type (TA/TB)	Grommet		
ϕ 20	0.21	0.36	0.29	0.27	0.36	0.22	0.36	0.26	0.031	0.005	0.01
ϕ 25	0.27	0.53	0.40	0.42	0.51	0.27	0.51	0.37	0.031	0.005	0.01
ϕ 32	0.31	0.57	0.44	0.46	0.55	0.31	0.55	0.41	0.031	0.009	0.02
ϕ 40	0.49	0.75	0.62	0.64	0.73	0.51	0.73	0.65	0.031	0.009	0.02

(E.g.) Product weight of CMK2-G2-FA-32-50-T2YL-D

When S = 0 mm, product weight is 0.45 kg

Additional weight at S = 50 mm is additional weight at S = 10 mm $0.02 \times \frac{\text{Product stroke length (50)}}{10} = 0.10$ kg

Weight of two switches is 0.062 kg

Weight of switch rail and two bands is 0.018 kg

Product weight is 0.45 kg + 0.1 kg + 0.062 kg + 0.018 kg = 0.63 kg

- SCP*2
- CMK2
- CMA2
- SCM
- SCG
- SCA2
- SCS
- CKV2
- CA/OV2
- SSD
- CAT
- MDC2
- MVC
- SMD2
- MSD*
- FC*
- STK
- ULK*
- JSK/M2
- JSG
- JSC3
- USSD
- USC
- JSB3
- LMB
- STG
- STS/L
- LCS
- LCG
- LCM
- LCT
- LCY
- STR2
- UCA2
- HCM
- HCA
- SRL2
- SRG
- SRM
- SRT
- MRL2
- MRG2
- SM-25
- CAC3
- UCAC
- RCC2
- MFC
- SHC
- GLC
- Ending

Medium bore size cylinder
Standard type

CMK2-G2/G3 Series

How to order

Without switch

CMK2 - G2 - 00 - 20 - 100 - Y

With switch

CMK2 - G2 - 00 - 20 - 100 - T2YLH - R - Y

A Protective structure

B Mounting style
Note 1

C Bore size

D Port thread type

E Stroke length

F Switch model no.
*Indicates lead wire

G Switch quantity
Note 5

H Accessory
Note 3

Symbol	Descriptions
A Protective structure	
G2	Coolant proof scraper + packing seal NBR
G3	Coolant proof scraper + packing seal FKM

B Mounting style	
00	Basic type
LB	Axial foot type (both sides)
LS	Axial foot type (single)
FA	Rod side flange type
FB	Head side flange type
CA	Eye bracket type
CC	Fixed eye
CC1	Eye bracket bush press fitted types
CB	Clevis bracket type (pin and washer split pin attached)
TA	Rod side trunnion type
TB	Head side trunnion type

C Bore size (mm)		
20	φ 20	
25	φ 25	
32	φ 32	
40	φ 40	

D Port thread type	
Blank	Rc thread
NN	NPT thread (custom order)
GN	G thread (custom order)

E Stroke length (mm)		
Bore size	Stroke length Note 2	Custom stroke length
φ 20	5 to 750	By 1 mm increment
φ 25	5 to 750	
φ 32	5 to 750	
φ 40	5 to 750	

F Switch model no.				
Lead wire Straight type	Lead wire L type	Contact	Indicator	Lead wire
T2YLH*	T2YLV*	Proximity	2 color	2-wire
T3YLH*	T3YLV*		indicator type	3-wire
* Lead wire length				
Blank	1 m (standard)			
3	3 m (option)			
5	5 m (option)			

G Switch quantity	
R	One on rod end
H	One on head end
D	Two
T	Three

H Accessory	
I	Rod eye
Y	Rod clevis (pin and washer split pin attached)
B2	Clevis bracket (pin and snap ring attached)

⚠ Note on model no. selection

Note 1: The maximum stroke of the single-end foot type (LS type) is 50 mm.

Note 2: Refer to page 182 for min. stroke length with switch.

Note 3: "I" and "Y" can not be selected at the same time.

Note 4: Refer to page 84 for variation and combinations of options.

Note 5: Up to three switches can be mounted. If more than four switches are required, switch mounting brackets for the extra switches must be prepared separately.

<Example of model number>

CMK2-G2-FA-32-100-T2YLH-R-Y

Model: Medium bore size cylinder

A Protective structure : Coolant proof scraper + packing seal NBR

B Mounting style : Rod side flange type

C Bore size : φ 32 mm

D Port thread type : Rc thread

E Stroke length : 100 mm

F Switch model no. : Proximity switch T2YLH and lead wire 1 m

G Switch quantity : One on rod side

H Accessory : Rod clevis

How to order switch

- Switch body + mounting bracket

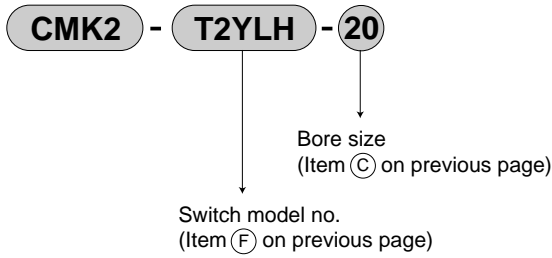

- Mounting bracket

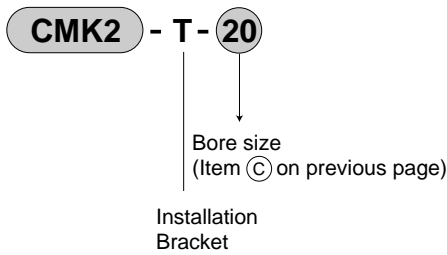

- Only switch body

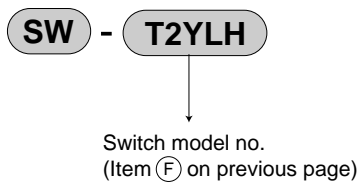

How to order mounting bracket

Bore size (mm)	φ 20	φ 25	φ 32	φ 40
Axial foot type (LB/LS)	M1-LB-20	M1-LB-30	M1-LB-30	M1-LB-30 CMK2-G2-40-LS (rod side of LB)
Flange (FA/FB)	M1-FA-20	M1-FA-30	M1-FA-30	CMK2-G2-40-FA (FA) M1-FA-30 (FB)
Trunnion (TA/TB)	M1-TA-20	M1-TA-30	M1-TA-30	CMK2-G2-40-TA (TA) M1-TA-40 (TB)
Eye bracket type (CA)	M1-CA-20	M1-CA-30	M1-CA-30	M1-CA-30
Clevis bracket type (CB)	M1-CB-20	M1-CB-30	M1-CB-30	M1-CB-30

Note 1: The nut, LS fitting (LB rod side), FA fitting, and TA fitting enclosed with the rod cover for the tubing bore size φ40 differ from the standard type.

Note 2: Mounting nut/toothed washer are attached to each mounting bracket.

Note 3: Two sets of "M1-LB-*" in the above table are required for the axial direction foot (double-sided).

SCP*2
CMK2
CMA2
SCM
SCG
SCA2
SCS
CKV2
CA/OV2
SSD
CAT
MDC2
MVC
SMD2
MSD*
FC*
STK
ULK*
JSK/M2
JSG
JSC3
USSD
USC
JSB3
LMB
STG
STS/L
LCS
LCG
LCM
LCT
LCY
STR2
UCA2
HCM
HCA
SRL2
SRG
SRM
SRT
MRL2
MRG2
SM-25
CAC3
UCAC
RCC2
MFC
SHC
GLC
Ending

Medium bore size cylinder
Standard type

CMK2-G2/G3 Series

Internal structure and parts list

- SCP*2
- CMK2**
- CMA2
- SCM
- SCG
- SCA2
- SCS
- CKV2
- CA/OV2
- SSD
- CAT
- MDC2
- MVC
- SMD2
- MSD*
- FC*
- STK
- ULK*
- JSK/M2
- JSG
- JSC3
- USSD
- USC
- JSB3
- LMB
- STG
- STS/L
- LCS
- LCG
- LCM
- LCT
- LCY
- STR2
- UCA2
- HCM
- HCA
- SRL2
- SRG
- SRM
- SRT
- MRL2
- MRG2
- SM-25
- CAC3
- UCAC
- RCC2
- MFC
- SHC
- GLC

- Protective structure: Packing seal NBR
CMK2-G2
- Protective structure: Packing seal FKM
CMK2-G3

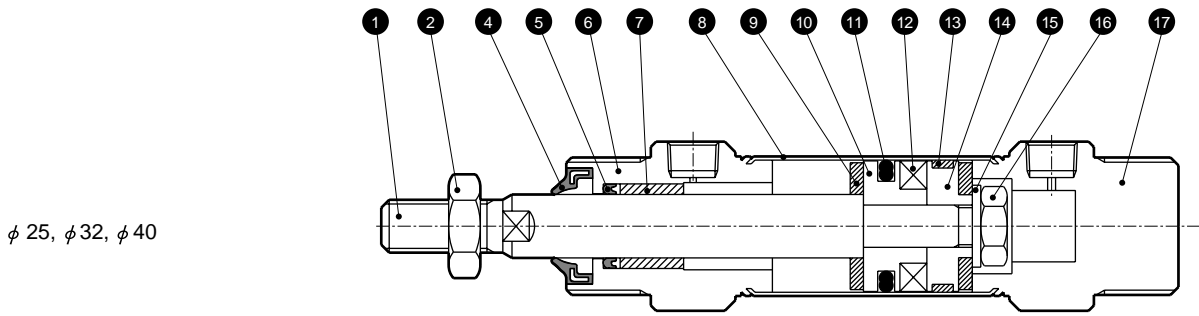
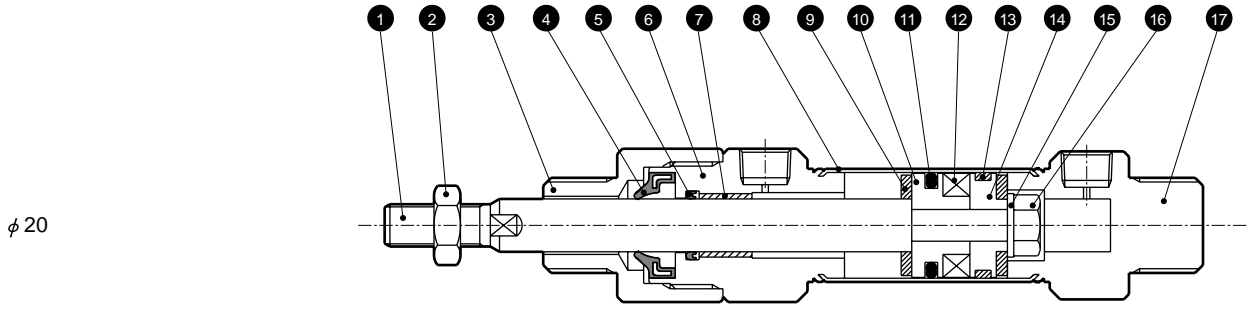

Note: This caulking type cannot be disassembled.

No.	Parts name	Material	Remarks	No.	Parts name	Material	Remarks
1	Piston rod	Stainless steel	Industrial chrome plating	9	Cushion rubber	Urethane rubber	
2	Hexagon nut	Stainless steel		10	Piston A	Aluminum alloy	Chromate treatment
3	Adaptor	Aluminum alloy	Chromate treatment	11	Piston packing seal	G2 Nitrile rubber	
4	Scraper	G2 Nitrile rubber		12		Magnet	Plastic
		G3 Fluorine rubber		13	Wear ring	Polyacetal	
5	Rod packing seal	G2 Nitrile rubber		14	Piston B	Aluminum alloy	Chromate treatment
		G3 Fluorine rubber		15	Spacer	Steel	Zinc chromate plating
6	Rod cover	Aluminum alloy	Chromate treatment	16	Hexagon nut	Steel	Zinc chromate plating
7	Bush	φ20: DU dry pair ring		17	Bed spread	Aluminum alloy	Chromate treatment
		φ 25, φ 32, φ 40: Copper					
8	Cylinder tube	Stainless steel					

Dimensions

- T type basic type (00) $\phi 20$ with switch

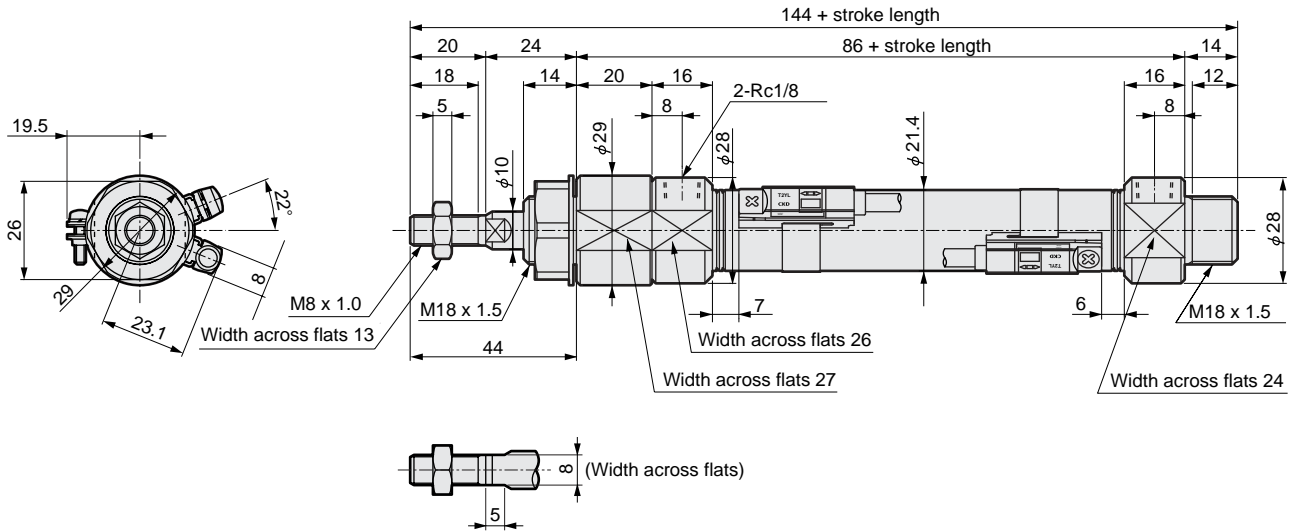

* The width across flats position of the adapter is not specified.

- T type basic type (00) $\phi 25$, $\phi 32$, $\phi 40$ with switch

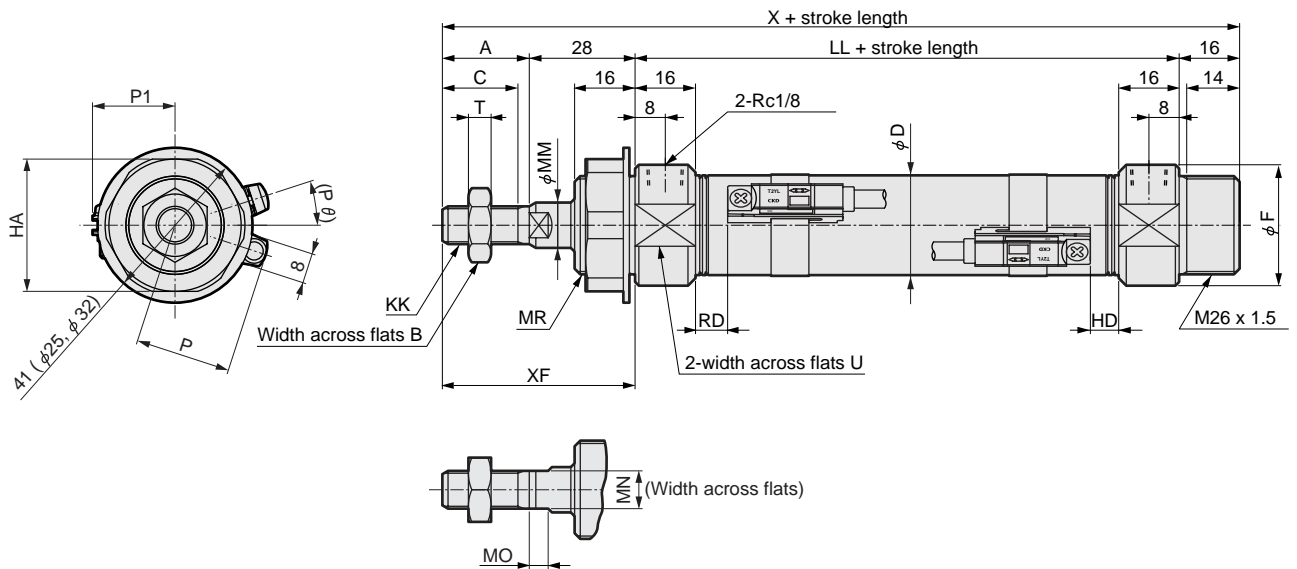

Note 1: Toothed washer is not enclosed for $\phi 40$.
 Note 2: Refer to page 190 for dimensions of accessories.

Symbol	Basic dimensions of basic type (00)															
Bore size (mm)	A	B	C	D	F	HA	KK	LL	MM	MN	MO	MR	T	U	X	XF
$\phi 25$	23	17	20	26.4	32	35	M10 x 1.25	69	12	10	5	M26 x 1.5	6	30	136	51
$\phi 32$	23	17	20	33.6	36	35	M10 x 1.25	69	12	10	5	M26 x 1.5	6	34	136	51
$\phi 40$	25	19	22	41.6	45	38	M12 x 1.5	73	14	12	6	M30 x 1.5	7	43	142	53

Symbol	With switch				
Bore size (mm)	RD	HD	P	(P θ) ^o	P1
$\phi 25$	8.5	7.5	25.6	18	22.0
$\phi 32$	8.5	7.5	30.1	15	25.5
$\phi 40$	10.5	9.5	34.1	12	29.5

- SCP*2
- CMK2**
- CMA2
- SCM
- SCG
- SCA2
- SCS
- CKV2
- CA/OV2
- SSD
- CAT
- MDC2
- MVC
- SMD2
- MSD*
- FC*
- STK
- ULK*
- JSK/M2
- JSG
- JSC3
- USSD
- USC
- JSB3
- LMB
- STG
- STS/L
- LCS
- LCG
- LCM
- LCT
- LCY
- STR2
- UCA2
- HCM
- HCA
- SRL2
- SRG
- SRM
- SRT
- MRL2
- MRG2
- SM-25
- CAC3
- UCAC
- RCC2
- MFC
- SHC
- GLC
- Ending

Medium bore size cylinder
Standard type

CMK2 series common (T1*, T8*, 2 color indicator type, with preventive maintenance output, with switch) dimensions

● CMK2-**-**-T₃YH/V, T₃YFH/V, T₃YMH/V

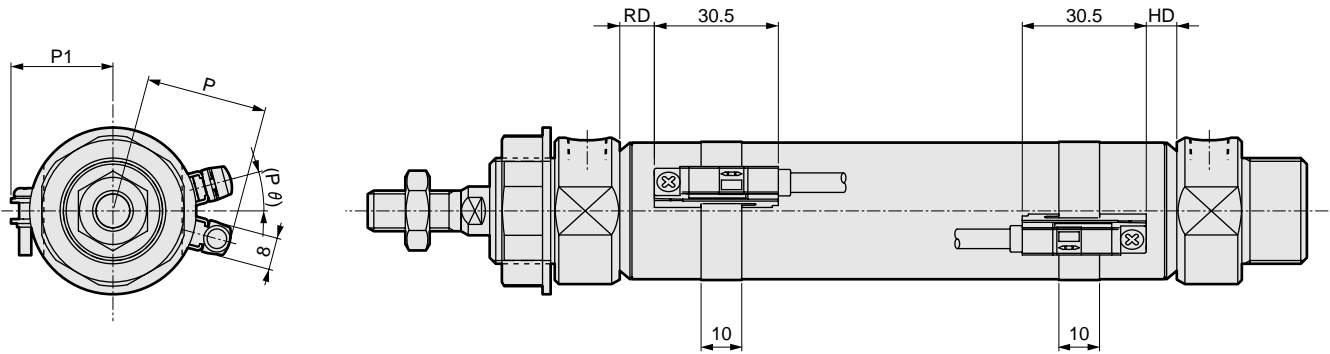

Mounting dimensions for 2-color indication switch with preventive maintenance output

Symbol	1 color indicator (T1, T8) 2-color indicator (T ₃ ² Y, T ₃ ² Y _M ^F)								
	RD Note 1		HD Note 2		P			P1	(Pθ)°
	T1/T ₃ ² Y/T ₃ ² Y _M ^F	T8	T1/T ₃ ² Y/T ₃ ² Y _M ^F	T8	T1	T ₃ ² Y/T8	T ₃ ² Y _M ^F		
Bore size (mm)									
φ20	7.0	2.0	6.0	1	28.5	23.1	28.1	19.5	22
φ25	8.5	3.5	7.5	2.5	31.0	25.6	30.6	22.0	18
φ32	8.5	3.5	7.5	2.5	35.5	30.1	35.1	25.5	15
φ40	10.5	5.5	9.5	4.5	39.5	34.1	39.1	29.5	12

Note 1: RD dimension of CMK2-S is below table 1.

Note 2: HD dimension of CMK2-SR is below table 2.

Table 1

Symbol	RD													
	T1/T ₃ ² Y/T ₃ ² Y _M ^F							T8						
	25 or less	25 to 50	50 to 100	100 to 150	150 to 200	200 to 250	250 to 300	25 or less	25 to 50	50 to 100	100 to 150	150 to 200	200 to 250	250 to 300
Bore size (mm)														
φ20	32.0	34.0	61.0	88.0	115.0	142.0	169.0	27.0	29.0	56.0	83.0	110.0	137.0	164.0
φ25	33.5	38.5	68.5	98.5	128.5	158.5	188.5	28.5	33.5	63.5	93.5	123.5	153.5	183.5
φ32	33.5	38.5	68.5	98.5	128.5	158.5	188.5	28.5	33.5	63.5	93.5	123.5	153.5	183.5
φ40	35.5	40.5	70.5	100.5	130.5	160.5	190.5	30.5	35.5	65.5	95.5	125.5	155.5	185.5

Table 2

Symbol	HD													
	T1/T ₃ ² Y/T ₃ ² Y _M ^F							T8						
	25 or less	25 to 50	50 to 100	100 to 150	150 to 200	200 to 250	250 to 300	25 or less	25 to 50	50 to 100	100 to 150	150 to 200	200 to 250	250 to 300
Bore size (mm)														
φ20	31.0	33.0	60.0	87.0	114.0	141.0	168.0	26.0	28.0	55.0	82.0	109.0	136.0	163.0
φ25	32.5	37.5	67.5	97.5	127.5	157.5	187.5	27.5	32.5	62.5	92.5	122.5	152.5	182.5
φ32	32.5	37.5	67.5	97.5	127.5	157.5	187.5	27.5	32.5	62.5	92.5	122.5	152.5	182.5
φ40	34.5	39.5	69.5	99.5	129.5	159.5	189.5	29.5	34.5	64.5	94.5	124.5	154.5	184.5

Dimensions with options

● Boss cut off type (V)

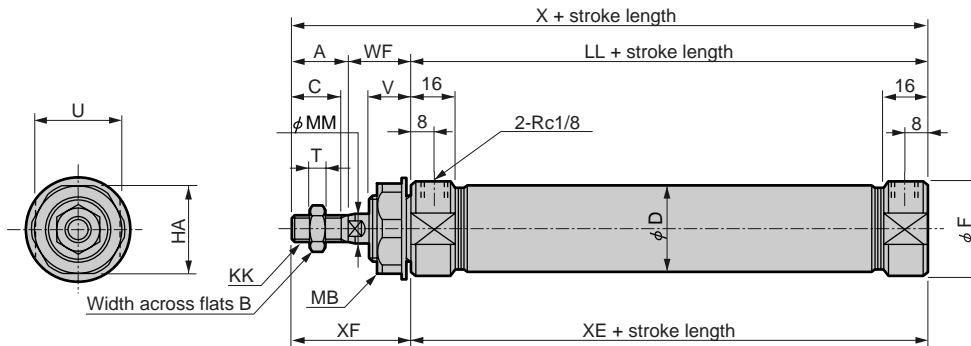

Note: Dimensions of each mounting type are same as standard type. Refer to pages 95 to 101. (Available mounting style: 00, LS, FA, TA)

Symbol	Basic type (00) basic dimensions																
Bore size (mm)	A	B	C	D	F	HA	KK	LL	MB	MM	T	U	V	WF	X	XE	XF
φ 20	20	13	18	21.4	28	26	M8 x 1.0	66	M18 x 1.5	10	5	24	14	24	110	66	44
φ 25	23	17	20	26.4	32	35	M10 x 1.25	69	M26 x 1.5	12	6	30	16	23	115	69	46
φ 32	23	17	20	33.6	36	35	M10 x 1.25	69	M26 x 1.5	12	6	34	16	23	115	69	46
φ 40	25	19	22	41.6	45	35	M12 x 1.5	73	M26 x 1.5	14	7	43	16	23	121	73	48

● Push-in joint (-F)

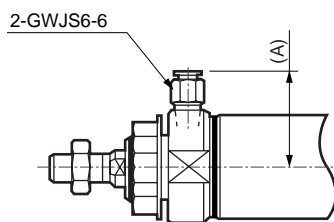

● Push-in joint (-FE)

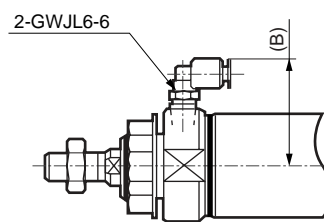

Symbol	A	B
Bore size (mm)	A	B
φ 20	30.5	34.5
φ 25	32.5	36.5
φ 32	34.5	38.5
φ 40	39	43

SCP*2
CMK2
 CMA2
 SCM
 SCG
 SCA2
 SCS
 CKV2
 CA/OV2
 SSD
 CAT
 MDC2
 MVC
 SMD2
 MSD*
 FC*
 STK
 ULK*
 JSK/M2
 JSG
 JSC3
 USSD
 USC
 JSB3
 LMB
 STG
 STS/L
 LCS
 LCG
 LCM
 LCT
 LCY
 STR2
 UCA2
 HCM
 HCA
 SRL2
 SRG
 SRM
 SRT
 MRL2
 MRG2
 SM-25
 CAC3
 UCAC
 RCC2
 MFC
 SHC
 GLC
 Ending

Medium bore size cylinder
 Standard type

CMK2 Series

Accessory (rode eye/clevis, bracket, bottle)

CMK2 Series common accessory dimensions

- SCP*2
- CMK2**
- CMA2
- SCM
- SCG
- SCA2
- SCS
- CKV2
- CA/OV2
- SSD
- CAT
- MDC2
- MVC
- SMD2
- MSD*
- FC*
- STK
- ULK*
- JSK/M2
- JSG
- JSC3
- USSD
- USC
- JSB3
- LMB
- STG
- STS/L
- LCS
- LCG
- LCM
- LCT
- LCY
- STR2
- UCA2
- HCM
- HCA
- SRL2
- SRG
- SRM
- SRT
- MRL2
- MRG2
- SM-25
- CAC3
- UCAC
- RCC2
- MFC
- SHC
- GLC
- Ending

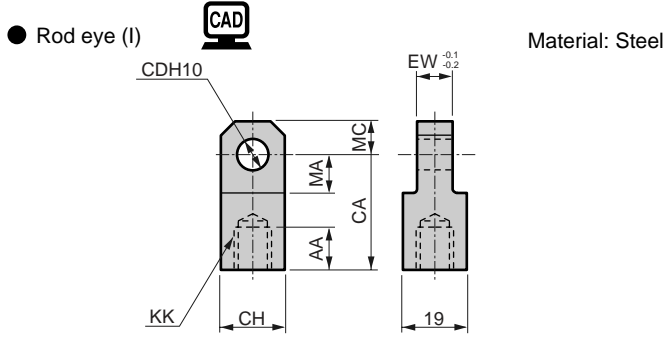

Model no.	Applicable tube Inner diameter (mm)	AA	CA	CD	CH	EW	KK	MA	MC	Mass (g)
M1-I-20	20	14	30	10 ^{+0.058/0}	19	8	M8 x 1.0	13	10	60
M1-I-30	25, 32	16	36	12 ^{+0.070/0}	25	10	M10 x 1.25	16	12	106
M1-I-40	40	14	36	12 ^{+0.070/0}	25	10	M12 x 1.5	16	12	100

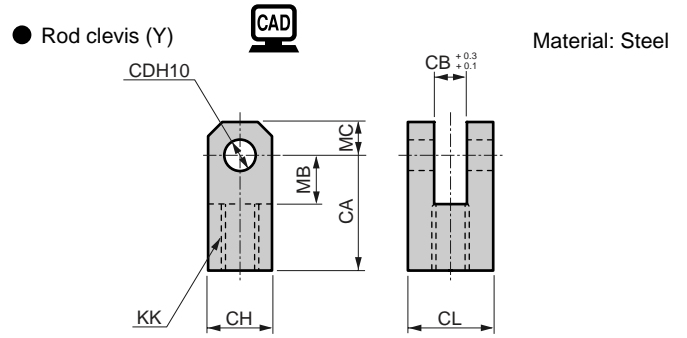

Note: A pin and washer split pin are attached.

Model no.	Applicable tube Inner diameter (mm)	CA	CB	CD	CH	CL	KK	MB	MC	Mass (g)
M1-Y-20	20	30	8	10 ^{+0.058/0}	19	19	M8 x 1.0	13	10	99
M1-Y-30	25, 32	36	10	12 ^{+0.070/0}	25	25	M10 x 1.25	16	12	197
M1-Y-40	40	36	10	12 ^{+0.070/0}	25	25	M12 x 1.5	16	12	193

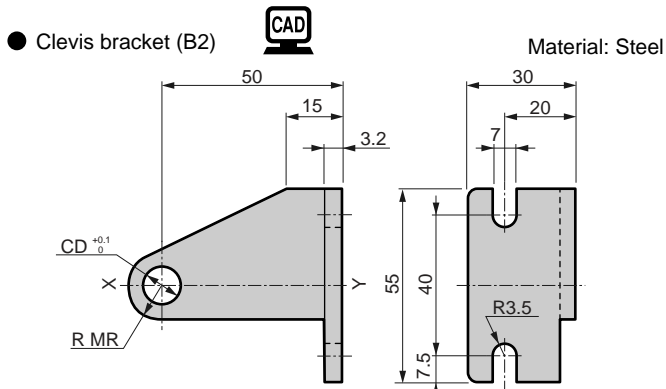

Note: The bracket symmetrical to the XY line is a pair.

Model no.	Applicable model	Applicable tube Inner diameter (mm)	CD	MR	Mass (g)
M1-B2-20-CC	CMK2-CC (Fixed eye)	20, 25	8	8	145
M1-B2-30-CC		32	10	11	163
M1-B2-40-CC		40	12	11	170
M1-B2-30-CA	CMK2-CA (Eye bracket type)	20	10	11	158
M1-B2-40-CA		25, 32, 40	12	11	162
M1-B2-20-TA	CMK2-TA/TB (Trunnion type)	20	8	8	132
M1-B2-30-TA		25, 32, 40	10	11	142

Note: Model above includes a snap ring and a pin. 2 piece/set.
(Not attached for trunnion type).

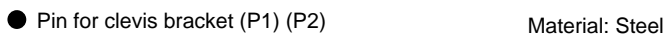

Model no.	Applicable model	Applicable tube Inner diameter (mm)	A	B	CD	D	Used snap ring	Mass (g)
M1-P1-20	CMK2-CC	20, 25	33	28	8 ^{-0.025/-0.047}	7	E type 7	13
M1-P1-30		32	33	28	10 ^{-0.025/-0.047}	9	E type 9	21
M1-P1-40		40	37	32	12 ^{-0.032/-0.059}	9	E type 9	32
M1-P2-20	CMK2-CA	20	25	20	10 ^{-0.025/-0.047}	9	E type 9	16
M1-P2-30		25, 32, 40	27	22	12 ^{-0.032/-0.059}	9	E type 9	24

Note: For bracket type, pin and snap ring are attached to the fixed eye type.
(Not attached for trunnion type).

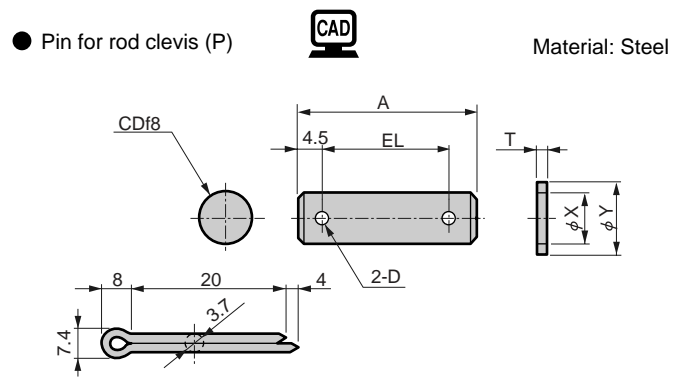

Model no.	Applicable tube Inner diameter (mm)	A	D	CD	EL	T	X	Y	Mass (g)
M1-P-20	20	37	4	10 ^{-0.013/-0.035}	28	2	10.5	18	29
M1-P-30	25, 32, 40	46	4	12 ^{-0.018/-0.043}	37	2.5	13	21	50

Note: For rod clevis type, a pin and a split pin are attached to the product.



Model no.	Applicable tube Inner diameter (mm)	B	C	KK	T	Mass (g)
M1-NR-20	20	13	15	M8 x 1.0	5	3.6
M1-NR-30	25, 32	17	19.6	M10 x 1.25	6	7.8
M1-NR-40	40	19	21.9	M12 x 1.5	7	10

Medium Bore Size Cylinder CMK2 Series

Stainless Steel Variations



TIGHT CYLINDER CMK2 SERIES



Uses food-safe grease (optional)

NSF-H1 certified product. Eliminates worries of contamination due to lubricants.



This logo marking expresses our company's stance on supporting foodstuff manufacturing processes with safe equipment by CKD.

Highly Water-Resistant Switch

Equipped with a cylinder switch designed to prevent the penetration of water.



T2YLH

High Resistance to Corrosion

External metal components are all made of stainless steel. This realizes high resistance to corrosion even in environments exposed to water.

Prevents Penetration of Water

Standard equipped with a special scraper. Prevents water from penetrating into the cylinder.

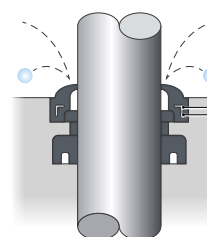

G2

A heavy duty scraper made of nitrile rubber is employed to prevent penetration

G3

In addition to G2, packing seals made of fluoro rubber that counters swelling is employed.

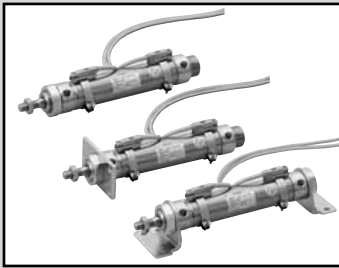

Double Acting Medium Bore Size Cylinder / Full Stainless Steel
External Body / Water Resistant

CMK2-JG2/JG3 Series

● Bore size: \varnothing 20, \varnothing 25, \varnothing 32, \varnothing 40

JIS symbol



Specifications

Description		CMK2-JG2/JG3			
		\varnothing 20	\varnothing 25	\varnothing 32	\varnothing 40
Bore size	mm	\varnothing 20	\varnothing 25	\varnothing 32	\varnothing 40
Actuation		Double Acting / Water Resistant			
Working fluid		Compressed air			
Max. working pressure	MPa	1.0			
Min. working pressure	MPa	0.15			
Proof pressure	MPa	1.6			
Ambient temperature	$^{\circ}$ C	-10 to 60 (no freezing)			
Port size		Rc 1/8			
Stroke tolerance	mm	$^{+2.0}_0$ (\leq 200 mm), $^{+2.4}_0$ ($>$ 200 mm)			
Working piston speed	mm/s	50 to 500			
Cushion		Rubber cushion			
Lubrication		Not required (use turbine oil type 1 ISO VG32 if necessary)			
Allowable energy absorption	J	0.166	0.308	0.424	0.639

Stroke length

Bore size (mm)	Standard stroke length (mm)	Max. stroke length (mm)	Min. stroke length (mm)	Min. stroke length with switch (mm)
\varnothing 20, \varnothing 25, \varnothing 32, \varnothing 40	25, 50, 75, 100, 150, 200, 250, 300	750	5	25

Note 1: Custom stroke length is available per mm.

Note 2: Single foot type (LS) has the max. stroke length of 50 mm.

Switch specifications

Type/model No. Description	Proximity switch specifications	
	T2YLH/T2YLV	T3YLH/T3YLV
Applications	Programmable controller	Programmable controller, relay
Output method	-	NPN output
Power supply voltage	-	10 to 28 VDC
Load voltage/current	10 to 30 VDC, 5 to 20 mA Note 1	30 VDC or less, 50 mA or less
Indicator lamp	Red/green LED (lights up when ON)	
Leakage current	1 mA or less	10 μA or less
Shock resistance	980 m/S ²	
Weight	g 1 m: 33 3 m: 87 5 m: 142	

Note 1: The above max. load current of 20 mA is applied at 25°C.

The current will be lower than 20 mA when the operating ambient temperature around the switch is higher than 25°C. (5 to 10 mA at 60°C)

Cylinder weight

(unit: kg)

Description Bore size (mm)	Product weight when stroke length (S) = 0 mm					Switch weight (per pc.)	Switch rail + band weight	Additional weight per S = 10 mm
	Basic type (00)	Axial foot type (LB)	Axial foot type (LS)	Flange type (FA,FB)	Eye bracket type (CC)			
φ 20	0.31	0.57	0.44	0.46	0.37	Refer to weight information provided in the switch specifications.	0.005	0.01
φ 25	0.32	0.58	0.45	0.47	0.39		0.005	0.01
φ 32	0.43	0.69	0.56	0.58	0.55		0.009	0.02
φ 40	0.65	0.91	0.78	0.80	0.90		0.009	0.02

(Example) Product weight of CMK2-JG2-FA-32-50-T2YL-D

Product weight when S = 0 mm..... 0.56 kg

Additional weight when S = 50 mm ... Additional weight when S = 10 mm $0.02 \times \frac{\text{Product stroke length (50)}}{10} = 0.10$ kg

Weight of 2 switches..... 0.062 kg

Weight of switch rail + 2 bands..... 0.018 kg

Product weight..... 0.56 kg + 0.1 kg + 0.062 kg + 0.018 kg = 0.74 kg

Theoretical thrust table

(unit: N)

Bore size (mm)	Operating direction	Working pressure MPa										
		0.1	0.15	0.2	0.3	0.4	0.5	0.6	0.7	0.8	0.9	1.0
φ 20	Push	31.4	47.1	62.8	94.2	1.26×10^2	1.57×10^2	1.88×10^2	2.20×10^2	2.51×10^2	2.83×10^2	3.14×10^2
	Pull	23.6	35.3	47.1	70.7	94.2	1.18×10^2	1.41×10^2	1.65×10^2	1.88×10^2	2.12×10^2	2.36×10^2
φ 25	Push	49.1	73.6	98.2	1.47×10^2	1.96×10^2	2.45×10^2	2.95×10^2	3.44×10^2	3.93×10^2	4.42×10^2	4.91×10^2
	Pull	37.8	56.7	75.6	1.13×10^2	1.51×10^2	1.89×10^2	2.27×10^2	2.64×10^2	3.02×10^2	3.40×10^2	3.78×10^2
φ 32	Push	80.4	1.21×10^2	1.61×10^2	2.41×10^2	3.22×10^2	4.02×10^2	4.83×10^2	5.63×10^2	6.43×10^2	7.24×10^2	8.04×10^2
	Pull	69.1	1.04×10^2	1.38×10^2	2.07×10^2	2.76×10^2	3.46×10^2	4.15×10^2	4.84×10^2	5.53×10^2	6.22×10^2	6.91×10^2
φ 40	Push	1.26×10^2	1.88×10^2	2.51×10^2	3.77×10^2	5.03×10^2	6.28×10^2	7.54×10^2	8.80×10^2	1.01×10^3	1.13×10^3	1.26×10^3
	Pull	1.10×10^2	1.65×10^2	2.21×10^2	3.31×10^2	4.41×10^2	5.51×10^2	6.62×10^2	7.72×10^2	8.82×10^2	9.92×10^2	1.10×10^3

CMK2-JG2/JG3 Series

How to order

Without switch

CMK2 - JG2 - 00 - 20 - 50

With switch

CMK2 - JG2 - 00 - 20 - 50 - T2YL - R - FP1 Y

A Variation

B Mounting style
Note 1

C Bore size

D Stroke length

E Switch model No.
* Indicates lead wire length.

F Switch quantity
Note 5

G Option

H Accessory
Note 3

Code	Description				
A Variation					
JG2	Full stainless steel ext. body + Water-resistant scraper + NBR Packing				
JG3	Full stainless steel ext. body + Water-resistant scraper + FKM Packing				
B Mounting style					
00	Basic type				
LB	Axial foot type (both-sided)				
LS	Axial foot type (single-sided)				
FA	Rod end flange type				
FB	Head end flange type				
CC	Integrated eye bracket type				
C Bore size (mm)					
20	φ 20				
25	φ 25				
32	φ 32				
40	φ 40				
D Stroke length (mm)					
Bore size	Stroke length Note 2	Custom stroke length			
φ 20	5 to 750	Per mm			
φ 25	5 to 750				
φ 32	5 to 750				
φ 40	5 to 750				
E Switch model No.					
Lead wire straight type	Lead wire L-shaped type	Contact	Voltage	Indicator	Lead wire
T2YLH*	T2YLV*	Proximity	DC	2 color display type	2 line
T3YLH*	T3YLV*				3 line
F Switch quantity					
R	1 (on rod end)				
H	1 (on head end)				
D	2				
T	3				
G Option					
Blank	Standard				
FP1	Specifications for use with food-grade grease				
V	Boss cut off				
H Accessory					
I	Rod eye				
Y	Rod clevis (pin and snap ring attached)				

⚠ Note on model No. selection

Note 1: Single foot type (LS) has the max. stroke length of 50 mm.

Note 2: Refer to page 1 for min. stroke with switch.

Note 3: "I" and "Y" cannot be selected together.

Note 4: Up to 3 switches can be mounted. If more than four switches are required, switch mounting brackets as the extra switches must be prepared separately.

[Example of model No.]

CMK2-JG2-CC-32-50-T2YLH-D-FP1Y

Model: Medium bore size cylinder

A Variation : Full stainless steel external body + Water-resistant scraper + NBR Packing

B Mounting style : Integrated eye bracket type

C Bore size : φ 32

D Stroke length : 50 mm

E Switch model No.: Proximity switch T2YLH with 1 m lead wire

F Switch quantity : 2

G Option : Specifications for use with food-grade grease

H Accessory : Rod clevis

How to order switch

● Switch body + Mounting bracket

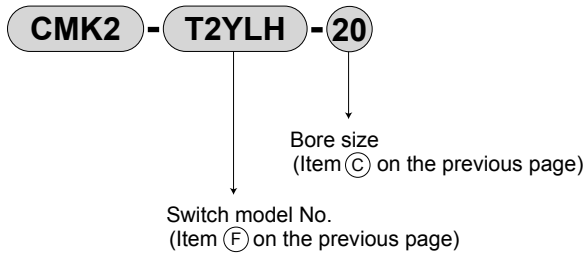

● Mounting bracket

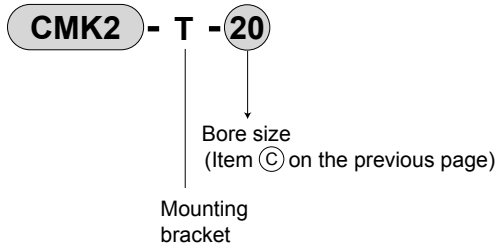

● Only switch body

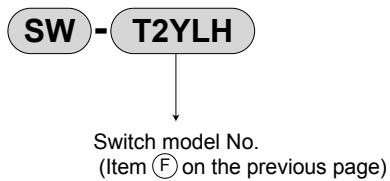

How to order mounting bracket

Bore size (mm)	φ 20	φ 25	φ 32	φ 40
Mounting bracket				
Axial foot type (LB, LS)	CMK2-JG2-20-LS	CMK2-JG2-20-LS	CMK2-JG2-20-LS	CMK2-JG2-40-LS CMK2-JG2-20-LS (head end of LB)
Flange (FA, FB)	CMK2-JG2-20-FA	CMK2-JG2-20-FA	CMK2-JG2-20-FA	CMK2-JG2-20-FA (for FB) CMK2-JG2-40-FA (for FA)

Note 1: As for mounting brackets, the axial foot type and flange type include installation nuts.

Note 2: For the axial foot type (LB), 2 sets of "CMK2-JG2-*-LS" listed in the above table are required.

CMK2-JG2/JG3 Series

Internal structure and parts list

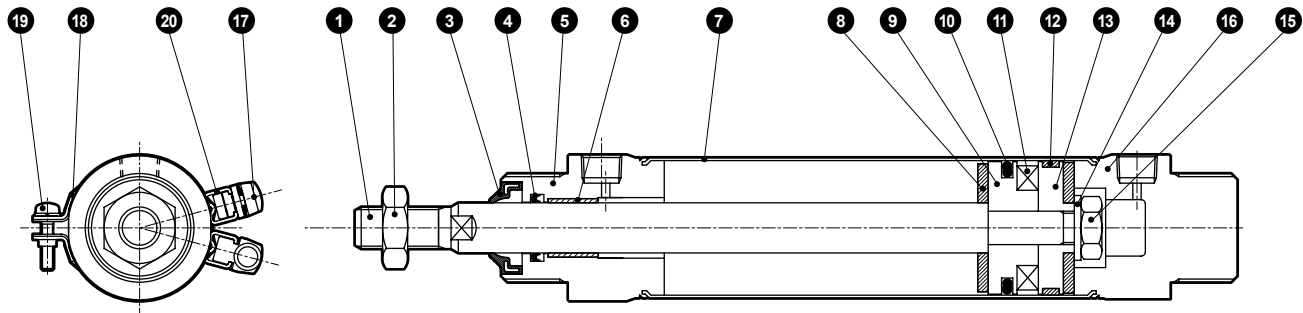

Disassembly not possible

Note : This product is a caulked type and cannot be disassembled.

No.	Parts name	Material	Remarks	No.	Parts name	Material	Remarks
1	Piston rod	Stainless steel		10	Piston packing	JG2	Nitrile rubber
2	Rod nut	Stainless steel				JG3	Fluoro rubber
3	Scraper	JG2	Nitrile rubber	11	Magnet	-	
		JG3	Fluoro rubber	12	Wear ring	Resin	
4	Rod packing	JG2	Nitrile rubber	13	Piston B	Aluminum alloy	
		JG3	Fluoro rubber	14	Spacer	Steel	Zinc chromate
5	Rod cover	Stainless steel		15	Hexagon nut	Steel	Zinc chromate
6	Bush	Dry bearing		16	Head cover	Stainless steel	
7	Cylinder tube	Stainless steel		17	Switch	-	Only with switch
8	Cushion rubber	Urethane rubber		18	Band	Stainless steel	Only with switch
9	Piston A	Aluminum alloy		19	Pan head machine screw	Stainless steel	Only with switch
				20	Switch rail	Stainless steel	Only with switch

Dimensions

● Basic type (OO)

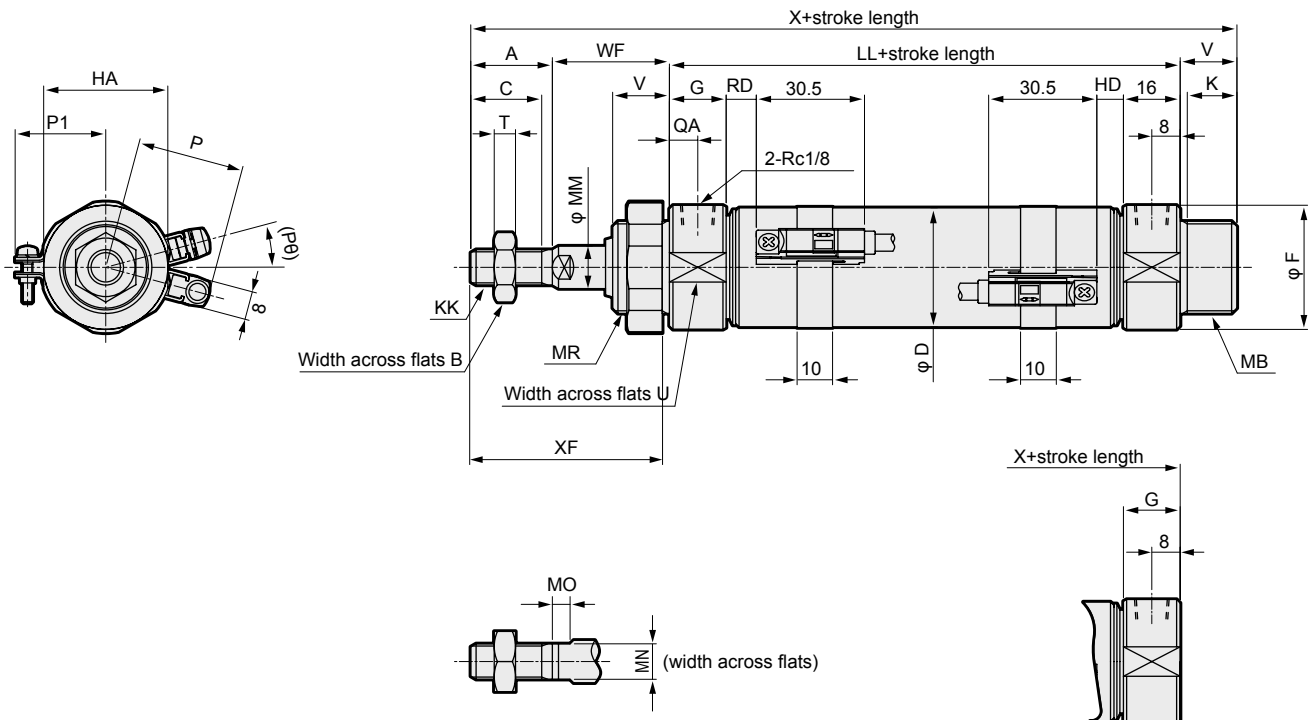

RD: rod end max. sensitivity position
 HD: head end max. sensitivity position

Code	Basic dimensions of basic type (OO)																
Bore size (mm)	A	B	C	D	F	G	QA	HA	K	KK	LL	MR	MB	MM	MN	MO	T
φ 20	20	13	18	21.4	30	16	8	35	14	M8 × 1.0	66	M26 × 1.5	M26 × 1.5	10	8	5	5
φ 25	23	17	20	26.4	32	16	8	35	14	M10 × 1.25	69	M26 × 1.5	M26 × 1.5	12	10	5	6
φ 32	23	17	20	33.6	36	16	8	35	14	M10 × 1.25	69	M26 × 1.5	M26 × 1.5	12	10	5	6
φ 40	25	19	22	41.6	45	16	8	38	14	M12 × 1.5	73	M30 × 1.5	M26 × 1.5	14	12	6	7

Code	With switch										Boss cut off form
Bore size (mm)	U	V	WF	X	XF	RD	HD	P	P1	(Pθ) °	X
φ 20	28	16	28	130	48	7	6	25.6	22	22	114
φ 25	30	16	28	136	51	8.5	7.5	25.6	22	18	120
φ 32	34	16	28	136	51	8.5	7.5	30.1	25.5	15	120
φ 40	43	16	28	142	53	10.5	9.5	34.1	29.5	12	126

CMK2-JG2/JG3 Series

Dimensions

● Axial foot type (LB)

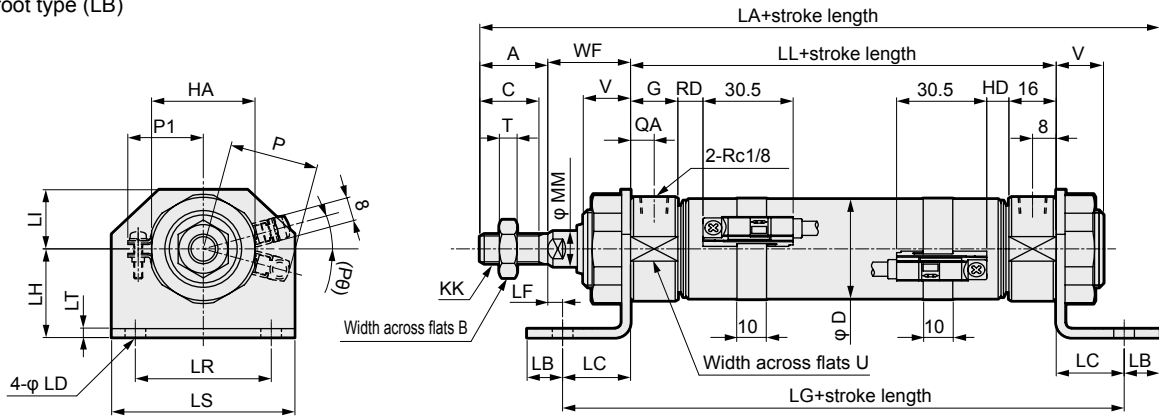

Code	Basic dimensions of axial foot type (LB)														Installation dimensions				
	A	B	C	D	G	QA	HA	KK	LL	MM	T	U	V	WF	LA	LB	LC	LD	LF
φ 20	20	13	18	21.4	16	8	35	M8 × 1.0	66	10	5	28	16	28	149	12	23	7	5
φ 25	23	17	20	26.4	16	8	35	M10 × 1.25	69	12	6	30	16	28	155	12	23	7	5
φ 32	23	17	20	33.6	16	8	35	M10 × 1.25	69	12	6	34	16	28	155	12	23	7	5
φ 40	25	19	22	41.6	16	8	38	M12 × 1.5	73	14	7	43	16	28	161	12	23	7	5

Code	With switch										
	Bore size (mm)	LG	LH	LI	LR	LS	LT	RD	HD	P	P1
φ 20	112	30	20	46	62	3	7	6	25.6	22	22
φ 25	115	30	20	46	62	3	8.5	7.5	25.6	22	18
φ 32	115	30	20	46	62	3	8.5	7.5	30.1	25.5	15
φ 40	119	30	20	46	62	3	10.5	9.5	34.1	29.5	12

● Single-sided axial foot type (LS)

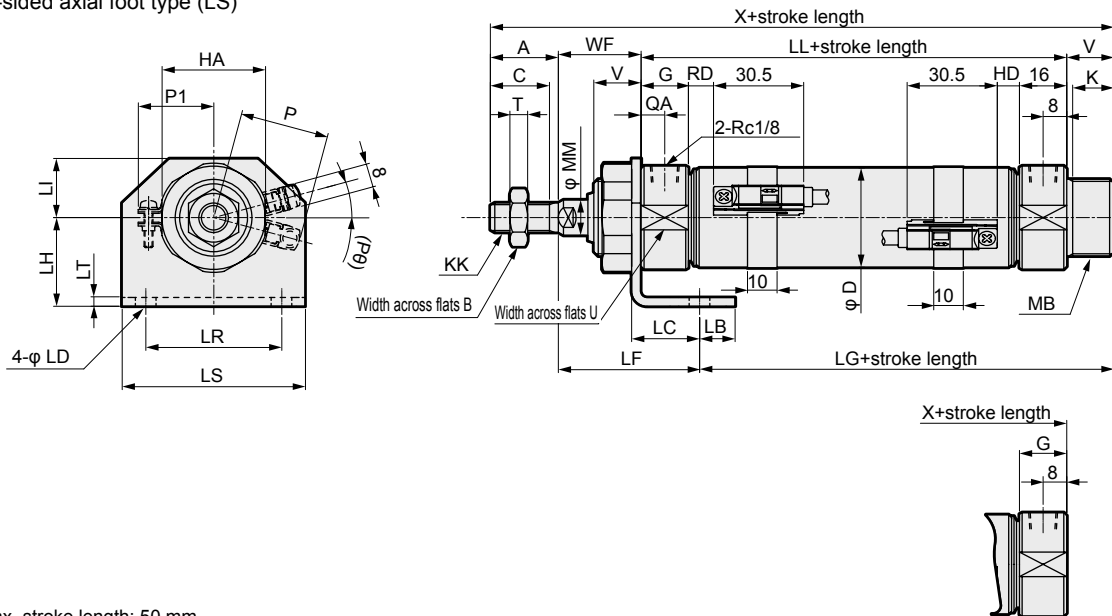

Note 1: Max. stroke length: 50 mm

Code	Basic dimensions of axial foot type (LS)																
	Bore size (mm)	A	B	C	D	G	QA	HA	K	KK	LL	MB	MM	T	U	V	WF
φ 20	20	13	18	21.4	16	8	35	14	M8 × 1.0	66	M26 × 1.5	10	5	28	16	28	130
φ 25	23	17	20	26.4	16	8	35	14	M10 × 1.25	69	M26 × 1.5	12	6	30	16	28	136
φ 32	23	17	20	33.6	16	8	35	14	M10 × 1.25	69	M26 × 1.5	12	6	34	16	28	136
φ 40	25	19	22	41.6	16	8	38	14	M12 × 1.5	73	M26 × 1.5	14	7	43	16	28	142

Code	Installation dimensions										With switch					Boss cut off form	
	Bore size (mm)	LB	LC	LD	LF	LG	LH	LI	LR	LS	LT	RD	HD	P	P1	(Pθ) °	X
φ 20	12	23	7	48	62	30	20	46	62	3	7	6	25.6	22	22	114	46
φ 25	12	23	7	48	65	30	20	46	62	3	8.5	7.5	25.6	22	18	120	49
φ 32	12	23	7	48	65	30	20	46	62	3	8.5	7.5	30.1	25.5	15	120	49
φ 40	12	23	7	48	69	30	20	46	62	3	10.5	9.5	34.1	29.5	12	126	53

Dimensions

● Rod end flange type (FA)

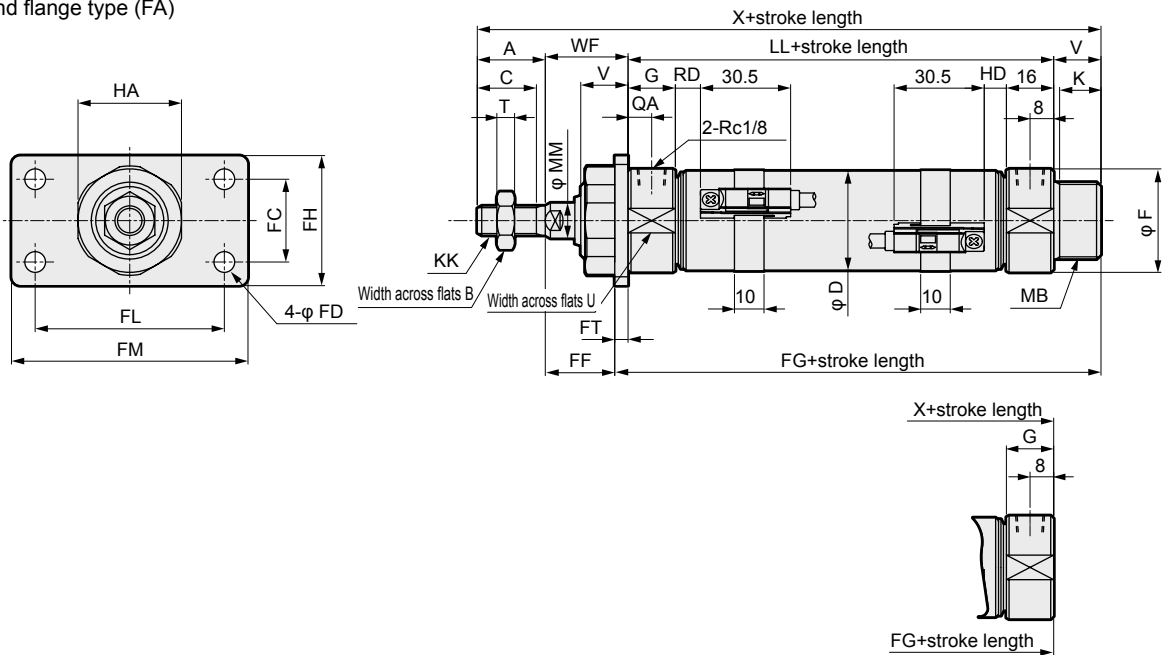

Code	Basic dimensions of rod end flange type (FA)																	
Bore size (mm)	A	B	C	D	F	G	QA	HA	K	KK	LL	MB	MM	T	U	V	WF	X
φ 20	20	13	18	21.4	30	16	8	35	14	M8 × 1.0	66	M26 × 1.5	10	5	28	16	28	130
φ 25	23	17	20	26.4	32	16	8	35	14	M10 × 1.25	69	M26 × 1.5	12	6	30	16	28	136
φ 32	23	17	20	33.6	36	16	8	35	14	M10 × 1.25	69	M26 × 1.5	12	6	34	16	28	136
φ 40	25	19	22	41.6	45	16	8	38	14	M12 × 1.5	73	M26 × 1.5	14	7	43	16	28	142

Code	Installation dimensions								With switch					Boss cut off form	
Bore size (mm)	FC	FD	FF	FG	FH	FL	FM	FT	RD	HD	P	P1	(Pθ) °	X	FG
φ 20	28	7	23	87	44	64	80	5	7	6	25.6	22	22	114	71
φ 25	28	7	23	90	44	64	80	5	8.5	7.5	25.6	22	18	120	74
φ 32	28	7	23	90	44	64	80	5	8.5	7.5	30.1	25.5	15	120	74
φ 40	28	7	23	94	44	64	80	5	10.5	9.5	34.1	29.5	12	126	78

● Head end flange type (FB)

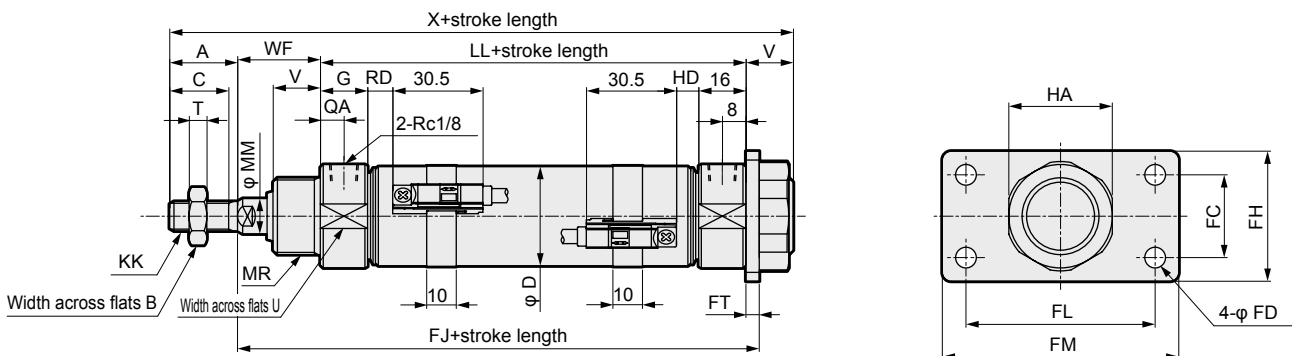

Code	Basic dimensions of head end flange type (FB)																
Bore size (mm)	A	B	C	D	G	QA	HA	K	KK	LL	MR	MM	T	U	V	WF	X
φ 20	20	13	18	21.4	16	8	35	14	M8 × 1.0	66	M26 × 1.5	10	5	28	16	28	130
φ 25	23	17	20	26.4	16	8	35	14	M10 × 1.25	69	M26 × 1.5	12	6	30	16	28	136
φ 32	23	17	20	33.6	16	8	35	14	M10 × 1.25	69	M26 × 1.5	12	6	34	16	28	136
φ 40	25	19	22	41.6	16	8	38	14	M12 × 1.5	73	M30 × 1.5	14	7	43	16	28	142

Code	Installation dimensions								With switch				
Bore size (mm)	FC	FD	FH	FJ	FL	FM	FT	RD	HD	P	P1	(Pθ) °	
φ 20	28	7	44	99	64	80	5	7	6	25.6	22	22	
φ 25	28	7	44	102	64	80	5	8.5	7.5	25.6	22	18	
φ 32	28	7	44	102	64	80	5	8.5	7.5	30.1	25.5	15	
φ 40	28	7	44	106	64	80	5	10.5	9.5	34.1	29.5	12	

CMK2-JG2/JG3 Series

Dimensions

● Integrated eye bracket type (CC)

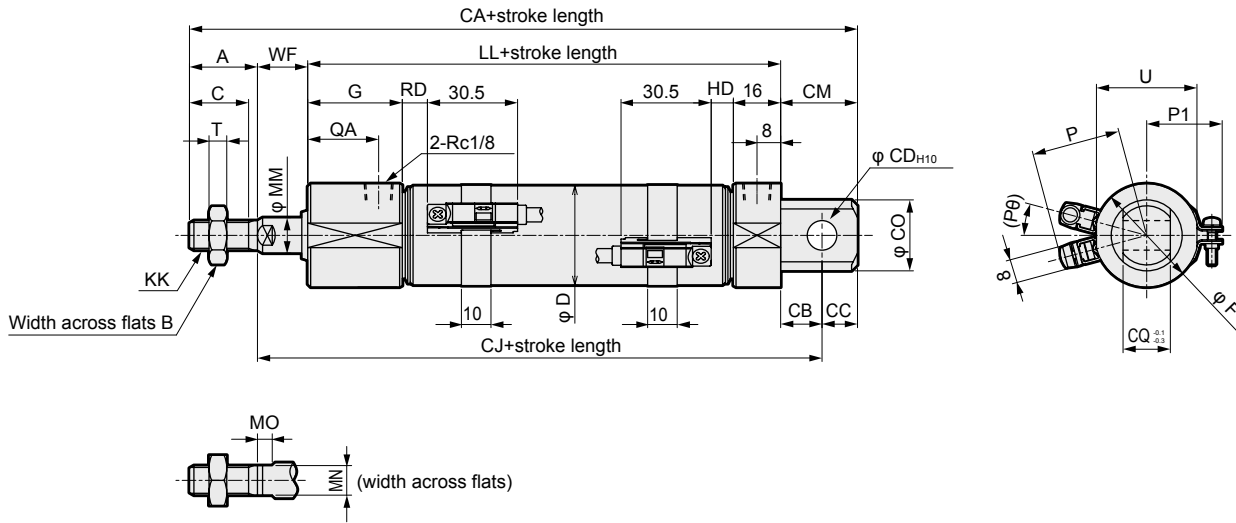

Code	Basic dimensions of integrated eye bracket type (CC)												Installation dimensions						
Bore size (mm)	A	B	C	D	F	G	QA	KK	LL	MM	T	U	WF	CA	CB	CC	CD	CJ	CM
φ 20	20	13	18	21.4	30	32	24	M8 × 1.0	82	10	5	28	12	135	12	9	8	106	21
φ 25	23	17	20	26.4	32	32	24	M10 × 1.25	85	12	6	30	12	141	12	9	8	109	21
φ 32	23	17	20	33.6	36	32	24	M10 × 1.25	85	12	6	34	12	146	14	12	10	111	26
φ 40	25	19	22	41.6	45	32	24	M12 × 1.5	89	14	7	43	12	156	16	14	12	117	30

Code	With switch						
Bore size (mm)	CO	CQ	RD	HD	P	P1	(Pθ) °
φ 20	22	16	7	6	25.6	22	22
φ 25	24	16	8.5	7.5	25.6	22	18
φ 32	24	16	8.5	7.5	30.1	25.5	15
φ 40	30	20	10.5	9.5	34.1	29.5	12

Accessory dimensions

● Rod eye (I)

Material: Stainless steel

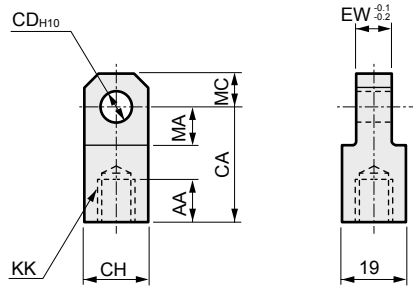

Model No.	Applicable bore size (mm)	AA	CA	CD	CH	EW	KK	MA	MC	Weight (g)
M1-I-20S	20	14	30	10	19	8	M8 × 1.0	13	10	60
M1-I-30S	25/32	14	36	12	25	10	M10 × 1.25	16	12	106
M1-I-40S	40	14	36	12	25	10	M12 × 1.5	16	12	100

● Rod clevis (Y)

Material: Stainless steel

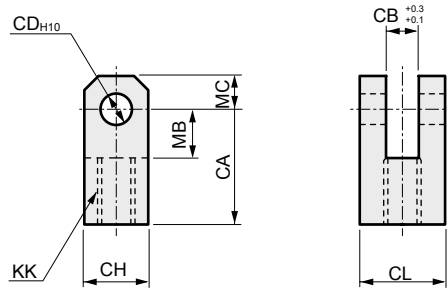

Model No.	Applicable bore size (mm)	CA	CB	CD	CH	CL	KK	MB	MC	Weight (g)
M1-Y-20S	20	30	8	10	19	19	M8 × 1.0	13	10	99
M1-Y-30S	25/32	36	10	12	25	25	M10 × 1.25	16	12	197
M1-Y-40S	40	36	10	12	25	25	M12 × 1.5	16	12	193

Note: A pin and split washer pin are attached to the product.

● Pin for rod clevis (P)

Material: Stainless steel

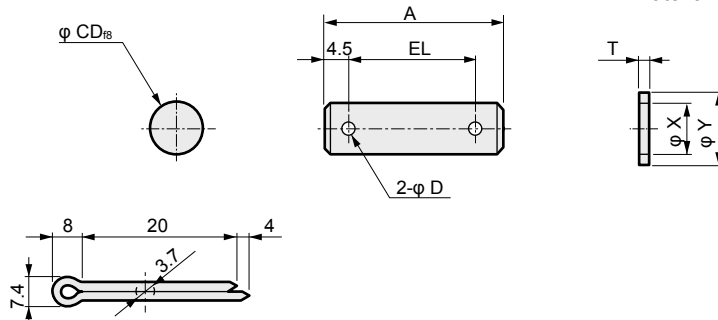

Model No.	Applicable bore size (mm)	A	D	CD	EL	T	X	Y	Weight (g)
M1-P-20S	20	37	4	10	28	1.6	10.5	18	29
M1-P-30S	25/32/40	46	4	12	37	2.3	12.5	22	50

Note: A pin and split washer pin for using the rod clevis are attached to the product.



Safety Precautions

Always read this section before use.

When designing and manufacturing a device using CKD products, the manufacturer is obligated to check that device safety mechanism, pneumatic control circuit, or water control circuit and the system operated by electrical control that controls the devices is secured.

It is important to select, use, handle and maintain the product appropriately to ensure that the CKD product is used safely.



Observe warnings and precautions to ensure device safety.

Check that device safety is ensured and a safe device is manufactured.

WARNING

- 1** This product is designed and manufactured as a general industrial machine part.
It must be handled by an operator having sufficient knowledge and experience in handling.
- 2** Use this product in accordance with specifications.
This product must be used within its stated specifications. You should never modify or machine them.
This product is intended for use as a device or part for general-purpose industrial machinery. It is not intended for use outdoors (except for outdoor type) or for use under the following conditions or environment.
(Note that this product can be used when CKD is consulted prior to use and the customer consents to CKD product specifications. The customer must provide safety measures to avoid risks in the event of problems.)
 - ①** Use for special applications including nuclear energy, railways, aircrafts, marine vessels, vehicles, medicinal devices, devices or applications coming into contact with beverages or food, amusement devices, emergency cutoff circuits, press machines, brake circuits, or safety devices or applications.
 - ②** Use for applications where life or assets could be significantly affected, and special safety measures are required.
- 3** Observe body standards and regulations, etc., related to the safety of device design and control, etc.
ISO4414, JIS B 8370 (General rules for pneumatic systems)
JFPS2008 (Principles for pneumatic cylinder selection and use)
Including High Pressure Gas Safety Act, Industrial Safety and Health Act, other safety rules, body standards and regulations, etc.
- 4** Do not handle, pipe, or remove devices before confirming safety.
 - ①** Inspect and service the machine and devices after confirming safety of the entire system related to this product.
 - ②** Note that there may be hot or charged sections even after operation is stopped.
 - ③** When inspecting or servicing the device, turn off the energy source (air supply or water supply), and turn off power to the facility. Release any compressed air from the system, and pay enough attention to possible water leakage and leakage of electricity.
 - ④** When starting or restarting the machinery and equipment using pneumatic components, make sure that the system safety, such as pop-out prevention measures, is secured.
- 5** Observe warnings and cautions on the pages below to prevent accidents.

■ The precautions are ranked as "DANGER", "WARNING" and "CAUTION" in this section.

-  **DANGER:** When a dangerous situation may occur if handling is mistaken leading to fatal or serious injuries, and when there is a high degree of emergency to a warning.
-  **WARNING:** When a dangerous situation may occur if handling is mistaken leading to fatal or serious injuries.
-  **CAUTION:** When a dangerous situation may occur if handling is mistaken leading to minor injuries or physical damage.

Note that some items described as "CAUTION" may lead to serious results depending on the situation.
Every item provides important information and must be observed.

Limited warranty and disclaimer

- 1** Term of warranty
This warranty shall be valid for one year after delivery to the customer's designated site.
- 2** Scope of warranty
If any faults, found to be the responsibility of CKD, occur during the above warranty term, the product shall be replaced, the required replacement parts provided free of charge, or shall be repaired at the CKD factory free of charge.
Note that the following faults are excluded from the warranty scope:
 - (1) Failure due to use exceeding the conditions and environments set forth in the catalog or these specifications.
 - (2) Failure resulting from factors other than this product.
 - (3) Faults caused by improper use of the product.
 - (4) Faults resulting from modifications or repairs made without CKD consent.
 - (5) Faults caused by matters that could not be predicted with the technologies applied when the product was delivered.
 - (6) Faults resulting from natural disasters or accidents for which CKD is not liable.The warranty covers the actually delivered product, and does not cover any damage resulting from losses induced by faults in the delivered product.
- 3** Compatibility confirmation
The customer is responsible for confirming the compatibility of CKD products with the customer's systems, machines and equipment.



For general information on the Pneumatic component

Safety Precautions

Always read this section before use.

cylinders and cylinder switches, refer to "Pneumatic Cylinders I (No.CB-029SA)".

Individual precautions: Medium bore size cylinder CMK2-JG2/JG3 Series

Design & selection

CAUTION

- Use products at your own discretion upon careful confirmation of the construction materials (only the external body is made of stainless steel), valve structure, working fluid and compatible atmospheres.
- A minute amount of mineral oil is contained within the bearings used with the cylinder. Although the product has been treated to prevent discharge of the mineral oil during use within the scope of the product specifications, please take into consideration the risk of discharge when deciding on the installation location.

- Do not apply an eccentric load to the piston rod. Doing so may shorten the service life of the scraper and/or bearing.
- Mount the speed controller on the cylinder.
 - Mount the speed controller on the cylinder. Use each cylinder within the applicable working piston speed range.
- In the case where there is no water spattering, be careful in that the lubrication of the piston rod will run out and shorten the service life.

Installation & adjustment

CAUTION

- Do not turn the cover.
 - If the cover is turned when mounting the cylinder or screwing the pipe fitting into the port, the breakage from the cover connection could occur.

- Be sure to apply grease when using the pin to prevent seizing.

During use & maintenance

CAUTION

- When moving the switch position in the stroke length direction
 - When fine-tuning the position of the switch, move the band position.
 - Loosen the switch fixing screw, shift the switch along the rail, then tighten at the specified position. Fix the product in place with a tightening torque of 0.5 to 0.7 N·m.
- When moving the switch position in the circumferential direction
 - Loosen the band fixing screw, shift the switch rail in the circumference direction, then tighten at the specified position. The appropriate tightening torque is 0.6 to 0.8 N·m.
- It is recommended that a minimal amount of cleaning be conducted on the sliding portion and grease be applied after cleaning. Note that if water is only splattered temporarily, grease should be applied regularly. Contact CKD for maintenance grease.

Shifting the band position

- Loosen the band fixing screw, shift the switch rail and band along the cylinder tube, and tighten at the specified position. The appropriate tightening torque is 0.6 to 0.8 N·m.

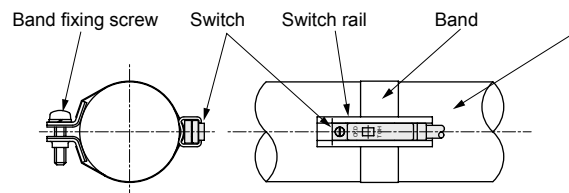

- After installing, check for leaks from pipes and for wire connections, and check that the product is correctly installed.
- Do not use products as footing or place any heavy objects on top of the products.
- If the product has not been in use for over one month, perform a test run before starting actual operation.

Related products

FP Series products for foodstuff manufacturing processes

- A broad lineup ranging from air filters to actuators that can safely be used for foodstuff manufacturing processes.
- In order to eliminate worries of contamination due to lubricants, the FP1 Series uses a food-grade (NSF H1) lubricant
- In addition to FP1, the FP2 Series uses resin and rubber materials compliant with the Food Sanitation Act

Catalog No. CC-1271A

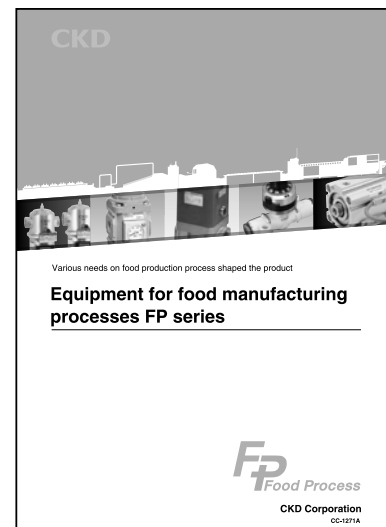

FP1

Avoid contamination from lubricants. Food grade lubricant (NSF H1) is used.

Pencil shaped cylinder
SCPD3 Series



Medium bore size cylinder
CMK2 Series



Round shaped cylinder
SCM Series



Tie rod cylinder
SCG Series



T-switch equipped medium bore size cylinder
SCA2 Series



Medium bore size cylinder
SCS2 Series



Compact cylinder
SSD2 Series



Guided cylinder
STG-M Series



Rodless cylinder
SRL3 Series



Feather hand (mini-parallel hand)
FH100 Series



Compact cross roller parallel hand
BHA Series



Compact wide parallel hand
HMF Series

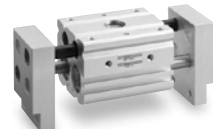

Feather hand (mini-fulcrum hand)
FH500 Series



Air operated type 2-port valve
SAB Series



Filters/regulators
W1*00 to 8*00 Series



Air filter
F1000 to 8000 Series



Oil mist filter
M(X)1000 to 8000 Series



Regulator
R1*00 to 8*00 Series



Reed switch type compact mechanical pressure switch
P1100 to 8100 Series



Shut-off valve
V1000/V3000/V3010/V6010 Series



CMK2-JG2/JG3 Series

Related products

Super dryer
SU/SD Series



Medium main line filter
AF Series



Fitting
GW Series



Fitting (stainless steel series)
ZW Series



Elbow type speed controller with push-in fitting
SC3W Series



Speed controller with dial
DSC Series



Speed controller line type with push-in fitting
SCL2 Series



Needle valve with dial
DVL-S Series



Speed controller
SC-M5 Series



Speed controller
SC1 Series



Metering valve with silencer
SMW/SMW2 Series



Block valve
FPV Series



Quick exhaust valve
2QV/3QV Series



FP2

Material compatible with Food Sanitation Law is used.

2-port direct acting solenoid valve, general purpose valve
AB31/41 Series



3-port direct acting solenoid general purpose valve
AG31/41/33/43/34/44 Series



2-port pilot operated solenoid general purpose valve for dry air
ADK11-Z Series



Diaphragm cylinder valve
LAD Series



Diaphragm cylinder valve
NAD Series



Diaphragm cylinder valve manifold
GNAD Series

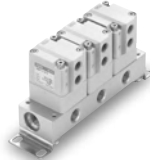

Compact rotary valve
CHB/CHG Series



Metal-free solenoid valve
MYB3 Series



High corrosion resistant 2-port direct acting solenoid valve
HB Series



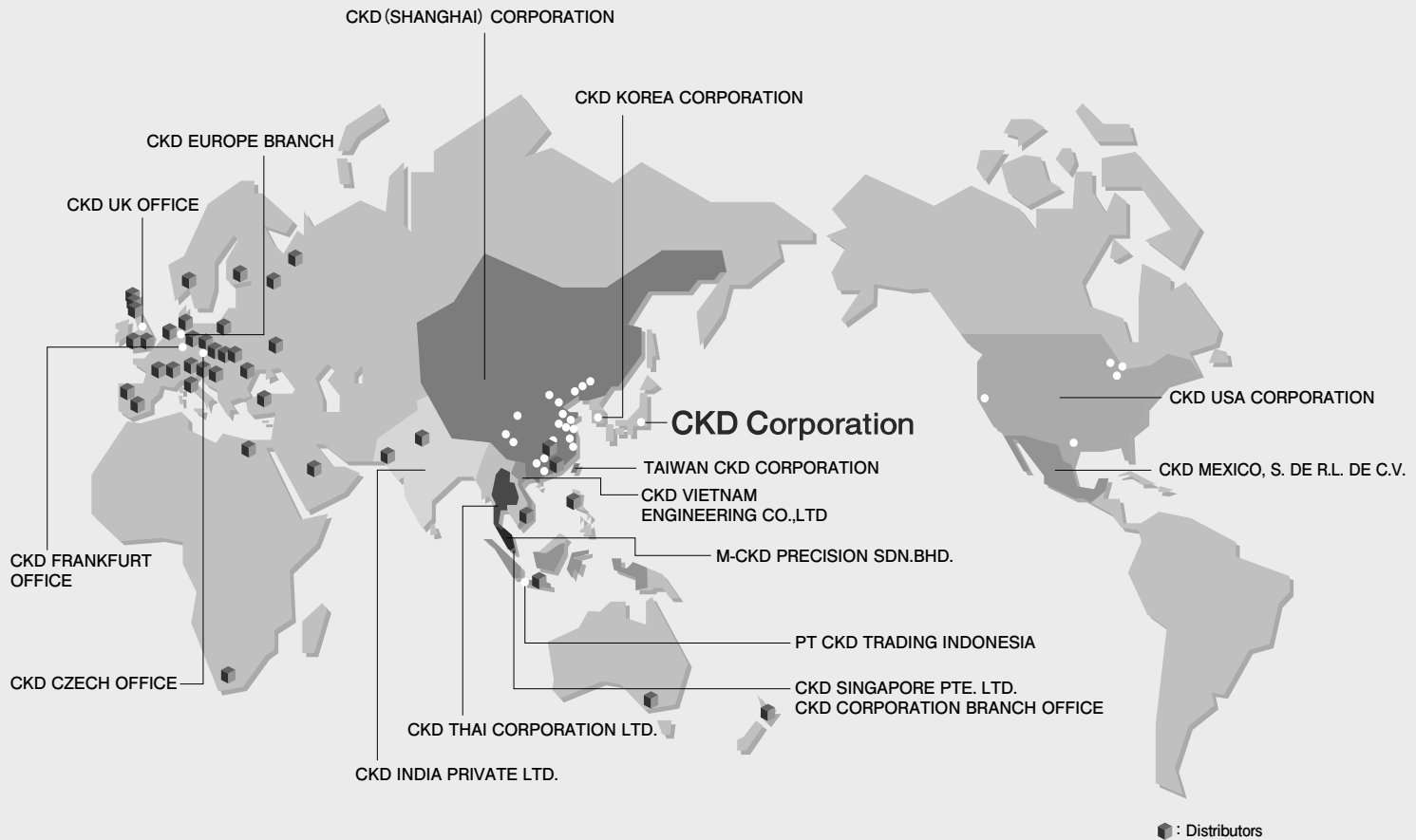

CKD Corporation

□ 2-250 O uji Komaki, Aichi 485-8551, Japan
 □ PHONE +81-(0)568-74-1338 FAX +81-(0)568-77-3461

U.S.A.

CKD USA CORPORATION
●CHICAGO HEADQUARTERS
 4080 Winnetka Avenue, Rolling Meadows, IL 60008, USA
 PHONE +1-847-368-0539 FAX +1-847-788-0575
 • CINCINNATI OFFICE
 • SAN ANTONIO OFFICE
 • SAN JOSE OFFICE
 • DETROIT OFFICE

Mexico

CKD MEXICO, S. DE R.L. DE C.V.
 Cerrada la Noria No. 200 Int. A-01, Querétaro Park II,
 Parque Industrial Querétaro, Santa Rosa Jáuregui,
 Querétaro, C.P. 76220, México
 PHONE +52-442-161-0624

Europe

CKD CORPORATION EUROPE BRANCH
 De Fruittuinen 28 Hoofddorp, the Netherlands
 PHONE +31-(0)23-5541490 FAX +31-(0)23-5541491
 • CZECH OFFICE
 • UK OFFICE
 • FRANKFURT OFFICE

Malaysia

M-CKD PRECISION SDN.BHD.
●HEAD OFFICE
 Lot No.6, Jalan Modal 23/2, Seksyen 23, Kawasan MIEL,
 Fasa 8, 40300 Shah Alam, Selangor Darul Ehsan, Malaysia
 PHONE +60-(0)3-5541-1468 FAX +60-(0)3-5541-1533
 • JOHOR BAHRU BRANCH OFFICE
 • PENANG BRANCH OFFICE

Thailand

CKD THAI CORPORATION LTD.
●SALES HEADQUARTERS
 Suwan Tower, 14/1 Soi Saladaeng 1, North Sathorn Road,
 Kwaeng Silom, Khet Bangrak, Bangkok 10500, Thailand
 PHONE +66-(0)2-267-6300 FAX +66-(0)2-267-6305
 • RAYONG OFFICE
 • NAVANAKORN OFFICE
 • EASTERN SEABOARD OFFICE
 • LAMPHUN OFFICE
 • KORAT OFFICE
 • AMATANAKORN OFFICE
 • PRACHINBURI OFFICE
 • SARABURI OFFICE

Singapore

CKD SINGAPORE PTE. LTD.
 No.33 Tannery Lane #04-01 Hoesteel Industrial
 Building, Singapore 347789, Singapore
 PHONE +65-67442623 FAX +65-67442486
CKD CORPORATION BRANCH OFFICE
 No.33 Tannery Lane #04-01 Hoesteel Industrial
 Building, Singapore 347789, Singapore
 PHONE +65-67447260 FAX +65-68421022
 • INDIA LIAISON OFFICE BANGALORE
 • INDIA LIAISON OFFICE DELHI

India

CKD INDIA PRIVATE LTD.
 Unit No. 607, 6th Floor, WellDone Tech Park, Sector 48,
 Sohna Road, Gurgaon-122018, Haryana, India
 PHONE +91-(0)124-418-8212

Indonesia

PT CKD TRADING INDONESIA
 Wisma Keiai, 17th Floor, Jl. Jendral
 Sudirman Kav.3, Jakarta 10220, Indonesia
 PHONE +62-(0)21-572-3220 FAX +62-(0)21-573-4112

Vietnam

CKD VIETNAM ENGINEERING CO.,LTD.
 18th Floor, CMC Tower, Duy Tan Street, Cau Giay
 District, Hanoi, Vietnam
 PHONE +84-4-37957631 FAX +84-4-37957637

Taiwan

台灣喜開理股份有限公司
TAIWAN CKD CORPORATION
 16F-3, No. 7, Sec. 3, New Taipei Blvd., Xinzhuang Dist.,
 New Taipei City 242, Taiwan
 PHONE +886-(0)2-8522-8198 FAX +886-(0)2-8522-8128
 • 新竹營業所 (HSINCHU OFFICE)
 • 台中營業所 (TAICHUNG OFFICE)
 • 台南營業所 (TAINAN OFFICE)

China

喜開理(上海)機器有限公司
CKD(SHANGHAI)CORPORATION
●營業部 / 上海浦西事務所 (SALES HEADQUARTERS / SHANGHAI PUXI OFFICE)
 Room 601, 6th Floor, Yuanzhongkeyan Building, No. 1905
 Hongmei Road, Xinhui District, Shanghai 200233, China
 PHONE +86-(0)21-61911888 FAX +86-(0)21-60905356
 • 上海浦東事務所 (SHANGHAI PUDONG OFFICE)
 • 無錫事務所 (WUXI OFFICE)
 • 杭州事務所 (HANGZHOU OFFICE)
 • 寧波事務所 (NINGBO OFFICE)
 • 南京事務所 (NANJING OFFICE)
 • 蘇州事務所 (SUZHOU OFFICE)
 • 昆山事務所 (KUNSHAN OFFICE)
 • 北京事務所 (BEIJING OFFICE)
 • 天津事務所 (TIANJIN OFFICE)
 • 長春事務所 (CHANGCHUN OFFICE)
 • 大連事務所 (DALIAN OFFICE)
 • 青島事務所 (QINGDAO OFFICE)
 • 濟南事務所 (JINAN OFFICE)
 • 煙台事務所 (YANTAI OFFICE)
 • 瀋陽事務所 (SHENYANG OFFICE)
 • 重慶事務所 (CHONGQING OFFICE)
 • 成都事務所 (CHENGDU OFFICE)
 • 西安事務所 (XIAN OFFICE)
 • 武漢事務所 (WUHAN OFFICE)
 • 鄭州事務所 (ZHENGZHOU OFFICE)
 • 長沙事務所 (CHANGSHA OFFICE)
 • 廣州事務所 (GUANGZHOU OFFICE)
 • 深圳西事務所 (WEST SHENZHEN OFFICE)
 • 深圳東事務所 (EAST SHENZHEN OFFICE)
 • 東莞事務所 (DONGGUAN OFFICE)
 • 廈門事務所 (XIAMEN OFFICE)

Korea

CKD KOREA CORPORATION
●HEADQUARTERS
 (3rd Floor), 44, Sinsu-ro, Mapo-gu, Seoul 121-856, Korea
 PHONE +82-(0)2-783-5201~5203 FAX +82-(0)2-783-5204
 • 水原營業所 (SUWON OFFICE)
 • 天安營業所 (CHEONAN OFFICE)
 • 蔚山營業所 (ULSAN OFFICE)

The goods and/or their replicas, or the technology and/or software found in this catalog are subject to complementary export regulations by Foreign Exchange and Foreign Trade Law of Japan. If the goods and/or their replicas, the technology and/or software found in this catalog are to be exported, law requires that the exporter makes sure that they will never be used for the development or manufacture of weapons for mass destruction.