

# 4F

## 5 port pilot operated valve

## Pneumatic valve

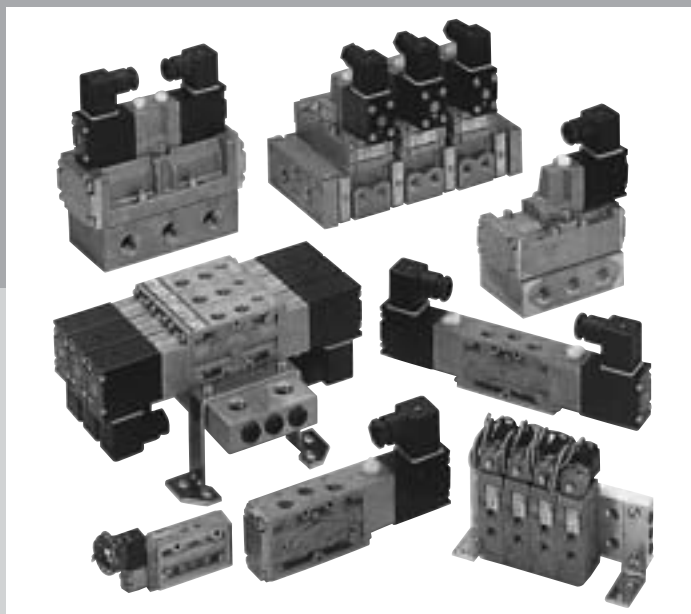

### CONTENTS

Series variation	884
Variation of electric connection (method / circuit diagram)	886
<b>⚠ Safety precautions</b>	888
<b>Discrete valve</b>	
● Body porting (4F0/1/2/3)	890
● Sub-plate porting (4F4/5/6/7)	904
<b>Individual wiring manifold</b>	
● Body porting ((A) M4F0/1/2/3)	918
● Sub-plate porting (M4F4/5/6/7)	946
<b>Technical data</b>	
(1) How to wire gland and connector	972
4F Series common check valve / terminal box / optional dimensions	954
Manifold specification sheet	956

MN3E0  
MN4E0

4GA/B

M4GA/B

MN4GA/B

4GA/B  
(Master)

W4GA/B2

W4GB4

MN3S0  
MN4S0

4TB

4L2-4/  
LMF0

4SA/B0

4SA/B1

4KA/B

**4F**

PV5G/  
CMF

PV5/  
CMF

3MA/B0

3PA/B

P/M/B

NP/NAP/  
NVP

4F\*0E

HMV  
HSV

2QV  
3QV









SKH

PCD/  
FS/FD

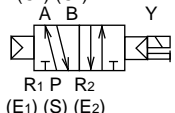
Ending

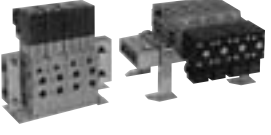
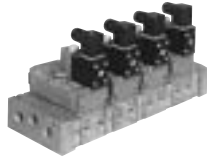
5 port pilot operated valve

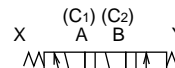
MN3E0
MN4E0
4GA/B
M4GA/B
MN4GA/B
4GA/B (Master)
W4GA/B2
W4GB4
MN3S0
MN4S0
4TB
4L2-4/LMFO
4SA/B0
4SA/B1
4KA/B
<b>4F</b>
PV5G/CMF
PV5/CMF
3MA/B0
3PA/B
P/M/B
NP/NAP/NVP
4F*0E
HMV/HSV
2QV/3QV
SKH
PCD/FS/FD
Ending

Piping method / appearance	Model no.	Position No. of solenoid JIS symbol	Flow characteristics		Applicable bore size	Voltage (V)			
			C (dm <sup>3</sup> /(s·bar)) Note 1	Effective sectional area S (mm <sup>2</sup> )					
<b>4F</b>  	Body porting	(A) 4F0 * A is single.	<b>4F0 to 4F7</b> ● 2-position single solenoid (C <sub>1</sub> ) (C <sub>2</sub> )  R <sub>1</sub> P R <sub>2</sub> (E <sub>1</sub> ) (S) (E <sub>2</sub> )	0.6 to 0.7	-	ø16 to ø20	100 AC 200 AC 24 DC Option 110 AC 220 AC 12 DC		
		4F1		1.5 to 2.0	-	ø20 to ø25			
		4F2		2.5 to 3.0	-	ø40 to ø80			
		4F3		3.9 to 5.8	-	ø63 to ø100			
		Sub-plate porting		4F4	● 2-position double solenoid (C <sub>1</sub> ) (C <sub>2</sub> ) X A B Y  R <sub>1</sub> P R <sub>2</sub> (E <sub>1</sub> ) (S) (E <sub>2</sub> )	5.0 to 5.3		-	ø63 to ø100
				4F5	9.7 to 10	-		ø80 to ø160	
				4F6	<b>4F1 to 4F7</b> ● 3-position all ports closed	15 to 18		-	ø140 to ø200
	4F7		-	160	ø180 to ø250				
	<b>M4F</b>  	Body porting	(A) M4F0 * A is single.	(C <sub>1</sub> ) (C <sub>2</sub> ) X A B Y  R <sub>1</sub> P R <sub>2</sub> (E <sub>1</sub> ) (S) (E <sub>2</sub> )	0.6 to 0.7	-	ø16 to ø20	100 AC 200 AC 24 DC Option 110 AC 220 AC 12 DC	
			M4F1		1.5 to 2.0	-	ø20 to ø25		
			M4F2		● 3-position A/B/R (C <sub>1</sub> ) (C <sub>2</sub> ) X A B Y  R <sub>1</sub> P R <sub>2</sub> (E <sub>1</sub> ) (S) (E <sub>2</sub> )	2.5 to 3.0	-		ø40 to ø80
			M4F3		3.9 to 5.8	-	ø63 to ø100		
			Sub-plate porting		M4F4	5.0 to 5.3	-		ø63 to ø100
					M4F5	● 3-position P/A/B (C <sub>1</sub> ) (C <sub>2</sub> ) X A B Y  R <sub>1</sub> P R <sub>2</sub> (E <sub>1</sub> ) (S) (E <sub>2</sub> )	9.7 to 10		-
M4F6					15 to 18	-	ø140 to ø200		
M4F7		-		160	ø180 to ø250				

Note 1: Effective sectional area S and sonic conductance C are converted as  $S \approx 5.0 \times C$ .

	Solenoid position						A/B port size								Electric connection						Page		
	2-position single solenoid	2-position double solenoid	3-position all ports closed	3-position A/B/R connection	3-position P/A/B connection	Mix	Female thread								Small terminal box	DIN terminal box	C-connector	D-connector	Grommet lead wire	Conduit lead wire		Round terminal box	
							M5	Rp1/8	Rp1/4	Rp3/8	Rc1/4	Rc3/8	Rc1/2	Rc3/4									Rc1
	●	●					●	●							●		●	●	●				890
	●	●	●	●				●	●						●		●	●	●				
	●	●	●	●					●						●			●	●	●			
	●	●	●	●	●				●	●					●			●	●	●			
	●	●	●	●	●										●			●	●	●			904
	●	●	●	●	●										●			●	●	●			
	●	●	●	●	●										●			●	●	●			
	●	●	●	●	●	●	●	●							●		●	●	●				
	●	●	●	●	●	●	●	●							●		●	●	●				918
	●	●	●	●	●	●		●	●						●		●	●	●				
	●	●	●	●	●	●			●	●					●			●	●	●			
	●	●	●	●	●	●				●	●				●			●	●	●			
	●	●	●	●	●	●									●			●	●	●			946
	●	●	●	●	●	●									●			●	●	●			
	●	●	●	●	●	●									●			●	●	●			
	●	●	●	●	●	●									●			●	●	●			

\* Refer to the following page for details on electric connection and other options.

MN3E0  
MN4E0

4GA/B

M4GA/B

MN4GA/B

4GA/B  
(Master)

W4GA/B2

W4GB4

MN3S0  
MN4S0

4TB

4L2-4/  
LMF0

4SA/B0

4SA/B1

4KA/B

**4F**

PV5G/  
CMF

PV5/  
CMF

3MA/B0

3PA/B

P/M/B

NP/NAP/  
NVP

4F\*0E

HMV  
HSV

2QV  
3QV

SKH

PCD/  
FS/FD





Ending

5 port pilot operated valve

# 4F Series

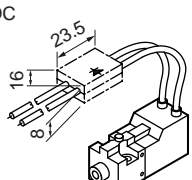
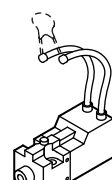
	Electric connection				Manual override	
MN3E0 MN4E0	<b>4F0/4F1</b>					
4GA/B	<b>Blank</b> <b>B</b> Small terminal box	<b>C</b> C-connector with lead wire	<b>C3</b> C-connector without lead wire with surge suppressor, light	<b>D2</b> D-connector with lead wire, surge suppressor, light	<b>Blank</b> Lateral non-locking type	<b>M6</b> Upward non-locking type
MN4GA/B		● Lead wire length C : 300 mm C00: 500 mm C01: 1000 mm C02: 2000 mm C03: 3000 mm		● Lead wire length D2 : 300 mm D20: 500 mm D21: 1000 mm D22: 2000 mm D23: 3000 mm		
4GA/B (Master)	90°	180°	180°	180°	Press with a rod less than ø3	Press with a rod less than ø2
W4GA/B2						
W4GB4						
MN3S0 MN4S0	<b>Blank</b> <b>E</b> Grommet lead wire	<b>C1</b> C-connector without lead wire	<b>D</b> D-connector with lead wire	<b>D3</b> D-connector without lead wire with surge suppressor, light	<b>M1</b> Lateral locking type	<b>R</b> Manual override position change
4TB			● Lead wire length D : 300 mm D00: 500 mm D01: 1000 mm D02: 2000 mm D03: 3000 mm		Rotate 90° with minus screw driver	
4L2-4/LMFO						S port Manual override
4SA/B0		180°	180°	180°	ON OFF	
4SA/B1						
4KA/B						
<b>4F</b>	<b>L</b> <b>L2</b> Small terminal box with light	<b>C2</b> C-connector with lead wire, surge suppressor, light	<b>D1</b> D-connector without lead wire		<b>M4</b> Non-locking with dust cover	
PV5G/CMF	With lead wire (only L2)	● Lead wire length C2 : 300 mm C20: 500 mm C21: 1000 mm C22: 2000 mm C23: 3000 mm				
3MA/B0	90°	180°	180°		Press by hand.	
3PA/B						
P/M/B						
NP/NAP/ NVP						
4F*0E	<b>4F2 to 4F7</b>					
HMV HSV	<b>Blank</b> DIN terminal box	<b>F</b> DIN terminal box (G1/2)	<b>E1</b> Conduit lead wire (CTC19)	<b>B</b> <b>B1</b> Round terminal box	<b>Blank</b> Locking	<b>M3</b> Locking with manual lever
2QV 3QV				B : G1/2 B1: G3/4		The lever is mounted on a manual knob to enhance operability.
SKH	90° Pg11	G1/2	CTC19			Manual lever
PCD/ FS/FD						
Ending						
	<b>L</b> DIN terminal box with indicator light	<b>E</b> Grommet lead wire	<b>E2</b> Conduit lead wire (G1/2)	<b>BL</b> Round terminal box (G1/2) with indicator light	<b>M2</b> Non-locking	<b>R</b> Manual override position change
					Push with ø7 or smaller rod. Manual override	
	Pg11		G1/2		Dust cover is custom order.	

### Electric connection circuit diagram

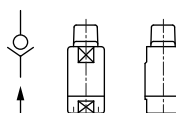
Other options	
<b>S</b>	Surge suppressor attached
DC	 <p>24 VDC or less Only lead wire type (Diode type)</p>
AC/DC	 <p>For other than DC lead wire type and AC.</p>
<b>N</b>	Plug attached
	 <p>N.C./C: A, E: Assembled to R<sub>1</sub> N.O./C: A, E: Assembled to R<sub>2</sub></p>
<b>S</b>	Surge suppressor attached
	
<b>N</b>	Plug attached
	 <p>N.C./C: A, E: Assembled to R<sub>1</sub> N.O./C: B, E: Assembled to R<sub>2</sub></p>
<b>H</b>	Check valve attached
	

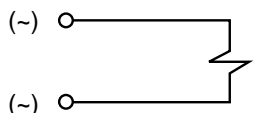
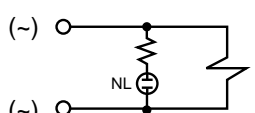
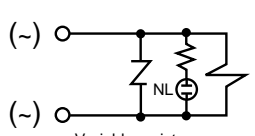
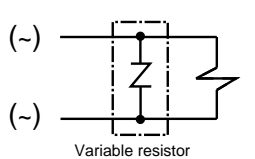
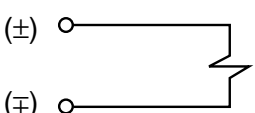
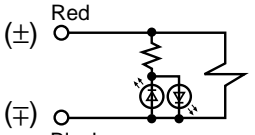
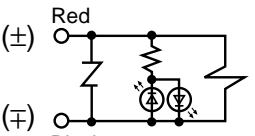
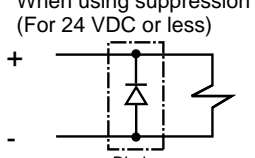
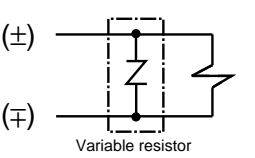
Voltage type	Option	Electric wire circuit diagram	Electric connection	
AC	--		Grommet lead wire Terminal box (B/F) C-connector (C/C0*/C1) D-connector (D/D0*/D1)	
	With indicator light		Terminal box (L/L2)	
	Surge suppressor with indicator light	 <p>Variable resistor</p>	Terminal box (LS) C-connector (C2/C2*/C3) D-connector (D2/D2*/D3)	
	Surge suppressor attached	 <p>Variable resistor</p>	Surge suppressor attached (S)	
DC	--		Grommet lead wire Terminal box (B/F) C-connector (C/C0*/C1) D-connector (D/D0*/D1)	
	With indicator light	 <p>Red Black</p>	Terminal box (L/L2)	
	Surge suppressor with indicator light	 <p>Red Black Variable resistor</p>	Terminal box (LS) C-connector (C2/C2*/C3) D-connector (D2/D2*/D3)	
	Surge suppressor attached	When using suppression (For 24 VDC or less)	 <p>Diode * A diode has polarity.</p>	Grommet lead wire (Option symbol "S" indicates) a surge suppressor.
			 <p>Variable resistor * The varistor has no polarity.</p>	Surge suppressor attached (S)

MN3E0  
MN4E0

4GA/B

M4GA/B

MN4GA/B

4GA/B  
(Master)

W4GA/B2

W4GB4

MN3S0  
MN4S0

4TB

4L2-4/  
LMF0

4SA/B0

4SA/B1

4KA/B

**4F**PV5G/  
CMFPV5/  
CMF

3MA/B0

3PA/B

P/M/B

NP/NAP/  
NVP

4F\*0E

HNV  
HSV2QV  
3QV

SKH

PCD/  
FS/FD

Ending

5 port pilot operated valve



Pneumatic components

# Safety precautions

Always read this section before starting use.  
Refer to Intro 63 for valve general precautions.

MN3E0  
MN4E0

4GA/B

M4GA/B

MN4GA/B

4GA/B  
(Master)

W4GA/B2

W4GB4

MN3S0  
MN4S0

4TB

4L2-4/  
LMFO

4SA/B0

4SA/B1

4KA/B

4F

PV5G/  
CMF

PV5/  
CMF

3MA/B0

3PA/B

P/M/B

NP/NAP/  
NVP

4F\*0E

HMV  
HSV

2QV  
3QV

SKH

PCD/  
FS/FD

Ending

## 5 port pilot operated valve 4F Series

### During Use & Maintenance

#### 1. Common

##### CAUTION

- Do not plug in the PE port.  
The pilot pressure will not be exhausted, inhibiting valve operation.
- When using the DIN terminal box with continuous power ON specifications where the ambient temperature is high, the gasket could deteriorate quickly. Replace the gasket in this case.
- The external pilot is low pressure specification for pressurizing the P (S) port. Contact CKD when using a vacuum or pressurizing from another port.
- Use the manual button to confirm trial operation. If this button is left locked for a long time, the locking mechanism could be damaged, and the state may change from ON to OFF.
- Stations  
When operating 6 or more valves at once, supply pressure (S) from both ends of the manifold block, and release the exhaust (E) to the air from both ends. Failure to use both ends will cause malfunctions due to exhaust pressure.
- The connection port for the 4F0 to 4F3 series has Rp parallel threads. Wrap sealing tape or apply adhesive before connecting pipes to prevent leakage when pipes are connected.

#### 2. Manual override

##### CAUTION

- Manual override  
This solenoid valve is pilot-operated, so even if manual override operates, the main valve does not change unless air is supplied to the S port.
- Non-locking manual override  
With non-locking manual override, press manual override with a rod. When using the 2-position single solenoid or 3-position solenoid, the valve is in the same status as when power is on while override is pressed down. Status is returned when released. With the 2-position double solenoid, the same state as when X (Y) is energized is set when X (Y) manual override is pressed. The main valve holds this status even when manual override is released. Operate Y (X) side manual override to restore status.

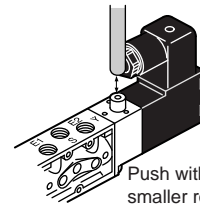

Push with  $\varnothing 7$  or smaller rod.

(When using 4F0/1, push with  $\varnothing 3$  or smaller rod.)

##### Locking manual override

- Rotating locking manual override 45° with a screwdriver sets the valve to the same status as when energized and locks it. Override is turned only clockwise. Do not rotate beyond locked status or the mechanism could be damaged. Locked manual override must be unlocked (position 0) before normal operation is started.







# Discrete valve / body porting

## 5 port pilot operated pneumatic valve

# 4F0/1/2/3 Series

● Applicable cylinder bore size:  $\varnothing 16$  to  $\varnothing 100$  mm



Refer to Intro 17 for details.



### JIS symbol

- 5 port valve
- 2-position single solenoid

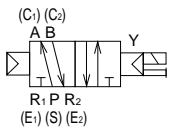

- 2-position double solenoid

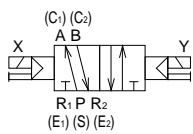

- 3-position
- all ports closed

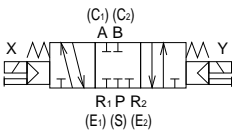

- 3-position A/B/R connection

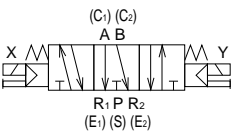

- 3-position P/A/B connection

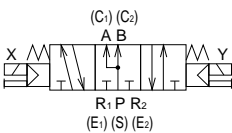

### Common specifications

Descriptions	
Valve and operation type	Pilot operated spool valve
Working fluid	Compressed air
Max. working pressure MPa	1.0
Min. working pressure MPa	Refer to the individual specifications below.
Withstanding pressure MPa	1.5
Ambient temperature °C	-10 to 60 (no freezing)
Fluid temperature °C	5 to 60
Lubrication	Not required (when lubricating, use turbine oil ISO VG32.)
Protective structure	Dust proof
Vibration/impact m/s <sup>2</sup>	50 or less / 300 or less
Working environment	Containing corrosive gas is impermissible.

Note 1: Ambient temperature refers to the temperature for storage and installation, and differs from fluid temperature, which applies during operation.

### Electric specifications

Descriptions		(A)4F0 to 1	4F2/3	
Rated voltage	AC	100, 200 (50 / 60Hz)		
	DC	12, 24		
Rated voltage fluctuation range		±10%		
Starting current	AC	100 V	0.056 / 0.044	0.170 / 0.140
		200 V	0.034 / 0.026	0.090 / 0.070
	A DC	12 V	0.150	0.500
		24 V	0.075	0.250
Holding current	AC	100 V	0.028 / 0.022	0.100 / 0.080
		200 V	0.017 / 0.013	0.050 / 0.040
	A DC	12 V	0.150	0.500
		24 V	0.075	0.250
Power consumption	AC	100 V	1.8 / 1.4	5.0 / 4.0
		200 V	2.1 / 1.6	5.0 / 4.0
	W DC	12 V	1.8	6
		24 V	1.8	6
Heat proof class		B (molded coil)		

Note1: The 100 VAC 50/60 Hz rated voltage can be used at 110 VAC 60 Hz, and 200 VAC 50/60 Hz can be used at 220 VAC 60 Hz.

### Individual specifications

Descriptions		(A)4F0 Note 1	4F1	4F2	4F3		
Min. working pressure MPa	2-position	Single solenoid	0.15	0.10	0.10		
		Double solenoid					
	3-position	All ports closed	0.20	0.15	0.15		
		A/B/R connection					
	P/A/B connection	-	-	-			
Port size	Note 2	M5	Rp 1/8	Rp 1/8	Rp 1/4	Rp 1/4	Rp 3/8
Response time	Note 3	ms	30	30	50	50	
Weight kg	2-position	Single solenoid	0.13	0.18	0.56	0.66	
		Double solenoid	0.18	0.22	0.86	0.94	
	3-position	-	0.32	1.10	1.40		

Note 1: (A) is A4F010 for the single type.

Note 2: G and NPT threads are usable for the (A) 4F0, 4F1, 4F2, and 4F3 piping port threads. Contact CKD for details.

Note 3: Response time is the value when supply pressure 0.5 MPa, not lubricated and ON. The value varies depending on pressure and quality of lubricant.



## Flow characteristics

Model no.	Solenoid position	Port size	C (dm <sup>3</sup> / (s·bar))	b		
(A) 4F0 Note 2	2-position	Single solenoid	M5	0.61	0.35	
		Double solenoid				
	2-position	Single solenoid	Rp1/8	0.74	0.27	
		Double solenoid				
4F1	2-position	Single solenoid	Rp1/8	2.0	0.33	
		Double solenoid				
	3-position	All ports closed	Rp1/4	1.5	0.31	
		A/B/R connection		1.6	0.29	
4F2	2-position	Single solenoid	Rp1/4	3.0	0.33	
		Double solenoid				
	3-position	All ports closed		2.5	0.43	
		A/B/R connection				
4F3	2-position	Single solenoid	Rp1/4	3.9	0.42	
		Double solenoid				
	3-position	All ports closed		4.0	0.35	
		A/B/R connection		4.5	0.42	
		P/A/B connection		4.0	0.35	
	2-position	Single solenoid		Rp3/8	5.8	0.42
		Double solenoid				
	3-position	All ports closed			4.4	0.42
A/B/R connection		5.1	0.46			
P/A/B connection		4.4	0.42			

Note 1: Effective sectional area S and sonic conductance C are converted as  $S \doteq 5.0 \times C$ .  
 Note 2: (A) is A4F010 for the single type.

### Copper and PTFE free

- Flow path free of copper-based and PTFE-based materials

\*\* - Voltage - **P6**

(4F0 not available)

MN3E0
MN4E0
4GA/B
M4GA/B
MN4GA/B
4GA/B (Master)
W4GA/B2
W4GB4
MN3S0
MN4S0
4TB
4L2-4/LMF0
4SA/B0
4SA/B1
4KA/B
<b>4F</b>
PV5G/CMF
PV5/CMF
3MA/B0
3PA/B
P/M/B
NP/NAP/NVP
4F*0E
HMV
HSV
2QV
3QV
SKH
PCD/FS/FD
Ending

Discrete 5 port pilot operated valve

# 4F0 to 3 Series

## Discrete valve: Body porting

### Discrete valve: How to order body porting

MN3E0
MN4E0
4GA/B
M4GA/B
MN4GA/B
4GA/B (Master)
W4GA/B2
W4GB4
MN3S0
MN4S0
4TB
4L2-4/LMFO
4SA/B0
4SA/B1
4KA/B
<b>4F</b>
PV5G/CMF
PV5/CMF
3MA/B0
3PA/B
P/MB
NP/NAP/NVP
4F*0E
HMV
HSV
2QV
3QV
SKH
PCD/FS/FD
Ending



**A** Model no.

4F0	4F1	4F2	4F3
-----	-----	-----	-----

Symbol	Descriptions	4F0	4F1	4F2	4F3
<b>B Solenoid position</b>					
1	2-position single solenoid	●	●	●	●
2	2-position double solenoid	●	●	●	●
3	3-position all ports closed		●	●	●
4	3-position A/B/R connection		●	●	●
5	3-position P/A/B connection				●
<b>C Port size Note 3</b>					
M5	M5	●			
06	Rp1/8		●		
08	Rp1/4		●	●	●
10	Rp3/8				●
<b>D Manual override</b>					
M1	Locking	●	●		
Blank	Locking			●	●
Blank	Non-locking	●	●		
M2	Non-locking			●	●
M3	Locking with manual lever			●	●
M4	Non-locking with dust proof cover	●	●		
M6	Non-locking upward	●	●		
R	Manual override position change	●	●	●	●
<b>E Electric connection</b>					
Refer to the next page for wire connections.					
<b>F Other options</b>					
Blank	No option	●	●	●	●
P	Mounting bracket (L shaped bracket) (2-position single solenoid)	●	●	●	●
P1	Mounting bracket (U shaped bracket)	●	●	●	●
S	Surge suppressor (variable resistor) attached	●	●	●	●
H	Check valve attached (Applicable to only 3-position all ports closed)			●	●
N	Plug attached (3 port valve)	●	●	●	●
NC	3 way valve with plug assembly (C1: A. E1: R1)	●	●	●	●
NO	3 way valve with plug assembly (C2: B. E2: R2)	●	●	●	●
<b>G Voltage</b>					
AC100V	100 VAC 50/60Hz	●	●	●	●
AC200V	200 VAC 50/60Hz	●	●	●	●
DC12V	12 VDC	●	●	●	●
DC24V	24 VDC	●	●	●	●
AC110V	110 VAC 50/60Hz	●	●	●	●
AC220V	220 VAC 50/60Hz	●	●	●	●

### ⚠ Note on model no. selection

- Note 1: R1 and R2 for 4F0 are M5.
- Note 2: R1 and R2 for 4F1 are Rp1/8.
- Note 3: Rc threads and NPT threads are available for the piping port threads. Contact CKD for information.
- Note 4: When selecting the DIN terminal box for the lock type with a manual lever, the terminal box must face outward during use.

**G** Voltage

### <Example of model number>

#### 4F340-08-M2P1-AC100V

- A** Model: 4F3
- B** Solenoid position : 3-position A/B/R connection
- C** Port size : Rp1/4
- D** Manual override : Non-locking
- E** Electric connection : Blank, DIN terminal box (Pg11)
- F** Other options : Mounting bracket
- G** Voltage : 100 VAC

### (Electric connection list)

		A Model no.			
		4F0	4F1	4F2	4F3
<b>E Electric connection</b>					
<b>Small terminal box</b>					
<b>B</b>	No lead wire	●			
<b>Blank</b>	No lead wire		●		
<b>L</b>	No lead wire with light Note 3	●	●		
<b>L2</b>	Lead wire length (300 mm) with light Note 3	●	●		
<b>DIN terminal box</b>					
<b>Blank</b>	DIN terminal box (Pg11)			●	●
<b>L</b>	DIN terminal box (Pg11) with light Note 4			●	●
<b>F</b>	DIN terminal box (G1/2)			●	●
<b>C-connector (lead wire lateral)</b>					
<b>C</b>	Lead wire length (300 mm)	●	●		
<b>C00</b>	Lead wire length (500 mm)	●	●		
<b>C01</b>	Lead wire length (1000 mm)	●	●		
<b>C02</b>	Lead wire length (2000 mm)	●	●		
<b>C03</b>	Lead wire length (3000 mm)	●	●		
<b>C1</b>	No lead wire	●	●		
<b>C2</b>	Lead wire length (300 mm) with surge suppressor / light	●	●		
<b>C20</b>	Lead wire length (500 mm) with surge suppressor / light	●	●		
<b>C21</b>	Lead wire length (1000 mm) with surge suppressor / light	●	●		
<b>C22</b>	Lead wire length (2000 mm) with surge suppressor / light	●	●		
<b>C23</b>	Lead wire length (3000 mm) with surge suppressor / light	●	●		
<b>C3</b>	No lead wire with surge suppressor / light	●	●		
<b>D-connector (lead wire upward)</b>					
<b>D</b>	Lead wire length (300 mm)	●	●		
<b>D00</b>	Lead wire length (500 mm)	●	●		
<b>D01</b>	Lead wire length (1000 mm)	●	●		
<b>D02</b>	Lead wire length (2000 mm)	●	●		
<b>D03</b>	Lead wire length (3000 mm)	●	●		
<b>D1</b>	No lead wire	●	●		
<b>D2</b>	Lead wire length (300 mm) with surge suppressor / light	●	●		
<b>D20</b>	Lead wire length (500 mm) with surge suppressor / light	●	●		
<b>D21</b>	Lead wire length (1000 mm) with surge suppressor / light	●	●		
<b>D22</b>	Lead wire length (2000 mm) with surge suppressor / light	●	●		
<b>D23</b>	Lead wire length (3000 mm) with surge suppressor / light	●	●		
<b>D3</b>	No lead wire with surge suppressor / light	●	●		
<b>Grommet lead wire</b>					
<b>Blank</b>	Grommet lead wire	●			
<b>E</b>	Grommet lead wire		●	●	●
<b>E1</b>	Conduit lead wire (CTC19)			●	●
<b>E2</b>	Conduit lead wire (G1/2)			●	●
<b>B1</b>	Conduit lead wire round terminal box (G3/4)			●	●
<b>B</b>	Conduit lead wire round terminal box (G1/2)			●	●
<b>BL</b>	Conduit lead wire round terminal box (G1/2) with light Note 5			●	●
<b>G</b>	Conduit lead wire round terminal box gland (A-15a)			●	●
<b>GL</b>	Conduit lead wire round terminal box gland (A-15a) with light Note 5			●	●

Note 4: The L and L2 DC type have a built-in surge suppressor.  
 (Refer to page 887 for the circuit drawings with light and surge suppressor.)  
 Note 5: BL/GL 12VDC are not available.

MN3E0
MN4E0
4GA/B
M4GA/B
MN4GA/B
4GA/B (Master)
W4GA/B2
W4GB4
MN3S0
MN4S0
4TB
4L2-4/LMF0
4SA/B0
4SA/B1
4KA/B
<b>4F</b>
PV5G/CMF
PV5/CMF
3MA/B0
3PA/B
P/M/B
NP/NAP/NVP
4F*0E
HMV
HSV
2QV
3QV
SKH
PCD/FS/FD
Ending

Discrete 5 port pilot operated valve

# 4F0/4F1 Series

Discrete valve: Body porting

## Internal structure and parts list

### 4A4F010

● 2-position single solenoid

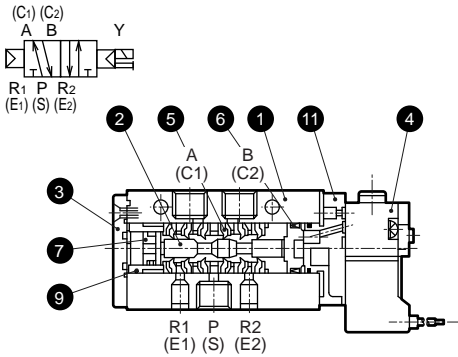

### 4F110

● 2-position single solenoid

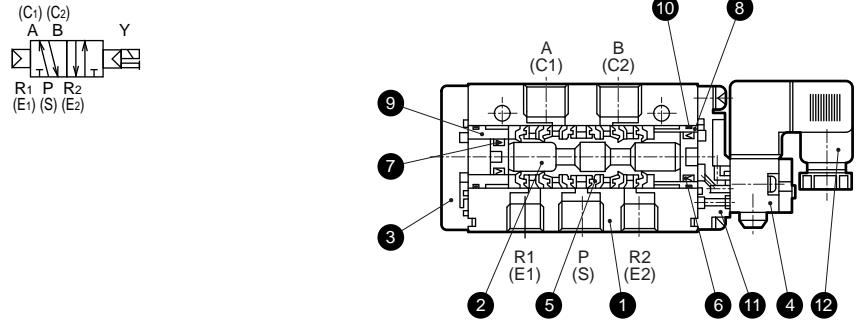

### 4F020

● 2-position double solenoid

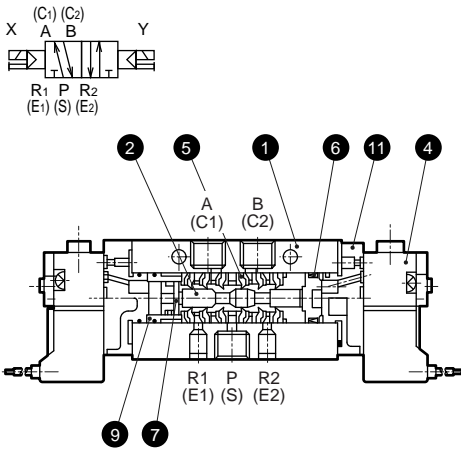

### 4F120

● 2-position double solenoid

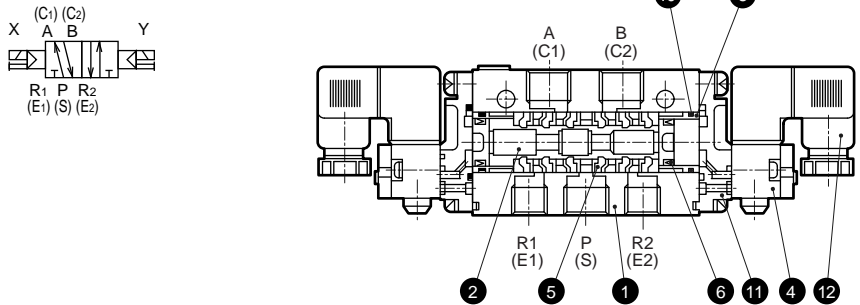

### 4F

### 4F130

● 3-position

All ports closed

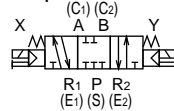

### 4F140

A/B/R connection

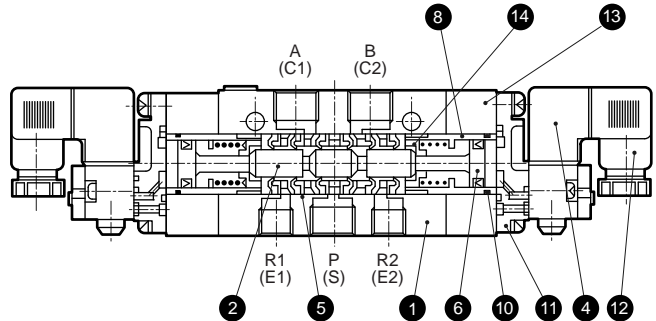
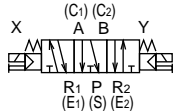

## Main parts list

## Repair parts list

No.	Parts name	Material	No. / parts name		5	6	7	4
			Model no.	Repair kit				
1	Body	Aluminum alloy die-casting	A4F010	A4F010-K	4F9-126	4F9-124	4F9-125	Discrete 4F9-miniature pneumatic valve model no. (Basic 4F9-P5132-MOE-[Voltage])
2	Valving element (spool)	Aluminum	4F020	4F020-K				
3	Cap	Aluminum alloy die-casting	4F110	4F110-K	4F9-112	4F9-110	4F9-111	Discrete 4F9-miniature pneumatic valve model no. (Basic P5132-MOB-[Voltage])
4	Coil assembly (solenoid valve)	-	4F120	4F120-K				
5	Seal assembly	-	4F130	4F130-K				
6	Piston (A) assembly	-	4F140					
7	Piston (B) assembly	-						
8	Cylinder A	Aluminum						
9	Cylinder B	Aluminum						
10	O ring	Nitrile rubber						
11	Pilot valve body	Aluminum alloy die-casting						
12	Small terminal box	-						
13	Body block	Aluminum alloy die-casting						
14	Spring retainer	Stainless steel						

\*: Consumables are stocked as a kit, and cannot be purchased individually. (The kit consists of the seal assembly and piston (A) and (B) assemblies. The coil assembly is not included.)

### Internal structure and parts list

#### 4F210/4F310

● 2-position single solenoid

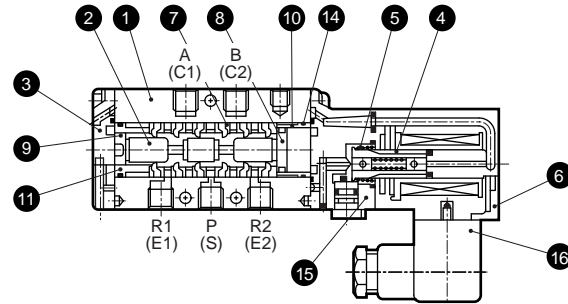
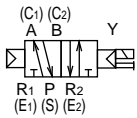

#### 4F220/4F320

● 2-position double solenoid

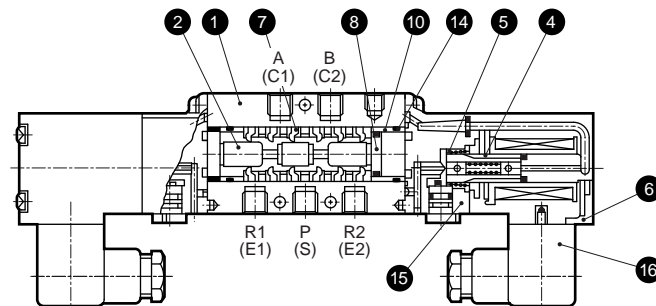
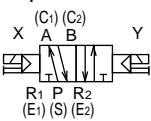

#### 4F230/4F330

● 3-position  
all ports closed

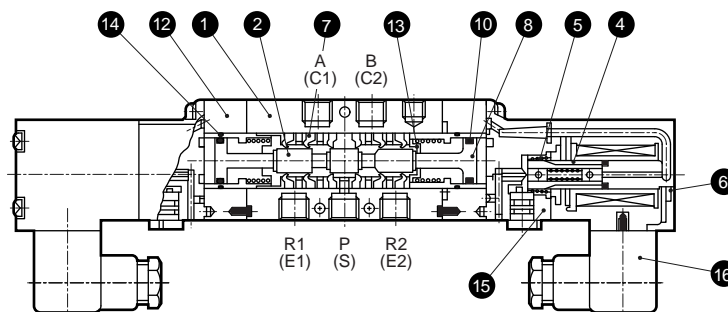
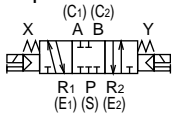

#### 4F240/4F340

A/B/R connection

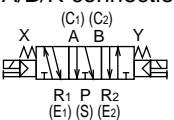

#### 4F350

P/A/B connection

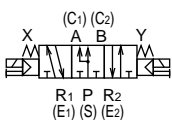

### Main parts list

No.	Parts name	Material	No. / parts name	
			Model no.	Repair kit
1	Body	Aluminum alloy die-casting	4F210	4F210-K
2	Valving element (spool)	Aluminum	4F220	4F220-K
3	Cap	Aluminum alloy die-casting	4F230	4F230-K
4	Plunger	-	4F240	4F240-K
5	Plunger spring	-	4F310	4F310-K
6	Coil assembly	-	4F320	4F320-K
7	Seal assembly	-	4F330	4F330-K
8	Piston (A) assembly	-	4F340	4F340-K
9	Piston (B) assembly	-	4F350	4F350-K
10	Cylinder A	Aluminum		
11	Cylinder B	Aluminum		
12	Body block	Aluminum alloy die-casting		
13	Spring retainer	Stainless steel		
14	O ring	Nitrile rubber		
15	Pilot valve body	Aluminum alloy die-casting		
16	DIN terminal box	-		

### Repair parts list

No.	7	8	9	6
	Seal assembly	Piston (A) assembly	Piston (B) assembly	Coil assembly *
7	4F9-105	4F9-101	4F9-102	4F2*0-
8	4F9-106	4F9-113	-	[Electric connection]-
9	4F9-106	4F9-104	4F9-103	COIL-[Voltage]
6	4F9-106	4F9-114	-	4F3*0-
				[Electric connection]-
				COIL-[Voltage]

\*: Consumables are stocked as a kit, and cannot be purchased individually. (The kit consists of the seal assembly and piston (A) and (B) assemblies. The coil assembly is not included.)

\*: Plunger assembly is included with a coil assembly.

MN3E0
MN4E0
4GA/B
M4GA/B
MN4GA/B
4GA/B (Master)
W4GA/B2
W4GB4
MN3S0
MN4S0
4TB
4L2-4/ LMFO
4SA/B0
4SA/B1
4KA/B
<b>4F</b>
PV5G/ CMF
PV5/ CMF
3MA/B0
3PA/B
P/M/B
NP/NAP/ NVP
4F*0E
HMV
HSV
2QV
3QV
SKH
PCD/ FS/FD
Ending

Discrete 5 port pilot operated valve

# (A)4F0 Series

Discrete valve: Body porting

## Dimensions

### A4F010

● 2-position single solenoid: (grommet lead wire)

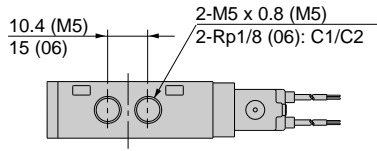

### 4F020

● 2-position double solenoid: (grommet lead wire)

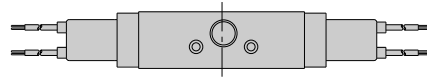
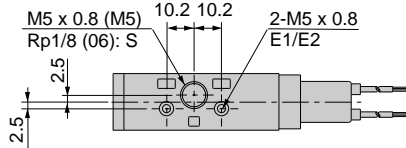
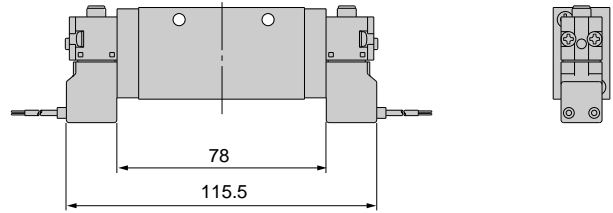
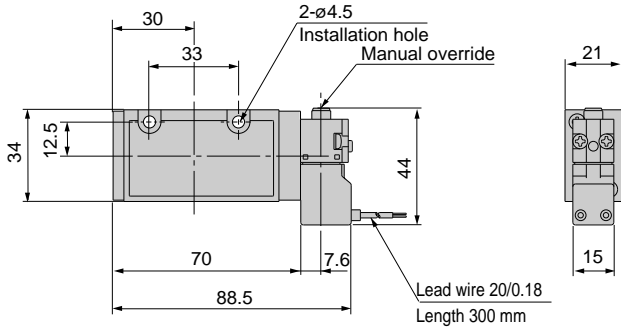
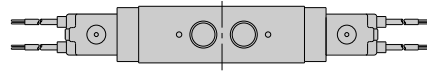

● Mounting bracket: (P: 2-position single solenoid only)

● Mounting bracket: (P1)

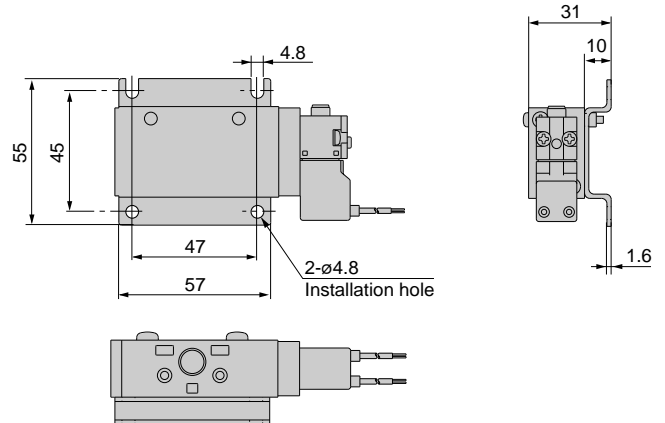
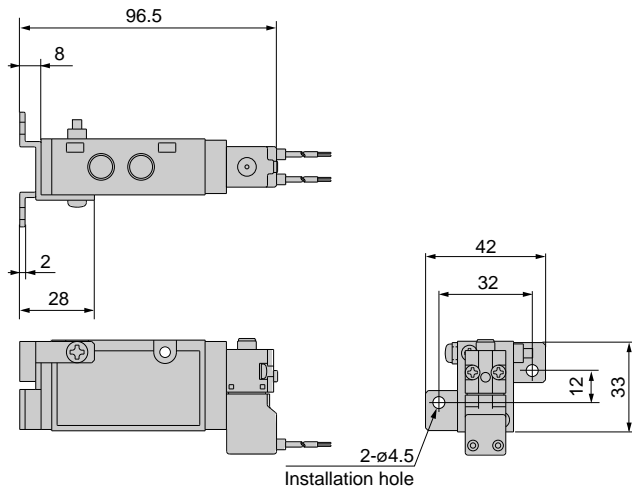

### Dimensions

⬇ 2-position single solenoid

⬇ 2-position double solenoid

● Small terminal box: (B)

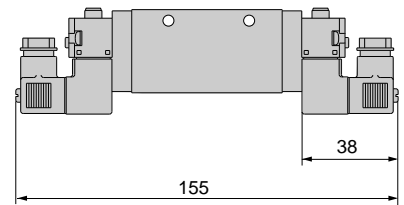
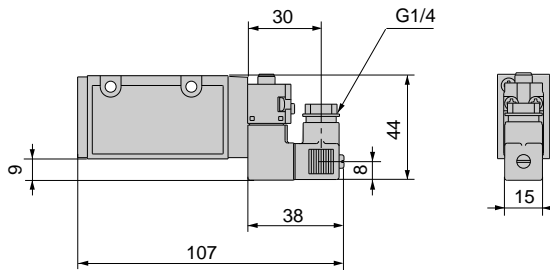

● Small terminal box with light: (L/L2)

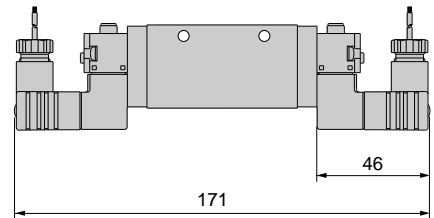
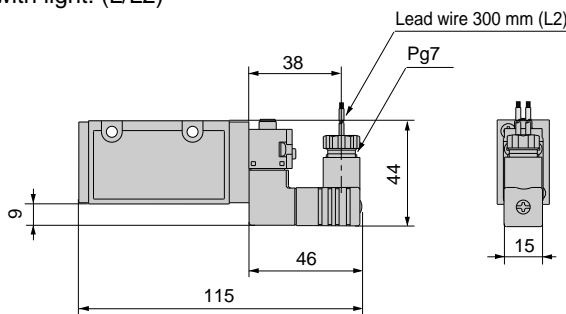

● C-connector: (C, C0\*, C1, C2, C2\*, C3)

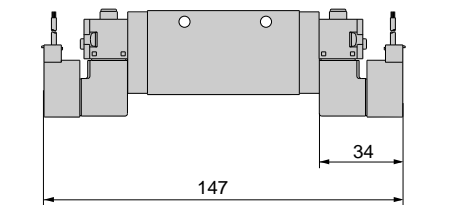
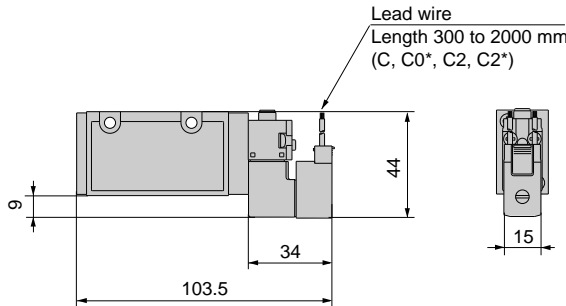

● D-connector: (D, D0\*, D1, D2, D2\*, D3)

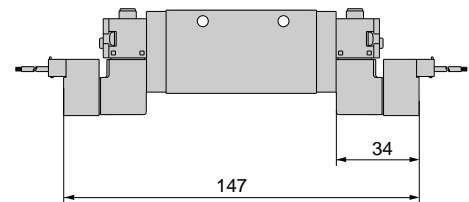
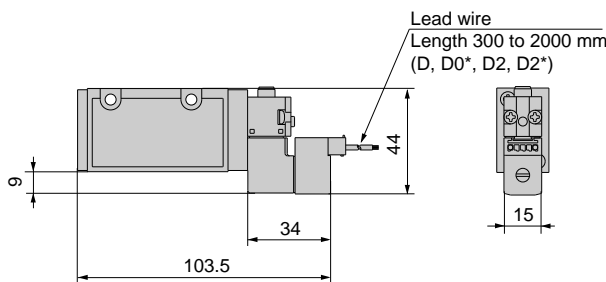

● Manual override position change: (R)

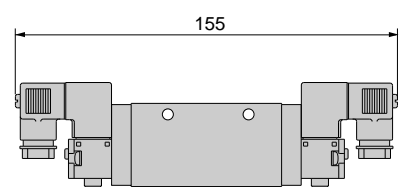
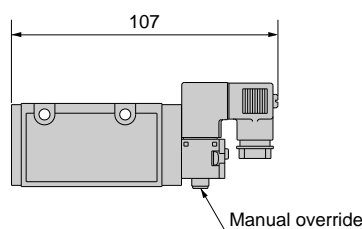

MN3E0
MN4E0
4GA/B
M4GA/B
MN4GA/B
4GA/B (Master)
W4GA/B2
W4GB4
MN3S0
MN4S0
4TB
4L2-4/LMF0
4SA/B0
4SA/B1
4KA/B
<b>4F</b>
PV5G/CMF
PV5/CMF
3MA/B0
3PA/B
P/M/B
NP/NAP/NVP
4F*0E
HMV
HSV
2QV
3QV
SKH
PCD/FS/FD
Ending

Discrete  
5 port pilot operated valve





### Dimensions

- Small terminal box with light: (L/L2)

① 2-position single solenoid

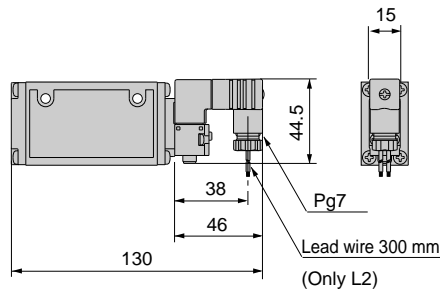

② 2-position double solenoid, 3-position

\* The drawing shows 2-position double solenoid.

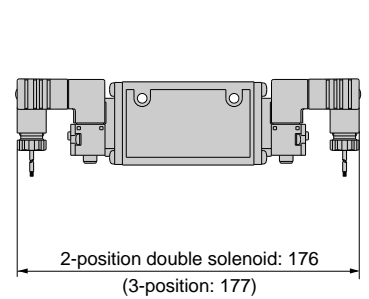

- Grommet lead wire: (E)

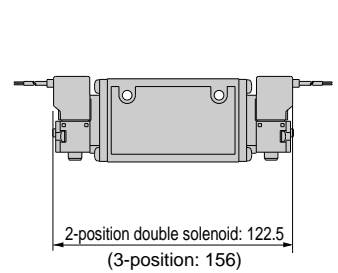
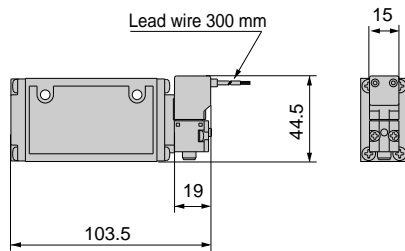

- C-connector: (C, C0\*, C1, C2, C2\*, C3)

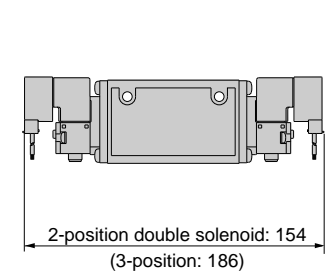
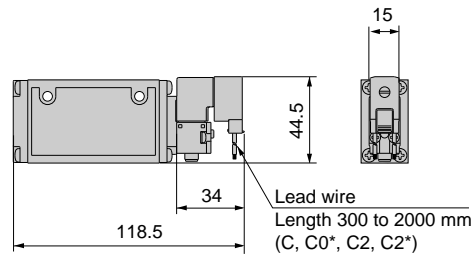

- D-connector: (D, D0\*, D1, D2, D2\*, D3)

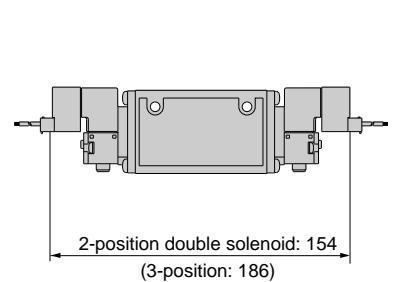
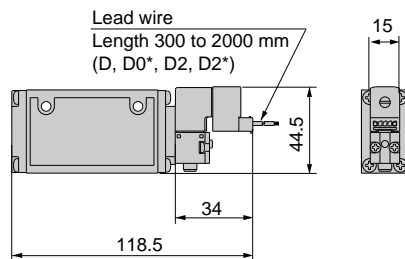

- Manual override position change: (R)

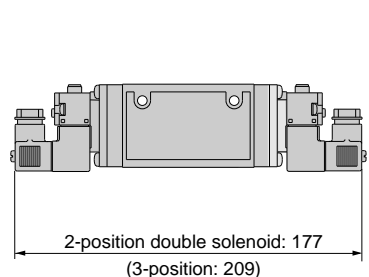
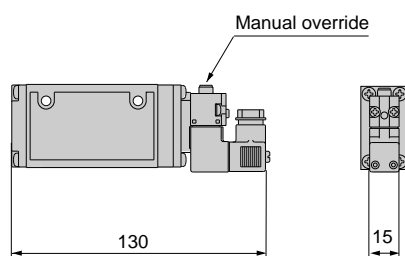

MN3E0
MN4E0
4GA/B
M4GA/B
MN4GA/B
4GA/B (Master)
W4GA/B2
W4GB4
MN3S0
MN4S0
4TB
4L2-4/LMF0
4SA/B0
4SA/B1
4KA/B
<b>4F</b>
PV5G/CMF
PV5/CMF
3MA/B0
3PA/B
P/M/B
NP/NAP/NVP
4F*0E
HMV
HSV
2QV
3QV
SKH
PCD/FS/FD
Ending

Discrete 5 port pilot operated valve

# 4F2 Series

Discrete valve: Body porting

## Dimensions

MN3E0
MN4E0
4GA/B
M4GA/B
MN4GA/B
4GA/B (Master)
W4GA/B2
W4GB4
MN3S0
MN4S0
4TB
4L2-4/LMFO
4SA/B0
4SA/B1
4KA/B
<b>4F</b>
PV5G/CMF
PV5/CMF
3MA/B0
3PA/B
P/M/B
NP/NAP/NVP
4F*0E
HMV
HSV
2QV
3QV
SKH
PCD/FS/FD
Ending

### 4F210



● 2-position single solenoid: DIN terminal box

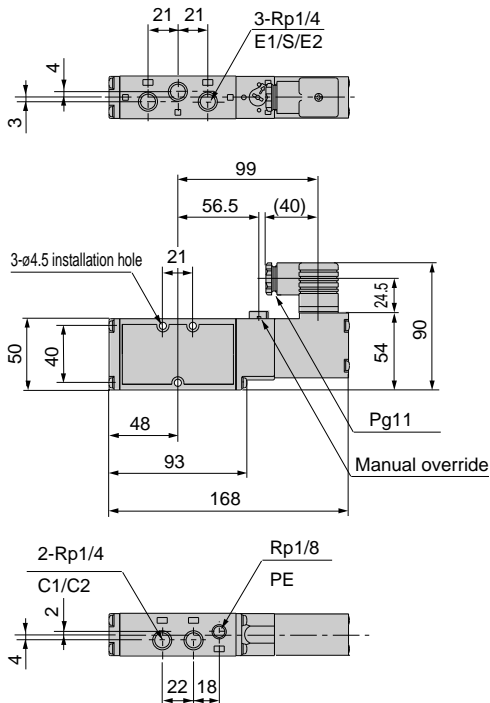

### 4F220



● 2-position double solenoid: DIN terminal box

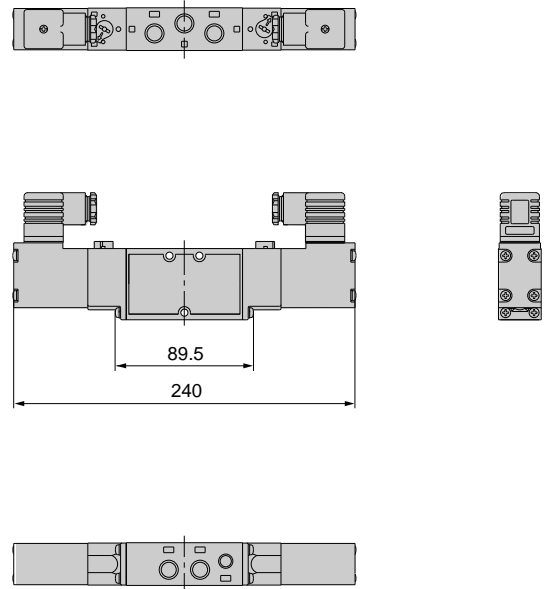

### 4F230



● 3-position: DIN terminal box

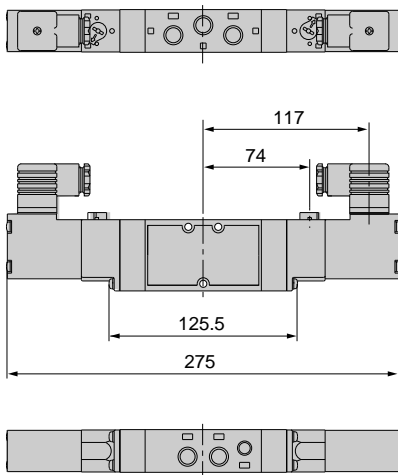

● Mounting bracket: (P: 2-position single solenoid dedicated)

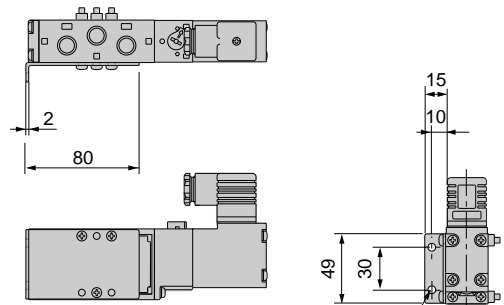

● Mounting bracket: (P1)

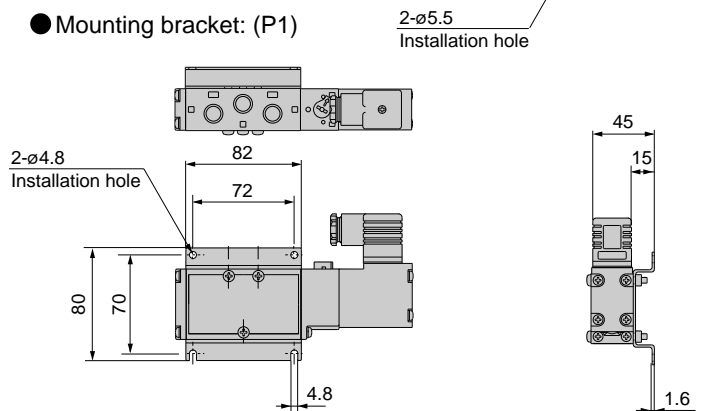

\* Refer to page 954 for a check valve.

### Dimensions

- DIN terminal box with indicator light: (L)

① 2-position single solenoid

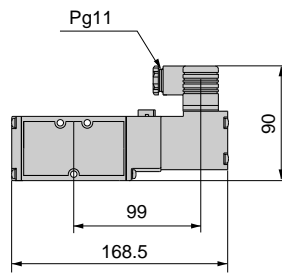

② 2-position double solenoid, 3-position  
\* The drawing shows 2-position double solenoid.

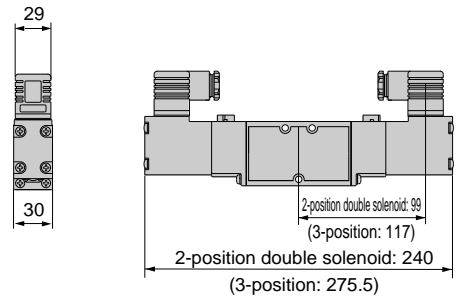

- Grommet lead wire: (E)

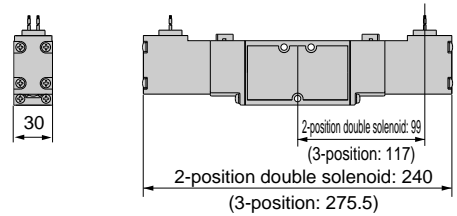
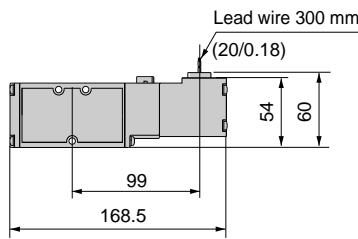

- Conduit lead wire: (E1/E2)

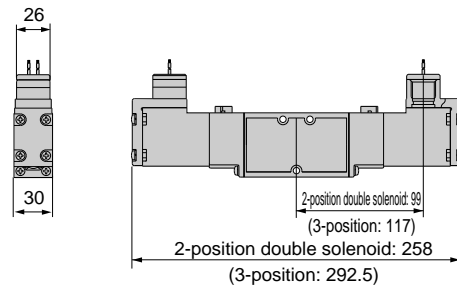
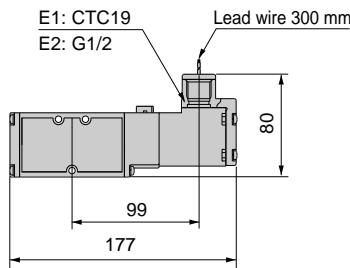

- Round terminal box: (B1/B/BL)

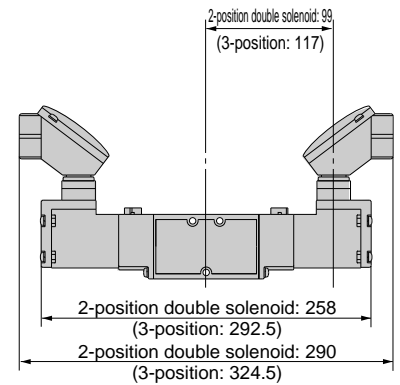
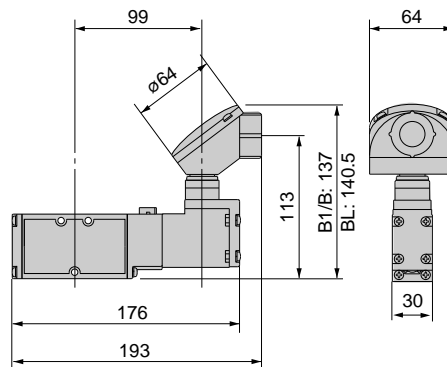

- Manual override position change: (R)

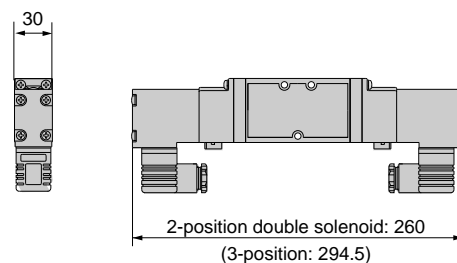
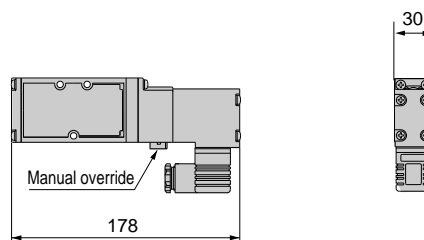

MN3E0  
MN4E0

4GA/B

M4GA/B

MN4GA/B

4GA/B  
(Master)

W4GA/B2

W4GB4

MN3S0  
MN4S0

4TB

4L2-4/  
LMF0

4SA/B0

4SA/B1

4KA/B

**4F**

PV5G/  
CMF

PV5/  
CMF

3MA/B0

3PA/B

P/M/B

NP/NAP/  
NVP

4F\*OE

HMV  
HSV

2QV  
3QV

SKH

PCD/  
FS/FD

Ending

Discrete  
5 port pilot operated valve

# 4F3 Series

Discrete valve: Body porting

## Dimensions

### 4F310



● 2-position single solenoid: DIN terminal box

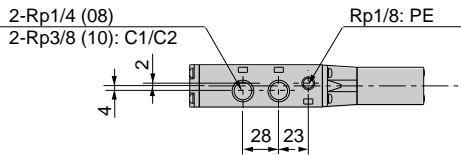
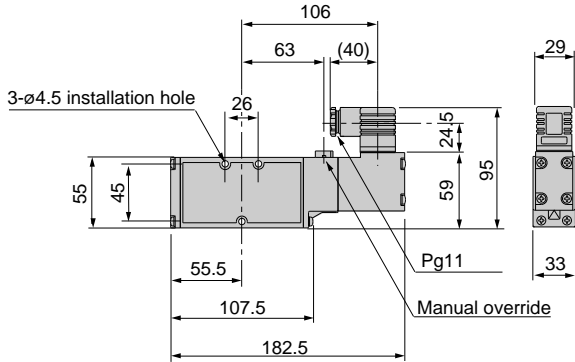
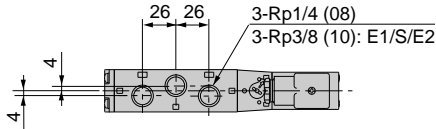

### 4F320



● 2-position double solenoid: DIN terminal box

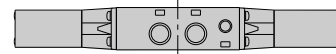
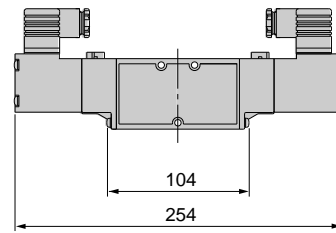
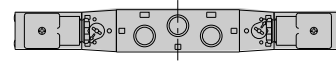

### 4F3<sup>3</sup>/<sub>5</sub>0



● 3-position: DIN terminal box

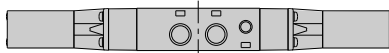
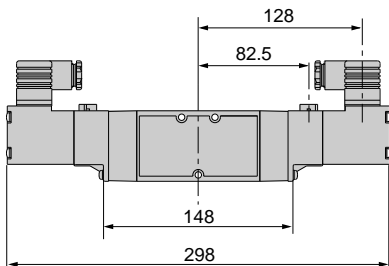
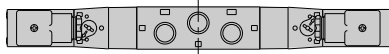

● Mounting bracket: (P: 2-position single solenoid dedicated)

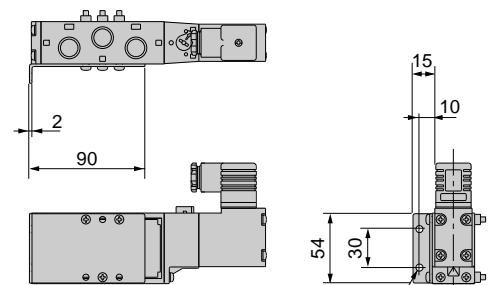

● Mounting bracket: (P1)

2-ø5.5  
Installation hole

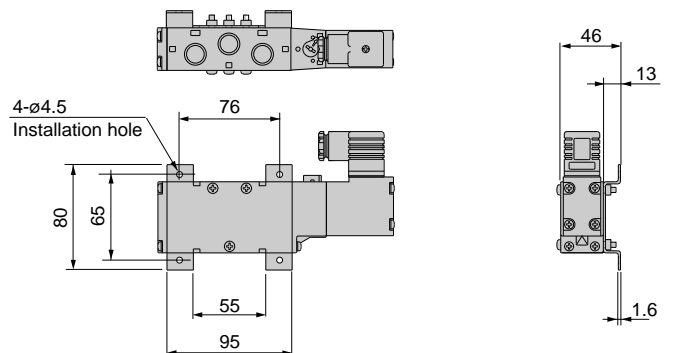

\* Refer to page 954 for a check valve.

### Dimensions

● DIN terminal box with indicator light: (L)

① 2-position single solenoid

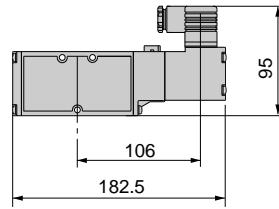

② 2-position double solenoid, 3-position  
\* The drawing shows 2-position double solenoid.

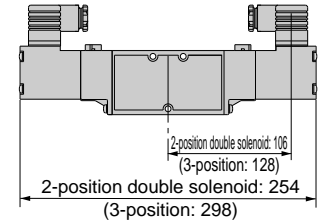

● Grommet lead wire: (E)

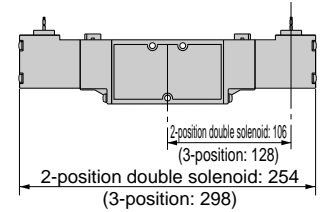
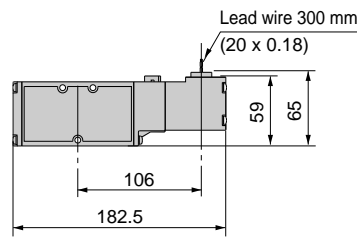

● Conduit lead wire: (E1/E2)

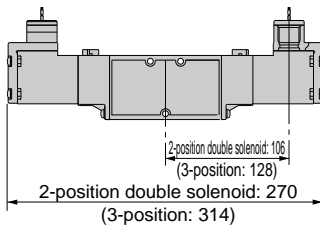
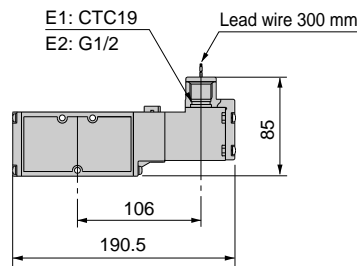

● Round terminal box: (B1/B/BL)

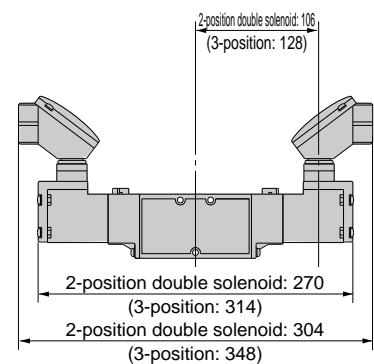
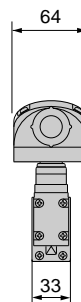
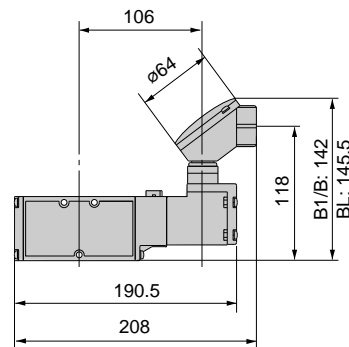

● Manual override position change: (R)

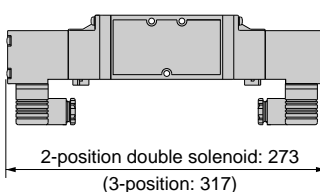
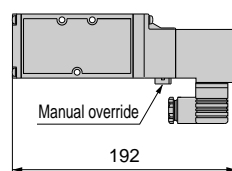

MN3E0
MN4E0
4GA/B
M4GA/B
MN4GA/B
4GA/B (Master)
W4GA/B2
W4GB4
MN3S0
MN4S0
4TB
4L2-4/LMF0
4SA/B0
4SA/B1
4KA/B
<b>4F</b>
PV5G/CMF
PV5/CMF
3MA/B0
3PA/B
P/M/B
NP/NAP/NVP
4F*OE
HMV
HSV
2QV
3QV
SKH
PCD/FS/FD
Ending

Discrete 5 port pilot operated valve



# Discrete valve: Sub-plate porting

## 5 port pilot operated pneumatic valve

# 4F4/5/6/7 Series

● Applicable cylinder bore size:  $\varnothing 63$  to  $\varnothing 250$

Refer to Intro 17 for details.



### JIS symbol

- 5 port valve
- 2-position single solenoid

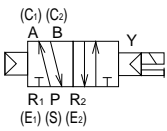

- 2-position double solenoid

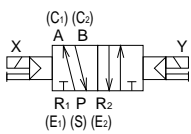

- 3-position
- all ports closed

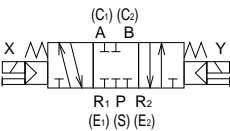

- 3-position A/B/R connection

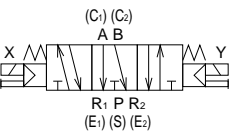

- 3-position P/A/B connection

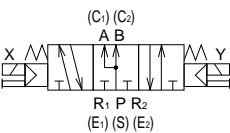

- External pilot

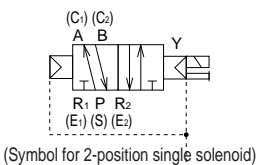

(Symbol for 2-position single solenoid)

### Common specifications

Descriptions	
Valve and operation type	Pilot operated spool valve
Working fluid	Compressed air
Max. working pressure MPa	1.0
Min. working pressure MPa	Refer to the individual specifications below.
Withstanding pressure MPa	1.5
Ambient temperature °C	-10 to 60 (no freezing)
Fluid temperature °C	5 to 60
Lubrication	Not required (when lubricating, use turbine oil ISO VG32.)
Protective structure	Dust proof
Vibration/impact m/s <sup>2</sup>	50 or less / 300 or less
Working environment	Containing corrosive gas is impermissible.

Note 1: Ambient temperature refers to the temperature for storage and installation, and differs from fluid temperature, which applies during operation.

Note 2: The working pressure range is 0 to 1.0 MPa when the external pilot (option symbol: K) is selected. Set the external pilot pressure between 0.15 and 1.0 MPa.

### Electric specifications

Descriptions		4F4 to 7		
Rated voltage	AC	100, 200 (50 / 60Hz)		
	V	DC	12, 24	
Rated voltage fluctuation range		±10%		
Starting current	AC	100 V	0.170 / 0.140	
		200 V	0.090 / 0.070	
	A	DC	12 V	0.500
		24 V	0.250	
Holding current	AC	100 V	0.100 / 0.080	
		200 V	0.050 / 0.040	
	A	DC	12 V	0.500
		24 V	0.250	
Power consumption	AC	100 V	5.0 / 4.0	
		200 V	5.0 / 4.0	
	W	DC	12 V	6
		24 V	6	
Heat proof class		B (molded coil)		

Note1: The 100 VAC 50/60 Hz rated voltage can be used at 110 VAC 60 Hz, and 200 VAC 50/60 Hz can be used at 220 VAC 60 Hz.

### Individual specifications

Descriptions		4F4		4F5		4F6		4F7	
Min. working pressure MPa	2-position	Single solenoid		0.10	0.10	0.15		0.15	
		Double solenoid							
	3-position	All ports closed		0.15	0.15	0.15		0.15	
		A/B/R connection							
		P/A/B connection							
Port size	Note 1		Rc 1/4	Rc 3/8	Rc 3/8	Rc 1/2	Rc 1/2	Rc 3/4	Rc 1
Response time	Note 2		ms		60	70	200		300
Weight kg	2-position	Single solenoid		1.06	1.50	2.30		4.20	
		Double solenoid		1.30	1.70	2.60		4.50	
	3-position				1.70	2.00	3.10		5.60

Note 1: G threads and NPT threads are available for the piping port threads. Contact CKD for information.

Note 2: Response time is the value when supply pressure 0.5 MPa, not lubricated and ON. The value varies depending on pressure and quality of lubricant.

### Flow characteristics

Model no.	Solenoid position	Port size	C (dm <sup>3</sup> / (s·bar))	b	S (mm <sup>2</sup> )	
4F4	2-position	Rc1/4 Rc3/8	Single solenoid	5.0	0.21	-
			Double solenoid			
	3-position		All ports closed	4.7	0.24	
			A/B/R connection	5.3	0.29	
			P/A/B connection	5.3	0.29	
4F5	2-position	Rc3/8 Rc1/2	Single solenoid	10	0.32	-
			Double solenoid			
	3-position		All ports closed	9.7	0.28	
			A/B/R connection	9.8	0.25	
			P/A/B connection			
4F6	2-position	Rc1/2 Rc3/4	Single solenoid	18	0.31	-
			Double solenoid			
	3-position		All ports closed	15	0.23	
			A/B/R connection			
			P/A/B connection			
4F7	2-position	Rc3/4 Rc1	Single solenoid	-	-	160
			Double solenoid			
	3-position		All ports closed			
			A/B/R connection			
			P/A/B connection			

Note 1: Effective sectional area S and sonic conductance C are converted as  $S \cong 5.0 \times C$ .

### Copper and PTFE free

- Flow path free of copper-based and PTFE-based materials

\*\* - Voltage - **P6**

MN3E0
MN4E0
4GA/B
M4GA/B
MN4GA/B
4GA/B (Master)
W4GA/B2
W4GB4
MN3S0
MN4S0
4TB
4L2-4/ LMF0
4SA/B0
4SA/B1
4KA/B
<b>4F</b>
PV5G/ CMF
PV5/ CMF
3MA/B0
3PA/B
P/M/B
NP/NAP/ NVP
4F*0E
HMV
HSV
2QV
3QV
SKH
PCD/ FS/FD
Ending

Discrete 5 port pilot operated valve

# 4F4 to 7 Series

## Discrete valve: Sub-plate porting

- MN3E0
- MN4E0
- 4GA/B
- M4GA/B
- MN4GA/B
- 4GA/B (Master)
- W4GA/B2
- W4GB4
- MN3S0
- MN4S0
- 4TB
- 4L2-4/LMFO
- 4SA/B0
- 4SA/B1
- 4KA/B
- 4F**
- PV5G/CMF
- PV5/CMF
- 3MA/B0
- 3PA/B
- P/M/B
- NP/NAP/NVP
- 4F\*0E
- HMV
- HSV
- 2QV
- 3QV
- SKH
- PCD/FS/FD
- Ending

### Discrete valve: How to order sub-plate porting



**A** Model no.

**B** Solenoid position

**C** Port size

**D** Manual override

**E** Electric connection

Note 1: The DC type with DIN terminal box with light (L) has a built-in surge suppressor. (Refer to page 887 for the circuit diagram of the type with a surge suppressor and light.)

**F** Other options

**G** Voltage

### ⚠ Note on model no. selection

- Note 2: Consult CKD for details on using vacuum with the external pilot (K) and exhaust pressurizing.
- Note 3: G threads and NPT threads are available for the piping port threads. Contact CKD for information.
- Note 4: When selecting the DIN terminal box for the lock type with a manual lever, the terminal box must face outward during use.
- Note 5: BL and GL 12VDC are not available.

### <Example of model number>

**4F440-08-M2P-AC100V**

- A** Model: 4F4
- B** Solenoid position : 3-position A/B/R connection
- C** Port size : Rc1/4
- D** Manual override : Non-locking
- E** Electric connection: Blank for DIN terminal box (Pg11)
- F** Other options : Mounting bracket
- G** Voltage : 100 VAC

**A** Model no.

4F4	4F5	4F6	4F7
-----	-----	-----	-----

Symbol	Descriptions				
<b>B Solenoid position</b>					
1	2-position single solenoid	●	●	●	●
2	2-position double solenoid	●	●	●	●
3	3-position all ports closed	●	●	●	●
4	3-position A/B/R connection	●	●	●	●
5	3-position P/A/B connection	●	●	●	●
<b>C Port size Note 3</b>					
08	Rc1/4	●			
10	Rc3/8	●	●		
15	Rc1/2		●	●	
20	Rc3/4			●	●
25	Rc 1				●
<b>D Manual override</b>					
Blank	Locking	●	●	●	●
M2	Non-locking	●	●	●	●
M3	Locking with manual lever	●	●	●	●
<b>E Electric connection</b>					
Blank	DIN terminal box (Pg11)	●	●	●	●
L	DIN terminal box (Pg11) with light	●	●	●	●
F	DIN terminal box (G1/2)	●	●	●	●
E	Grommet lead wire	●	●	●	●
E1	Conduit lead wire (CTC19)	●	●	●	●
E2	Conduit lead wire (G1/2)	●	●	●	●
B1	Round terminal box (G3/4)	●	●	●	●
B	Round terminal box (G1/2)	●	●	●	●
BL	Round terminal box (G1/2) with light	●	●	●	●
G	Round terminal box with gland (A-15a)	●	●	●	●
GL	Round terminal box with gland (A-15a), light	●	●	●	●
<b>F Other options</b>					
Blank	No option	●	●	●	●
K	External pilot	●	●	●	●
P	Mounting bracket (U bracket)	●	●	●	●
S	Surge suppressor (variable resistor) attached	●	●	●	●
H	Check valve attached (only for 3-position all ports closed)	●	●	●	●
N	Plug attached (3 port valve)	●	●	●	●
NC	3 way valve with plug assembly (C1: A. E1: R1)	●	●	●	●
NO	3 way valve with plug assembly (C2: B. E2: R2)	●	●	●	●
<b>G Voltage</b>					
AC100V	100 VAC 50/60Hz	●	●	●	●
AC200V	200 VAC 50/60Hz	●	●	●	●
DC12V	12 VDC	●	●	●	●
DC24V	24 VDC	●	●	●	●
AC110V	110 VAC 50/60Hz	●	●	●	●
AC220V	220 VAC 50/60Hz	●	●	●	●



### How to install discrete 4F4 to 7

● Installation

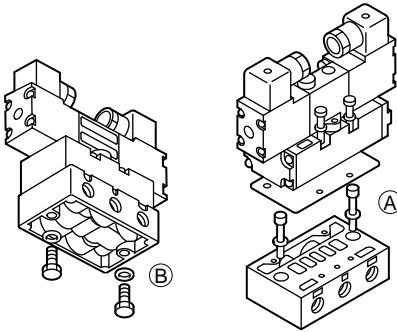

	For B	For A
<b>4F4</b>	M 8	M 6
<b>4F5</b>	M 8	M 6
<b>4F6</b>	M10	M 8
<b>4F7</b>	M12	M10

MN3E0
MN4E0
4GA/B
M4GA/B
MN4GA/B
4GA/B (Master)
W4GA/B2
W4GB4
MN3S0
MN4S0
4TB
4L2-4/LMF0
4SA/B0
4SA/B1
4KA/B
<b>4F</b>
PV5G/CMF
PV5/CMF
3MA/B0
3PA/B
P/M/B
NP/NAP/NVP
4F*0E
HMV
HSV
2QV
3QV
SKH
PCD/FS/FD
Ending

Discrete 5 port pilot operated valve

# 4F4/4F5 Series

Discrete valve: Sub-plate porting  
Internal structure and parts list

- MN3E0
- MN4E0
- 4GA/B
- M4GA/B
- MN4GA/B
- 4GA/B (Master)
- W4GA/B2
- W4GB4
- MN3S0
- MN4S0
- 4TB
- 4L2-4/LMFO
- 4SA/B0
- 4SA/B1
- 4KA/B
- 4F**
- PV5G/CMF
- PV5/CMF
- 3MA/B0
- 3PA/B
- P/M/B
- NP/NAP/NVP
- 4F\*0E
- HMV
- HSV
- 2QV
- 3QV
- SKH
- PCD/FS/FD
- Ending

## 4F410/4F510

● 2-position single solenoid

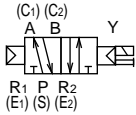

## 4F420/4F520

● 2-position double solenoid

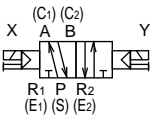

## 4F430/4F530

● 3-position  
all ports closed

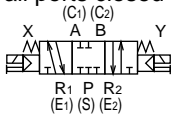

## 4F440/4F540

A/B/R connection

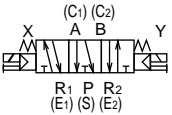

## 4F450/4F550

P/A/B connection

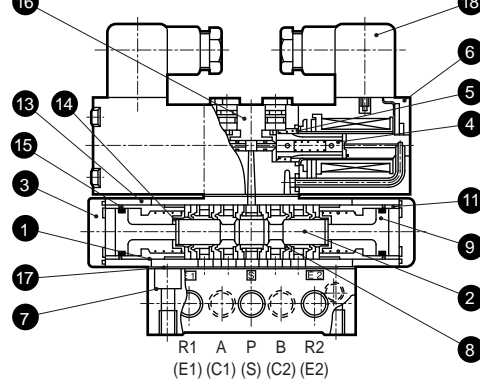
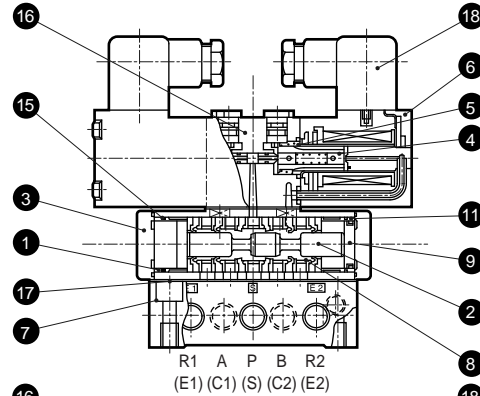
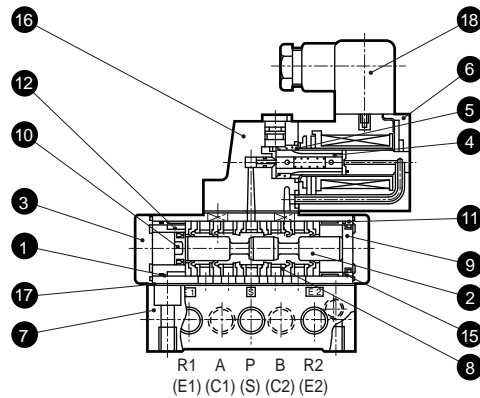
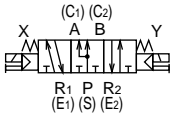

## Main parts list

No.	Parts name	Material	No. / parts name					
			8	9	10	8	9	10
			Model no.	Repair kit	Seal assembly	Piston (A) assembly	Piston (B) assembly	Coil assembly *
1	Body	Aluminum alloy die-casting	4F410	4F410-K				
2	Valving element (spool)	Aluminum	4F420	4F420-K				4F4*0-
3	Cap	Aluminum alloy die-casting	4F430		4F9-106			[Electric connection]-
4	Plunger	-	4F440	4F430-K				COIL-[Voltage]
5	Plunger spring	-	4F450					
6	Coil assembly	-	4F510	4F510-K		4F9-104	4F9-103	
7	Sub-plate	Aluminum alloy die-casting	4F520	4F520-K				
8	Seal assembly	-	4F530		4F9-107			4F5*0-
9	Piston (A) assembly	-	4F540	4F530-K		4F9-114		[Electric connection]-
10	Piston (B) assembly	-	4F550			4F9-108	4F9-109	COIL-[Voltage]
11	Cylinder A	Aluminum						
12	Cylinder B	Aluminum						
13	Body block	Aluminum alloy die-casting						
14	Spring retainer	Stainless steel						
15	O ring	Nitrile rubber						
16	Pilot valve body assembly	-						
17	Sub-plate gasket	Nitrile rubber						
18	DIN terminal box	-						

## Repair parts list

\*: Consumables are stocked as a kit, and cannot be purchased individually. (The kit consists of the seal assembly and piston (A) and (B) assemblies. The coil assembly is not included.)

\*: Plunger assembly is included with a coil assembly.

### Internal structure and parts list

#### 4F610/4F710

● 2-position single solenoid

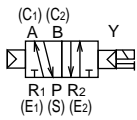

#### 4F620/4F720

● 2-position double solenoid

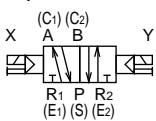

#### 4F630/4F730

● 3-position

all ports closed

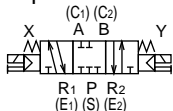

#### 4F640/4F740

A/B/R connection

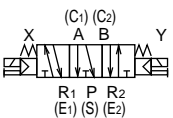

#### 4F650/4F750

P/A/B connection

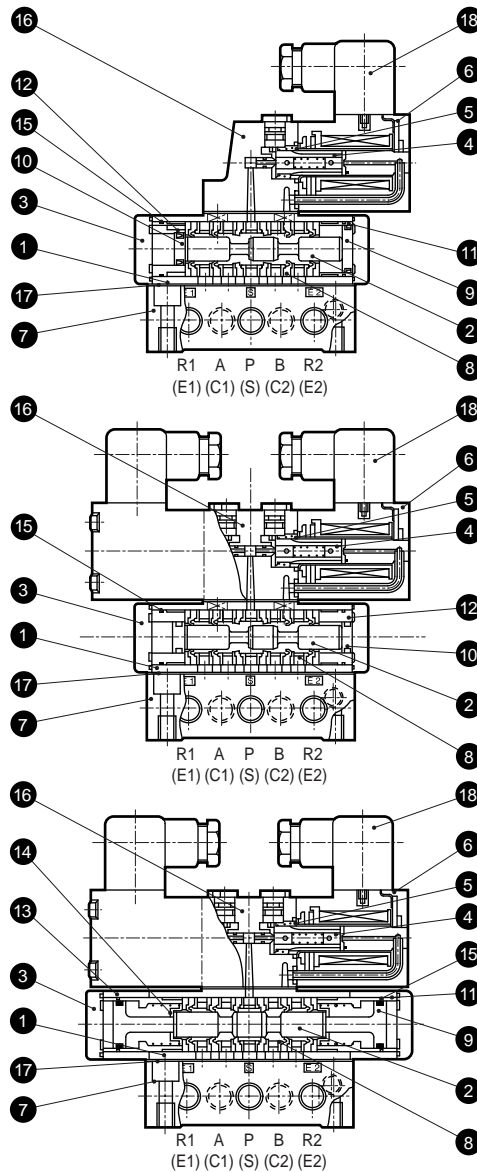
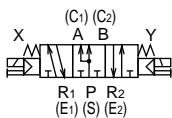

### Main parts list

No.	Parts name	Material	No. / parts name
			Model no.
1	Body	Aluminum alloy die-casting	4F610
2	Valving element (spool)	Aluminum	4F620
3	Cap	Aluminum alloy die-casting	4F630
4	Plunger	-	4F640
5	Plunger spring	-	4F650
6	Coil assembly	-	4F710
7	Sub-plate	Aluminum alloy die-casting	4F720
8	Seal assembly	-	4F730
9	Piston (A) assembly	-	4F740
10	Piston (B) assembly	-	4F750
11	Cylinder A	Aluminum	
12	Cylinder B	Aluminum	
13	Body block	Aluminum alloy die-casting	
14	Spring retainer	Stainless steel	
15	O ring	Nitrile rubber	
16	Pilot valve body assembly		
17	Sub-plate gasket	Nitrile rubber	
18	DIN terminal box	-	

### Repair parts list

No. / parts name	8	9	10	8	9	10	6
Model no.	Repair kits	Seal assembly	Piston (A) assembly	Piston (B) assembly	Coil assembly *		
4F610	4F610-K	4F9-118	4F9-117	4F9-116	4F6*0- [Electric connection]- COIL-[Voltage]		
4F620	4F620-K		-	-			
4F630	4F630-K		4F9-122	-			
4F710	4F710-K	4F9-119	4F9-121	4F9-120	4F7*0- [Electric connection]- COIL-[Voltage]		
4F720	4F720-K		-	-			
4F730	4F730-K		4F9-123	-			

\*: Consumables are stocked as a kit, and cannot be purchased individually. (The kit consists of the seal assembly and piston (A) and (B) assemblies. The coil assembly is not included.)

\*: Plunger assembly is included with a coil assembly.

MN3E0  
MN4E0  
4GA/B  
M4GA/B  
MN4GA/B  
4GA/B (Master)  
W4GA/B2  
W4GB4  
MN3S0  
MN4S0  
4TB  
4L2-4/  
LMF0  
4SA/B0  
4SA/B1  
4KA/B  
**4F**  
PV5G/  
CMF  
PV5/  
CMF  
3MA/B0  
3PA/B  
P/M/B  
NP/NAP/  
NVP  
4F\*0E  
HNV  
HSV  
2QV  
3QV  
SKH  
PCD/  
FS/FD  
Ending  
Discrete  
5 port pilot operated valve

# 4F4 Series

Discrete valve: Sub-plate porting

MN3E0
MN4E0
4GA/B
M4GA/B
MN4GA/B
4GA/B (Master)
W4GA/B2
W4GB4
MN3S0
MN4S0
4TB
4L2-4/LMFO
4SA/B0
4SA/B1
4KA/B
<b>4F</b>
PV5G/CMF
PV5/CMF
3MA/B0
3PA/B
P/M/B
NP/NAP/NVP
4F*0E
HMV
HSV
2QV
3QV
SKH
PCD/FS/FD
Ending

## Dimensions

### 4F410

● 2-position single solenoid: DIN terminal box

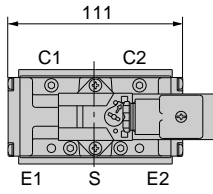

### 4F420

● 2-position double solenoid: DIN terminal box

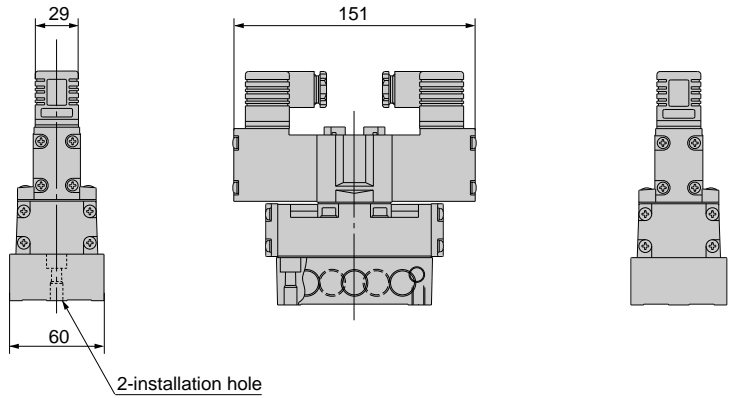
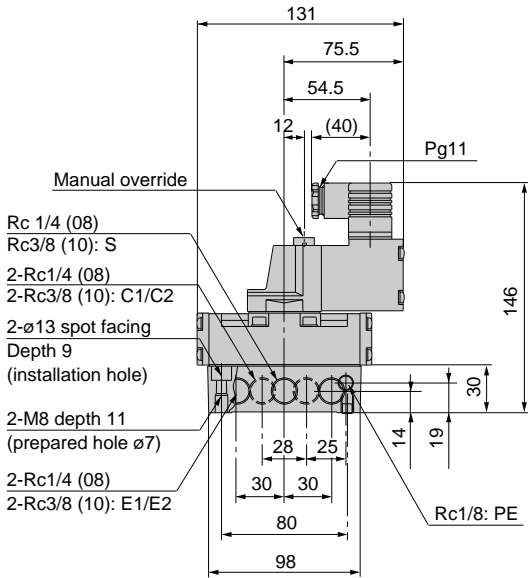
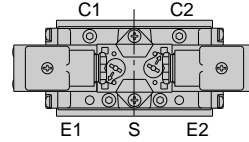

### 4F4<sup>3</sup>/<sub>5</sub>0

● 3-position: DIN terminal box

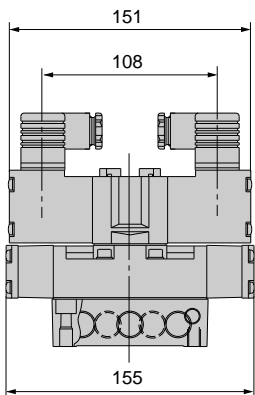
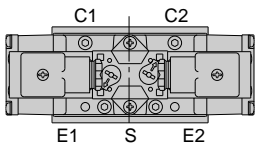

● Mounting bracket: (P)

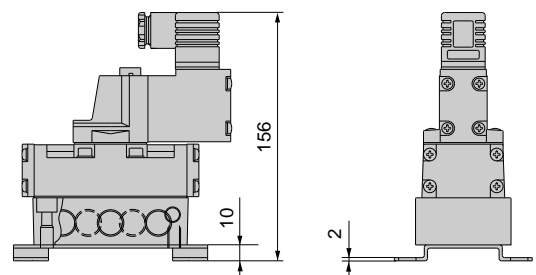
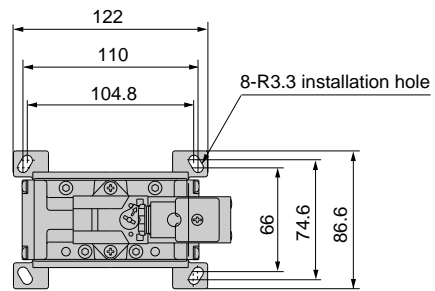

\* Refer to page 954 for a check valve.

### Dimensions

⌚ 2-position single solenoid

⌚ 2-position double solenoid, 3-position  
\* The drawing shows 2-position double solenoid.

● DIN terminal box with indicator light: (L)

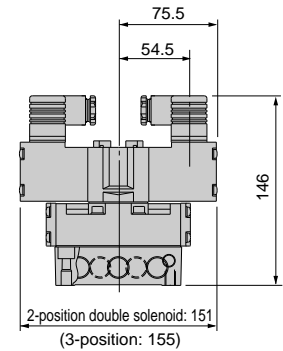
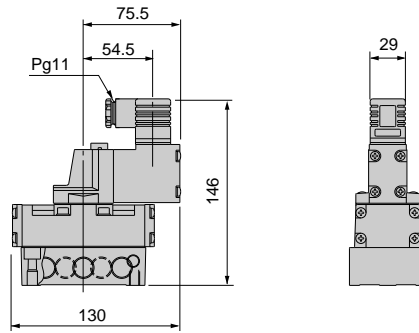

● Grommet lead wire: (E)

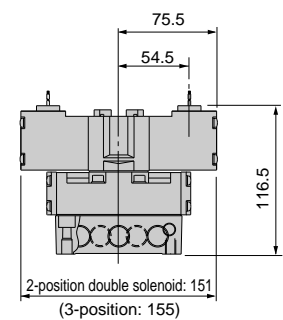
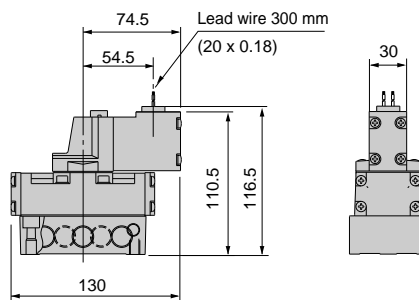

● Conduit lead wire: (E1/E2)

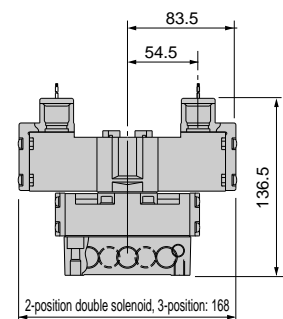
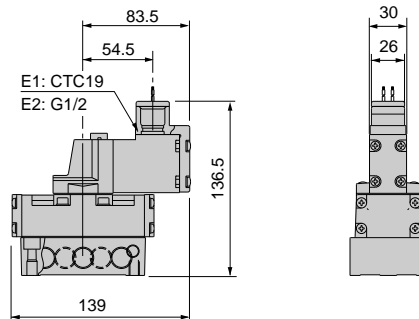

● Round terminal box: (B1/B/BL)

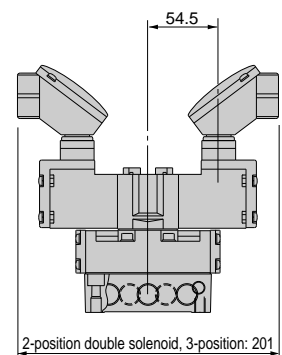
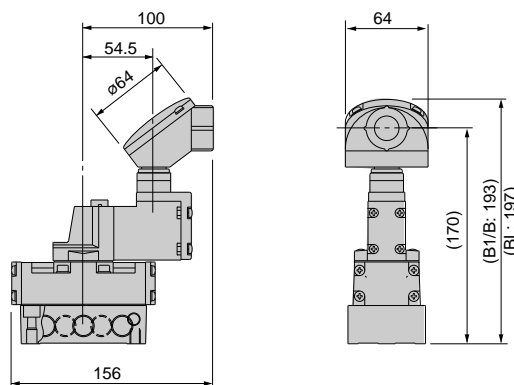

● External pilot port: (K)

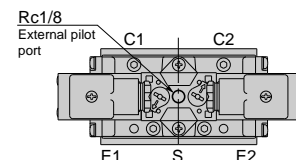
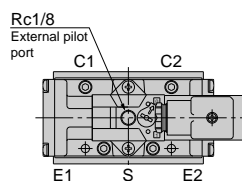

MN3E0
MN4E0
4GA/B
M4GA/B
MN4GA/B
4GA/B (Master)
W4GA/B2
W4GB4
MN3S0
MN4S0
4TB
4L2-4/LMF0
4SA/B0
4SA/B1
4KA/B
<b>4F</b>
PV5G/CMF
PV5/CMF
3MA/B0
3PA/B
P/M/B
NP/NAP/NVP
4F*OE
HMV
HSV
2QV
3QV
SKH
PCD/FS/FD
Ending

Discrete 5 port pilot operated valve

# 4F5 Series

Discrete valve: Sub-plate porting

MN3E0
MN4E0
4GA/B
M4GA/B
MN4GA/B
4GA/B (Master)
W4GA/B2
W4GB4
MN3S0
MN4S0
4TB
4L2-4/LMFO
4SA/B0
4SA/B1
4KA/B
<b>4F</b>
PV5G/CMF
PV5/CMF
3MA/B0
3PA/B
P/MB
NP/NAP/NVP
4F*0E
HMV
HSV
2QV
3QV
SKH
PCD/FS/FD
Ending

## Dimensions

### 4F510



● 2-position single solenoid: DIN terminal box

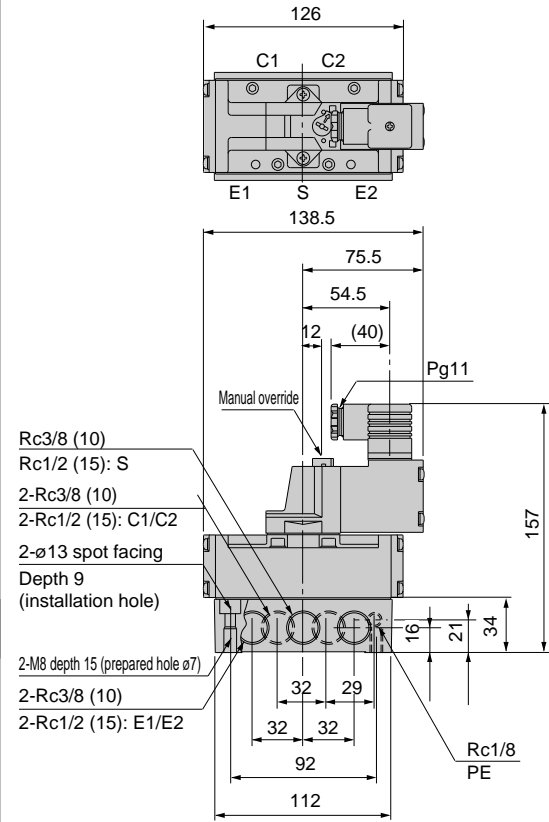

### 4F520



● 2-position double solenoid: DIN terminal box

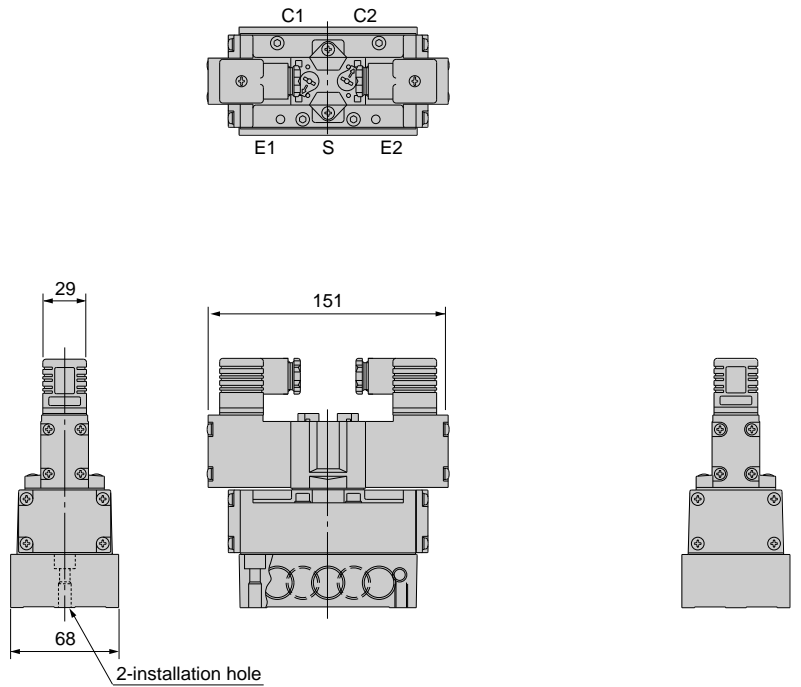

### 4F5 4/5 0



● 3-position: DIN terminal box

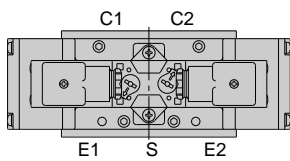

● Mounting bracket: (P)

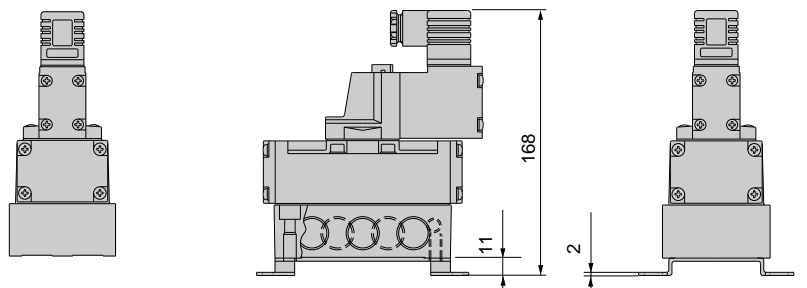
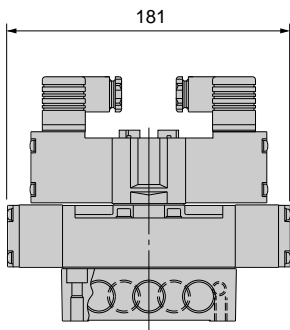
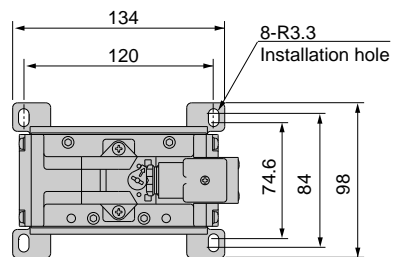

\* Refer to page 954 for a check valve.

### Dimensions

- DIN terminal box with indicator light: (L)

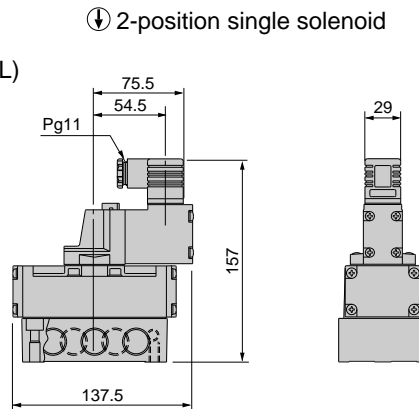

- ⬇ 2-position double solenoid, 3-position
- \* The drawing shows 2-position double solenoid.

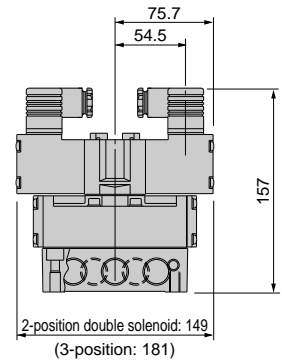

- Grommet lead wire: (E)

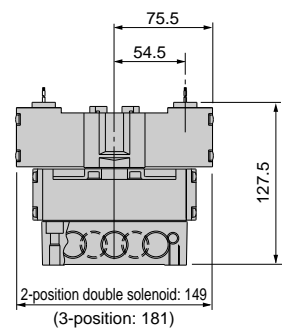
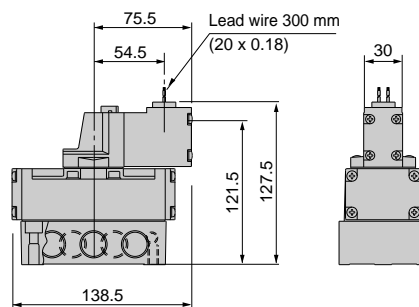

- Conduit lead wire: (E1/E2)

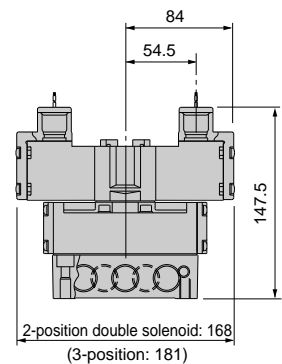
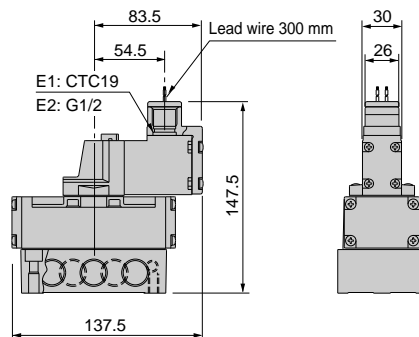

- Round terminal box: (B1/B/BL)

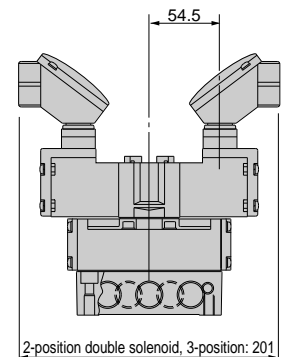
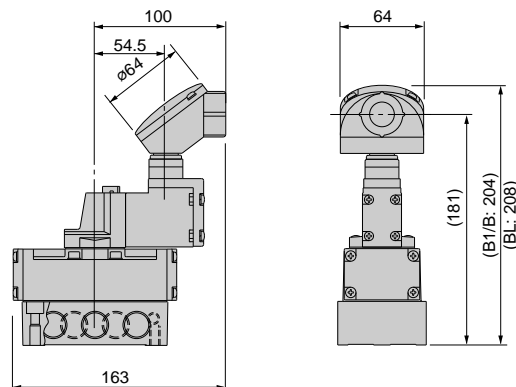

- External pilot port: (K)

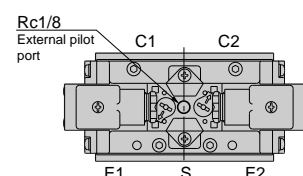
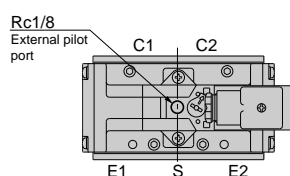

MN3E0
MN4E0
4GA/B
M4GA/B
MN4GA/B
4GA/B (Master)
W4GA/B2
W4GB4
MN3S0
MN4S0
4TB
4L2-4/LMF0
4SA/B0
4SA/B1
4KA/B
<b>4F</b>
PV5G/CMF
PV5/CMF
3MA/B0
3PA/B
P/M/B
NP/NAP/NVP
4F*OE
HMV
HSV
2QV
3QV
SKH
PCD/FS/FD
Ending

Discrete 5 port pilot operated valve

# 4F6 Series

## Discrete valve: Sub-plate porting

### Dimensions

#### 4F610



● 2-position single solenoid: DIN terminal box

#### 4F620



● 2-position double solenoid: DIN terminal box

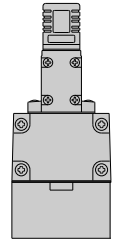
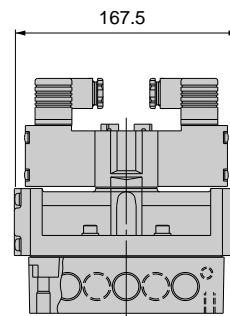
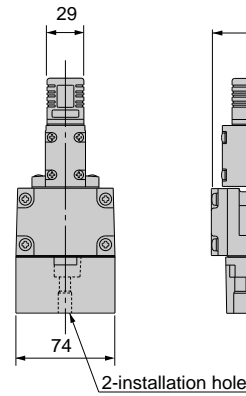
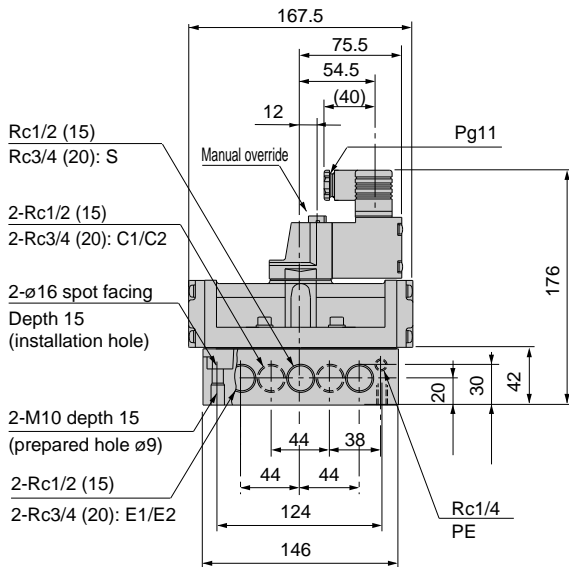
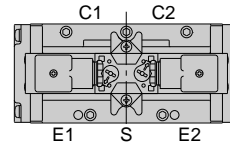
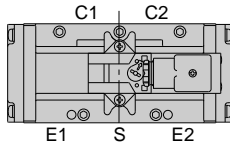

#### 4F6 3/5 0



● 3-position: DIN terminal box

● Mounting bracket: (P)

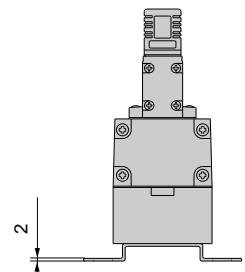
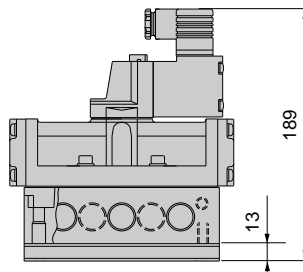
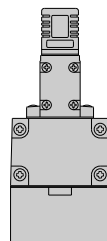
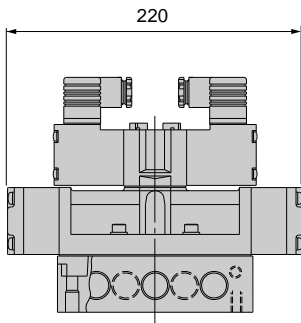
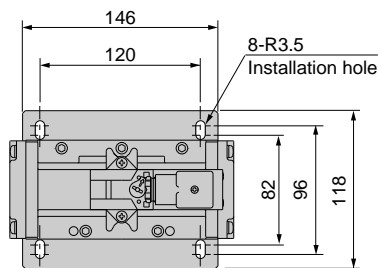
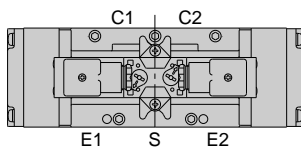

\* Refer to page 954 for a check valve.



### Dimensions

- DIN terminal box with indicator light: (L)

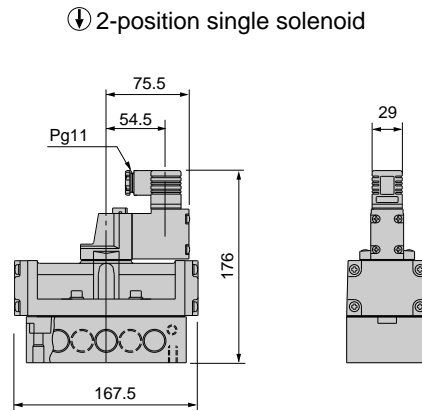

- ⌵ 2-position double solenoid, 3-position  
\* The drawing shows 2-position double solenoid.

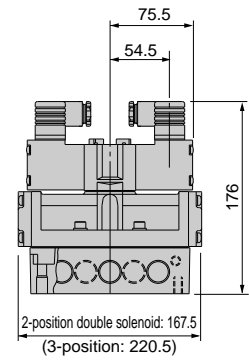

- Grommet lead wire: (E)

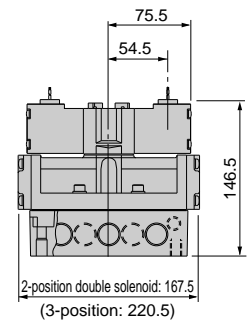
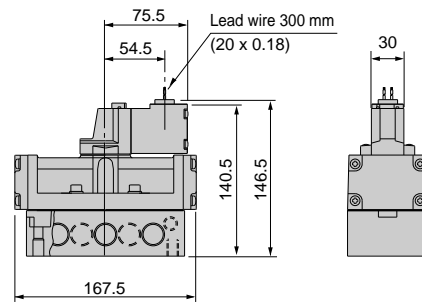

- Conduit lead wire: (E1/E2)

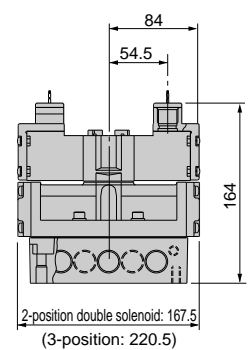
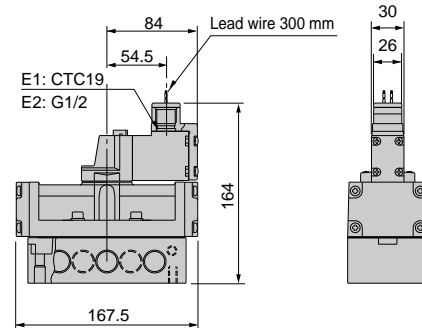

- Round terminal box: (B1/B/BL)

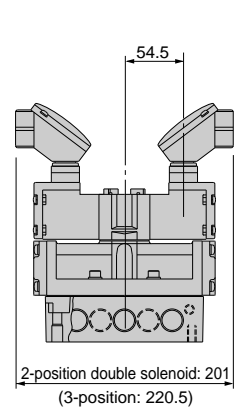
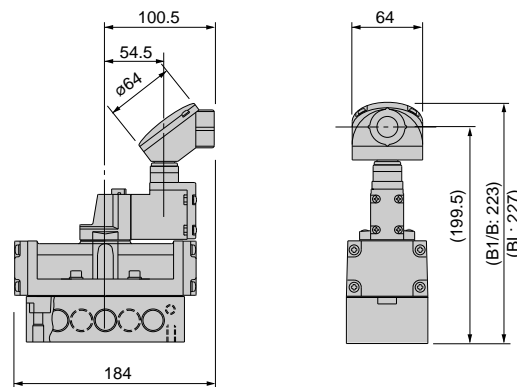

- External pilot port: (K)

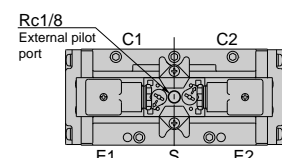
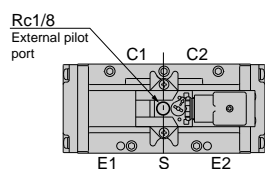

MN3E0
MN4E0
4GA/B
M4GA/B
MN4GA/B
4GA/B (Master)
W4GA/B2
W4GB4
MN3S0
MN4S0
4TB
4L2-4/LMF0
4SA/B0
4SA/B1
4KA/B
<b>4F</b>
PV5G/CMF
PV5/CMF
3MA/B0
3PA/B
P/M/B
NP/NAP/NVP
4F*0E
HMV
HSV
2QV
3QV
SKH
PCD/FS/FD
Ending

Discrete 5 port pilot operated valve

# 4F7 Series

Discrete valve: Sub-plate porting

## Dimensions

### 4F710



● 2-position single solenoid: DIN terminal box

### 4F720



● 2-position double solenoid: DIN terminal box

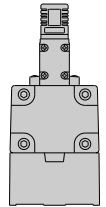
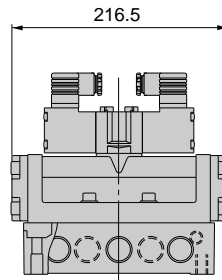
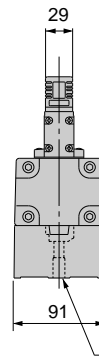
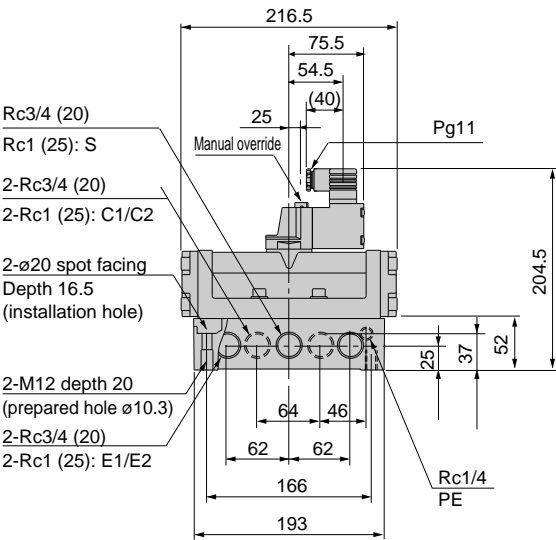
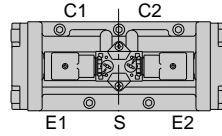
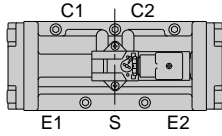

### 4F7<sup>3</sup>/<sub>4</sub>0



● 3-position: DIN terminal box

● Mounting bracket: (P)

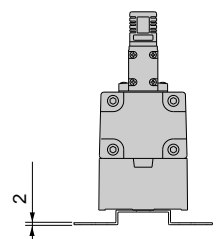
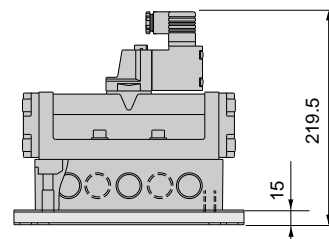
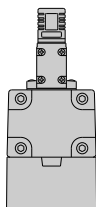
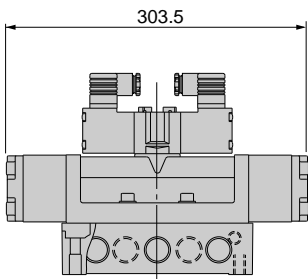
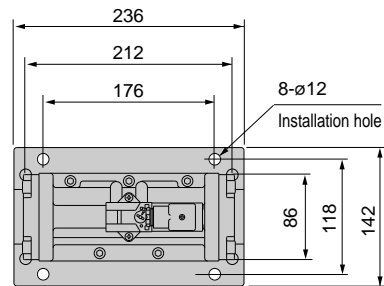
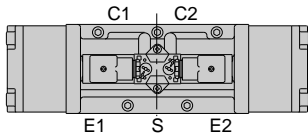

\* Refer to page 954 for a check valve.

### Dimensions

① 2-position single solenoid

② 2-position double solenoid, 3-position  
\* The drawing shows 2-position double solenoid.

● DIN terminal box with indicator light: (L)

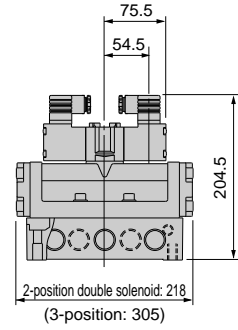
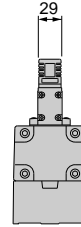
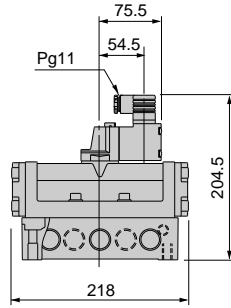

● Grommet lead wire: (E)

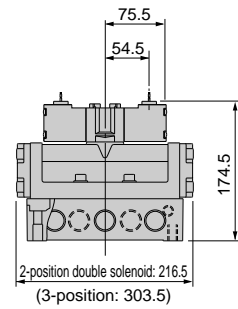
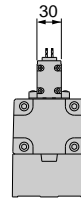
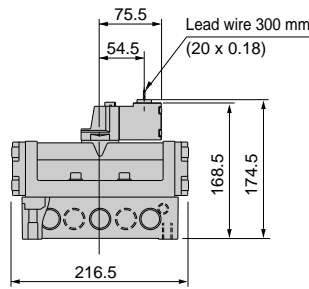

● Conduit lead wire: (E1/E2)

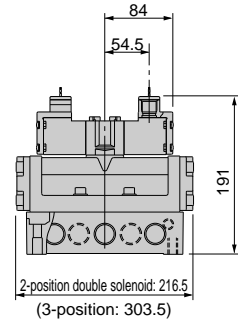
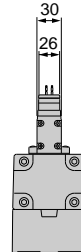
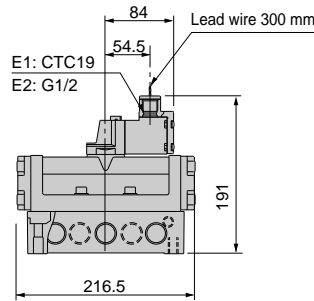

● Round terminal box: (B1/B/BL)

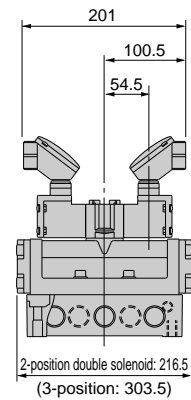
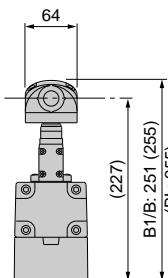
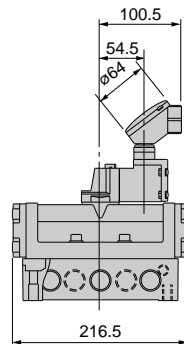

● External pilot port: (K)

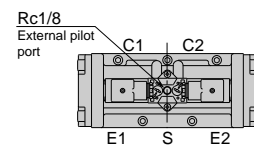
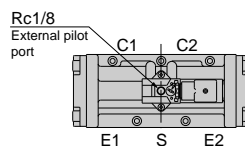

MN3E0
MN4E0
4GA/B
M4GA/B
MN4GA/B
4GA/B (Master)
W4GA/B2
W4GB4
MN3S0
MN4S0
4TB
4L2-4/LMF0
4SA/B0
4SA/B1
4KA/B
<b>4F</b>
PV5G/CMF
PV5/CMF
3MA/B0
3PA/B
P/M/B
NP/NAP/NVP
4F*OE
HMV
HSV
2QV
3QV
SKH
PCD/FS/FD
Ending

Discrete 5 port pilot operated valve

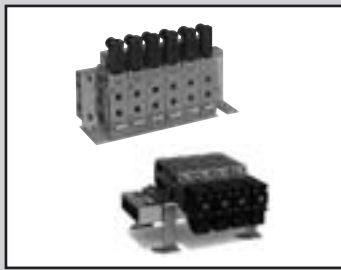

# Individual wiring manifold: Body porting 5 port pilot operated pneumatic valve

## (A)M4F0/1/2/3 Series

● Applicable cylinder bore size:  $\varnothing 16$  to  $\varnothing 100$  mm



Refer to Intro 17 for details.



### JIS symbol

#### ● 5 port valve

##### 2-position single solenoid

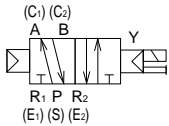

##### 2-position double solenoid

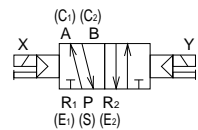

##### 3-position all ports closed

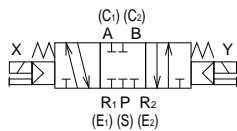

##### 3-position A/B/R connection

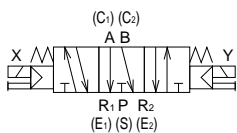

##### 3-position P/A/B connection

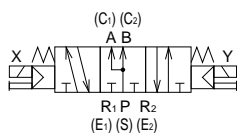

### Common specifications

Descriptions	
Manifold method	Manifold integrated
Manifold type	Common supply / common exhaust
Station number	2 to 10 stations
Valve and operation type	Pilot operated spool valve
Working fluid	Compressed air
Max. working pressure MPa	1.0
Min. working pressure MPa	Refer to the individual specifications below.
Withstanding pressure MPa	1.5
Ambient temperature °C	-10 to 60 (no freezing)
Fluid temperature °C	5 to 60
Lubrication	Not required (when lubricating, use turbine oil ISO VG32.)
Protective structure	Dust proof
Vibration/impact m/s <sup>2</sup>	50 or less / 300 or less
Working environment	Containing corrosive gas is impermissible.

Note 1: Ambient temperature refers to the temperature for storage and installation, and differs from fluid temperature, which applies during operation.

### Electric specifications

Descriptions		(A)4F0 to 1	4F2/3	
Rated voltage	AC	100, 200 (50 / 60Hz)		
	V DC	12, 24		
Rated voltage fluctuation range		±10%		
Starting current	AC	100 V	0.056 / 0.044	0.170 / 0.140
		200 V	0.034 / 0.026	0.090 / 0.070
	A DC	12 V	0.150	0.500
		24 V	0.075	0.250
Holding current	AC	100 V	0.028 / 0.022	0.100 / 0.080
		200 V	0.017 / 0.013	0.050 / 0.040
	A DC	12 V	0.150	0.500
		24 V	0.075	0.250
Power consumption	AC	100 V	1.8 / 1.4	5.0 / 4.0
		200 V	2.1 / 1.6	5.0 / 4.0
	W DC	12 V	1.8	6
		24 V	1.8	6
Heat proof class		B (molded coil)		

Note1: The 100 VAC 50/60 Hz rated voltage can be used at 110 VAC 60 Hz, and 200 VAC 50/60 Hz can be used at 220 VAC 60 Hz.

### Individual specifications

Descriptions		(A)4F0 Note 1	4F1	4F2	4F3		
Min. working pressure MPa	2-position	Single solenoid	0.15	0.15	0.10		
		Double solenoid		0.10			
	3-position	All ports closed	-	0.20	0.15		
		A/B/R connection		-			
Port size Note 2	P (S) port		Rc1/8	Rc1/4	Rc3/8	Rc1/2	
	R <sub>1</sub> (E <sub>1</sub> ), R <sub>2</sub> (E <sub>2</sub> ) port		Rc1/8	Rc1/8	Rc3/8	Rc1/2	
	A (C), B (C) port		M5	Rp1/8	Rp1/8	Rp1/4	Rp1/4
Response time	Note 3	ms	30	30	50	50	

Note 1: (A) is A4F010 for the single type.

Note 2: G and NPT threads are usable for the (A) 4F0, 4F1, 4F2, and 4F3 piping port threads. Contact CKD for details.

Note 3: Response time is the value when supply pressure 0.5 MPa, not lubricated and ON. The value varies depending on pressure and quality of lubricant.

### Flow characteristics

Model no.	Solenoid position		Port size	C (dm <sup>3</sup> / (s·bar))	b
(A) 4F0 Note 2	2-position	Single solenoid	M5	0.61	0.35
		Double solenoid			
	2-position	Single solenoid	Rp1/8	0.74	0.27
		Double solenoid			
4F1	2-position	Single solenoid	Rp1/8	2.0	0.33
		Double solenoid			
	3-position	All ports closed	Rp1/4	1.5	0.31
		A/B/R connection		1.6	0.29
4F2	2-position	Single solenoid	Rp1/4	3.0	0.33
		Double solenoid			
	3-position	All ports closed		2.5	0.43
		A/B/R connection			
4F3	2-position	Single solenoid	Rp1/4	3.9	0.42
		Double solenoid			
	3-position	All ports closed		4.0	0.35
		A/B/R connection			4.5
		P/A/B connection	4.0		0.35
	2-position	Single solenoid	Rp3/8	5.8	0.42
		Double solenoid			
	3-position	All ports closed		4.4	0.42
A/B/R connection		5.1			
	P/A/B connection	4.4	0.42		

Note 1: Effective sectional area S and sonic conductance C are converted as  $S \doteq 5.0 \times C$ .

Note 2: (A) is A4F010 for the single type.

### Copper and PTFE free

● Copper and PTFE material not used for flow path

\*\* - Voltage - **P6**

(4F0 not available)

MN3E0  
MN4E0

4GA/B

M4GA/B

MN4GA/B

4GA/B  
(Master)

W4GA/B2

W4GB4

MN3S0  
MN4S0

4TB

4L2-4/  
LMF0

4SA/B0

4SA/B1

4KA/B

**4F**

PV5G/  
CMF

PV5/  
CMF

3MA/B0

3PA/B

P/M/B

NP/NAP/  
NVP

4F\*0E

HMV  
HSV

2QV  
3QV

SKH

PCD/  
FS/FD

Ending

Individual wiring manifold  
5 port pilot operated valve

# (A)M4F0 to 3 Series

## Individual wiring manifold: Body porting

### Individual wiring manifold: How to order body porting

● Discrete solenoid valve for manifold

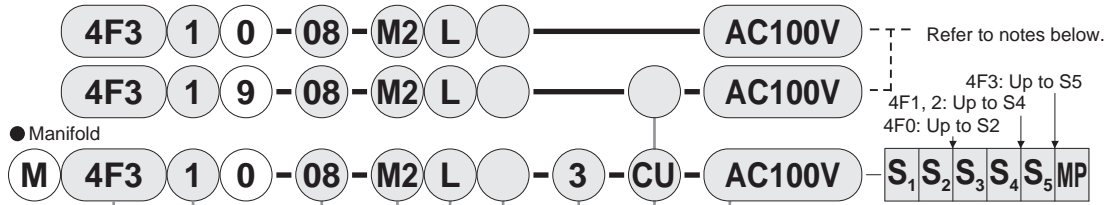

\* Fill out "Manifold specification sheet" (page 956 to 957).

● Manifold

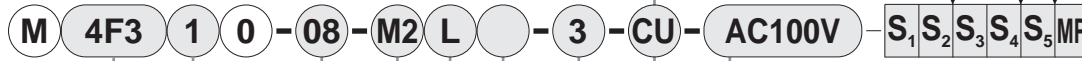

Indicate the quantity and display position of each valve function for the mixed manifold. Refer to page 922.

A Model no.

4	4	4	4
F	F	F	F
0	1	2	3

Symbol	Descriptions	A Model no.			
<b>B Solenoid position</b>					
1	2-position single solenoid	●	●	●	●
2	2-position double solenoid	●	●	●	●
3	3-position all ports closed			●	●
4	3-position A/B/R connection			●	●
5	3-position P/A/B connection				●
8	Mix manifold	●	●	●	●
<b>C Port size</b>					
M5	M5	●			
06	Rp1/8		●		
08	Rp1/4			●	●
10	Rp3/8				●
<b>D Manual override</b>					
M1	Locking	●	●		
Blank	Locking			●	●
Blank	Non-locking	●	●		
M2	Non-locking			●	●
M3	Locking with manual lever			●	●
M4	Non-locking with dust proof cover	●	●		
M6	Non-locking upward	●	●		
R	Manual override position change	●	●	●	●
<b>E Electric connection</b>					
Refer to the next page for wire connections.					
<b>F Other options</b>					
Blank	No option	●	●	●	●
S	Surge suppressor (variable resistor) attached	●	●	●	●
N	Plug attached (3 port valve)	●	●	●	●
NC	3 way valve with plug assembly (C1: A. E1: R1)	●	●	●	●
NO	3 way valve with plug assembly (C2: B. E2: R2)	●	●	●	●
<b>G Station number</b>					
2	2 stations				
to	to	●	●	●	●
10	10 stations				
<b>H Exhaust mounting method</b>					
CL	Common exhaust / L bracket (2-position single solenoid)	●	●	●	●
CU	Common exhaust / U bracket	●	●	●	●
IL	Individual exhaust / L bracket (2-position single solenoid)	●	●	●	●
IU	Individual exhaust / U shaped bracket	●	●	●	●
C	Common exhaust			●	●
I	Individual exhaust			●	●
<b>I Voltage</b>					
AC100V	100 VAC 50/60Hz	●	●	●	●
AC200V	200 VAC 50/60Hz	●	●	●	●
DC12V	12 VDC	●	●	●	●
DC24V	24 VDC	●	●	●	●
AC110V	110 VAC 50/60Hz	●	●	●	●
AC220V	220 VAC 50/60Hz	●	●	●	●

### Note on model no. selection

Use the discrete solenoid valve for manifolds as shown below based on the model.

■ For 4F0 to 4F1



When used as repair parts, purchase the optional gasket kit based on the model below.

- M4F0-GASKET-KIT
- M4F1-GASKET-KIT
- M4F1-I-GASKET-KIT

■ For 4F2/4F3

For exhaust mounting method CL, CU, IL, IU



When used as repair parts, purchase the optional gasket kit based on the model below.

- M4F2-GASKET-KIT
- M4F3-GASKET-KIT

For exhaust mounting method C, I



(If C is selected for item "H", indicate no symbol, and if I is selected, indicate "I".)

The gasket kit is included.

Note 1: When selecting the DIN terminal box for the lock type with a manual lever, the terminal box must face outward during use.

### <Example of model number>

#### M4F340-08-M2ES-5-C-AC100V

- A Model: M4F3
- B Solenoid position : 3-position A/B/R connection
- C Port size : Rp1/4
- D Manual override : Non-locking
- E Electric connection : Grommet lead wire
- F Other options : Surge suppressor attached
- G Station number : 5 stations
- H Exhaust method : Common exhaust
- I Voltage : 100 VAC

### (Electric connection list)

A Model no.			
4	4	4	4
F	F	F	F
0	1	2	3

E Electric connection			
<b>Small terminal box</b>			
<b>B</b>	No lead wire	●	
<b>Blank</b>	No lead wire		●
<b>L</b>	No lead wire with light Note 2	●	●
<b>L2</b>	Lead wire length (300 mm) with light Note 2	●	●
<b>DIN terminal box</b>			
<b>Blank</b>	DIN terminal box (Pg11)		● ●
<b>L</b>	DIN terminal box (Pg11) with light Note 2		● ●
<b>F</b>	DIN terminal box (G1/2)		● ●
<b>C-connector (lead wire lateral)</b>			
<b>C</b>	Lead wire length (300 mm)	● ●	
<b>C00</b>	Lead wire length (500 mm)	● ●	
<b>C01</b>	Lead wire length (1000 mm)	● ●	
<b>C02</b>	Lead wire length (2000 mm)	● ●	
<b>C03</b>	Lead wire length (3000 mm)	● ●	
<b>C1</b>	No lead wire	● ●	
<b>C2</b>	Lead wire length (300 mm) with surge suppressor / light	● ●	
<b>C20</b>	Lead wire length (500 mm) with surge suppressor / light	● ●	
<b>C21</b>	Lead wire length (1000 mm) with surge suppressor / light	● ●	
<b>C22</b>	Lead wire length (2000 mm) with surge suppressor / light	● ●	
<b>C23</b>	Lead wire length (3000 mm) with surge suppressor / light	● ●	
<b>C3</b>	No lead wire with surge suppressor / light	● ●	
<b>D-connector (lead wire upward)</b>			
<b>D</b>	Lead wire length (300 mm)	● ●	
<b>D00</b>	Lead wire length (500 mm)	● ●	
<b>D01</b>	Lead wire length (1000 mm)	● ●	
<b>D02</b>	Lead wire length (2000 mm)	● ●	
<b>D03</b>	Lead wire length (3000 mm)	● ●	
<b>D1</b>	No lead wire	● ●	
<b>D2</b>	Lead wire length (300 mm) with surge suppressor / light	● ●	
<b>D20</b>	Lead wire length (500 mm) with surge suppressor / light	● ●	
<b>D21</b>	Lead wire length (1000 mm) with surge suppressor / light	● ●	
<b>D22</b>	Lead wire length (2000 mm) with surge suppressor / light	● ●	
<b>D23</b>	Lead wire length (3000 mm) with surge suppressor / light	● ●	
<b>D3</b>	No lead wire with surge suppressor / light	● ●	
<b>Grommet lead wire</b>			
<b>Blank</b>	Grommet lead wire	●	
<b>E</b>	Grommet lead wire		● ● ●
<b>E1</b>	Conduit lead wire (CTC19)		● ● ●
<b>E2</b>	Conduit lead wire (G1/2)		● ●

Note 2: The L and L2 DC type have a built-in surge suppressor.  
(Refer to page 887 for the circuit drawings with light and surge suppressor.)

MN3E0
MN4E0
4GA/B
M4GA/B
MN4GA/B
4GA/B (Master)
W4GA/B2
W4GB4
MN3S0
MN4S0
4TB
4L2-4/LMF0
4SA/B0
4SA/B1
4KA/B
<b>4F</b>
PV5G/CMF
PV5/CMF
3MA/B0
3PA/B
P/M/B
NP/NAP/NVP
4F*0E
HMV
HSV
2QV
3QV
SKH
PCD/FS/FD
Ending

Individual wiring manifold  
5 port pilot operated valve

# (A)M4F0 to 3 Series

## Individual wiring manifold: Body porting

### How to order masking plate kit (gasket attached)

● M4F0 to 2

**M4F0 - MP-KIT**

Model no.

Model no.
M4F0
M4F1
M4F2

● M4F3

**M4F3 - 08 - MP-KIT**

Model no.

Port size

Port size	
08	Rp1/8
10	Rp3/4

### How to order mix manifold

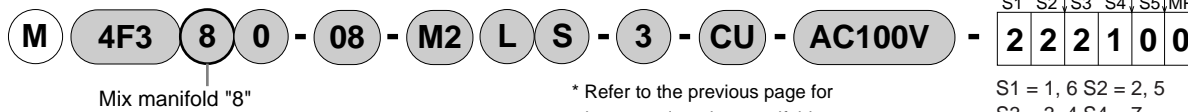

### How to order Mixed Manifold Models

- (1) Indicate the quantity for each function (solenoid position) at the end of the model. Functions and symbols are indicated below.

Example: 2-position single solenoid → S1

Symbol	Function (solenoid position)
S1	2-position single solenoid
S2	2-position double solenoid
S3	3-position all ports closed
S4	3-position A/B/R connection
S5	3-position P/A/B connection
MP	Masking plate

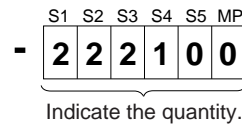

- (2) Indicate the function (solenoid position) and layout position in the Remarks field.

Changeover position symbol: ○, ○th station. (Refer to the dimension drawings (pages 924 to 944) for details on counting stations.)

Example: S1 = 1, 6 (1st, 6th station are 2-position single solenoid.)

### <Example of model number>

For 7 stations

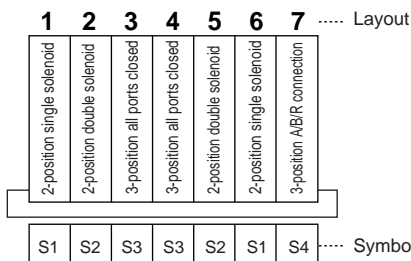

- 2-position single solenoid (S1) : 2 piece (1st and 6th station)  
 2-position double solenoid (S2) : 2 piece (2nd and 5th station)  
 3-position all ports closed (S3) : 2 piece (3rd and 4th station)  
 3-position A/B/R connection (S4) : 1 piece (7th station)

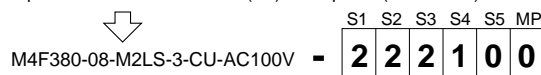

S1 = 1, 6 S2 = 2, 5 S3 = 3, 4 S4 = 7



MEMO

	MN3E0 MN4E0
	4GA/B
	M4GA/B
	MN4GA/B
	4GA/B (Master)
	W4GA/B2
	W4GB4
	MN3S0 MN4S0
	4TB
	4L2-4/ LMF0
	4SA/B0
	4SA/B1
	4KA/B
	<b>4F</b>
	PV5G/ CMF
	PV5/ CMF
	3MA/B0
	3PA/B
	P/M/B
	NP/NAP/ NVP
	4F*0E
	HMV HSV
	2QV 3QV
	SKH
	PCD/ FS/FD
	Ending
	Individual wiring manifold
	5 port pilot operated valve

# (A)M4F0 Series

Individual wiring manifold: Body porting

Dimensions



## AM4F010 (only 2-position single solenoid)

● Common exhaust / L bracket: Grommet lead wire (CL)

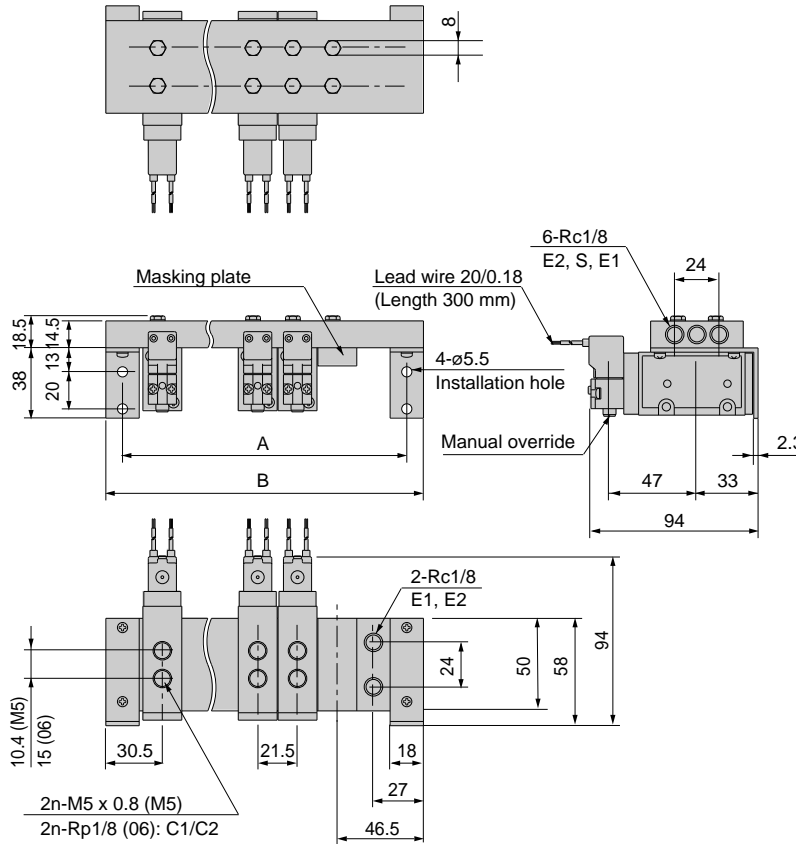

● Individual exhaust / L bracket (IL)

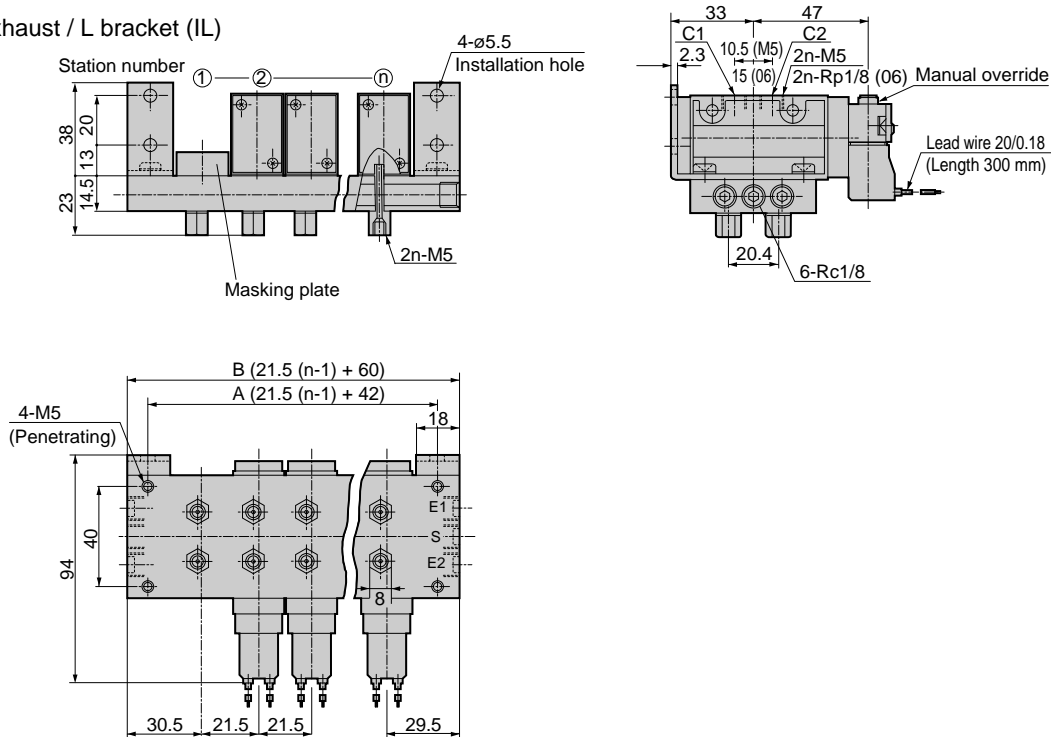

Common exhaust type

Individual exhaust type

Station number	2	3	4	5	6	7	8	9	10	Station number	2	3	4	5	6	7	8	9	10
<b>A</b>	80.5	102	123.5	145	166.5	188	209.5	231	252.5	<b>A</b>	63.5	85	106.5	128	149.5	171	192.5	214	235.5
<b>B</b>	98.5	120	141.5	163	184.5	206	227.5	249	270.5	<b>B</b>	81.5	103	124.5	146	167.5	189	210.5	232	253.5

\* Refer to page 954 for a check valve.

### Dimensions

● Small terminal box: (B)

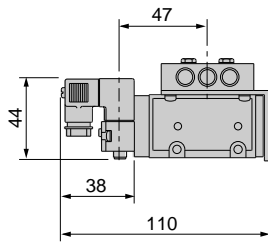

● Small terminal box with light: (L/L2)

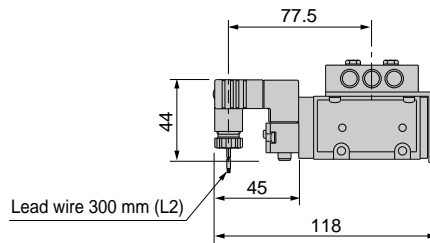

● C-connector: (C, C0\*, C1, C2, C2\*, C3)

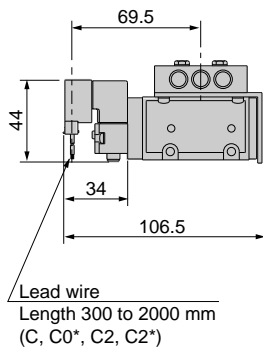

● D-connector: (D, D0\*, D1, D2, D2\*, D3)

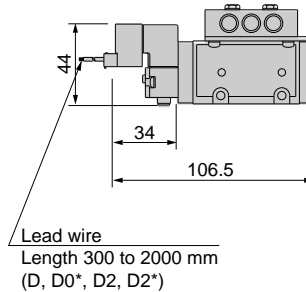

● Manual position change: (R)

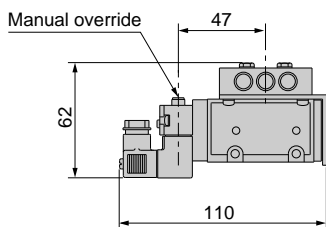

MN3E0
MN4E0
4GA/B
M4GA/B
MN4GA/B
4GA/B (Master)
W4GA/B2
W4GB4
MN3S0
MN4S0
4TB
4L2-4/ LMF0
4SA/B0
4SA/B1
4KA/B
<b>4F</b>
PV5G/ CMF
PV5/ CMF
3MA/B0
3PA/B
P/M/B
NP/NAP/ NVP
4F*0E
HMV
HSV
2QV
3QV
SKH
PCD/ FS/FD
Ending

Individual wiring manifold  
5 port pilot operated valve

# (A)M4F0 Series

Individual wiring manifold: Body porting

Dimensions



## AM4F010/M4F020

● Common exhaust / U bracket: Grommet lead wire (CU)

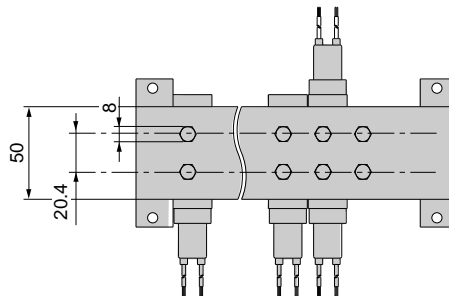
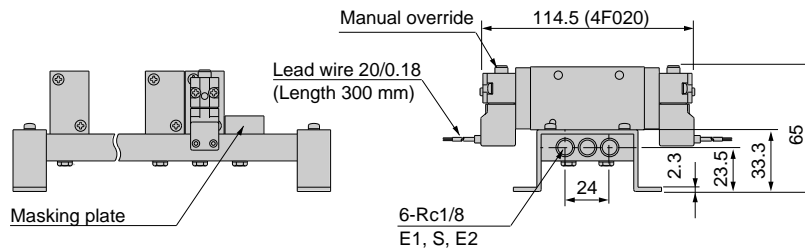
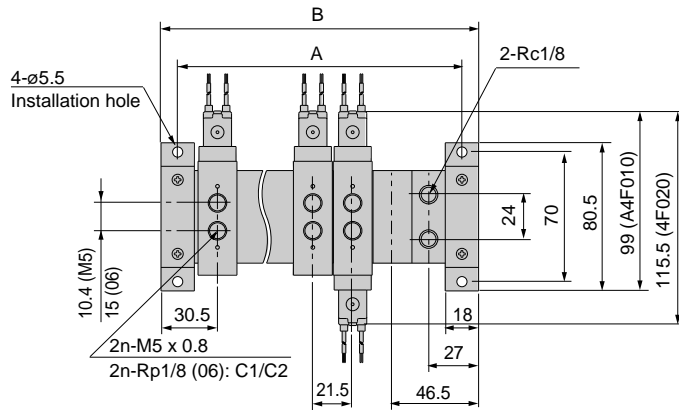

● Individual exhaust / U bracket (IU)

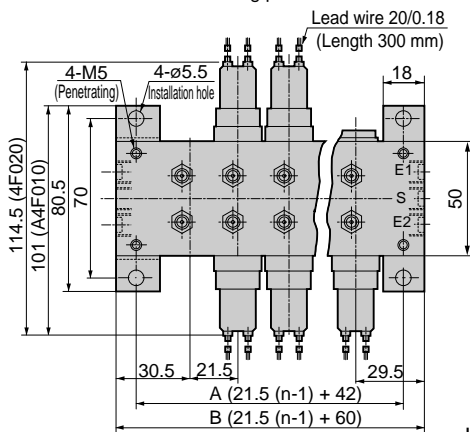
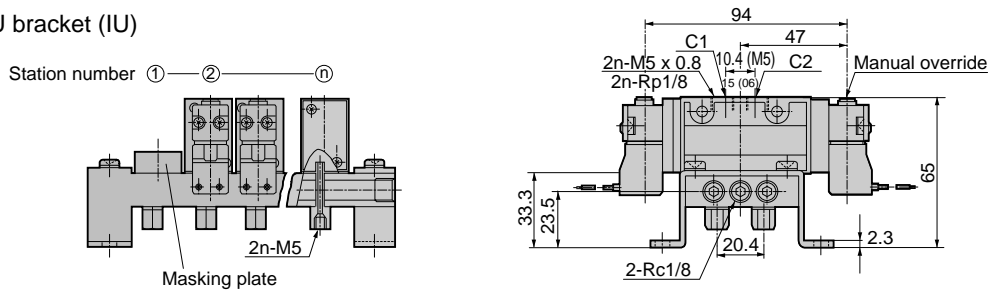

Common exhaust type

Individual exhaust type

Station number	2	3	4	5	6	7	8	9	10	Station number	2	3	4	5	6	7	8	9	10
<b>A</b>	80.5	102	123.5	145	166.5	188	209.5	231	252.5	<b>A</b>	63.5	85	106.5	128	149.5	171	192.5	214	235.5
<b>B</b>	98.5	120	141.5	163	184.5	206	227.5	249	270.5	<b>B</b>	81.5	103	124.5	146	167.5	189	210.5	232	253.5

\* Refer to page 954 for a check valve.

### Dimensions

#### ● Small terminal box: (B)

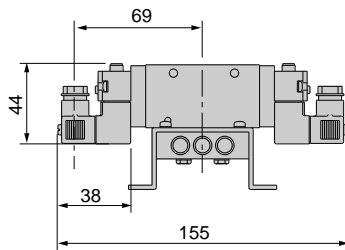

#### ● Small terminal box with light: (L/L2)

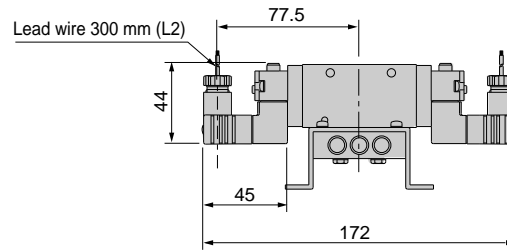

#### ● C-connector: (C, C0\*, C1, C2, C2\*, C3)

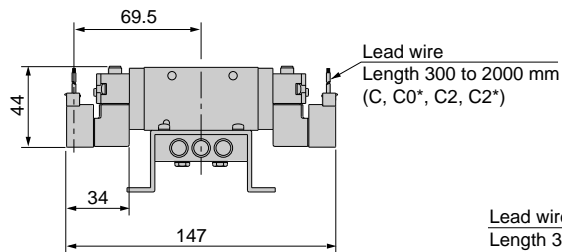

#### ● D-connector: (D, D0\*, D1, D2, D2\*, D3)

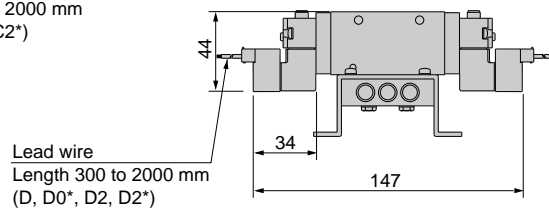

#### ● Manual position change: (R)

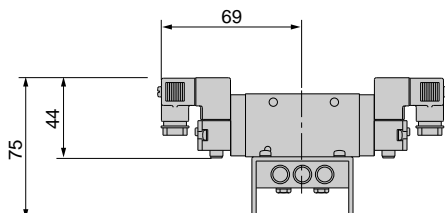

MN3E0
MN4E0
4GA/B
M4GA/B
MN4GA/B
4GA/B (Master)
W4GA/B2
W4GB4
MN3S0
MN4S0
4TB
4L2-4/LMF0
4SA/B0
4SA/B1
4KA/B
<b>4F</b>
PV5G/CMF
PV5/CMF
3MA/B0
3PA/B
P/M/B
NP/NAP/NVP
4F*0E
HMV
HSV
2QV
3QV
SKH
PCD/FS/FD
Ending

Individual wiring manifold  
5 port pilot operated valve

# M4F1 Series

## Individual wiring manifold: Body porting

### Dimensions



### M4F110 (2-position single solenoid)

● Common exhaust / L bracket: Small terminal box (CL)

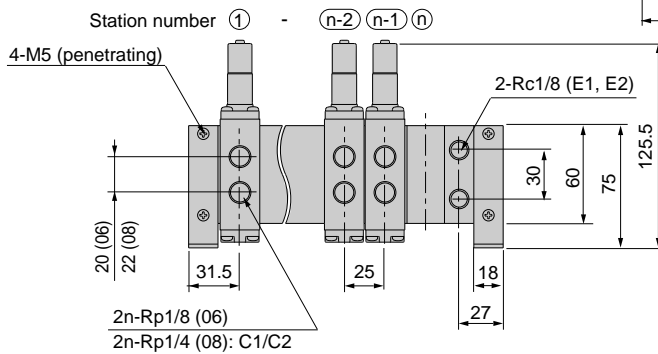
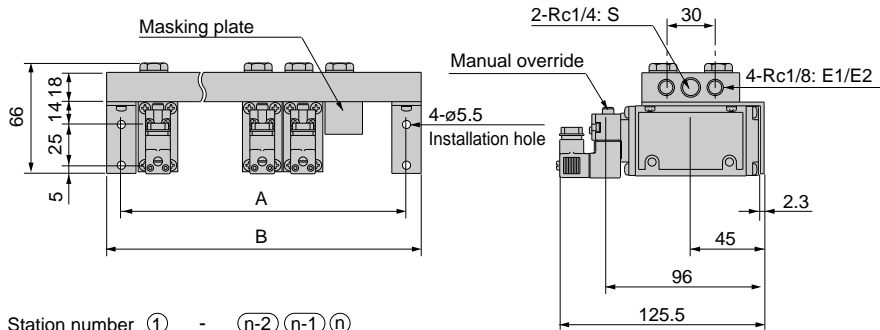
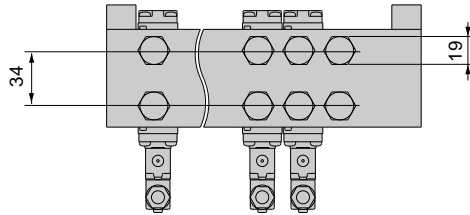

● Individual exhaust / L bracket (IL)

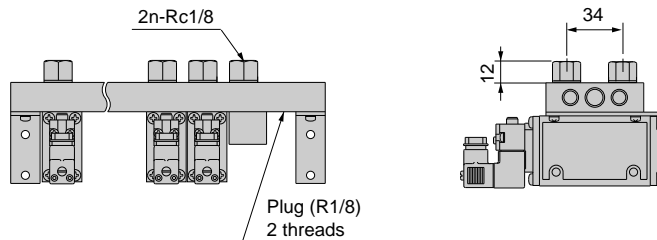

### Common exhaust / individual exhaust type

Station number	2	3	4	5	6	7	8	9	10
<b>A</b>	86	111	136	161	186	211	236	261	286
<b>B</b>	104	129	154	179	204	229	254	279	304

\* Refer to page 954 for a check valve.

### Dimensions

● Grommet lead wire: (E)

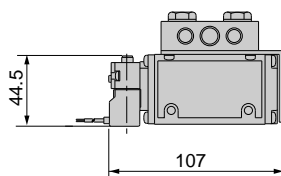

● Small terminal box with light: (L/L2)

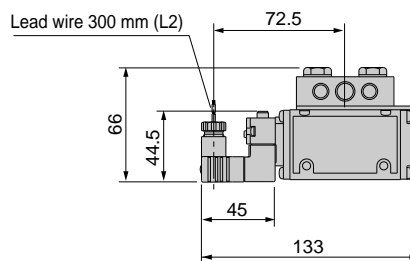

● C-connector: (C, C0\*, C1, C2, C2\*, C3)

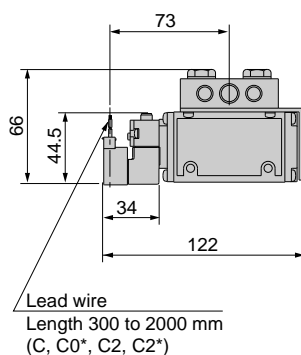

● D-connector: (D, D0\*, D1, D2, D2\*, D3)

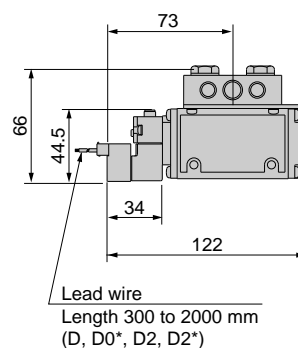

● Manual position change: (R)

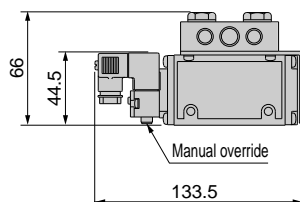

MN3E0
MN4E0
4GA/B
M4GA/B
MN4GA/B
4GA/B (Master)
W4GA/B2
W4GB4
MN3S0
MN4S0
4TB
4L2-4/ LMF0
4SA/B0
4SA/B1
4KA/B
<b>4F</b>
PV5G/ CMF
PV5/ CMF
3MA/B0
3PA/B
P/M/B
NP/NAP/ NVP
4F*0E
HMV
HSV
2QV
3QV
SKH
PCD/ FS/FD
Ending

Individual wiring manifold  
5 port pilot operated valve

# M4F1 Series

## Individual wiring manifold: Body porting

### Dimensions



### M4F1 $\frac{1}{3}$ 0

● Common exhaust / U bracket: Small terminal box (CU)

\* Manual position change (R) type is recommended.

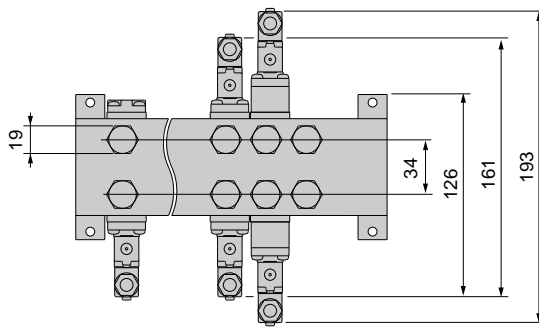
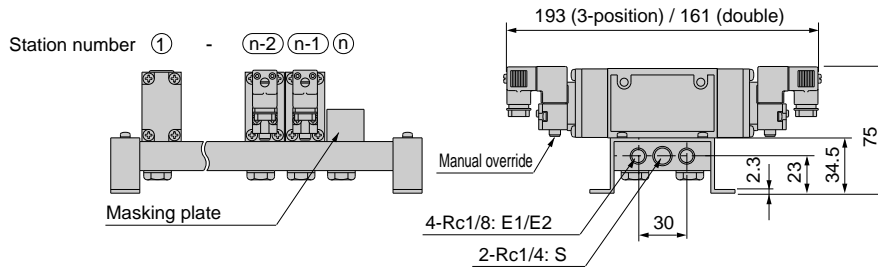
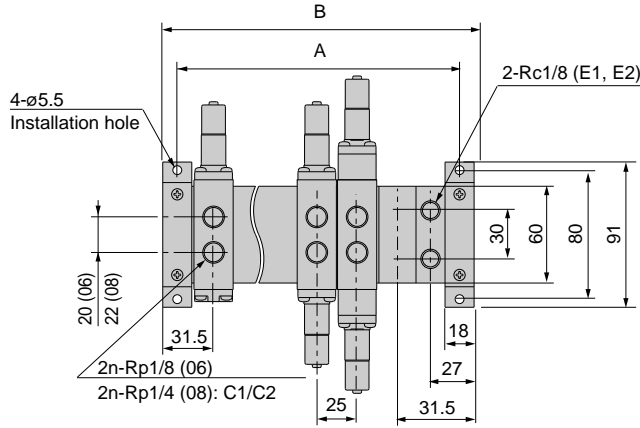

● Individual exhaust / U bracket (IU)

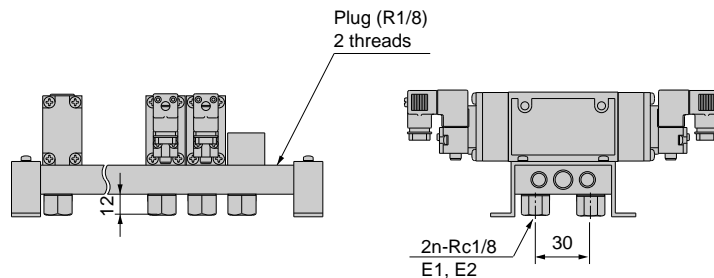

### Common exhaust / individual exhaust type

Station number	2	3	4	5	6	7	8	9	10
<b>A</b>	86	111	136	161	186	211	236	261	286
<b>B</b>	104	129	154	179	204	229	254	279	304

\* Refer to page 954 for a check valve.



### Dimensions

● Grommet lead wire: (E)

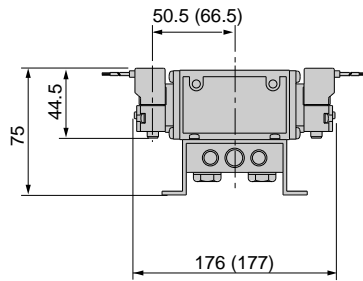

● Small terminal box with light: (L/L2)

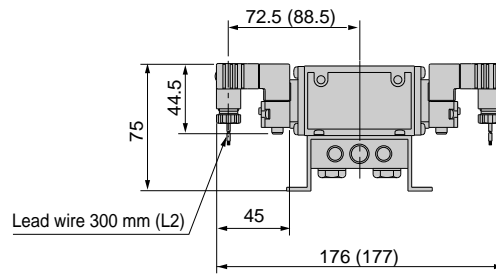

● C-connector: (C, C0\*, C1, C2, C2\*, C3)

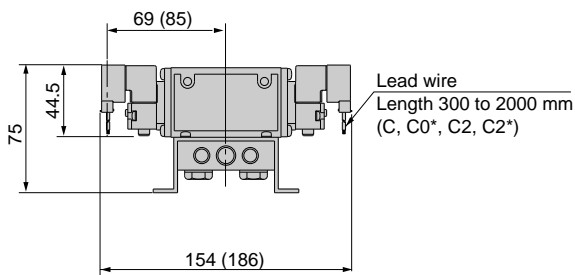

● D-connector: (D, D0\*, D1, D2, D2\*, D3)

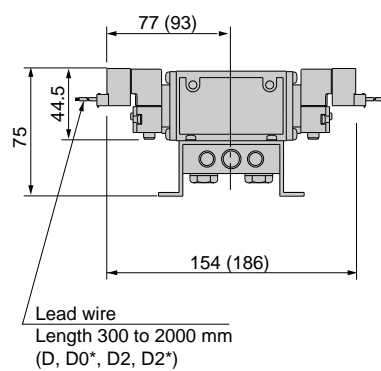

● Manual position change: (R)

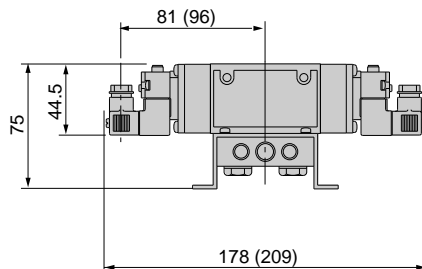

\* Values in ( ) are dimensions of 3-position.

MN3E0
MN4E0
4GA/B
M4GA/B
MN4GA/B
4GA/B (Master)
W4GA/B2
W4GB4
MN3S0
MN4S0
4TB
4L2-4/ LMFO
4SA/B0
4SA/B1
4KA/B
<b>4F</b>
PV5G/ CMF
PV5/ CMF
3MA/B0
3PA/B
P/M/B
NP/NAP/ NVP
4F*0E
HMV
HSV
2QV
3QV
SKH
PCD/ FS/FD
Ending

Individual wiring manifold  
5 port pilot operated valve

# M4F1 Series

Individual wiring manifold: Body porting

Dimensions 

## M4F1\*0

● Individual exhaust (I)

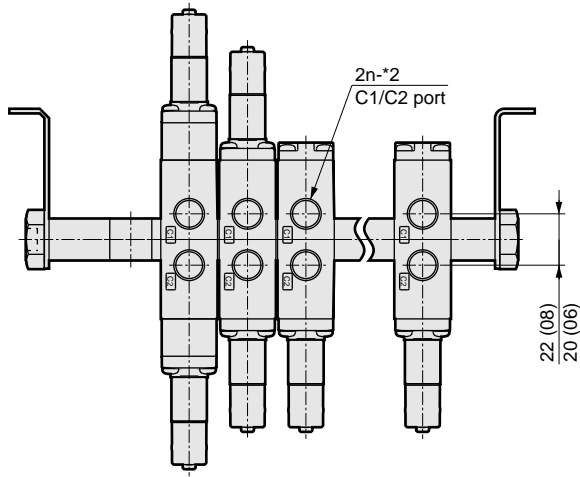

Station number (1) (2) (3) (4) ... (n)

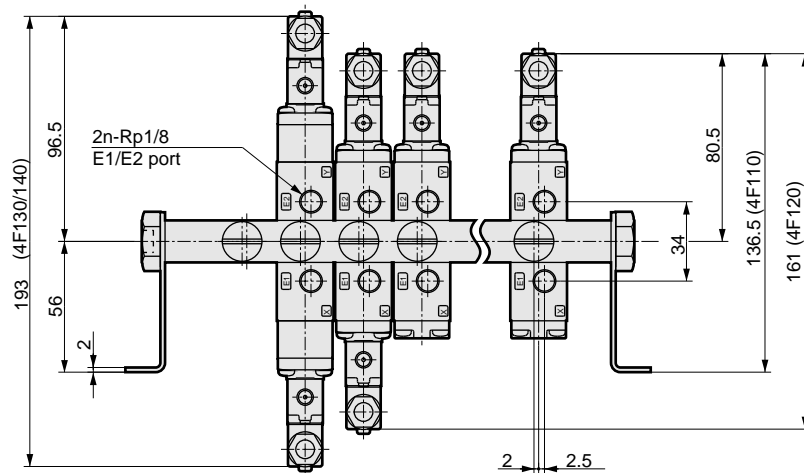
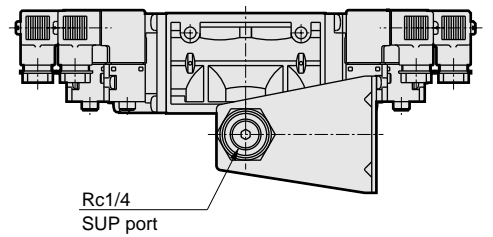
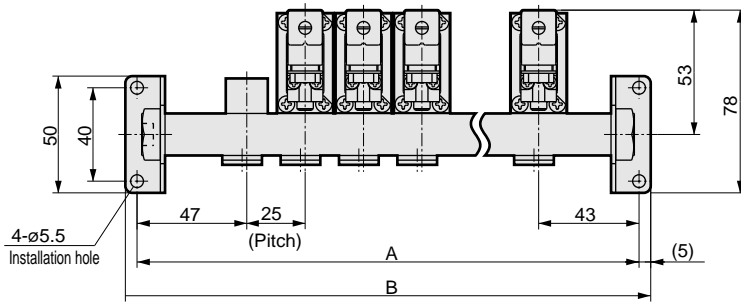

### Individual exhaust type

Station number	2	3	4	5	6	7	8	9	10
A	115	140	165	190	215	240	265	290	315
B	125	150	175	200	225	250	275	300	325

\* Refer to page 954 for a check valve.

### Dimensions

● Small terminal box with light: (L/L2)

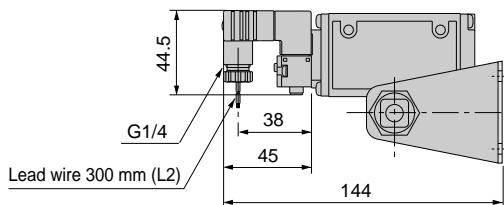

● Grommet lead wire: (E)

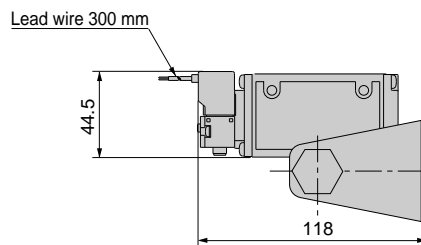

● C-connector: (C, C0\*, C1, C2, C2\*, C3)

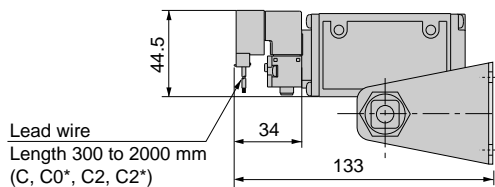

● D-connector: (D, D0\*, D1, D2, D2\*, D3)

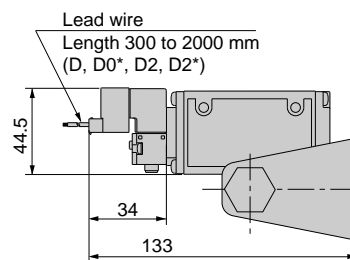

MN3E0
MN4E0
4GA/B
M4GA/B
MN4GA/B
4GA/B (Master)
W4GA/B2
W4GB4
MN3S0
MN4S0
4TB
4L2-4/ LMFO
4SA/B0
4SA/B1
4KA/B
<b>4F</b>
PV5G/ CMF
PV5/ CMF
3MA/B0
3PA/B
P/M/B
NP/NAP/ NVP
4F*0E
HMV
HSV
2QV
3QV
SKH
PCD/ FS/FD
Ending

Individual wiring manifold  
5 port pilot operated valve

# M4F2 Series

Individual wiring manifold: Body porting

Dimensions



## M4F210 (2-position single solenoid)

● Common exhaust / L bracket: Small terminal box (CL)

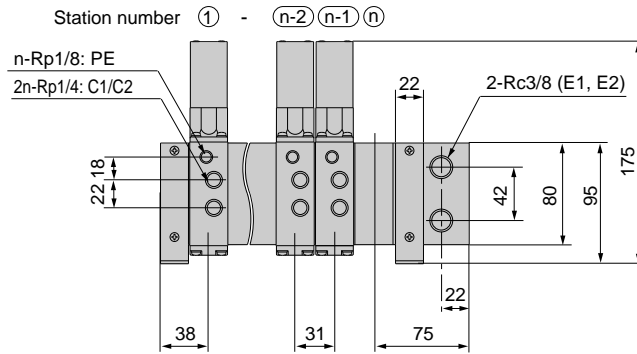
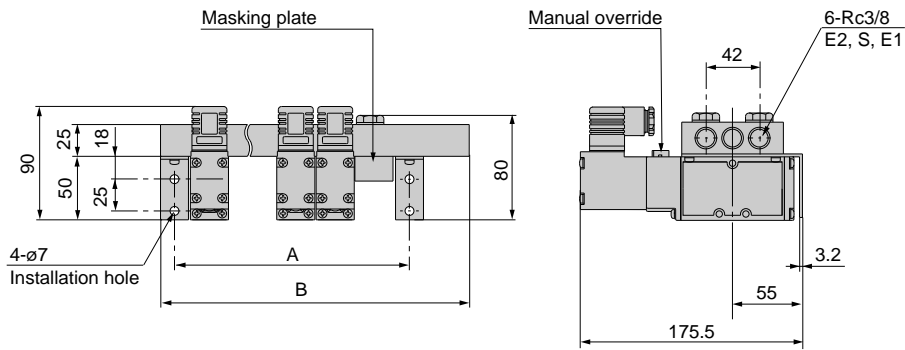
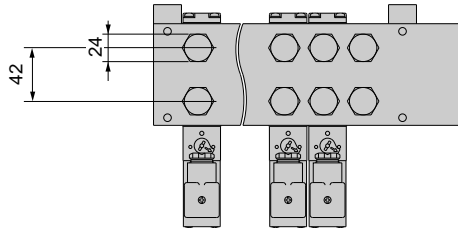

● Individual exhaust / L bracket (IL)

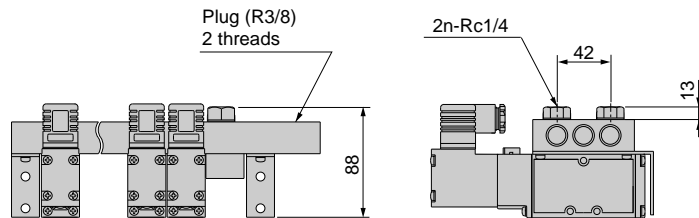

Common exhaust / individual exhaust type

Station number	2	3	4	5	6	7	8	9	10
A	86	117	148	179	210	241	272	303	334
B	144	175	206	237	268	299	330	361	392

\* Refer to page 954 for a check valve.

### Dimensions

● Grommet lead wire: (E)

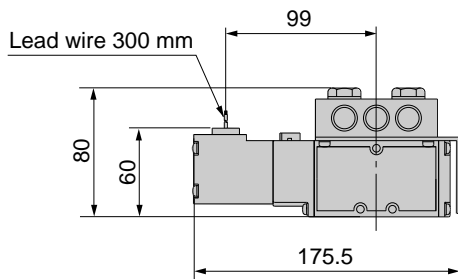

● Conduit lead wire: (E1/E2)

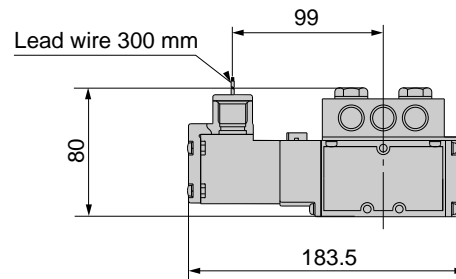

● Manual position change: (R)

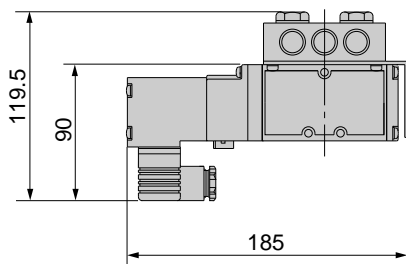

MN3E0
MN4E0
4GA/B
M4GA/B
MN4GA/B
4GA/B (Master)
W4GA/B2
W4GB4
MN3S0
MN4S0
4TB
4L2-4/ LMF0
4SA/B0
4SA/B1
4KA/B
<b>4F</b>
PV5G/ CMF
PV5/ CMF
3MA/B0
3PA/B
P/M/B
NP/NAP/ NVP
4F*0E
HMV
HSV
2QV
3QV
SKH
PCD/ FS/FD
Ending

Individual wiring manifold  
5 port pilot operated valve

# M4F2 Series

## Individual wiring manifold: Body porting

Dimensions



**M4F2**  $\frac{1}{2}$   $\frac{0}{3}$

● Common exhaust / U bracket: Small terminal box (CU)

\* Manual position change (R) type is recommended.

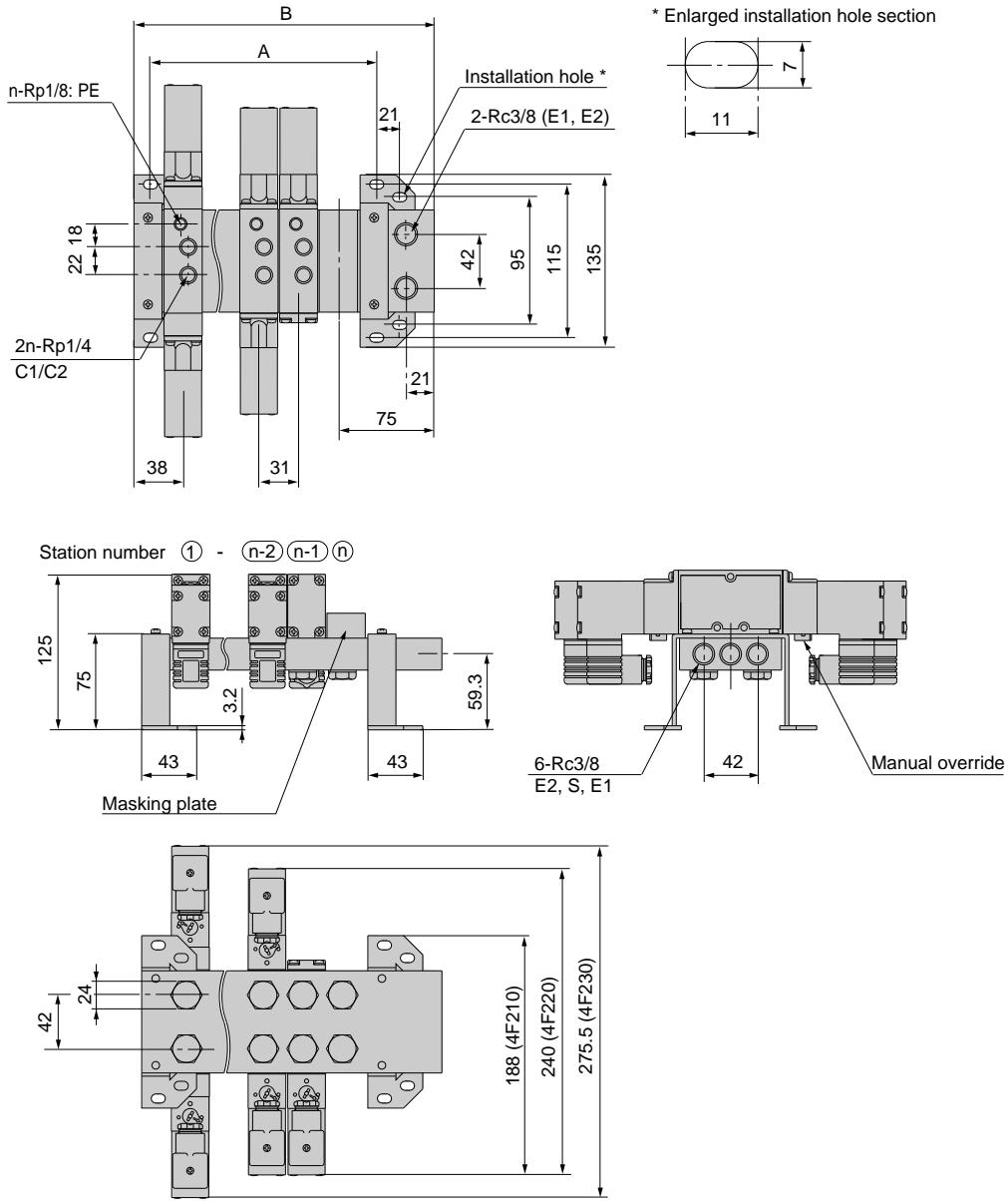

● Individual exhaust / U bracket (IU)

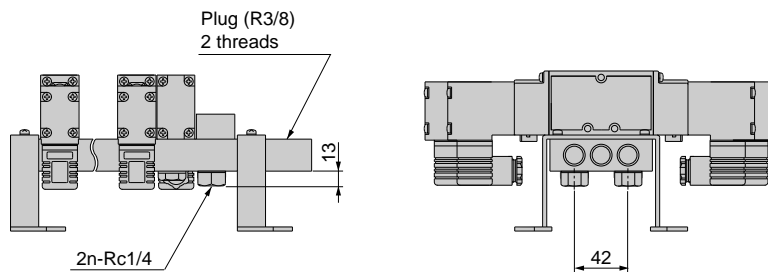

Common exhaust / individual exhaust type

Station number	2	3	4	5	6	7	8	9	10
<b>A</b>	86	117	148	179	210	241	272	303	334
<b>B</b>	144	175	206	237	268	299	330	361	392

\* Refer to page 954 for a check valve.

### Dimensions

● Grommet lead wire: (E)

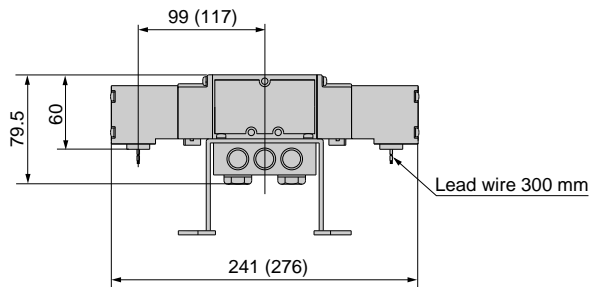

● Conduit lead wire: (E1/E2)

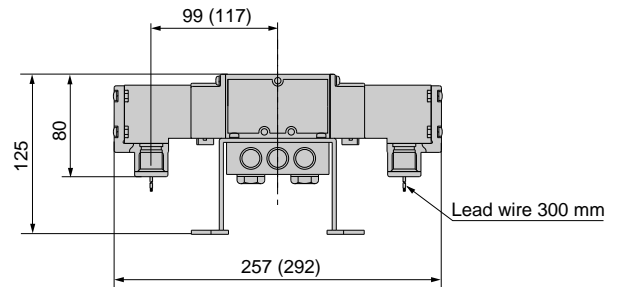

● Manual position change: (R)

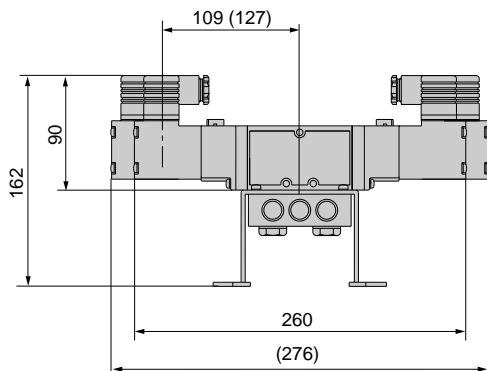

\* Values in ( ) are dimensions of 3-position.

MN3E0
MN4E0
4GA/B
M4GA/B
MN4GA/B
4GA/B (Master)
W4GA/B2
W4GB4
MN3S0
MN4S0
4TB
4L2-4/ LMF0
4SA/B0
4SA/B1
4KA/B
<b>4F</b>
PV5G/ CMF
PV5/ CMF
3MA/B0
3PA/B
P/M/B
NP/NAP/ NVP
4F*0E
HMV
HSV
2QV
3QV
SKH
PCD/ FS/FD
Ending

Individual wiring manifold  
5 port pilot operated valve

# M4F2 Series

## Individual wiring manifold: Body porting

### Dimensions



### M4F2\*0

- Individual exhaust (I)
- Common exhaust (C)

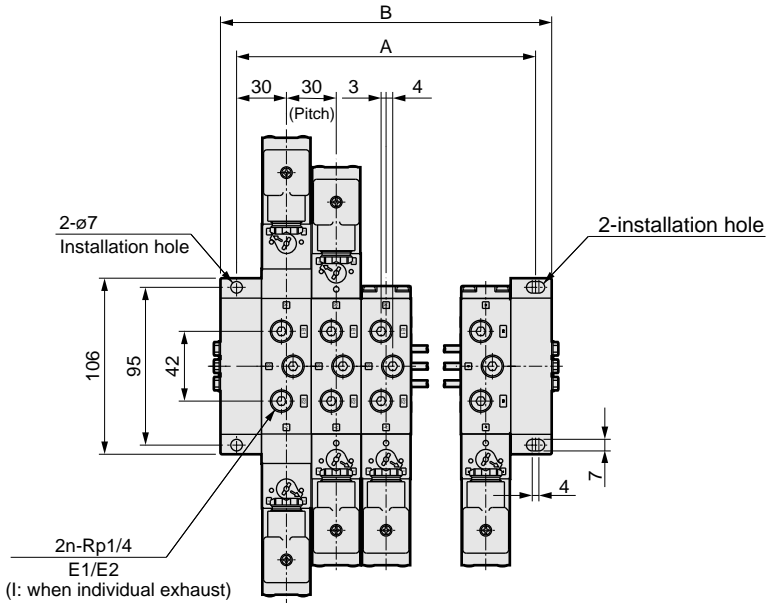

Station number ① ② ③ ... ④

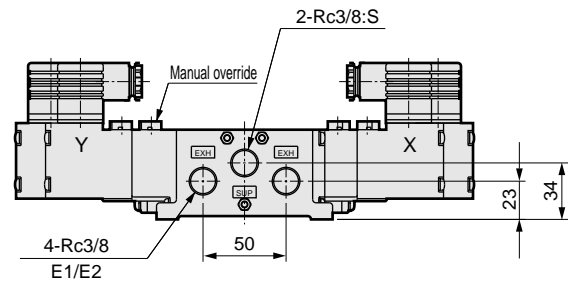
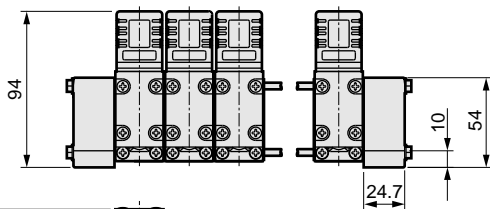

(I: Plug when individual exhaust)

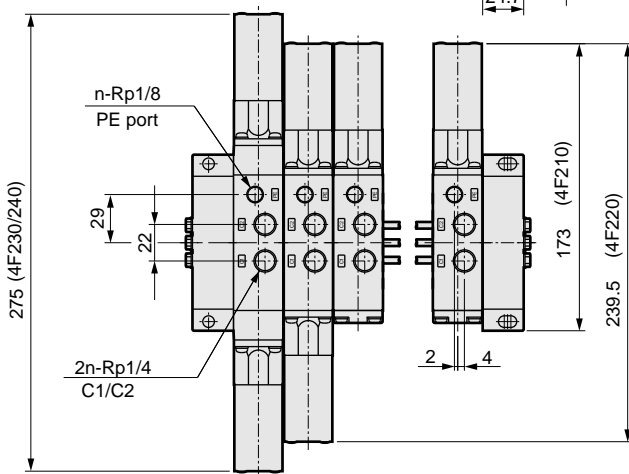

Individual exhaust type  
Common exhaust type

Station number	2	3	4	5	6	7	8	9	10
<b>A</b>	90	120	150	180	210	240	270	300	330
<b>B</b>	109.4	139.4	169.4	199.4	229.4	259.4	289.4	319.4	349.4



### Dimensions

● DIN terminal box with indicator light: (L)

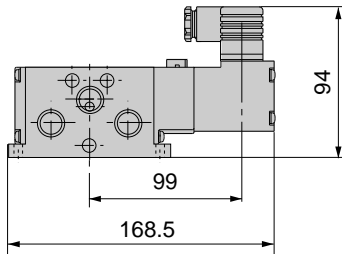

● Grommet lead wire: (E)

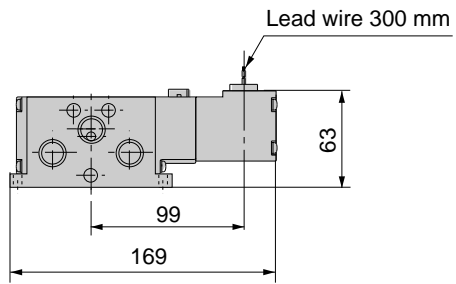

● Conduit lead wire: (E1/E2)

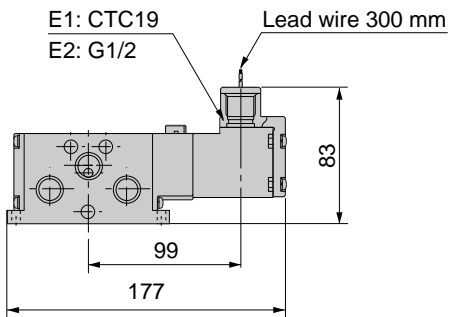

● Manual position change: (R)

\* Attention is required in mounting because the DIN terminal box becomes lower than the mounting surface.

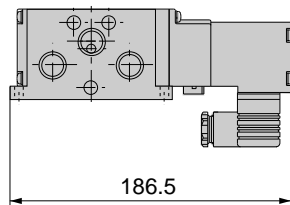

MN3E0
MN4E0
4GA/B
M4GA/B
MN4GA/B
4GA/B (Master)
W4GA/B2
W4GB4
MN3S0
MN4S0
4TB
4L2-4/LMF0
4SA/B0
4SA/B1
4KA/B
<b>4F</b>
PV5G/CMF
PV5/CMF
3MA/B0
3PA/B
P/M/B
NP/NAP/NVP
4F*0E
HMV
HSV
2QV
3QV
SKH
PCD/FS/FD
Ending

Individual wiring manifold  
5 port pilot operated valve

# M4F3 Series

Individual wiring manifold: Body porting

Dimensions



## M4F310 (2-position single solenoid)

● Common exhaust / L bracket: Small terminal box (CL)

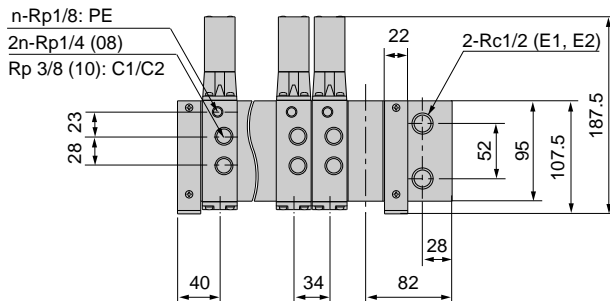
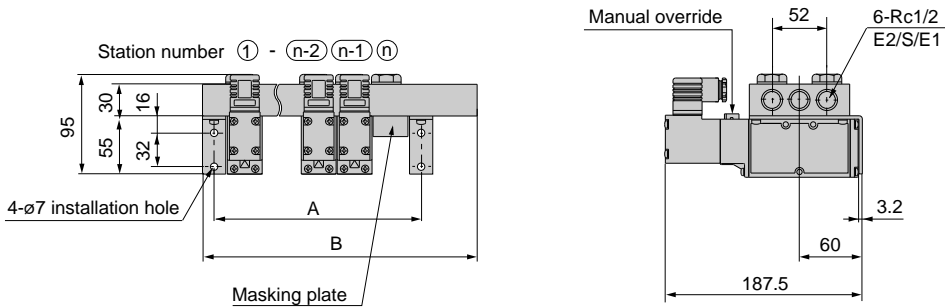
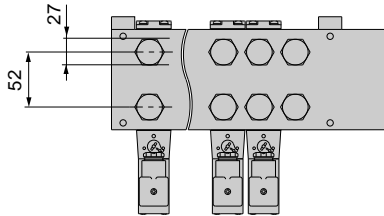

● Individual exhaust / L bracket (IL)

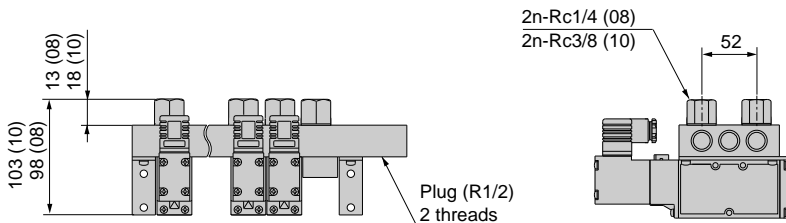

Common exhaust / individual exhaust type

Station number	2	3	4	5	6	7	8	9	10
<b>A</b>	92	126	160	194	228	262	296	330	364
<b>B</b>	156	190	224	258	292	326	360	394	428

\* Refer to page 954 for a check valve.

### Dimensions

● Grommet lead wire: (E)

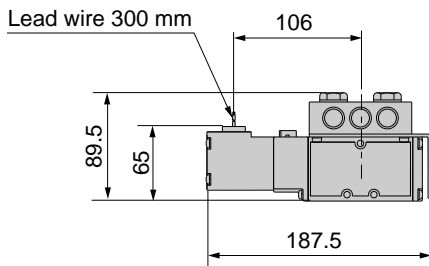

● Conduit lead wire: (E1/E2)

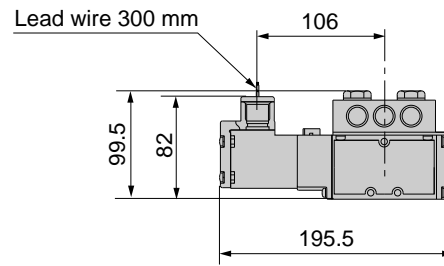

● Manual position change: (R)

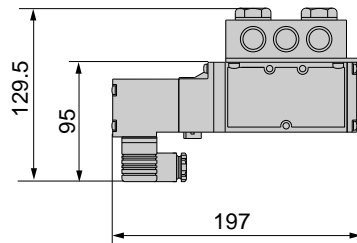

MN3E0
MN4E0
4GA/B
M4GA/B
MN4GA/B
4GA/B (Master)
W4GA/B2
W4GB4
MN3S0
MN4S0
4TB
4L2-4/ LMF0
4SA/B0
4SA/B1
4KA/B
<b>4F</b>
PV5G/ CMF
PV5/ CMF
3MA/B0
3PA/B
P/M/B
NP/NAP/ NVP
4F*0E
HMV
HSV
2QV
3QV
SKH
PCD/ FS/FD
Ending

Individual wiring manifold  
5 port pilot operated valve

# M4F3 Series

## Individual wiring manifold: Body porting

### Dimensions



### M4F3<sup>1</sup>/<sub>3</sub>20

● Common exhaust / U bracket: Small terminal box (CU)

\* Manual position change (R) type is recommended.

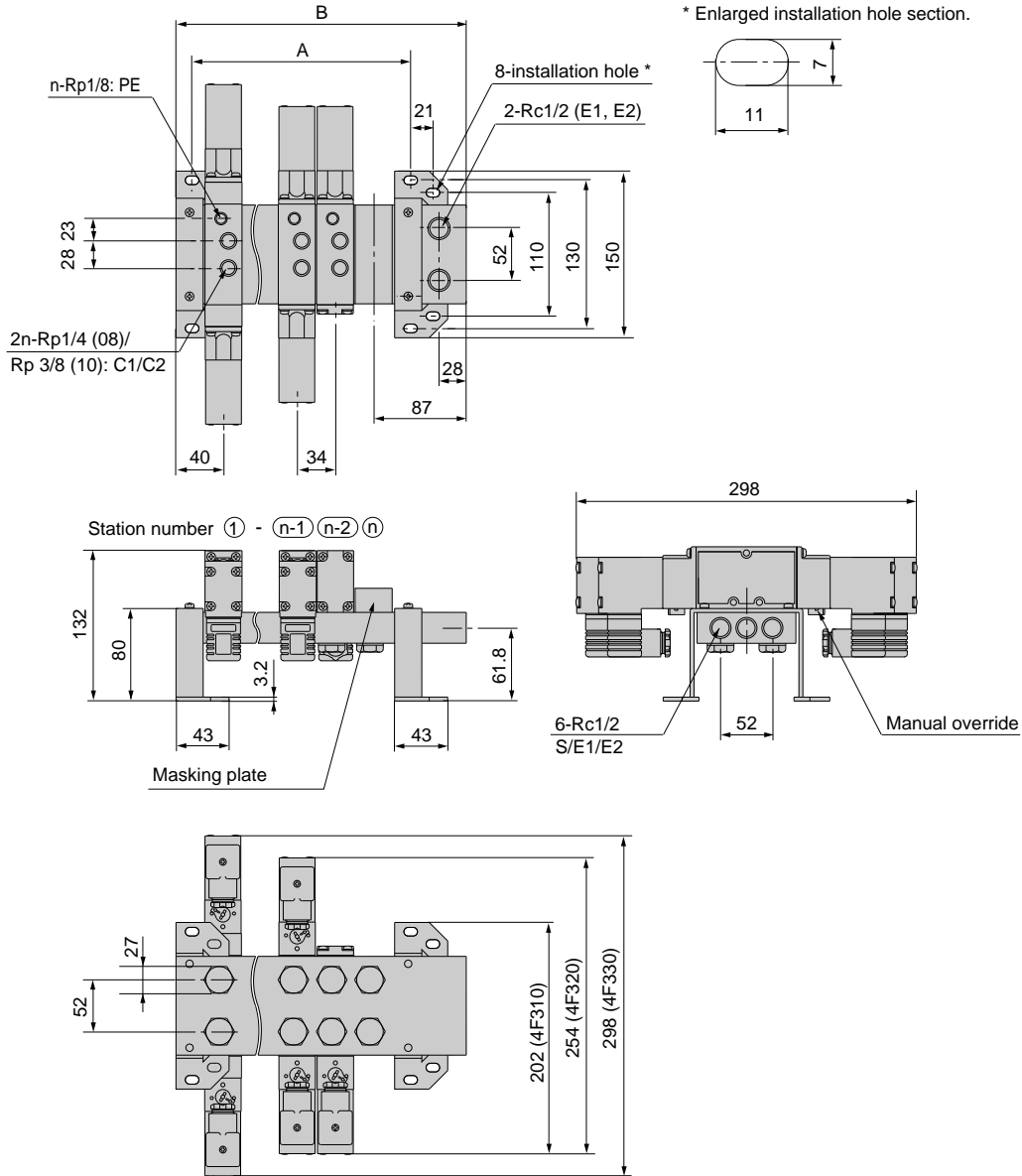

● Individual exhaust / U bracket (IU)

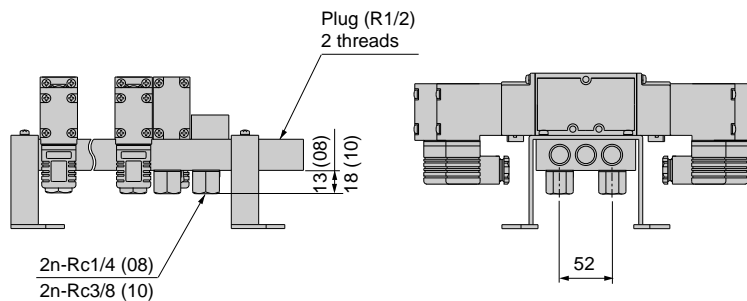

### Common exhaust / individual exhaust type

Station number	2	3	4	5	6	7	8	9	10
A	92	126	160	194	228	262	296	330	364
B	156	190	224	258	292	326	360	394	428

\* Refer to page 954 for a check valve.

### Dimensions

● Grommet lead wire: (E)

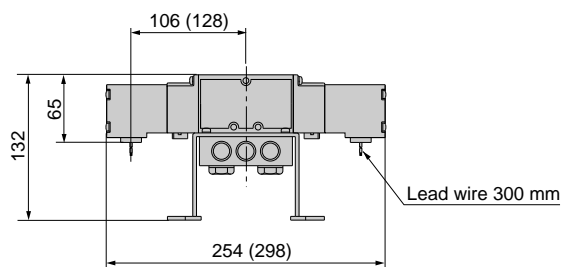

● Conduit lead wire: (E1/E2)

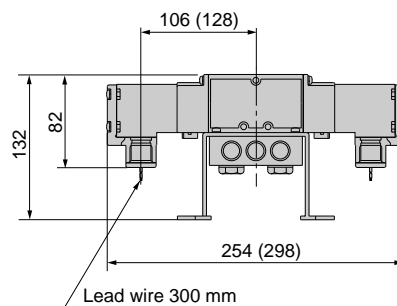

● Manual position change: (R)

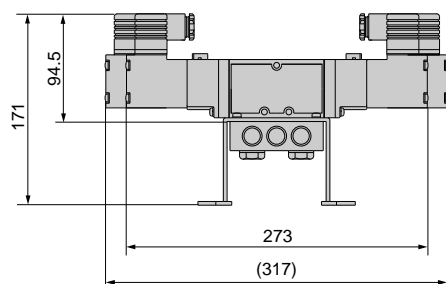

\* Values in ( ) are dimensions of 3-position.

MN3E0
MN4E0
4GA/B
M4GA/B
MN4GA/B
4GA/B (Master)
W4GA/B2
W4GB4
MN3S0
MN4S0
4TB
4L2-4/ LMF0
4SA/B0
4SA/B1
4KA/B
<b>4F</b>
PV5G/ CMF
PV5/ CMF
3MA/B0
3PA/B
P/M/B
NP/NAP/ NVP
4F*0E
HMV
HSV
2QV
3QV
SKH
PCD/ FS/FD
Ending

Individual wiring manifold  
5 port pilot operated valve

# M4F3 Series

## Individual wiring manifold: Body porting

### Dimensions



### M4F3\*0

- Individual exhaust (I)
- Common exhaust (C)

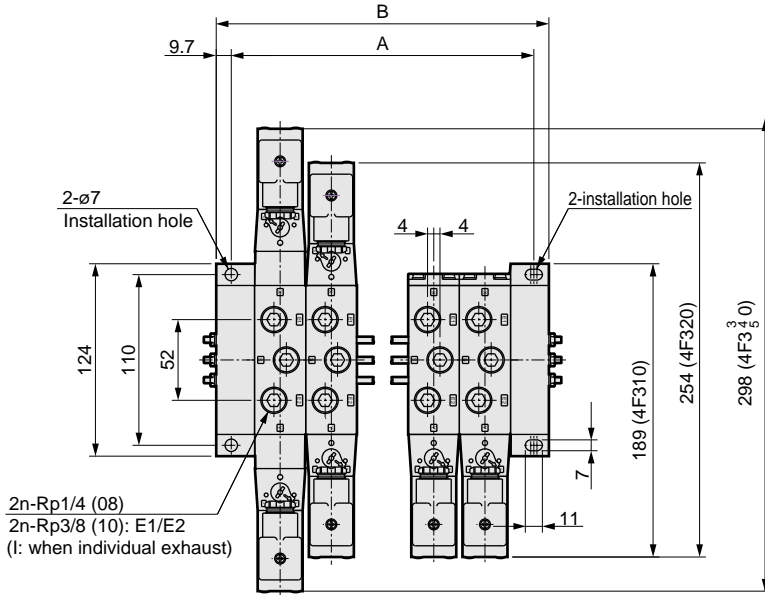

Station number ① ② ... ③

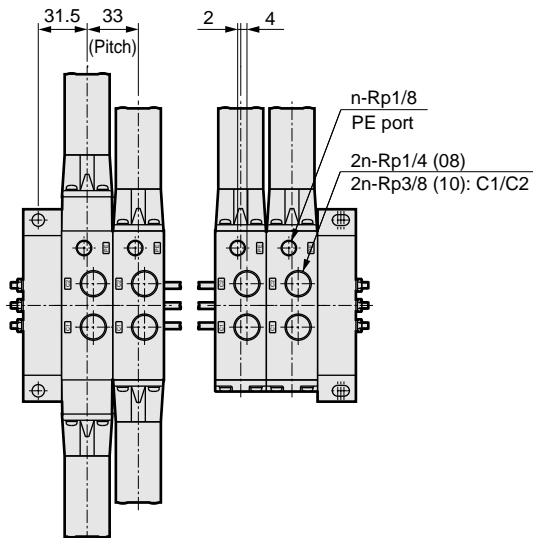
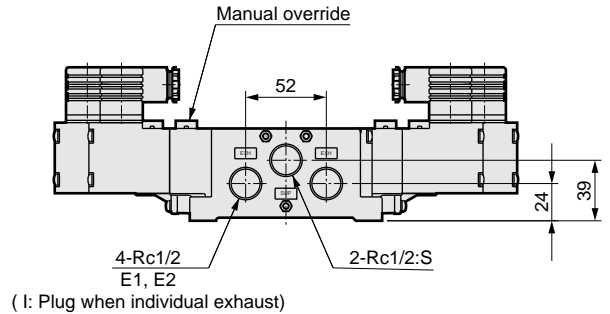
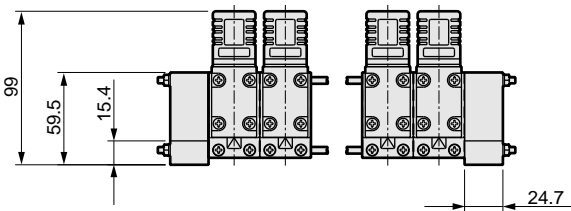

Individual exhaust type  
Common exhaust type

Station number	2	3	4	5	6	7	8	9	10
<b>A</b>	96	129	162	195	228	261	294	327	360
<b>B</b>	115.4	148.4	181.4	214.4	247.4	280.4	313.4	346.4	379.4

### Dimensions

● DIN terminal box with indicator light: (L)

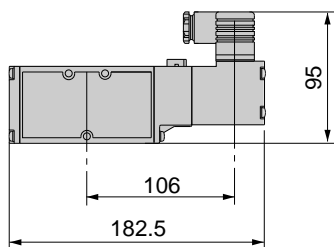

● Grommet lead wire: (E)

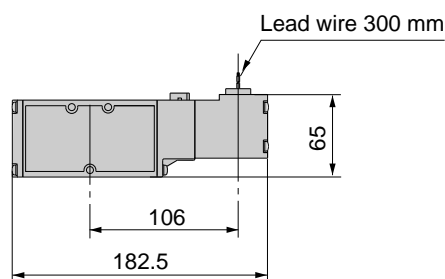

● Conduit lead wire: (E1/E2)

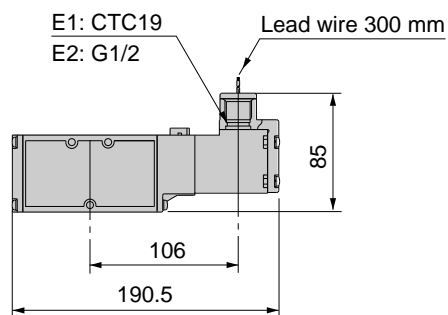

● Manual position change: (R)

\* Attention is required in mounting because the DIN terminal box becomes lower than the mounting surface.

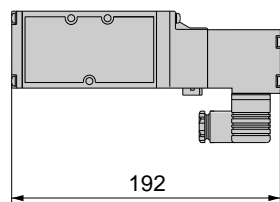

MN3E0
MN4E0
4GA/B
M4GA/B
MN4GA/B
4GA/B (Master)
W4GA/B2
W4GB4
MN3S0
MN4S0
4TB
4L2-4/ LMFO
4SA/B0
4SA/B1
4KA/B
<b>4F</b>
PV5G/ CMF
PV5/ CMF
3MA/B0
3PA/B
P/M/B
NP/NAP/ NVP
4F*0E
HMV
HSV
2QV
3QV
SKH
PCD/ FS/FD
Ending

Individual wiring manifold  
5 port pilot operated valve

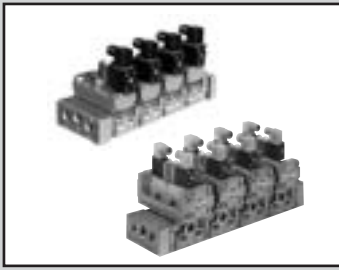

# Individual wiring manifold and sub-plate porting 5 port pilot operated pneumatic valve

## M4F4/5/6/7 Series

● Applicable cylinder bore size:  $\phi 63$  to  $\phi 250$



Refer to Intro 17 for details.



### JIS symbol

#### ● 5 port valve

2-position single solenoid

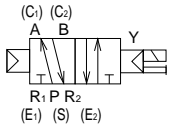

2-position double solenoid

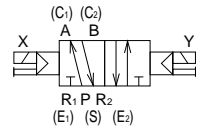

3-position  
all ports closed

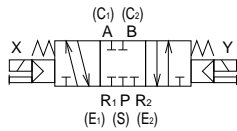

3-position A/B/R connection

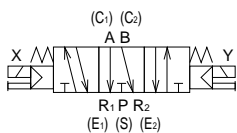

3-position P/A/B connection

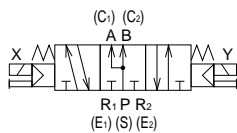

#### ● External pilot

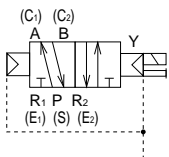

(Symbol for 2-position single solenoid)

### Common specifications

Descriptions	
Manifold method	Manifold integrated
Manifold type	Common supply / common exhaust
Station number	2 to 10 stations
Valve and operation type	Pilot operated spool valve
Working fluid	Compressed air
Max. working pressure MPa	1.0
Min. working pressure MPa	Refer to the individual specifications below.
Withstanding pressure MPa	1.5
Ambient temperature °C	-10 to 60 (no freezing)
Fluid temperature °C	5 to 60
Lubrication	Not required (when lubricating, use turbine oil ISO VG32)
Protective structure	Dust proof
Vibration/impact m/s <sup>2</sup>	50 or less / 300 or less
Working environment	Containing corrosive gas is impermissible.

Note 1: Ambient temperature refers to the temperature for storage and installation, and differs from fluid temperature, which applies during operation.

Note 2: The working pressure range is 0 to 1.0 MPa when the external pilot (option symbol: K) is selected. Set the external pilot pressure between 0.15 and 1.0 MPa.

### Individual specifications

Descriptions		4F4	4F5	4F6	4F7	
Min. working pressure MPa	2-position	Single solenoid	0.10	0.10	0.15	
		Double solenoid				
	3-position	All ports closed	0.15	0.15		0.15
		A/B/R connection				
Port size	P (S) port		Rc3/8	Rc1/2	Rc3/4	Rc 1
	R <sub>1</sub> (E <sub>1</sub> ), R <sub>2</sub> (E <sub>2</sub> ) port		Rc3/8	Rc1/2	Rc3/4	Rc3/4
	A (C), B (C) port		Rc1/4	Rc3/8	Rc1/2	Rc3/4
Response time	Note 2	ms	60	70	200	300

Note 1: G threads and NPT threads are available for the piping port threads. Contact CKD for information.

Note 2: Response time is the value when supply pressure 0.5 MPa, not lubricated and ON. The value varies depending on pressure and quality of lubricant.

### Electric specifications

Descriptions		4F4 to 7	
Rated voltage	AC	100, 200 (50 / 60Hz)	
	V DC	24	
Rated voltage fluctuation range		±10%	
Starting current	AC	100 V	0.170 / 0.140
		200 V	0.090 / 0.070
	A DC	12 V	0.50
		24 V	0.250
Holding current	AC	100 V	0.100 / 0.080
		200 V	0.050 / 0.040
	A DC	12 V	0.50
		24 V	0.250
Power consumption	AC	100 V	5.0 / 4.0
		200 V	5.0 / 4.0
	W DC	12 V	6
		24 V	6
Heat proof class		B (molded coil)	

Note 1: The 100 VAC 50/60 Hz rated voltage can be used at 110 VAC 60 Hz, and 200 VAC 50/60 Hz can be used at 220 VAC 60 Hz.



### Flow characteristics

Model no.	Solenoid position	Port size	C (dm <sup>3</sup> / (s·bar))	b	S (mm <sup>2</sup> )	
4F4	2-position	Single solenoid	Rc1/4	5.0	0.21	-
		Double solenoid				
	3-position	All ports closed		4.7	0.24	
		A/B/R connection		5.3	0.29	
		P/A/B connection		5.3	0.29	
4F5	2-position	Single solenoid	Rc3/8	10	0.32	-
		Double solenoid				
	3-position	All ports closed		9.7	0.28	
		A/B/R connection		9.8	0.25	
		P/A/B connection				
4F6	2-position	Single solenoid	Rc1/2	18	0.31	-
		Double solenoid				
	3-position	All ports closed		15	0.23	
		A/B/R connection				
		P/A/B connection				
4F7	2-position	Single solenoid	Rc3/4	-	-	160
		Double solenoid				
	3-position	All ports closed		-	-	
		A/B/R connection				
		P/A/B connection				

Note 1: Effective sectional area S and sonic conductance C are converted as  $S \doteq 5.0 \times C$ .

### Copper and PTFE free

- Flow path free of copper-based and PTFE-based materials

\*\* - Voltage - **P6**

MN3E0
MN4E0
4GA/B
M4GA/B
MN4GA/B
4GA/B (Master)
W4GA/B2
W4GB4
MN3S0
MN4S0
4TB
4L2-4/ LMF0
4SA/B0
4SA/B1
4KA/B
<b>4F</b>
PV5G/ CMF
PV5/ CMF
3MA/B0
3PA/B
P/M/B
NP/NAP/ NVP
4F*0E
HMV
HSV
2QV
3QV
SKH
PCD/ FS/FD
Ending

Individual wiring manifold  
5 port pilot operated valve

# M4F4 to 7 Series

## Individual wiring manifold: Sub-plate porting

### Individual wiring manifold: How to order sub-plate porting

● Discrete solenoid valve for manifold

● Manifold

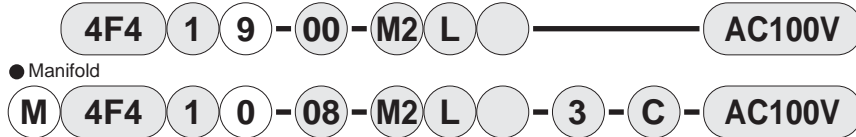

\* Fill out "Manifold specification sheet" (page 958 to 959)

**A** Model no.

**B** Solenoid position

**C** Port size

**D** Manual override

**E** Electric connection

Note 1: DC type DIN terminal box with light (L) has a built-in surge suppressor. (Refer to page 887 for circuit diagram.)

**F** Other options

**G** Station number

**H** Exhaust mounting method

**I** Voltage

Indicate the quantity and display position of each valve function for the mixed manifold. Refer to the following page.

**A** Model no.

4	4	4	4
F	F	F	F
4	5	6	7

Symbol	Descriptions	4	5	6	7
<b>B Solenoid position</b>					
1	2-position single solenoid	●	●	●	●
2	2-position double solenoid	●	●	●	●
3	3-position all ports closed	●	●	●	●
4	3-position A/B/R connection	●	●	●	●
5	3-position P/A/B connection	●	●	●	●
8	Mix manifold	●	●	●	●

<b>C Port size</b>					
08	Rc1/4	●			
08Y	Rc1/4 (cylinder port rear side)	●			
10	Rc3/8		●		
10Y	Rc3/8 (cylinder port rear side)		●		
D15	Rc1/2			●	
E20	Rc3/4				●

<b>D Manual override</b>					
Blank	Locking	●	●	●	●
M2	Non-locking	●	●	●	●
M3	Locking with manual lever Note 4	●	●	●	●

<b>E Electric connection</b>					
Blank	DIN terminal box (Pg11)	●	●	●	●
L	DIN terminal box (Pg11) with light Note 1	●	●	●	●
F	DIN terminal box (G1/2)	●	●	●	●
E	Grommet lead wire	●	●	●	●
E1	Conduit lead wire (CTC19)	●	●	●	●
E2	Conduit lead wire (G1/2)	●	●	●	●
B1	Round terminal box (G3/4)		●	●	●
B	Round terminal box (G1/2)		●	●	●
BL	Round terminal box (G1/2) with light Note 5		●	●	●
G	Round terminal box with gland (A-15a)		●	●	●
GL	Round terminal box with gland (A-15a), light Note 5		●	●	●

<b>F Other options</b>					
Blank	No option	●	●	●	●
K	External pilot Note 2	●	●	●	●
S	Surge suppressor (variable resistor) attached	●	●	●	●
N	Plug attached (3 port valve)	●	●	●	●
NC	3 way valve (C1: A.E1: R1) plug assembly	●	●	●	●
NO	3 way valve (C2: B.E2: R2) plug assembly	●	●	●	●

<b>G Station number</b>					
2	2 stations				
to	to	●	●	●	●
10	10 stations				

<b>H Exhaust mounting style</b>					
C	Common exhaust	●	●	●	●

<b>I Voltage</b>					
AC100V	100 VAC 50/60Hz	●	●	●	●
AC200V	200 VAC 50/60Hz	●	●	●	●
DC12V	12 VDC	●	●	●	●
DC24V	24 VDC	●	●	●	●
AC110V	110 VAC 50/60Hz	●	●	●	●
AC220V	220 VAC 50/60Hz	●	●	●	●

### Note on model no. selection

Note 2: Consult CKD for details on using vacuum with the external pilot (K).

Note 3: A gasket and a set screw are included as standard for discrete solenoid valve for manifold.

Note 4: When selecting the DIN terminal box for the lock type with a manual lever, the terminal box must face outward during use.

Note 5: BL and GL 12VDC are not available.

### <Example of model number>

#### M4F440-08-M2ES-5-C-AC100V

- A** Model: M4F4
- B** Solenoid position : 3-position A/B/R connection
- C** Port size : Rc1/4
- D** Manual override : Non-locking
- E** Electric connection : Grommet lead wire
- F** Other options : Surge suppressor attached
- G** Station number : 5 stations
- H** Exhaust method : Common exhaust
- I** Voltage : 100 VAC

### How to order masking plate kit

**M4F4** - **MP-KIT** \* Gasket and set screw attached

**A** Model no.      **B** Port size

A Model no.	B Port size
M4F4	Blank Rc1/4
M4F5	Blank Rc3/8
M4F6	D15 Rc1/2
M4F7	E20 Rc3/4

### How to order mix manifold

**M** **4F4** **8** **0** - **08** - **M2** **L** - **7** - **C** - **AC100V** - **S1 S2 S3 S4 S5 MP**  
**2 2 2 1 0 0**

Mix manifold "8"      \* Refer to the previous page for how to order other manifolds.

S1 = 1, 6    S2 = 2, 5  
S3 = 3, 4    S4 = 7

### How to order Mixed Manifold Models

- (1) Indicate the quantity for each function (solenoid position) at the end of the model. Functions and symbols are indicated below.

Example: 2-position single solenoid → S1

Symbol	Function (solenoid position)
<b>S1</b>	2-position single solenoid
<b>S2</b>	2-position double solenoid
<b>S3</b>	3-position all ports closed
<b>S4</b>	3-position A/B/R connection
<b>S5</b>	3-position P/A/B connection
<b>MP</b>	Masking plate

**S1 S2 S3 S4 S5 MP**  
**2 2 2 1 0 0**  
 Indicate the quantity.

- (2) Indicate the function (solenoid position) and layout position in the Remarks field.

Changeover position symbol: ○, ○th station. (Refer to the dimension drawings (pages 950 to 953) for details on counting stations.)

Example: S1 = 1, 6 (1st, 6th station are 2-position single solenoid.)

### <Example of model number>

For 7 stations

1	2	3	4	5	6	7	.....	Layout
2-position single solenoid	2-position double solenoid	3-position all ports closed	3-position all ports closed	2-position double solenoid	2-position single solenoid	3-position A/B/R connection		
S1	S2	S3	S3	S2	S1	S4		Symbol

- 2-position single solenoid (S1) : 2 piece (1st and 6th station)  
 2-position double solenoid (S2) : 2 piece (2nd and 5th station)  
 3-position all ports closed (S3) : 2 piece (3rd and 4th station)  
 3-position A/B/R connection (S4) : 1 piece (7th station)

↓

M4F480-08-M2L-7-C-AC100V - **S1 S2 S3 S4 S5 MP**  
**2 2 2 1 0 0**  
 S1 = 1, 6    S2 = 2, 5    S3 = 3, 4    S4 = 7

MN3E0
MN4E0
4GA/B
M4GA/B
MN4GA/B
4GA/B (Master)
W4GA/B2
W4GB4
MN3S0
MN4S0
4TB
4L2-4/LMF0
4SA/B0
4SA/B1
4KA/B
<b>4F</b>
PV5G/CMF
PV5/CMF
3MA/B0
3PA/B
P/M/B
NP/NAP/NVP
4F*0E
HMV
HSV
2QV
3QV
SKH
PCD/FS/FD
Ending

Individual wiring manifold  
5 port pilot operated valve

# M4F4 Series

## Individual wiring manifold: Sub-plate porting

### Dimensions



**M4F4**  
1  
2  
3  
4  
5  
0

● Common exhaust: DIN terminal box

\* Enlarged installation hole section.

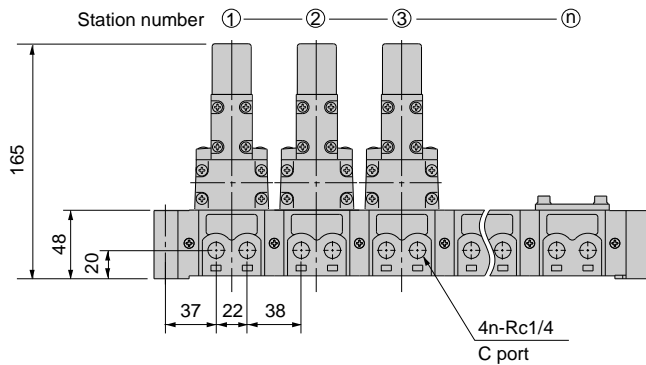
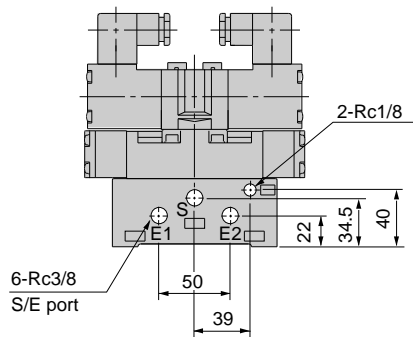
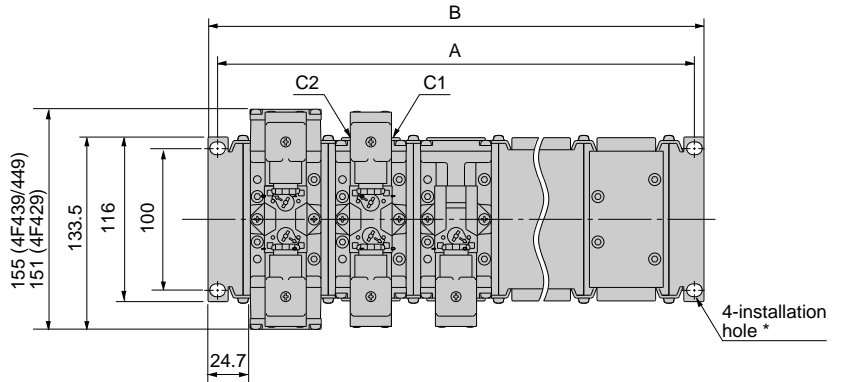
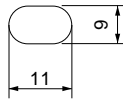

● DIN terminal box with indicator light: (L)

● Conduit lead wire: (E1/E2)

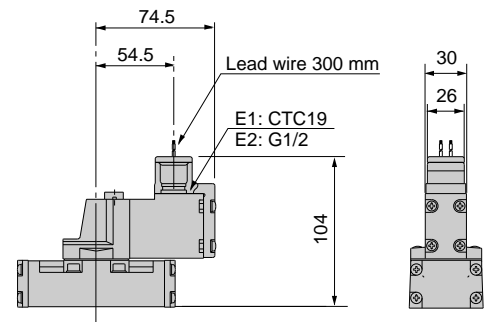
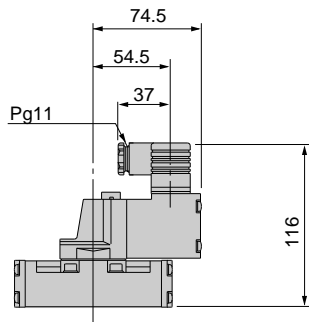

● Grommet lead wire: (E)

● Cylinder port rear side: (08Y)

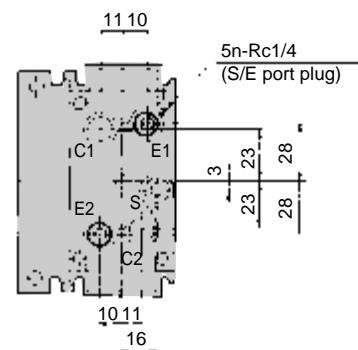
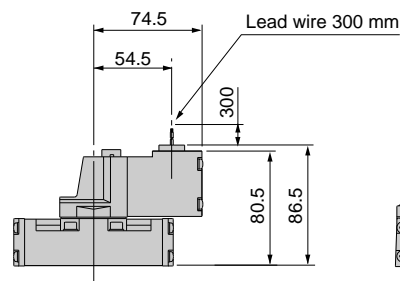

### Common exhaust type

Station number	2	3	4	5	6	7	8	9	10
<b>A</b>	156	216	276	336	396	456	516	576	636
<b>B</b>	169.4	229.4	289.4	349.4	409.4	469.4	529.4	589.4	649.4

\* Individual supply / individual exhaust is custom order.

\* Refer to page 954 for a check valve.

### Dimensions



**M4F5**  
1  
2  
3  
4  
5  
0

● Common exhaust: DIN terminal box

\* Enlarged installation hole section.

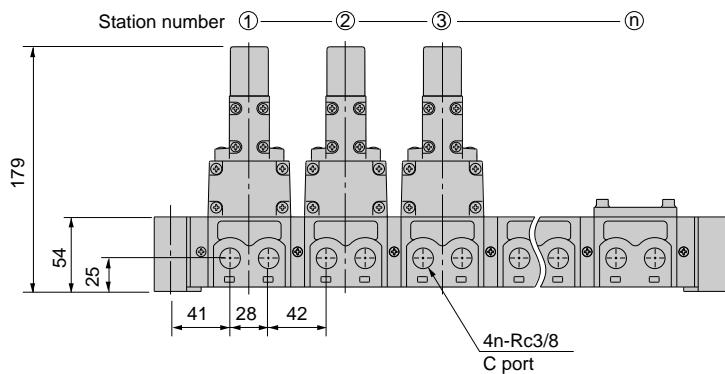
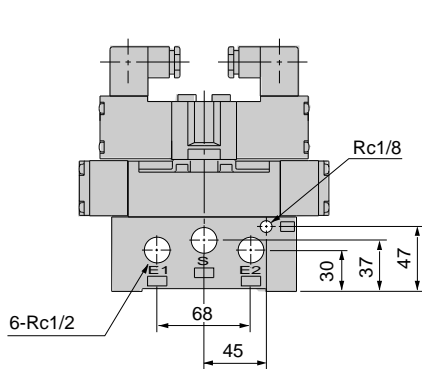
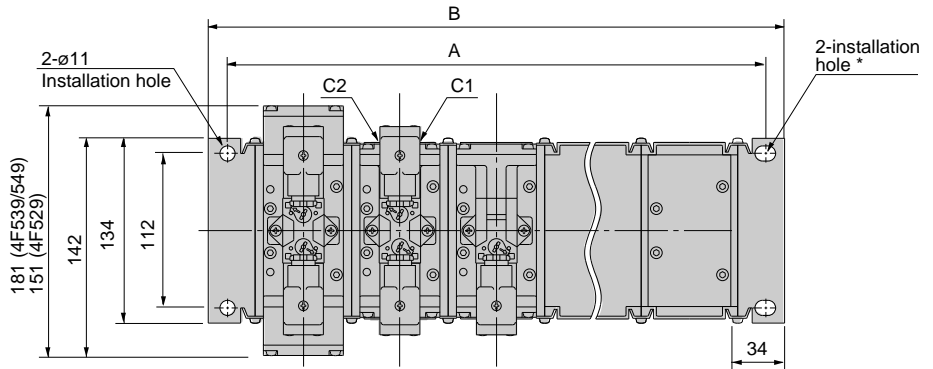
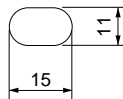

● DIN terminal box with indicator light: (L)

● Conduit lead wire: (E1/E2)

● Round terminal box: (B1/B/BL)

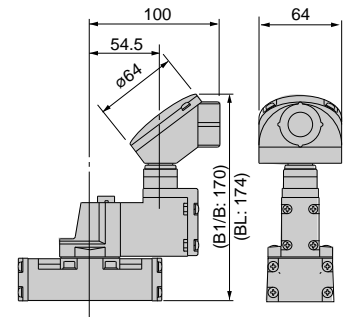
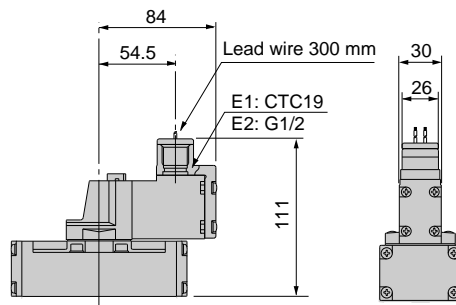
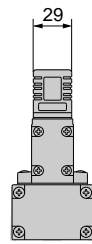
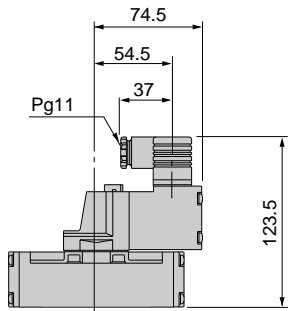

● Grommet lead wire: (E)

● Cylinder port rear side: (10Y)

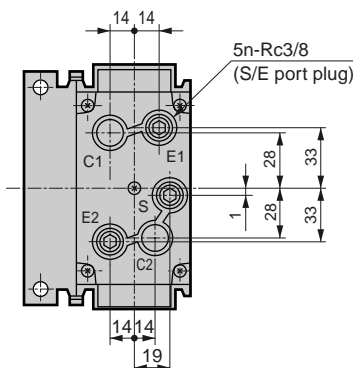
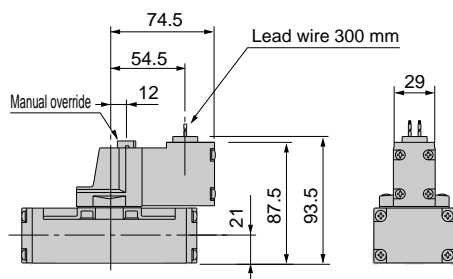

### Common exhaust type

Station number	2	3	4	5	6	7	8	9	10
<b>A</b>	180	250	320	390	460	530	600	670	740
<b>B</b>	208	278	348	418	488	558	628	698	768

\* Individual supply / individual exhaust is custom order.

\* Refer to page 954 for a check valve.

MN3E0
MN4E0
4GA/B
M4GA/B
MN4GA/B
4GA/B (Master)
W4GA/B2
W4GB4
MN3S0
MN4S0
4TB
4L2-4/LMF0
4SA/B0
4SA/B1
4KA/B
<b>4F</b>
PV5G/CMF
PV5/CMF
3MA/B0
3PA/B
P/M/B
NP/NAP/NVP
4F*0E
HMV
HSV
2QV
3QV
SKH
PCD/FS/FD
Ending

Individual wiring manifold  
5 port pilot operated valve

# M4F6 Series

## Individual wiring manifold: Sub-plate porting

### Dimensions



1  
2  
3  
4  
5

**M4F6 3 0**

● Common exhaust: DIN terminal box

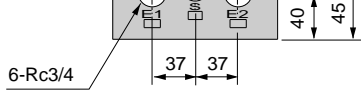
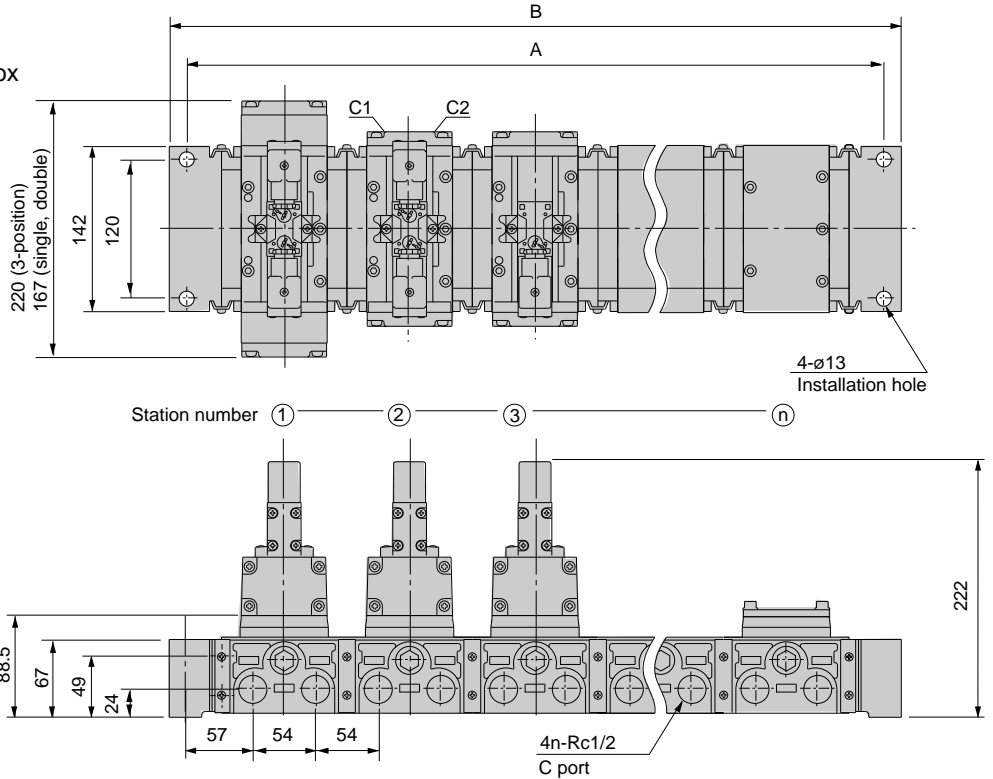

● DIN terminal box with indicator light: (L)

● Conduit lead wire: (E1/E2)

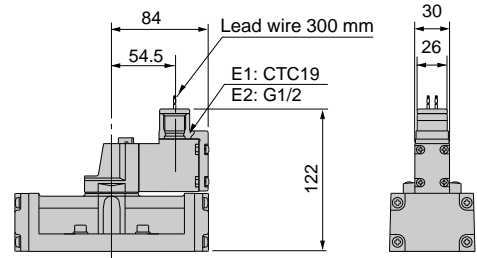
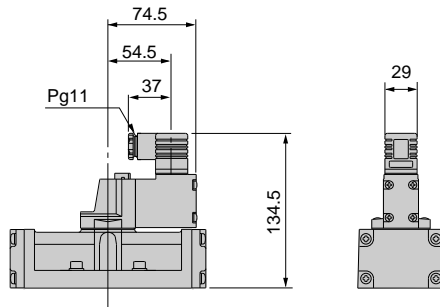

● Grommet lead wire: (E)

● Round terminal box: (B1/B/BL)

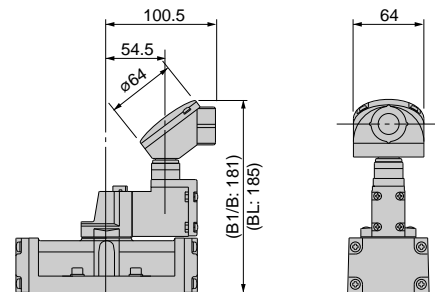
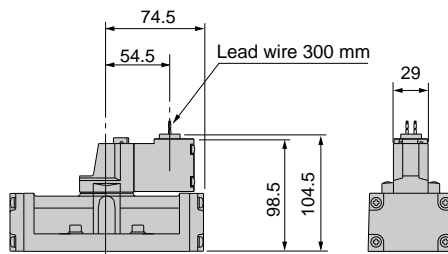

### Common exhaust type

Station number	2	3	4	5	6	7	8	9	10
<b>A</b>	276	384	492	600	708	816	924	1032	1140
<b>B</b>	306	414	522	630	738	846	954	1062	1170

\* Individual supply / individual exhaust is custom order.

\* Refer to page 954 for a check valve.

### Dimensions



1  
2  
**M4F7 3 0**  
4  
5

● Common exhaust: DIN terminal box

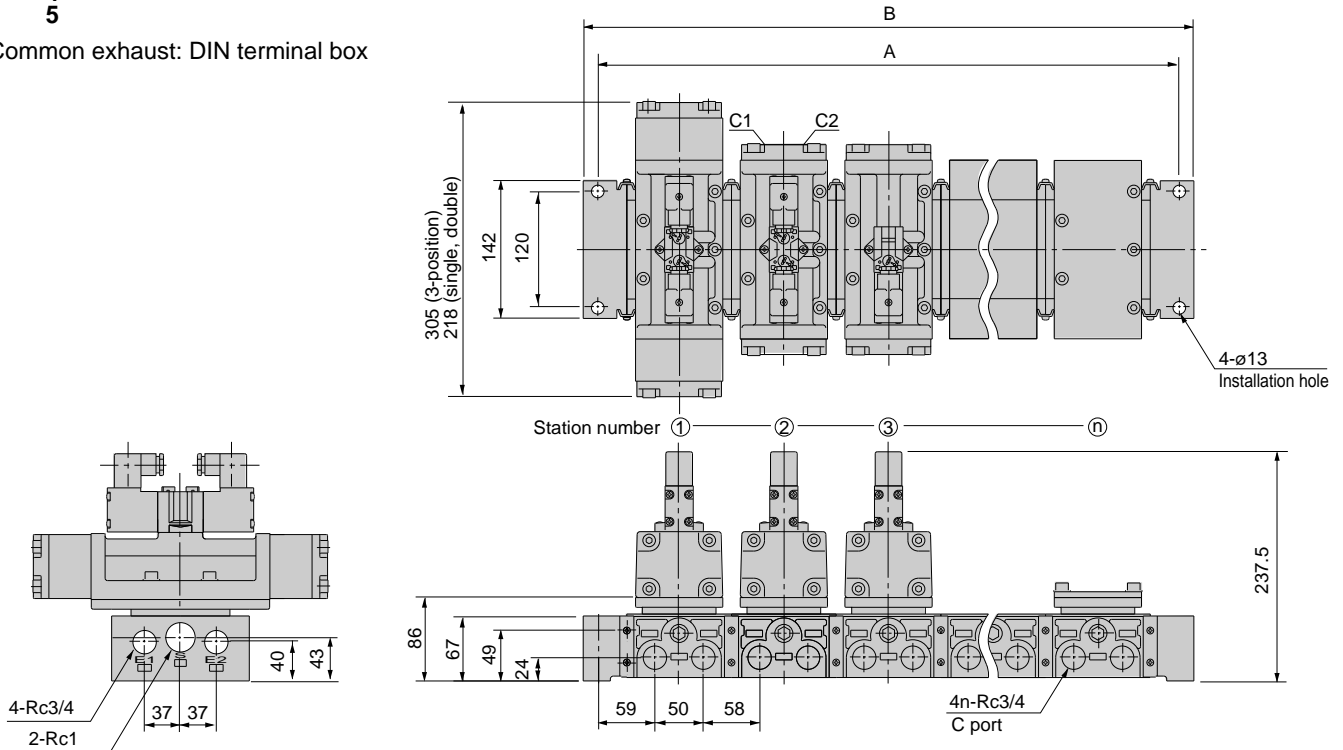

● DIN terminal box with indicator light: (L)

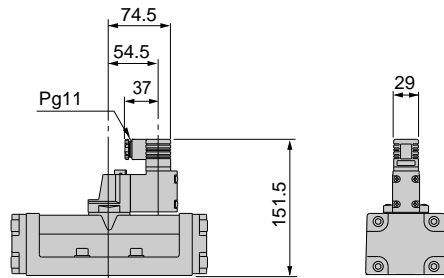

● Conduit lead wire: (E1/E2)

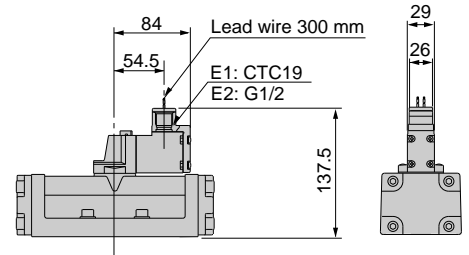

● Grommet lead wire: (E)

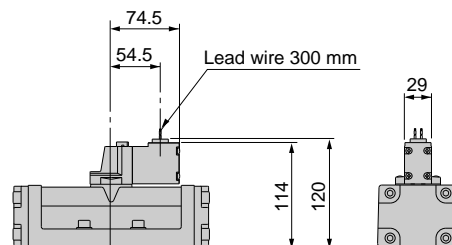

● Round terminal box: (B, B1, BL)

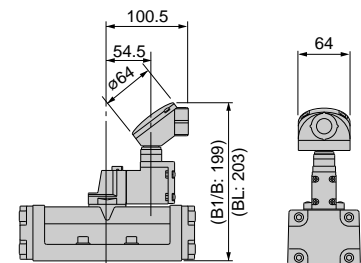

### Common exhaust type

Station number	2	3	4	5	6	7	8	9	10
<b>A</b>	276	384	492	600	708	816	924	1032	1140
<b>B</b>	306	414	522	630	738	846	954	1062	1170

\* Refer to page 954 for a check valve.

MN3E0
MN4E0
4GA/B
M4GA/B
MN4GA/B
4GA/B (Master)
W4GA/B2
W4GB4
MN3S0
MN4S0
4TB
4L2-4/LMF0
4SA/B0
4SA/B1
4KA/B
<b>4F</b>
PV5G/CMF
PV5/CMF
3MA/B0
3PA/B
P/M/B
NP/NAP/NVP
4F*OE
HMV/HSV
2QV
3QV
SKH
PCD/FS/FD
Ending

Individual wiring manifold  
5 port pilot operated valve



# 4F Series

Check valve / round terminal box / adaptor / DIN terminal

## 3-position check valve (H) dimensions

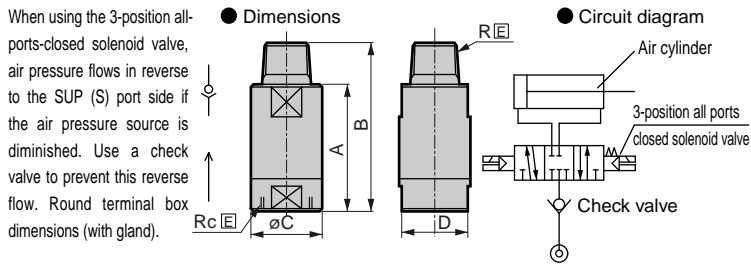

Model no.	A	B	C	D	E	Effective sectional area mm <sup>2</sup>	Cracking pressure
AC- 8A	49	63	20	17	1/4	20	0.05 MPa
AC-10A	55	70	25	22	3/8	40	
AC-15A	60	80	33	30	1/2	80	
AC-20A	70	92	50	46	3/4	160	
AC-25A	75	100	50	46	1	160	

(Other than B/BL/G/GL is custom order.)

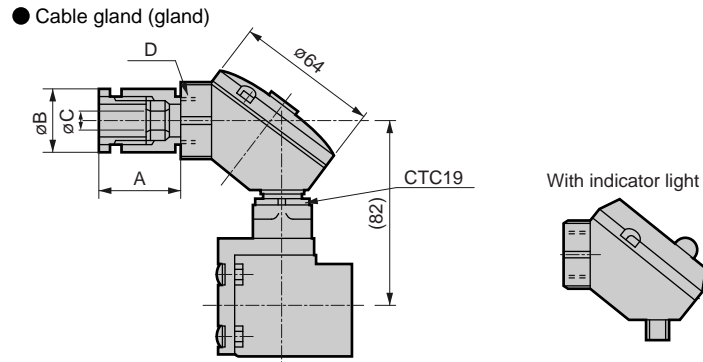

Type	A	B	C	D	Option symbol
A-15a	39	28	9	G1/2	G1†
A-15b	39	28	10		G2†
A-15c	39	28	11		G3†
A-20a	43	34	12	G3/4	G4†
A-20b	43	34	13		G5†
A-20c	43	34	15		

Note 1: \*dimension is a reference.  
Note 2: Determine a, b and c from the lead-out cable size using the C dimension as reference.

Square terminal box dimensions (with gland) (Custom order)

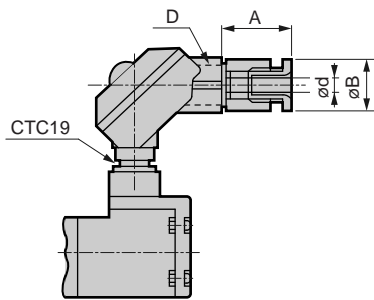

Type	A	B	D	d	Option symbol
A-15a	39	28	G1/2	9	T <sup>†</sup> G
A-15b	39	28	G1/2	10	T <sup>†</sup> G1
A-15c	39	28	G1/2	11	T <sup>†</sup> G2

## Adaptor (option)

When combining 4F series actuator and F series sub-plate, use the adaptor. (Consult with CKD for details.)

How to install discrete 4F4 to 7

### ● Installation

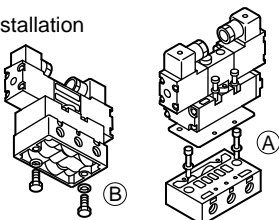

	For B	For A
4F4	M 8	M 6
4F5	M 8	M 6
4F6	M10	M 8
4F7	M12	M10

## Coil option

Model no.	Round terminal box G1/2	Round terminal box G3/4 (Custom order)	Round terminal box with gland (Other than G, GL is custom order)
B	Without light		
BL	With light		
B1	Without light		
B1L	With light		
G	A-15a	Without light	
GL	A-15a	With light	
G1	A-15b	Without light	
G1L	A-15b	With light	
G2	A-15c	Without light	
G2L	A-15c	With light	
G3	A-20a	Without light	
G3L	A-20a	With light	
G4	A-20b	Without light	
G4L	A-20b	With light	
G5	A-20c	Without light	
G5L	A-20c	With light	

Note: The round terminal box cannot be used with the 4F2 to 4 manifold because it contacts other parts.

## Coil option

Model no.	Square terminal box G1/2 (Custom order)	Square terminal box with gland (Custom order)
TB	Without light	
TL	With light	
TBG	A-15a	Without light
TLG	A-15a	With light
TBG1	A-15b	Without light
TLG1	A-15b	With light
TBG2	A-15c	Without light
TLG2	A-15c	With light

Note: The square terminal box cannot be used with the 4F2/3 manifolds due to interference.

The CKD-recommended cabtyre cable is indicated by a circle (○) in the table.

Vinyl cabtyre cable (VCT multi-core JIS C3312)			Marine cable gland (JIS F8801)				Upper row: Model no. (Lower row: Gasket diameter)	
Nominal section area	No. of conductor	Finished O.D.	15a (ø9)	15b (ø10)	15c (ø11)	20a (ø12)	20b (ø13)	20c (ø15)
0.75 mm <sup>2</sup>	2	ø8.8	○					
	3	9.2	○					
	4	9.9		○				
1.25	2	9.6		○				
	3	10.5			○			
	4	11.5				○		
2	2	10.5			○			
	3	11			○			
	4	12				○		
3.5	2	12				○	○	
	3	13					○	
	4	14						○

Note: This table shows relations between marine cable gland and cabtyre.

## DIN terminal (option)

When using a metal or flexible pipe with the DIN terminal box F type (G 1/2), the gland gasket and washer should be removed.

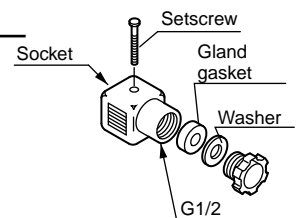

## Rp (PS) screw

Rp threads are used on 4F0 to 4F3 to enable assembly on the manifold. Rp threads are commonly used because parallel female threads fit into tapered male threads. (Described in JIS.)



MEMO

	MN3E0 MN4E0
	4GA/B
	M4GA/B
	MN4GA/B
	4GA/B (Master)
	W4GA/B2
	W4GB4
	MN3S0 MN4S0
	4TB
	4L2-4/ LMF0
	4SA/B0
	4SA/B1
	4KA/B
	<b>4F</b>
	PV5G/ CMF
	PV5/ CMF
	3MA/B0
	3PA/B
	P/M/B
	NP/NAP/ NVP
	4F*0E
	HMV HSV
	2QV 3QV
	SKH
	PCD/ FS/FD
	Ending
	Individual wiring manifold 5 port pilot operated valve

# M4F0 to 3 manifold specification sheet

Issue / /

Your company name

Contact

Order No.

● Contact                      ● Quantity                      set                      ● Request date

Slip No.	Order No.
----------	-----------

Exhaust mounting / with bracket (CL, CU, IL, IU)

By instructing the mixed piping port, or mixed exhaust method, etc., in these manifold specifications, the product will be assembled and delivered from CKD.

When using these specifications to place an order, consult CKD about the manifold model, etc.

● Manifold model no.

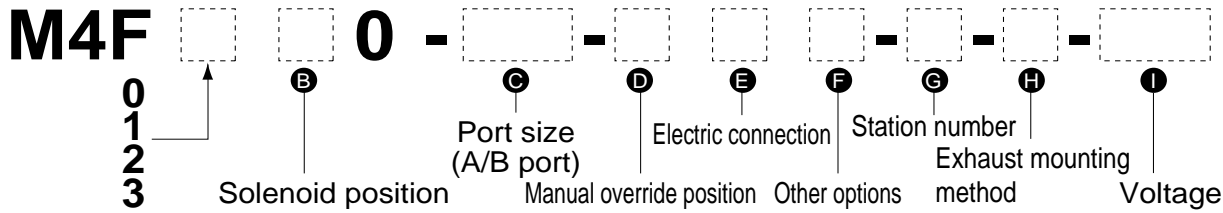

Solenoid valve	Installation position										Sub-total	Total			
	JIS symbol	Model	Port size	1	2	3	4	5	6	7			8	9	10
2-position single solenoid		4F													
2-position double solenoid		4F													
3-position all ports closed		4F													
3-position A/B/R connection		4F													
3-position P/A/B connection		4F													
Masking plate															
Indicate for individual and common mix.	R <sub>1</sub> port circuit														
	R <sub>2</sub> port circuit														
3 way valve specifications	N.C. (C1: Plug to A)														
	N.O. (C2: Plug to B)														

Position / No. of solenoid and cylinder port size (cylinder port other than below is not available.)

Position / No. of solenoid	Series	Manifold model no.	Station number	
			Cylinder port	C
● 2-position single	M4F0	AM4F010	2 to 10	M5
● 2-position double		M4F020		Rp1/8
● 3-position all ports closed	M4F1	M4F110	2 to 10	Rp1/8
● 3-position A/B/R connection		120		Rp1/4
● 3-position P/A/B connection		130		
● 2-position single	M4F2	M4F210	2 to 10	Rp1/4
● 2-position double		220		
● 3-position all ports closed		230		
● 3-position A/B/R connection	M4F3	M4F310	2 to 10	Rp1/4
● 2-position double		320		Rp3/8
● 3-position all ports closed		330		
● 3-position A/B/R connection		340		
● 3-position P/A/B connection		350		

Note: Mixed type is not available for the 4F0/1/2//3 Series.

# M4F2/3 manifold specification sheet

Issue / /

Your company name

● Contact      ● Quantity      set      ● Request date

Contact

Slip No.	Order No.
----------	-----------

Order No.

Exhaust mounting / without bracket (C, I)

By instructing the mixed piping port, partition plate, mixed exhaust method, or individual exhaust etc., in these manifold specifications, the product will be assembled and delivered from CKD.

When using these specifications to place an order, consult CKD about the manifold model, etc.

● Manifold model no.

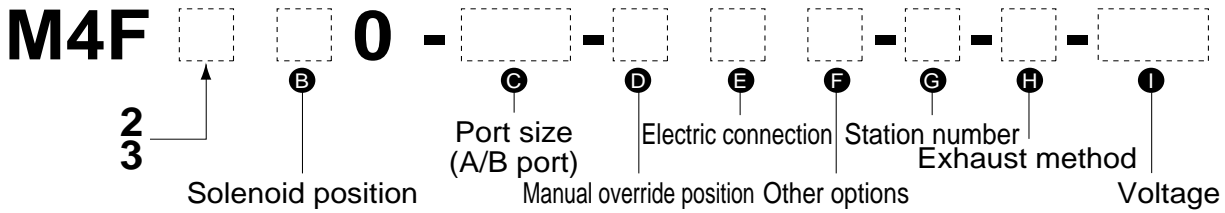

Solenoid valve			Installation position										Sub-total	Total
JIS symbol	Model	Port size	1	2	3	4	5	6	7	8	9	10		
2-position single solenoid	4F [ ]													
2-position double solenoid	4F [ ]													
3-position all ports closed	4F [ ]													
3-position A/B/R connection	4F [ ]													
3-position P/A/B connection	4F [ ]													
Masking plate														
Partition plate	P port circuit													
	R <sub>1</sub> port circuit													
	R <sub>2</sub> port circuit													
3 way valve specifications	N.C. (C1: Plug to A)													
	N.O. (C2: Plug to B)													

Position / No. of solenoid and cylinder port size (cylinder port other than below is not available.)

Position / No. of solenoid					Series	Manifold model no.	Station number	
2-position single	2-position double	3-position all ports closed	3-position A/B/R connection	3-position P/A/B connection			Cylinder port	C
●					M4F2	M4F210	2 to 10	Rp1/4
	●					220		
		●				230		
			●			240		
●					M4F3	M4F310		Rp1/4 Rp3/8
	●					320		
		●				330		
			●			340		
				●		350		

Note: Mixed type is not available for the 4F2/3 Series.

MN3E0  
MN4E0

4GA/B

M4GA/B

MN4GA/B

4GA/B  
(Master)

W4GA/B2

W4GB4

MN3S0  
MN4S0

4TB

4L2-4/  
LMF0

4SA/B0

4SA/B1

4KA/B

**4F**

PV5G/  
CMF

PV5/  
CMF

3MA/B0

3PA/B

P/M/B

NP/NAP/  
NVP

4F\*0E

HMV  
HSV

2QV  
3QV

SKH

PCD/  
FS/FD

Ending

Individual wiring manifold  
5 port pilot operated valve

MN3E0  
MN4E0

4GA/B

M4GA/B

MN4GA/B

4GA/B  
(Master)

W4GA/B2

W4GB4

MN3S0  
MN4S0

4TB

4L2-4/  
LMF0

4SA/B0

4SA/B1

4KA/B

**4F**

PV5G/  
CMF

PV5/  
CMF

3MA/B0

3PA/B

P/M/B

NP/NAP/  
NVP

4F\*0E

HMV  
HSV

2QV  
3QV

SKH

PCD/  
FS/FD

Ending

# M4F4/5 manifold specification sheet

Issue / /

Your company name

Contact

Order No.

● Contact      ● Quantity      set      ● Request date

Slip No.	Order No.
----------	-----------

By instructing 4F4/5 solenoid valve combination, piping port change, partition plate, or individual exhaust etc., in these manifold specifications, the product will be assembled and delivered from CKD.  
When using these specifications to place an order, consult CKD about the manifold model, etc.

● Manifold model no.

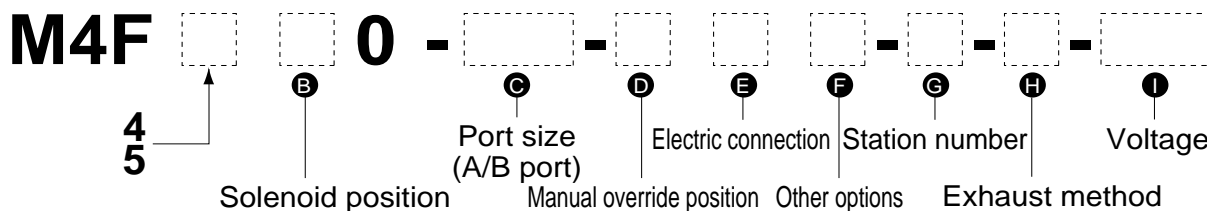

Solenoid valve	Installation position										Sub-total	Total		
	JIS symbol	Model	Port size	1	2	3	4	5	6	7			8	9
2-position single solenoid		4F4	Rc 1/4											
		4F5	Rc 3/8											
2-position double solenoid		4F4	Rc 1/4											
		4F5	Rc 3/8											
3-position all ports closed		4F4	Rc 1/4											
		4F5	Rc 3/8											
3-position A/B/R connection		4F4	Rc 1/4											
		4F5	Rc 3/8											
3-position P/A/B connection		4F4	Rc 1/4											
		4F5	Rc 3/8											
Masking plate														
Partition plate	P port circuit													
	R1 port circuit													
	R2 port circuit													
3 way valve specifications	N.C. (C1: Plug to A)													
	N.O. (C2: Plug to B)													

When inserting one partition plate into the P, R1, or R2 port circuit

When inserting one partition plate in the P, R1, or R2 port circuit, use P, R1, and R2 ports on both sides.

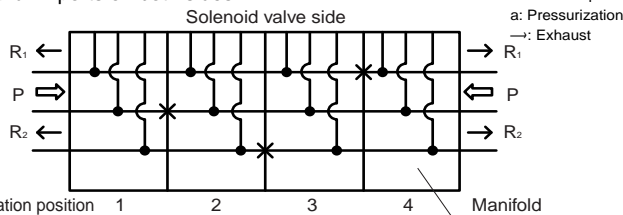

When inserting two or more partition plates into the P, R1 or R2 port circuit

When inserting two or more partition plates into the P port circuit  
The P port circuit in which the partition plate is inserted has the P port on the back of the manifold. (The port is the same size as A and B ports.)  
If the port size is 08Y (4F4) or 10Y (4F5), the A and B ports are also on the back.

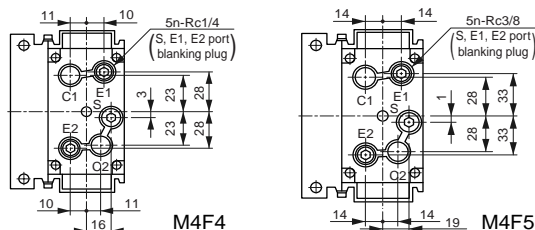

When inserting two or more partition plates into the R1, or R2 port circuit  
The R1 or R2 port circuit in which the partition plate is inserted has the R1 or R2 port on the back of the manifold. (The port is the same size as A and B ports.)

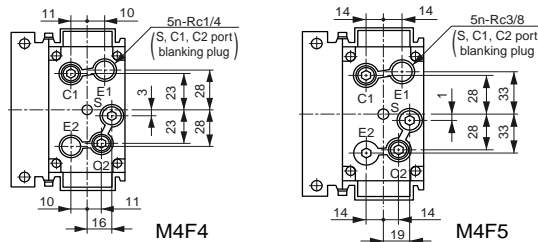

When providing the R port on the manifold side

If an individual exhaust cannot be provided on the back, it is placed on the FS base. (The mounting spacing increases.)

● M4F5\*0-C10 (Note: Base dimensions are the same as for the M4F4-C10.)

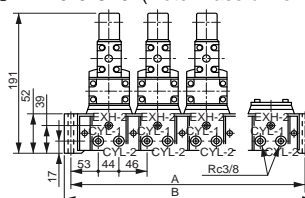

Piping	St. #	2	3	4	5	6	7	8	9	10
A		240	330	420	510	600	690	780	870	960
B		270	360	450	540	630	720	810	900	990

# M4F6/7 manifold specification sheet

Issue / /

Your company name

● Contact      ● Quantity      set      ● Request date

Slip No.	Order No.
----------	-----------

Contact



Order No.

By instructing the piping port change, partition plate, or individual exhaust etc., in these manifold specifications, the product will be assembled and delivered from CKD.

When using these specifications to place an order, consult CKD about the manifold model, etc.

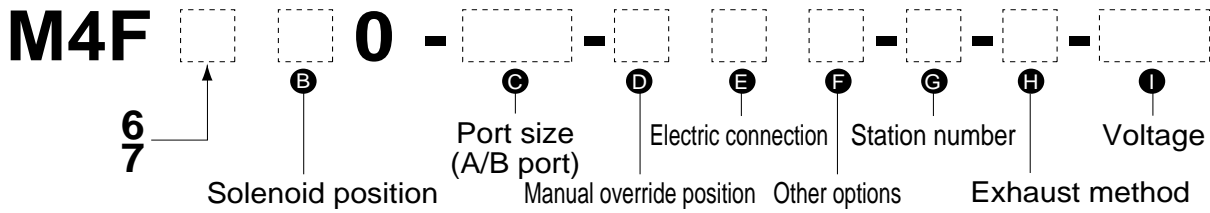
● Manifold model no.

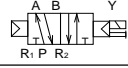

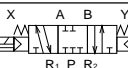
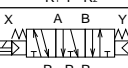
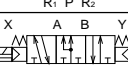
Solenoid valve			Installation position										Sub-total	Total	
JIS symbol	Model	Port size	1	2	3	4	5	6	7	8	9	10			
2-position single solenoid 	4F6	Rc 1/2													
	4F7	Rc 3/4													
2-position double solenoid 	4F6	Rc 1/2													
	4F7	Rc 3/4													
3-position all ports closed 	4F6	Rc 1/2													
	4F7	Rc 3/4													
3-position A/B/R connection 	4F6	Rc 1/2													
	4F7	Rc 3/4													
3-position P/A/B connection 	4F6	Rc 1/2													
	4F7	Rc 3/4													
Masking plate															
Partition plate	P port circuit														
	R <sub>1</sub> port circuit														
	R <sub>2</sub> port circuit														
3 way valve specifications	N.C. (C1: Plug to A)														
	N.O. (C2: Plug to B)														

- MN3E0
- MN4E0
- 4GA/B
- M4GA/B
- MN4GA/B
- 4GA/B (Master)
- W4GA/B2
- W4GB4
- MN3S0
- MN4S0
- 4TB
- 4L2-4/LMF0
- 4SA/B0
- 4SA/B1
- 4KA/B
- 4F
- PV5G/CMF
- PV5/CMF
- 3MA/B0
- 3PA/B
- P/M/B
- NP/NAP/NVP
- 4F\*0E
- HMV
- HSV
- 2QV
- 3QV
- SKH
- PCD/FS/FD
- Ending

Individual wiring manifold  
5 port pilot operated valve