

AUTOMATIC AND PROCESS FILTERS

PRECISION THAT DOES NOT STOP

Long-lasting and efficient filtration solutions for applications in continuous operation



WITH OUR AUTOMATIC- AND PROCESS FILTERS WE ARE MAKING THE WORLD



safer

our fully automatic filter systems help to protect employees and the reliability of the operating systems



healthier

by using high-performance filter systems to ensure that food is free of foreign particles and that only completely purified process water can get into the environment



more productive

in that our automatic- and process filters enable an uninterrupted and resource-saving operation and protect systems against wear and damage in the long term

A CALCULATION WITHOUT HIDDEN COSTS



AUTOMATIC AND PROCESS FILTERS from Filtration Group achieve consistently high filtration results in continuous operation over a long period of time. Therefore, they are predestined for use in industrial manufacturing processes, in power plants or in shipping. Since the automatic filters clean themselves during operation, they require no consumables, cause no process interruption and protect employees from contact with hazardous substances. They are also durable: the housing and filter elements are made of robust, corrosion-resistant materials.

In filtration technology, Filtration Group focuses on environmentally friendly processes that do not require chemical additives. This has a positive effect on the environmental balance of a company as well as the excellent filtration results, which are precisely matched to the respective process, the process liquid and the

required degree of purity. Cleanly filtered liquids can also be reused. The reduced need for cooling lubricants, washing media, cleaning liquids and process water is not only an ecological but also an economic gain.

In medium term, the high-performance filter systems also pay for themselves because they make an effective contribution to extending the service life of tools, pumps, systems and machines. The investment in automatic- and process filters from Filtration Group is foresighted and economical in every respect.

In the end, everyone benefits: the employees, the environment and the company. In this way we are fully living up to our credo:

WE INSPIRE OUR CUSTOMERS.

OUR HISTORY

As an expert in industrial filters of all kinds, the Filtration Group can look back on decades of intensive development work that went hand in hand with technical progress. A broad portfolio of filtration solutions emerged from innovative strength, experience and well-founded specialist knowledge, which meets almost every requirement. That is why the Filtration Group is one of the world's leading suppliers in the field of automatic and process filters.

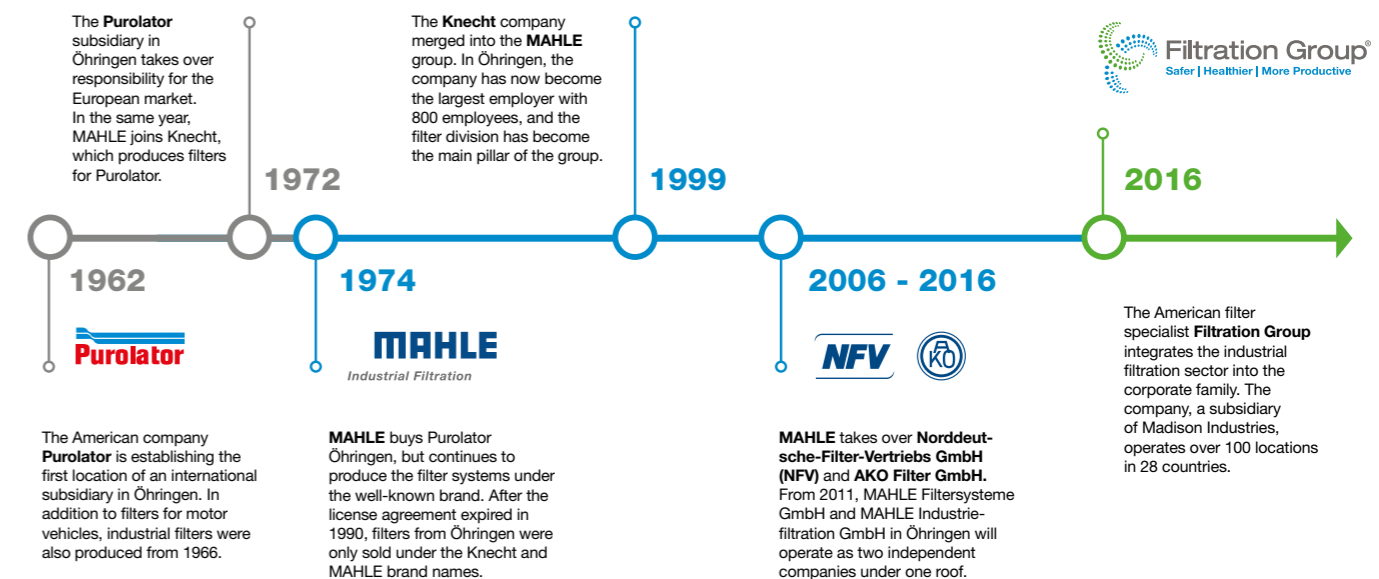

MARKET SEGMENTS / APPLICATIONS

BEST RESULTS COME AUTOMATICALLY

A broad product range, technical expertise from decades of experience and proven use in practice make automatic filter systems from Filtration Group the first choice in numerous application areas. The advantages come into play everywhere: Automatic Filters clean themselves, show outstanding efficiency in combination with innovative filter elements and technologies. Thanks to their robust design they are designed for durability.

WATER TREATMENT

For responsible use of a precious resource



THE ECONOMIC SUCCESS a company depends on resources. This includes responsible handling of process and waste water. Filtration Group has suitable filter solutions for cleaning water that is fed into the production process as process, cooling or extinguishing water and the wastewater that is to be drained into the sewage system, into coastal water or into groundwater. Here, the European Water Directive sets strict targets for the quality of the treated process water, which FG products reliably ensure compliance. The various back-flushing filters ensure stable and thus cost-efficient production processes as well as a positive environmental balance allowing a responsible use of this ecologically and economically valuable resource.



Back-flushing filter AF 8

CHEMICAL INDUSTRY
INDUSTRIAL FOOD MANUFACTURING

For maximum efficiency under difficult conditions

In the chemical industry and in the industrial production and manufacturing of foods, strict environmental and safety regulations apply. Reliable, high-performance filtration creates the prerequisites for both standard-compliant and profitable production.



CHEMICAL INDUSTRY

FG metal edge filters clean raw materials such as isocyanate or polyol before they are fed into reaction casting machines or foaming systems and thus protect nozzles, mixing heads and coating machines from contamination. The efficient automatic filter systems are robustly built and clean themselves. In this way, the production process does not have to be stopped to change filters and employees do not come into contact with harmful substances.

SPECIFICALLY:

- Design for high temperatures (up to 400 degrees Celsius)
- Version for explosion protection zones and certification ATEX 2014/34 / EU
- Design according to PED, EN13445 and ASME
- Filtration of highly viscous media up to 200,000 mm²/s
- Separation and homogenization of gel-like particles

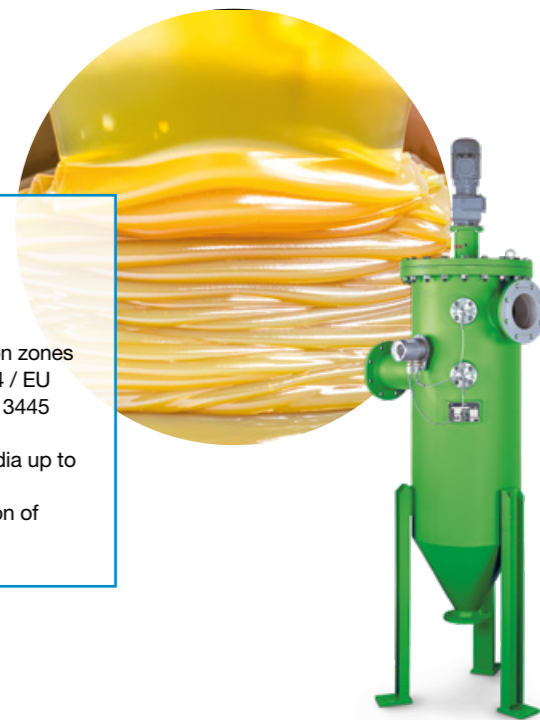

Back-flushing filter AF 74S

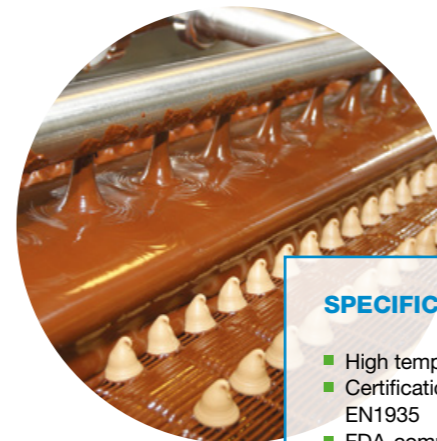

SPECIFICALLY:

- High temperature design
- Certification according to EN1935
- FDA-compliant plastic components



INDUSTRIAL FOOD MANUFACTURING

Automatic Filters from Filtration Group ensure that food is free of foreign particles. They also keep storage tanks and machine components clean. When filtering honey, chocolate or miscella, FG filter systems achieve excellent separation rates even at low temperatures. Even high heat does not limit the performance of the FG Automatic Filters: high-temperature versions of the filters separate breadcrumbs particles from the frying oil on large frying systems, for example. This way it can be used multiple times.



METALWORKING
INDUSTRIAL PARTS CLEANING
COOLING LUBRICANT TREATMENT

MARINE INDUSTRY AND INDUSTRIAL ENGINES

For full engine power in industry and on the high seas



WITH THE CLEAN FILTRATION OF LUBRICANTS AND FUELS, FG systems extend the maintenance intervals as well as the mileage and service life of large engines in industrial plants and ships. In addition, the efficient separation of pollutants favors the environmentally friendly operation of large engines.

The large product portfolio and the modular design of the filter systems ensure that there is a suitable filtration solution for every motor and every requirement.

FG fuel treatment systems reduce the proportion of residual water in the fuel to a minimum, thereby preventing, among other things, engine components from rusting. The degree of purity of lubricating oil also has a decisive influence on the performance and reliability of large engines. Oil maintenance systems filter solid and suspended particles, sediments, rust and water from the lubricants and thus protect the machine components sustainably.

SPECIFICALLY:

- Type approvals (e.g. DNV GL)
- High temperature design
- robust design
- High-quality corrosion protection systems for every application
- Long maintenance intervals without consumables
- On-ship service on request

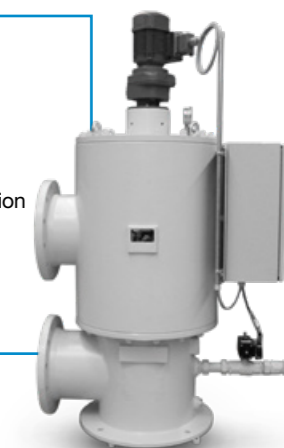

Back-flushing filter
R8 40 II

For high product and production standards



METALWORKING

In the metalworking industry, clean cutting emulsions, grinding oils and cooling lubricants ensure a smooth production process, they minimize the wear and tear of expensive precision machines and make a decisive contribution to the surface quality of the manufactured products. With complete systems and filter modules, Filtration Group provides adequate solutions for every area of application - from robust basket filters for separating coarse impurities to back-flushing filters for the fine filtration of cooling lubricants in machining processes with internal coolant supply.

INDUSTRIAL PARTS CLEANING

In industrial parts cleaning, FG filters and filter media ensure compliance with the precisely defined residual dirt and residual particle values for the workpieces by efficiently cleaning the process fluids. At the same time, this protects the expensive systems from contamination, ensures long-term availability of the cleaning media and makes an important contribution to operational safety and environmental protection.

COOLING LUBRICANT TREATMENT

While basket filters prevent coarse contamination, automatic filters also separate small particles from the cooling lubricants. When used in end washers or deburring systems, they achieve excellent cleaning results. The portfolio of tried and tested products is complemented by bag filters and candle filter elements for sophisticated fine filtration.



Back-flushing filter
AF 113G



METAL EDGE FILTERS

THE ROBUST SCRAPER WHEN THINGS GET TOUGH

HONEY, PASTE OR GEL-LIKE SUBSTANCES:

Wherever highly viscous liquids or pastes are used in the production process, the FG metal edge filter is choice to cleanly separate unwanted particles. Its robust construction with filter elements made of triangular stainless steel wire predestines this automatic filter for use in applications with high particle concentrations and volume flows up to 900 m³/h. The particle discharge can be regulated individually. With available gap widths between 30 and 2,000 µm, the Filtration Group range covers a wide range of applications. In addition to the preparation and homogenization of highly viscous liquids and pastes, FG metal edge filters have also proven their worth in the filtration of process water that is contaminated with coarse particles. Both in the variant with cast housing and in the welded version, the metal edge filter can even withstand high operating pressures.

FG metal edge filters can be specifically adapted to the requirements of each application scenario.

SPECIFICALLY:

Additional options:

- Integrated pre-separator for coarse particles and foreign particles
- Specific inlet and outlet connections
- Additional jacket for heating steam or liquid
- Shaft seal (for use on ships)
- FG service technicians support you on land and even at the high seas
- Certification from well-known ship classification companies such as Germanischer Lloyd
- For explosion protection zones as versions with the ATEX 2014/34 / EU certification

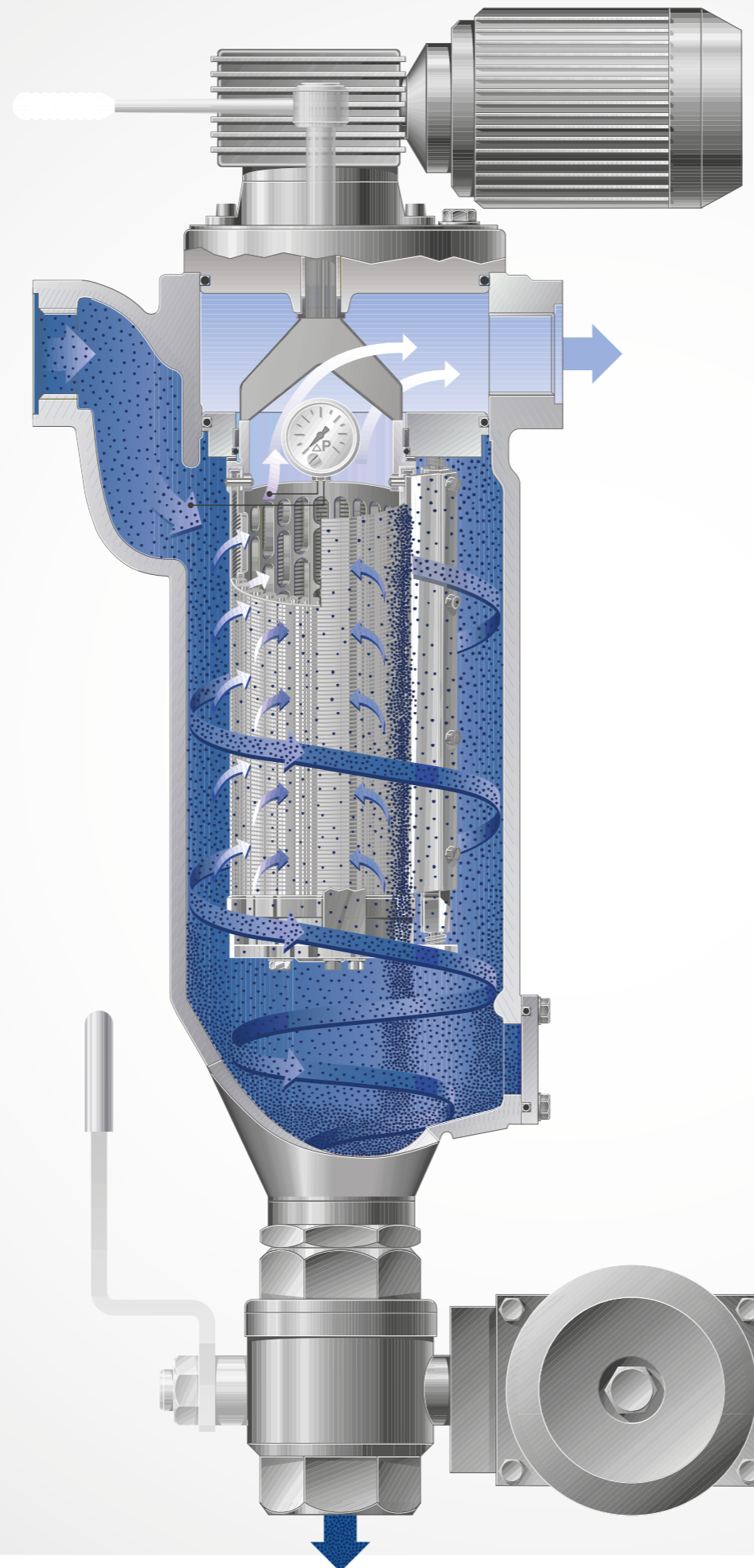

OPERATION PRINCIPLE:

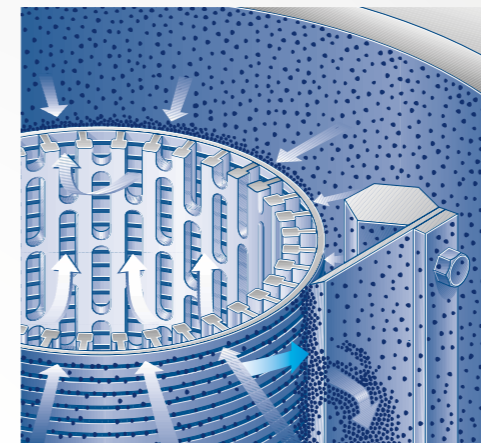

The substance to be filtered flows through the filter evenly from the outside in. Particles or foreign matter collect on the outside of the continuously rotating filter element. They are lifted from the surface with a spring-mounted scraper and sink into a collector cone, which is emptied via a drain valve.

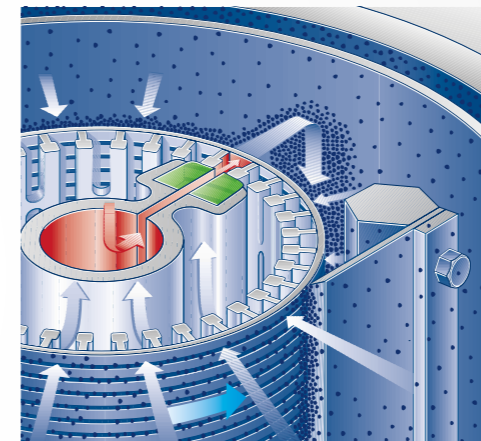

The AF 15x model combines the mode of operation of the metal edge filter with that of a back-flushing filter and thus increases the separation performance. On a segment on the inside of the filter, an external pressure medium also loosens stubborn foreign particles that have accumulated on the outside of the filter element. The medium is washed back, the particles are stripped off.



Back-flushing filter AF 72

Back-flushing filter AF 73

Back-flushing filter AF 71

BACK-FLUSHING FILTERS

THE RELIABLE CLEANER

FULL FILTRATION PERFORMANCE WITH SIMULTANEOUS CLEANING The central function of the FG back-flushing filter is its strongest selling point. Because where he does his job, nothing can stop him. The self-cleaning function, which is controlled either by the system's internal pressure or by an external pressure medium, enables permanent use in various areas of application. Its stable construction made of high-quality materials that hardly wear out guarantees a long service life and low maintenance costs and makes the filter insensitive to coarse and foreign particles. Thanks to the modular design, the filter adapts to any special conditions.

With their function and design, back-flushing filters from Filtration Group are suitable for fine and police filtration of cooling lubricants as well as fine filtration for protecting high-pressure internal coolant supply of machine tools. They have also proven their worth in process and wastewater treatment and in the separation of soft and gel-like particles, for example in the chemical industry or in industrial food processing. In special versions, they also demonstrate their qualities in special applications of all kinds. Additional options include, for example, a combination with an metal edge scraper, an integrated pre-separation or with a certification for Ex-protection zones 1 and 2.

SPECIFICALLY:

- Very low back-flushing volume
- High back-flushing efficiency due to segment cleaning
- Cleaning possible without interrupting the filtrate flow
- Large volume flows up to 7,000 m³/h
- Filtration fineness from 10 - 3,000 µm
- Type approvals (for example DNV GL) according to DRGL, AMSE, China Stamp and others
- Optional pleated or smooth-covered filter media

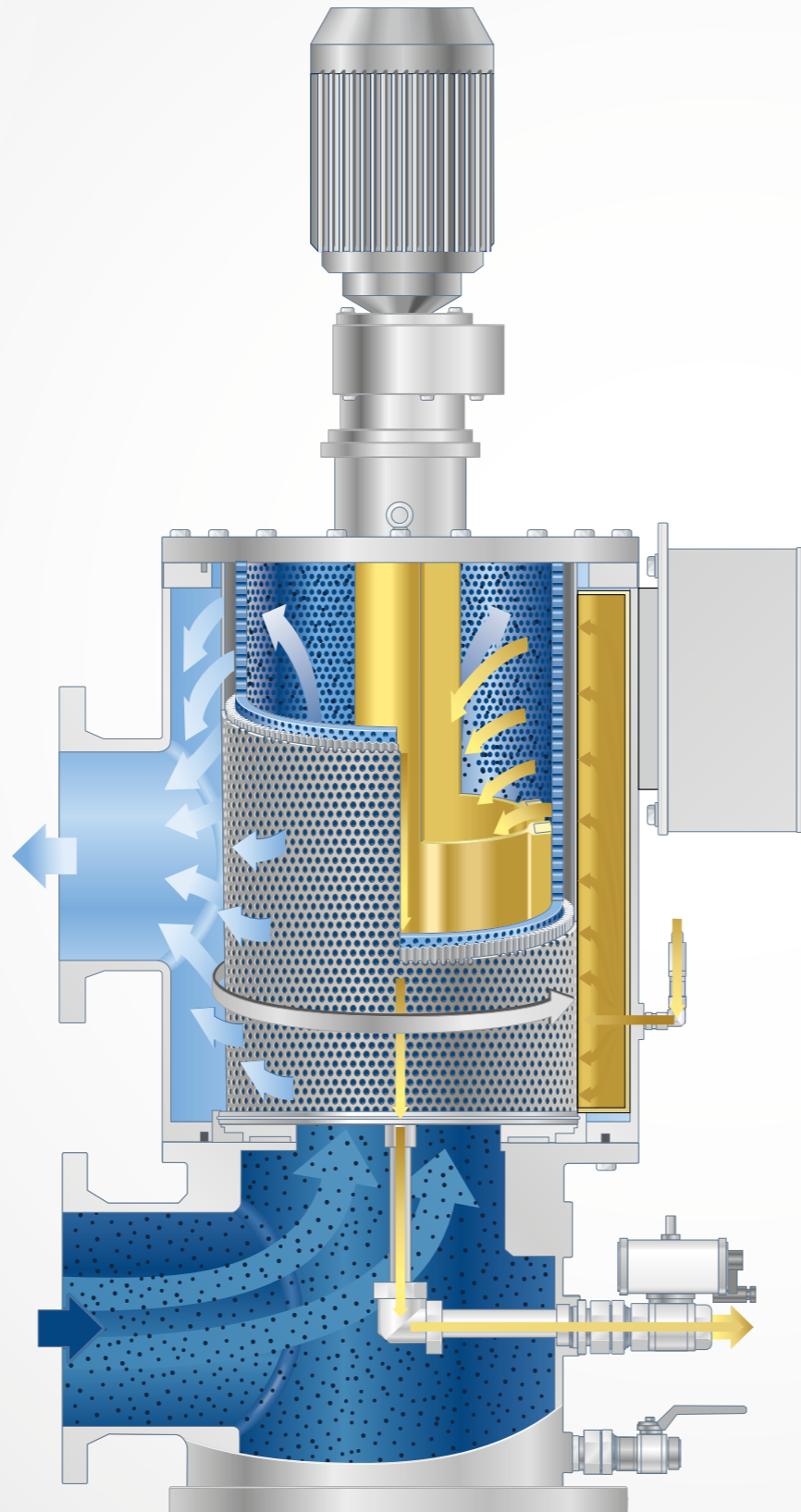

THE ADAPTABLE

Different cleaning principles depending on the application

SEGMENT CLEANING WITH INTERNAL PRESSURE

By rotating the filter element, the rinsing nozzle removes foreign matter and dirt particles in segments. Back-flushing nozzle with the filtrate is triggered by an operating pressure on the outlet side.

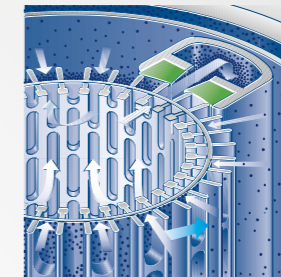

SEGMENT CLEANING WITH EXTERNAL PRESSURE

In this version, an external pressure medium triggers the back-flushing. Here too, the filter insert is cleaned of dirt and foreign particles segment by segment by rotating it 400 degrees around the flushing nozzle.

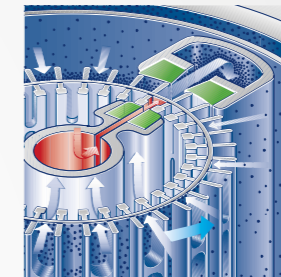

SEGMENT CLEANING WITH EXTERNAL PRESSURE AND PRE-SEPARATION

An external pressure medium triggers the back-flushing, with which stubborn particles are released from the filter element. Coarse particles are cleaned with the pre-separator and are removed from the collector cone via a drain valve.

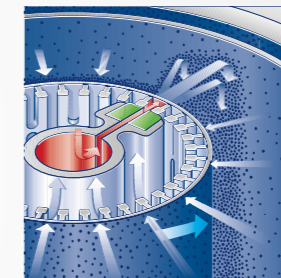

Back-flushing filter AF 173 G

THE UNIVERSAL

Efficient cleaning with minimal footprint

The substance to be filtered flows into the filter element from below through the inlet connection. It flows through from the inside to the outside, the dirt particles or collect on the inside of the filter media. The cleaned medium flows out through the outlet connection. With increasing pollution, the differential pressure between the inlet and outlet increases.

When it reaches a certain value, which depends on the filter fineness and the medium to be filtered, the flush valve opens. At the same time, the built-in motor allows the filter element or the back-flushing nozzle to rotate, depending on the design of the filter. The pressure difference between the filter outlet and the flushing line triggers a suction effect. As a result, a small amount of the cleaned medium flows back through the filter media and removes dirt particles. These are carried out with the back-flushing liquid. Since only the segment to which the back-flushing nozzle is directed is cleaned, the remaining part of the filter is still available for filtration.

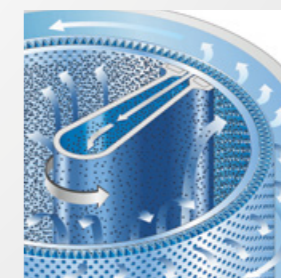
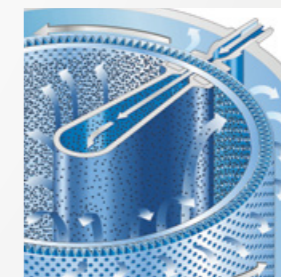

Back-flushing filter AF 8



FILTERS CARTRIDGES

THE BEST CHOICE FOR HIGH-END FILTRATION

THE INNOVATIVE MATERIAL STRUCTURE AND SPECIAL DESIGN predestine FG high-end filter cartridges for the filtration of alkaline, neutral and acidic washing media used in industrial parts cleaning. The fact that they absorb significantly more dirt than conventional filters is primarily due to the unique structure of multi-layer glass fiber elements that are arranged in a pleated star around the cylindrical filter insert. A support fabric, which is shrunk onto the pleated filter medium, ensures stability and enormous pressure resistance. The glass fiber fabric becomes finer from the outside in. This also has a positive effect on the dirt holding

capacity. In addition, glass fiber is more thermally and chemically resistant than plastic. The filter retention rate is defined according to ISO 16889.

FG high-end filter cartridges combine several advantages in a single product: They ensure constant cleanliness of the washing media over the entire operating time, absorb a lot of dirt and keep the defined filter performance at a consistently high level until the end. Since they also have a long service life, FG high-end filters impress with an excellent price-performance ratio.

STRAINER

SIMPLE AND YET VERSATILE

IN MANY AREAS OF APPLICATION in industry and shipping, FG strainers are the best choice for reliably treating cooling liquids. The filter element is made of metal and can be easily cleaned with a high-pressure cleaner. FG strainers are available in many different versions as simplex filters or, for use without interruption, as duplex filters. Their robust design makes them insensitive to pressure fluctuations. They achieve a differential pressure resistance of up to 5 bar.

The liquid to be filtered flows through the strainer filter element from the inside to the outside. Dirt particles and foreign particles collect on the inside of the filter element. If a certain degree of contamination is reached, the filter insert for the simple variant is removed and cleaned. Unlike here, the duplex filter does not have to be stopped because the second filter does the work. The employee simply pulls a lever and can then remove the dirty filter for cleaning.



Strainer ES 46

Strainer EG 3



Strainer UG 54 TNG

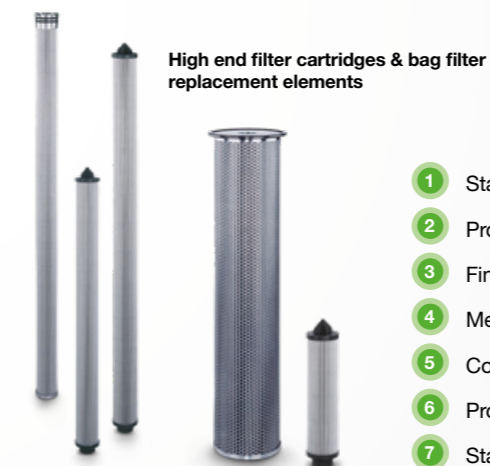

High end filter cartridges & bag filter replacement elements

- 1 Stainless steel supporting media
- 2 Protection fleece
- 3 Fine fiberglass media
- 4 Medium fiberglass media
- 5 Coarse fiberglass media
- 6 Protection fleece
- 7 Stainless steel supporting media



Filter housings

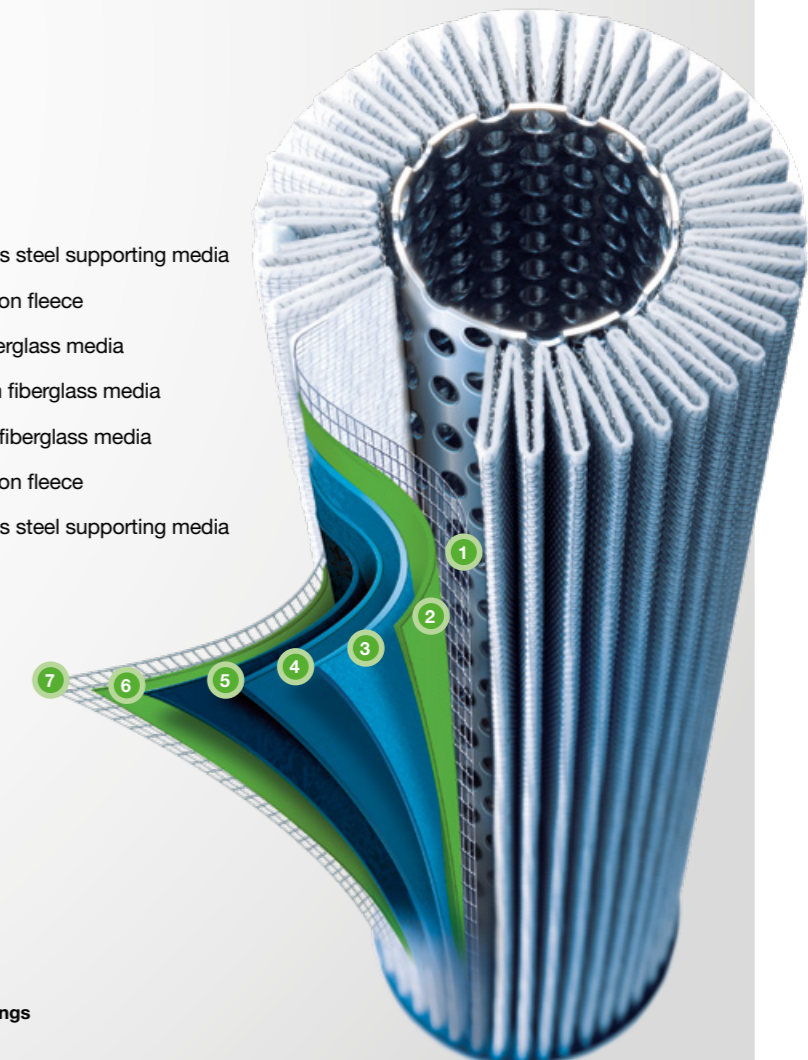

EVERYTHING FROM A SINGLE SOURCE

INCLUDED IN DELIVERY: OUR DRIVE TO INSPIRE YOU



APPLICATION MANAGEMENT

With us you are well advised

Our consulting and engineering service ensures that a filter system is installed at your site that corresponds exactly with the requirements of the relevant application. After analyzing the problem and determining the design parameters, we give a recommendation for the optimal system solution. Our experts take over project management and engineering project support for you. In order to be absolutely certain that filter systems and elements fit, we would also be happy to provide you with a test filter so that the performance can be perfectly tailored to your needs.



SERVICE

We stay by your side

The Filtration Group service technicians support you worldwide with the installation and commissioning of the filter systems and separators. For use on the high seas, specially trained specialists who are very familiar with the requirements on ships come on board. The limitless service package includes maintenance, repairs, element changes and the modernization and retrofitting of the systems. Of course, we also process complaints ourselves and are available to help and optimize your filter systems.



TRAINING

We'll get you in shape

The correct handling of filter systems is an important prerequisite for the optimal functionality of a system. That's why someone who knows his way around should get to work. This can either be our professional service team or your own employees, who to train to become an expert for your filter systems.



LABORATORY

We deliver results

In our laboratory we analyze every mixture that you send us as a sample. Whether fuel, crude oil or bilge water: Our test results provide reliable key data that you can use to design your filter systems. Of course, we would also be happy to assist you in the selection of the appropriate filter systems and elements.

REFERENCES

GOOD SOLUTIONS

Perfectly fitting solution for PVC pastes

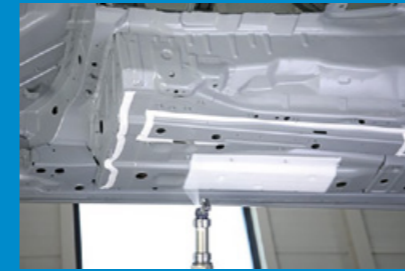

With its diverse properties, PVC is one of the most important plastics used in the automotive industry. As a material for underbody protection, for example, PVC platisole prevent a car from rusting downwards. In order for PVC to optimally protect the vehicle and at the same time to meet the high visual requirements of the paint shop, the filtration of the PVC media must be fine-tuned.

For the filtration and homogenization of highly viscous PVC pastes, the Filtration Group team initially supplied several test filters to define the correct filter rating. The decisive factor was that all harmful particles and

agglomerates were filtered out, but the relevant additives and protective components had to remain in the liquid PVC. The AF 71 H metal edge filter with a filter fineness of 250 µm delivered the best results for this specific application. The customer choose a manual variant in which the metallic filter element can be easily cleaned while the process is running. Compared to the previously used strainers, the FG metal edge filter proved to be a profitable investment. The customer saved the costs for the change of filters and the service provider for the filter cleaning. Even in the long run, the calculation works: thanks to the precisely set separation performance, the risk that deposited foreign substances restrict the process flow or even damage machines is reduced.

A guarantee of a pleasant working atmosphere

The use of cooling water systems is as diverse as the requirements for the appropriate filter. During the year, various foreign substances from the ambient air fly into the open or semi-open cooling towers, from which the cooling water must be cleaned before entering the heat exchanger. The nature and quantity of foreign particles, which differ regionally and depending on the season, represent a particular challenge. A powerful and resilient filter system is required for the reliable separation of the qualitatively and quantitatively fluctuating particle input.

For cooling water filtration in the air conditioning system of the Federal Chancellery, the Filtration Group team used with the R5-8 a fully automatic back-flushing filter with internal pressure cleaning. Its large filter surface and high back-flushing energy ensure reliable filtration even when the amount of particles is changing. It cleans 150 m³ of water per hour and only needs a comparatively small amount of flushing. This does not disturb the overall hydraulic system. Thanks to its compact design, the filter took up little space and could easily be installed in the air conditioning system. The FG back-flushing filter is now one of the most reliable and frugal employees - and helps to keep politicians and officials cool all year round.



WORLDWIDE AT OVER 100 LOCATIONS IN 28 COUNTRIES

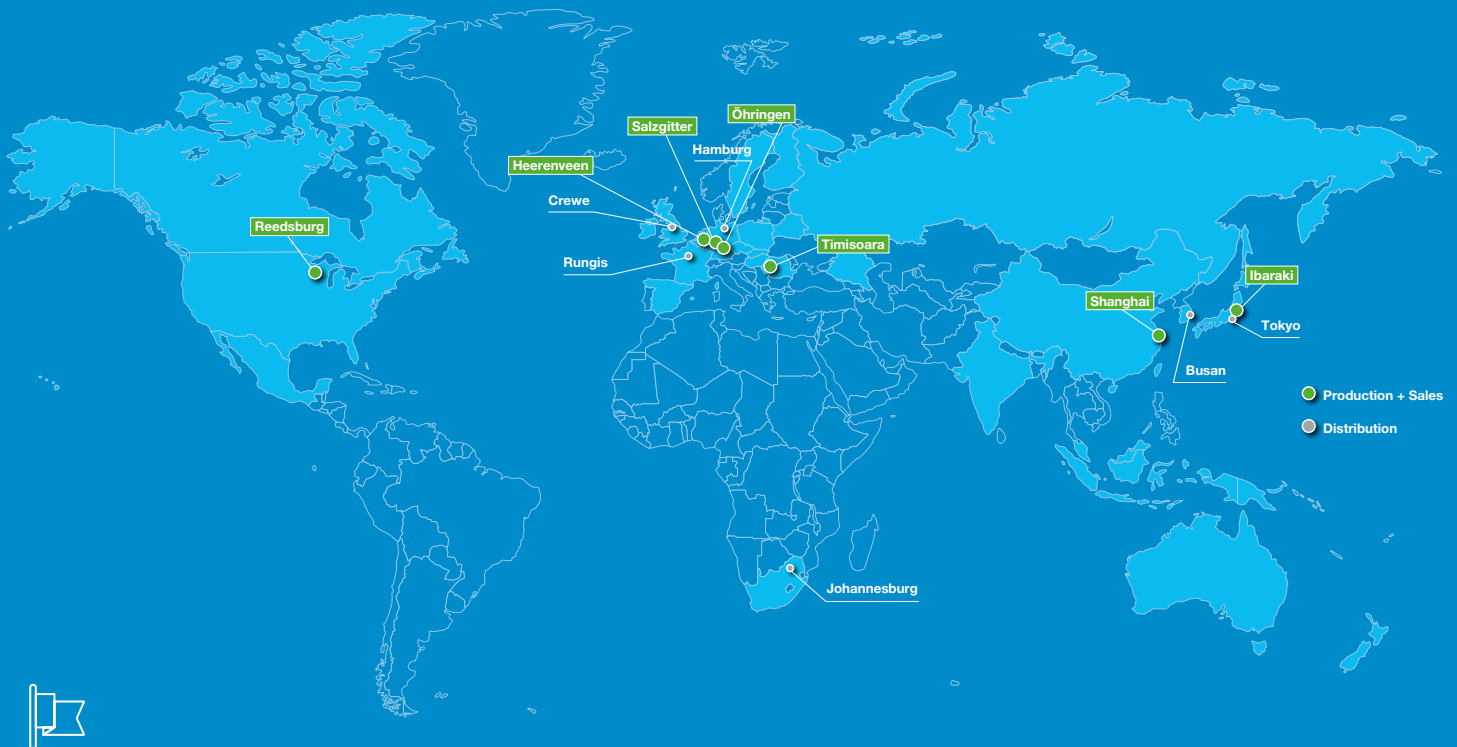

ADDRESSES

Filtration Group GmbH

Schleifbachweg 45
74613 Öhringen
Germany

Phone: +49 7941 / 6466 - 0
Fax: +49 7941 / 6466 - 429
Email: industrial@filtrationgroup.com

FG Industrial USA

2400 Zinga Drive
Reedsburg, Wisconsin 53959
USA

Phone: +1 608 / 524 - 4200
Fax: +1 608 / 524 - 4220
Email: industrial.usa@filtrationgroup.com

Filtration Group Japan Corporation

IS Yumicho Bldg, 1-28-24 Hongo
Bunkyo-ku
Tokyo 113-0033
Japan

Phone: +81 3 / 5802 - 7340
Fax: +81 3 / 5802 - 7345
Email: industrial.japan@filtrationgroup.com

Filtration Group (Shanghai) Co. Ltd.

B 501, Hangyi Road 8
Fengxian District
Shanghai 201401
China

Phone: +86 400 / 821 - 5175
Email: industrial.china@filtrationgroup.com

Filtration Group Srl.

Calea Stan Vidrighin 5A
Timisoara 300645
Romania

Phone: +40 256 / 408 - 230
Email: industrial.romania@filtrationgroup.com

Filtrair B.V.

De Werf 16
8447 GE Heerenveen
The Netherlands

Phone: +31 513 / 626 - 355
Email: marketing-filtrair@filtrationgroup.com

Filtration Group France

2 Place Gustave EIFEL IMMEUBLE DUBLIN
94563 Rungis
France

Phone: +33 1 / 45 12 05 30
Fax: +33 1 / 46 87 58 68
Email: industrial.france@filtrationgroup.com

Clear Edge Filtration CFE GmbH

Erzwäsche 44
D-38229 Salzgitter-Calbecht
Germany

Phone: +49 5341 / 8151 - 0
Fax: +49 5341 / 8151 - 52

Further information about our products and a local contact person from our worldwide partner network can be found on our website: industrial.filtrationgroup.com/locations

industrial.filtrationgroup.com